



Mach 1™ Valve Product Catalog

High Performance Plug Valve



Experience In Motion

Durco[®] Mach 1 High Performance Plug Valve

Flowserve has reinvented the non-lubricated plug valve to provide these new performance enhancing features:

- Lower, constant turning torques comparable to ball valves and significantly lower than other plug valves
- Higher temperature capability more comparable to gate and triple-offset butterfly valves (525°F / 274°C)*
- Easy seat replacement with valve in-line; no special tooling required
- ISO mounting pad
- ASME Class 150, 300 and 600 (derated) flanged butt weld, screwed end, socket weld, DIN 25-150
PN 10-16, 25-40, 100

*Excursions to 550°F (288°C) contact factory.

Double D Plug Stem
Accepts most standard actuation equipment.

In-Line Adjustment
Stops thru-line leakage.

ISO 5211 Mounting Pad
Universal flange for easy, low cost actuation. Optional flange flats.

Top Cap Tabs
Eliminates stress on fasteners during actuation.

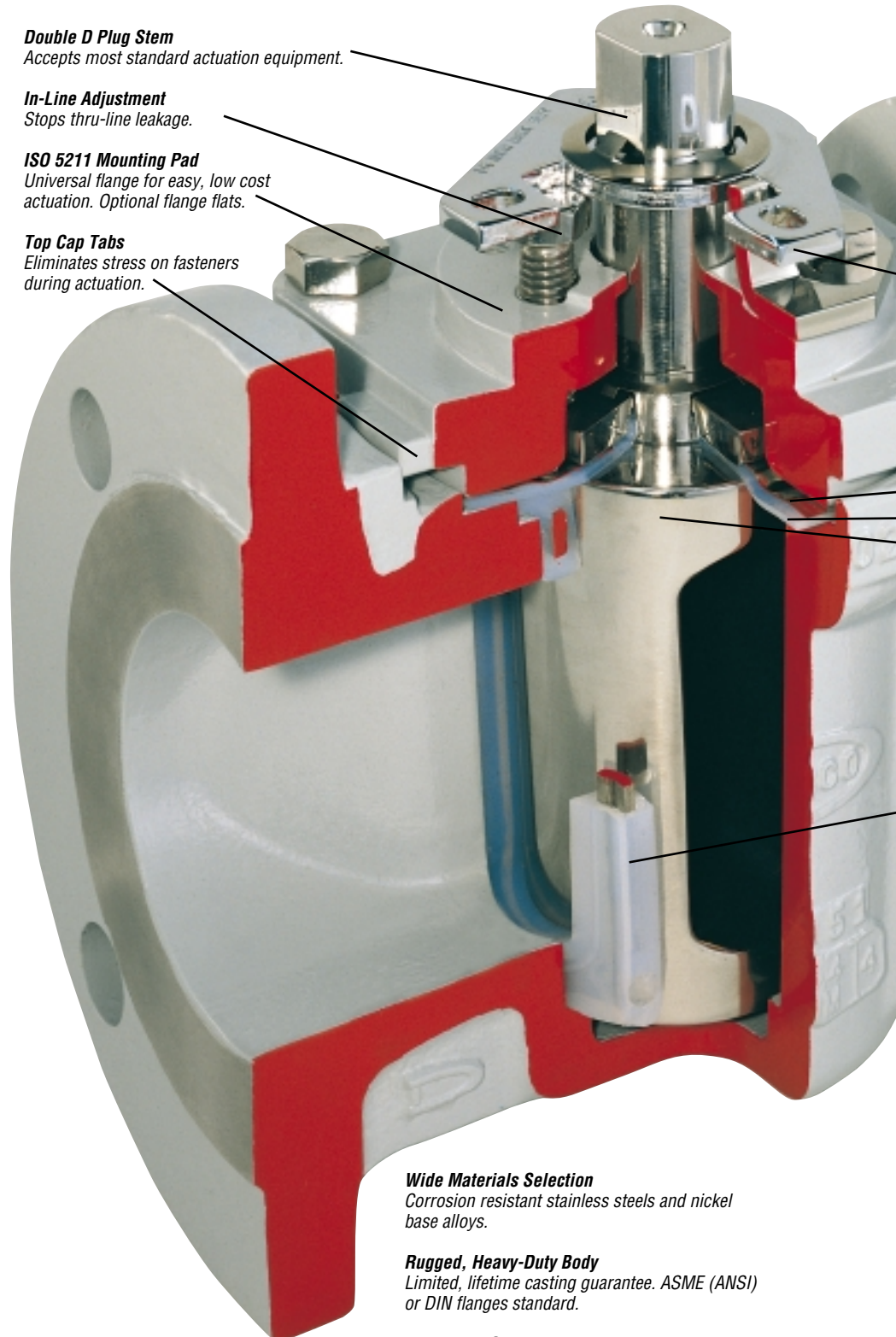

Wide Materials Selection
Corrosion resistant stainless steels and nickel base alloys.

Rugged, Heavy-Duty Body
Limited, lifetime casting guarantee. ASME (ANSI) or DIN flanges standard.

Firesealed Option
Fire tested in accordance with API 607, Fourth Edition.

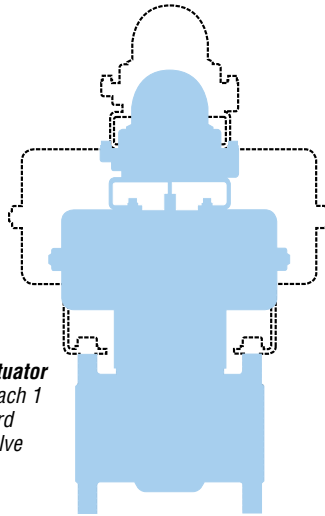

Required Actuator
 ■ New Mach 1
 --- Standard plug valve

Lockout
 Meets OSHA and plant safety requirements.

Metal Diaphragm
 Provides stem seal reinforcement.

PFA Reverse Lip Diaphragm
 Provides dynamic and static, self adjusting stem seal.

Tapered Plug
 Assures reduced turning torque and in-line seal adjustment for wear. Adjustment is independent of stem seals. With $\pm 3/16$ in (± 5 mm) adjustment, plug cannot bottom out.

Seats
 PFA with encapsulated alloy inserts standard for higher temperature and 360° sealing. Self-locking design. Easily removable for in-line replacement. Full sleeve option available.

Unique Port Seal Seats

The high alloy substrate extends the Mach 1's temperature range, reduces its turning torque and provides a 360° port seal.



U.S Patent



U.S Patent

Lower Torque

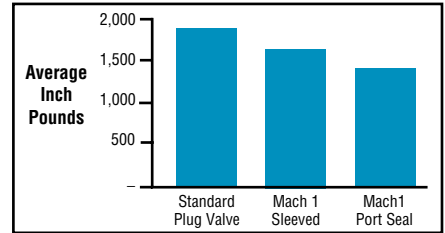

The average torque of the sleeve Mach 1 is 12% less than the standard plug valve, and the port seal on average is 25% less than the standard plug valve.

Higher Temperature

Mach 1 °F (°C)	Soft seat °F (°C)
600 (315)	600 (315)
575 (302)	575 (302)
550 (288)*	550 (288)
525 (274)	525 (274)
500 (260)	500 (260)
475 (246)	475 (246)
450 (232)	450 (232)
425 (218)	425 (218)
400 (204)	400 (204)
375 (190)	375 (190)

Maximum PTFE operating temperature

*Excursions to 550°F (288°C)

Higher Pressure

The Mach 1 is available in a Class 600 (derated) version. This provides more opportunities to satisfy customer and process requirements.

Easier Repair

Equipment needed for standard plug valve repair:

- Inner plunger
- Outer plunger
- Coining die
- Sizing plug
- Locking plug
- Plunger pin
- Arbor press
- Various hand tools

Equipment needed for Mach 1 valve repair:

- "C" Clamp (in-line)
- Arbor press (in-shop)
- Various hand tools

Mach 1 Marathon™

The Mach 1 Marathon is designed for reliable performance in high cycle on-off or modulating services. Fugitive emission containment is often equal to more expensive severe or toxic service valves.

Viton® O-rings

Full pressure containment stem seal. Also protects thrust collar from atmospheric corrosion. Kalrez® and other elastomers are available. PTFE backup rings help prevent extrusion of Viton O-rings under pressure.

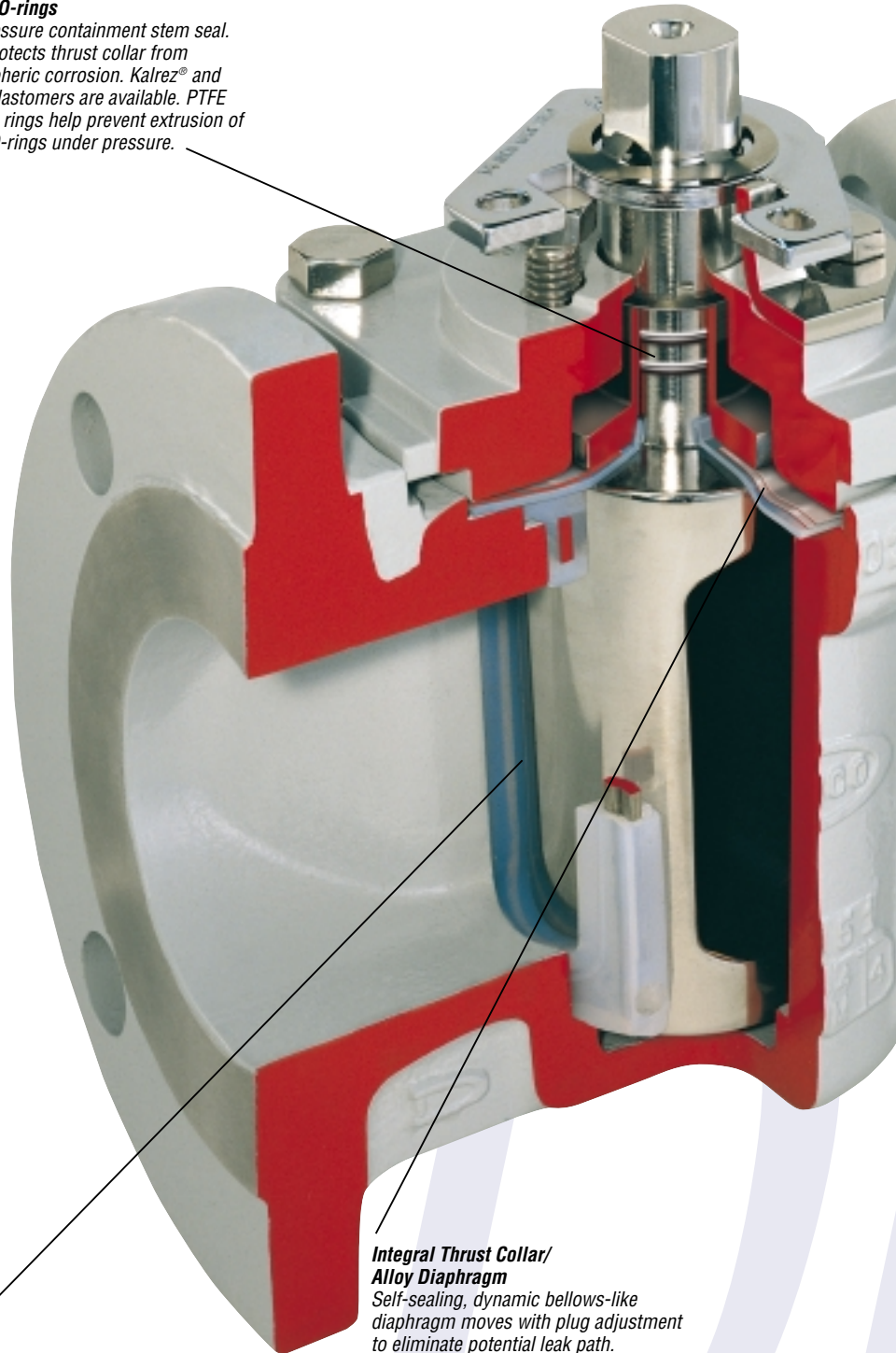

Smooth Sealing Surfaces

Highly polished surfaces eliminate wear and enhance seal integrity.

**Integral Thrust Collar/
Alloy Diaphragm**

Self-sealing, dynamic bellows-like diaphragm moves with plug adjustment to eliminate potential leak path. Hastelloy® (or optional materials) diaphragm welded to alloy thrust collar.

High Cycle Positive Stem Sealing Durability



Unique Stem-Sealing Design

The Marathon valve can be used with confidence in chemical processing applications where tight shutoff and emissions containment are priority requirements. As a bonus, its very design assures long-lived, high cycle performance.

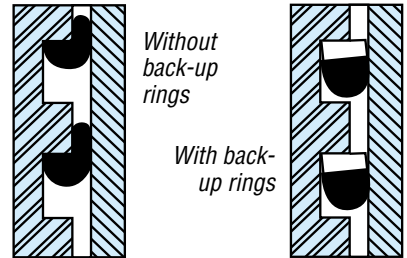

Viton O-Rings

A pair of Viton O-rings prevents stem leakage while containing line pressure. They also protect the thrust collar against attack from atmospheric corrosion. PTFE back-up rings firmly lock the Viton O-rings in the stem grooves and serve as anti-extrusion devices.

Optional Kalrez O-rings are available for special services.



New Welded Diaphragm

The integral thrust collar/alloy diaphragm is a third line of defense against leakage to the atmosphere. The underside of the metal bellows-like diaphragm acts as an expansion joint by allowing the PFA diaphragm to adjust to plug movement and pressure changes. The Hastelloy C diaphragm provides an impermeable barrier to chlorine as well as many other services.

Proven High Cyclability

Lab and field tests have proven that the Marathon can cycle as many as three-to-five times more than a standard PTFE sleeved quarter-turn valve before it begins to show stem seal wear.

Marathon Valve

Viton o-rings & welded metal diaphragm stem seals
Sleeve & Diaphragm cut in four places

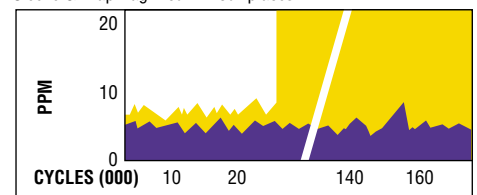

■ Conventional Plug Valve >2000 PPM
■ Marathon Valve

Passing The Test

Lab technicians defeated the PFA sleeve and PFA diaphragm, the primary and secondary stem seals, by cutting both of them in four places. They operated the valve to 160,000 cycles. Rather than using the standard Method 21 methane emissions test, they chose the more demanding helium emissions test. The results were impressive.

Durco Mach 1 Fire Sealed

Durco Mach 1 valves have been fire tested in accordance with API 607 Fourth Edition. They surpassed the external sealing requirements of Section 4, Paragraph 4.2, “Performance Requirements.” Durco valves also offer the process industries’ widest range of non-lubricated plug valve models, materials and configurations. This provides customers the flexibility to specify Mach 1 valves to meet virtually all their applications needs.

Mach 1 Fire Sealed valves incorporate special Grafoil® packing rings at the stem and Grafoil gaskets at the top cap. These reduce atmospheric leakage to a negligible amount should fire destroy the PFA sleeve and diaphragm. A metal diaphragm keeps the Grafoil packing in place if the top seal is destroyed.

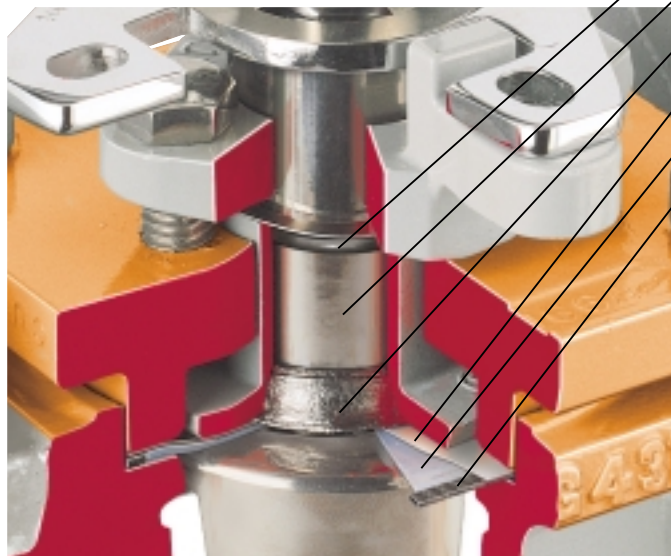

- O-ring
- Krytox Grease
- Graphite Packing
- Monel® Diaphragm
- PFA Diaphragm
- Grafoil® Gasket

Chlorine Valves

Designed especially for dry chlorine gas or liquid chlorine applications. All Durco Mach 1 chlorine valves are supplied with a vented plug. This vents the chlorine safely towards the high pressure side.

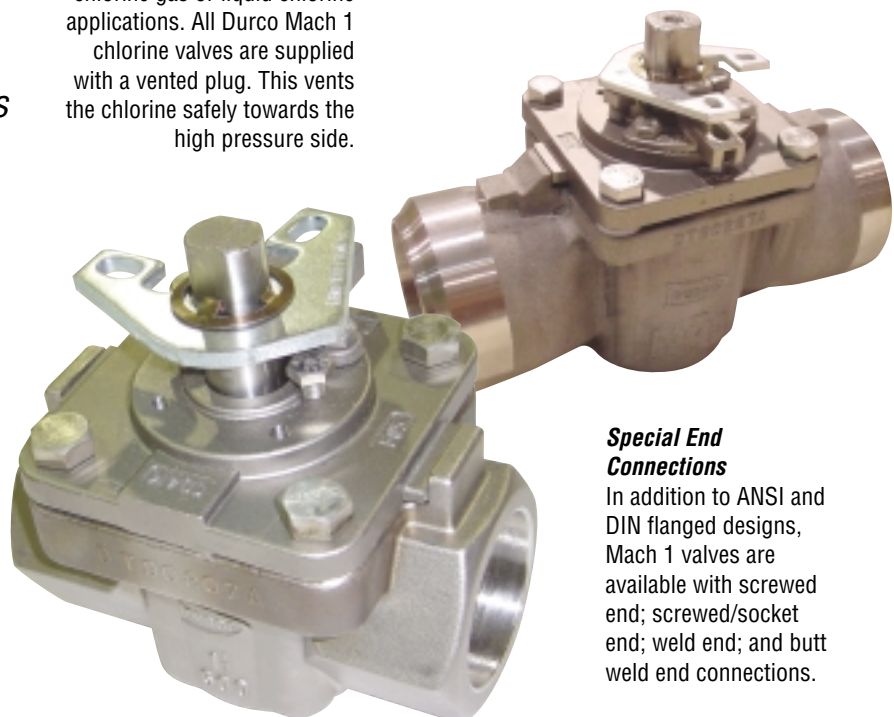

Special End Connections

In addition to ANSI and DIN flanged designs, Mach 1 valves are available with screwed end; screwed/socket end; weld end; and butt weld end connections.

Parts and Materials

Mach 1 Valve

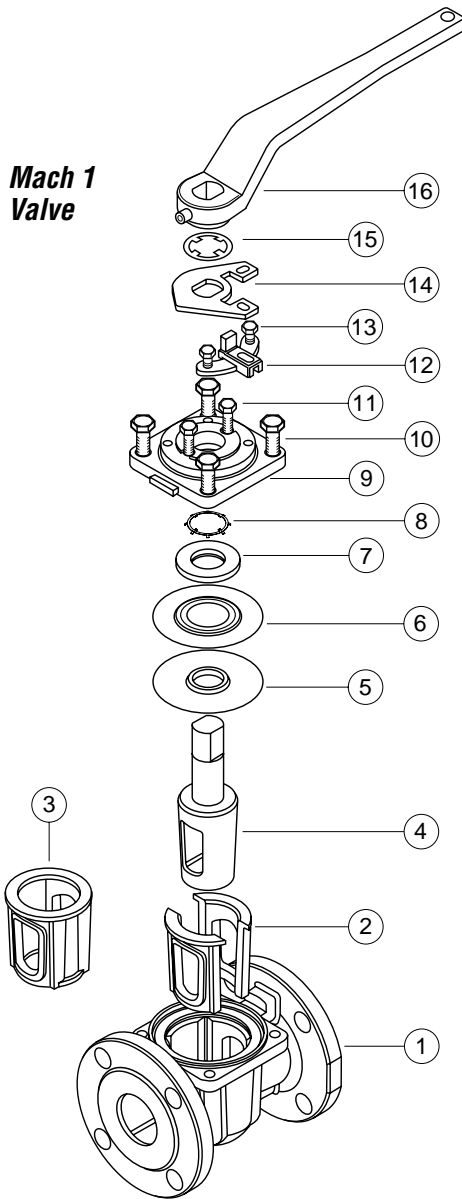

Mach 1 Parts and Materials			
Item No.	Description	Material of Construction	No. Req.
1	Body	Alloy or Ductile Cast Iron	1
2	Port Seal	PFA Encapsulated 316L SS	2
2•	Plug	*	1
3	Sleeve (Optional)	PFA Encapsulated 316L SS	1
4	Plug	Alloy	1
5	Diaphragm	PFA	1
6	Diaphragm	A666	1
7	Thrust Gland	304SS/17-4PH	1
8	Grounding Spring	302SS	1
9	Top Cap	CD4M, Ductile Cast Iron	1
10	Top Cap Fastener	Grade B9 Class 2B AISI (304SS) or B7	4
11	Adjusting Bolts	1840 Generic 300 Series Stainless Steel or B7	2
11•	Thrust Collar / Diaphragm	304/FER / Hastelloy®	1
12	Stop	CF8M	1
13	Stop Fastener	1840 Generic 300 Series Stainless Steel or B7	2
14	Stop Collar	Cadmium Plated Carbon Steel	1
15	Stop Collar Retainer	302 SS	1
16	Wrench	Ductile Cast Iron	1
17	Stem Packing	GA	1
18	Top Cap Gasket	GAWR	
19	Diaphragm	PFA	
20	Diaphragm	A666	
20•	Back-up Ring	PTFE	2
21•	O-ring	Viton (Kalrez optional)	2

Mach 1 Firesealed Exclusive Parts

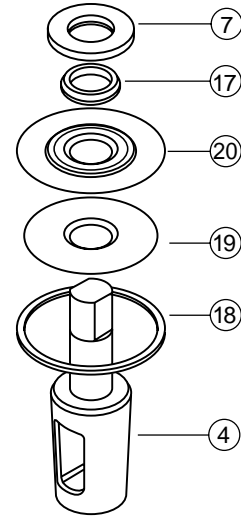

Mach 1 Marathon Exclusive Parts

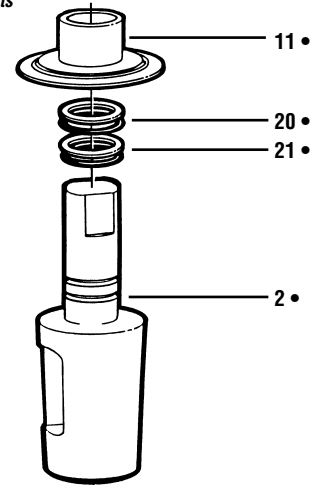

Applicable Valve Standards

Specification	Title
ASME B16.10	Face-to-face dimension
ASME B16.34	Steel valves, flanged
ASME B16.5	Flange & flange fitting
API 607	Fire safe valve testing
API 598	Valve inspection & test
M.S.S. SP-54	Radiographic
M.S.S. SP-55	Visual quality
M.S.S. SP-61	Hydrostatic testing

Materials Selection Chart A

DCI =	ASTM A395 Ductile Cast Iron
DS =	ASTM A216 Gr. WCB (Cast Steel)
D2L =	ASTM A351/A744 Gr. CF3 (304L S.S.)
D4 =	ASTM A351/A744 Gr. CF8M (316 S.S.)
DV =	Durcomet 5 (Durco's High Silicon Stainless Steel)
CD =	ASTM A351/A744 Gr. CD4M Cu (Durcomet 100)
D20 =	ASTM A351/A744 Gr. CN-7M (Durimet 20)
CK3M =	ASTM A351/A744 Gr. CK-3MCuN (254 SMO) ¹
DM1 =	ASTM A494 Gr. M35-1 (Monel 400) ²
DNI =	ASTM A494 Gr. CZ-100 (Nickel 200)
DC2 =	ASTM A494 Gr. N-7M (Chlorimet 2)
DC3 =	STM A494 Gr. CW-6M (Chlorimet 3)

1. Registered trademark of Avesta AB

2. Registered trademark of the International Nickel Company, Inc.

Actuation Options For Mach 1 Valves



Manual Operation

A hand wrench is standard for manual operation through 6 in (150 mm). Gearbox is required on 6 in (150 mm) valves with optional sleeve.

Actuation

Flowserve's Automax[®] operation is a specialist in valve automation systems offering rack and pinion, heavy-duty and electric actuators along with positioners, limit switches, engineered special control circuits and related accessories.

Control Valves

V-Port control valves are available in a variety of trim configurations to satisfy your exact flow control needs.

Unaffected by ΔP , the turning torques for Mach 1 plug valves are constant. Actuation costs are significantly reduced since the Mach 1 uses actuators that are one, two and even three sizes smaller than those used with other plug valves...and even smaller than some ball valves.

Flow Rates (Estimated)

Size in (mm)	C _v (K _v) Value
1 (25)	41 (35)
1-1/2 (40)	81 (70)
2 (50)	161 (139)
3 (80)	267 (230)
4 (100)	548 (472)
6 (150)	1001 (863)

C_v = US gal/min at 1 psi ΔP (K_v = m³/h at 1 bar ΔP)



Mach 1/Automax Package

Mach 1 valves feature automation sizing torques comparable to ball valves along with the bi-directional, adjustable and bubble-tight sealing performance of a plug valve.

Sizing Torques

Valve Size in (mm)	Standard Plug Valve	Mach 1 Sleeved	Mach 1 Port Seal
1 (25)	335	310	260
1-1/2 (40)	497	430	370
2 (50)	675	600	550
3 (80)	1180	1020	860
4 (100)	2400	2200	2000
6 (150)	6000	5200	4320

Because services vary greatly with regard to temperature, clean-clear or slurry conditions, please consult the factory for sizing torques – 931-432-4021.

Flow Characteristics

Typical characteristic curve for standard Mach 1 valve

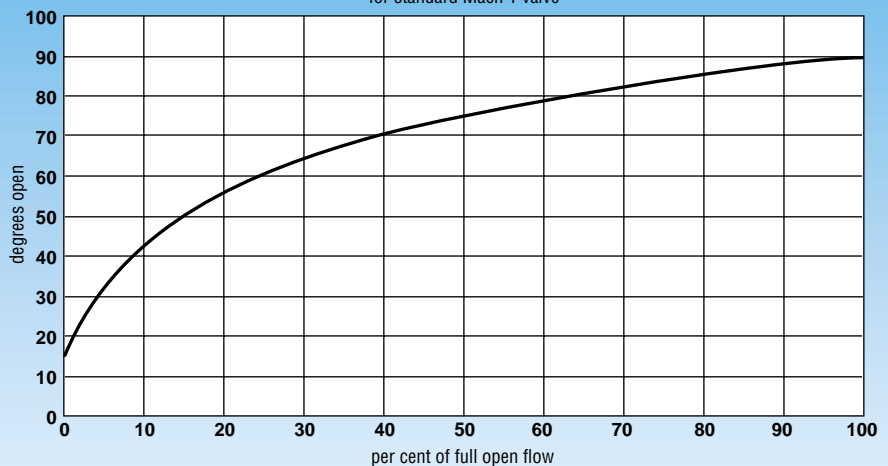

Mach 1 Straightway Valve Dimensions

1 in (25 mm) to 3 in (80 mm) Valves

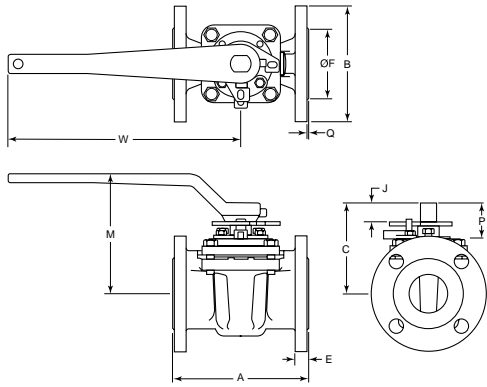

4 in (100 mm) and 6 in (150 mm) Valves

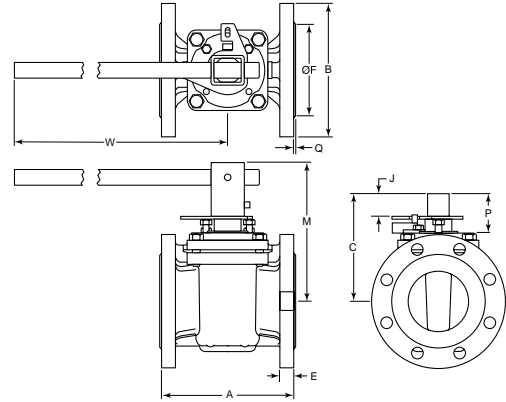

English Units																												
Valve Size	Drilling Class 150			Drilling Class 300			Drilling Class 600			A			B			C	E			F	J	M	P	Q			R	W
	No.	Size	BC	No.	Size	BC	No.	Size	BC	150	300	600	150	300	600		150	300	600					150	300	600		
1	4	0.63	3.13	4	0.75	3.50	4	0.75	3.50	5.00	6.50	8.50	4.25	4.88	4.88	3.49	0.44	0.69	0.94	2.00	0.62	4.65	1.50	0.06	0.06	0.25	1.38	7.00
1.50	4	0.63	3.88	4	0.88	4.50	4	0.88	4.50	6.50	7.50	9.50	5.00	6.13	6.13	3.93	0.56	0.81	1.13	2.88	0.75	4.96	1.56	0.06	0.06	0.25	1.38	9.00
2	4	0.75	4.75	8	0.75	5.00	8	0.75	5.00	7.00	8.50	11.50	6.00	6.50	6.50	4.74	0.63	0.88	1.25	3.63	1.00	6.24	1.88	0.06	0.06	0.25	2.17	12.00
3	4	0.75	6.00	8	0.88	6.63	8	0.88	6.63	8.00	11.13	14.00	7.50	8.25	8.25	5.21	0.75	1.13	1.50	5.00	1.00	6.71	1.89	0.06	0.06	0.25	2.17	20.00
4	8	0.75	7.50	8	0.88	7.88	8	1.00	8.50	9.00	12.00	17.00	9.00	10.00	10.75	7.18	0.94	1.25	1.75	6.19	1.50	9.31	2.60	0.06	0.06	0.25	2.76	29.88
6	8	0.88	9.50	12	0.88	10.58	12	1.13	11.50	10.50	15.88	22.00	11.00	12.50	14.00	8.44	1.00	1.44	2.13	8.50	1.47	10.60	2.59	0.06	0.06	0.25	3.34	46.00

Metric Units																											
Valve Size	Drilling Class PN 10-16			Drilling Class PN 25-40			A		B		C	E		F		J	M	P	Q		R	W					
	No.	Size	BC	No.	Size	BC	10-16	25-40	10-16	25-40		10-16	25-40	10-16	25-40				10-16	25-40			10-16	25-40			
25	4	13.9	84.9	4	13.9	84.9	160.0	160.0	115.1	115.1	88.7	19.4	19.4	68.1	68.1	15.8	118.1	36.2	1.6	1.6	35.0	177.8					
32	4	18.0	100.1	4	18.0	100.1	184.5	184.5	140.0	140.0	88.7	20.3	20.3	80.9	80.9	15.8	118.1	36.3	1.6	1.6	35.0	177.8					
40	4	18.0	110.0	4	18.0	110.0	199.9	199.9	150.1	150.1	99.8	19.8	19.8	88.1	88.1	19.0	126.0	39.5	1.6	1.6	35.0	228.6					
50	4	18.0	125.0	4	18.0	125.0	229.0	229.0	165.1	165.1	120.4	21.7	21.7	102.1	102.1	25.4	158.5	45.5	1.6	1.6	55.0	304.8					
65	4	18.0	145.0	4	18.0	145.0	290.0	290.0	184.9	184.9	132.3	23.6	23.6	123.0	123.0	25.4	170.4	48.1	1.6	1.6	55.0	508.0					
80	4	18.0	160.0	4	18.0	160.0	310.0	310.0	200.0	200.0	132.3	25.6	25.6	138.2	138.2	25.4	170.4	48.1	1.6	1.6	55.0	508.0					
100	8	18.0	180.1	8	22.0	190.0	350.0	350.0	219.9	235.0	182.3	21.8	25.8	158.0	162.0	38.1	236.5	65.9	1.6	6.4	70.0	759.0					
125	8	18.0	210.0	8	26.0	220.0	400.1	400.1	249.9	269.9	182.3	23.6	27.6	190.2	190.2	38.1	236.5	65.9	1.6	6.4	70.0	759.0					
150	8	22.0	240.0	8	26.0	249.9	480.1	480.1	285.5	300.0	214.13	27.0	29.8	212.0	218.0	37.3	269.2	65.9	1.6	6.4	84.8	1168.4					

All dimensions are approximate and for illustrative purposes only. For exact dimensions request certified dimensional prints.

ISO Mounting Pad and Stem Dimensions

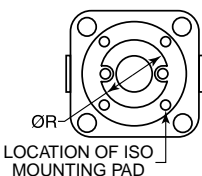
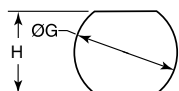

English Units						
Valve Size	ISO Mounting Pad				G	H
	No.	Size	BC	Hole Depth		
1	F05	M6	1.97	0.36	0.787/0.782	0.656/0.651
1.50	F05	M6	1.97	0.36	0.787/0.782	0.656/0.651
2	F07	M8	2.76	0.50	1.075/1.065	0.875/0.870
3	F07	M8	2.76	0.50	1.075/1.065	0.875/0.870
4	F10	M10	4.02	0.63	1.687/1.677	1.421/1.416
6	F12	M12	4.92	0.81	1.687/1.677	1.421/1.416

Metric Units						
Valve Size	ISO Mounting Pad				G	H
	No.	Size	BC	Hole Depth		
25	F05	M6	50.0	9.1	20.00/19.86	16.66/16.54
32	F05	M6	50.0	9.1	20.00/19.86	16.66/16.54
40	F05	M6	50.0	9.1	20.00/19.86	16.66/16.54
50	F07	M8	70.0	12.7	27.31/27.05	22.23/22.10
65	F07	M8	70.0	12.7	27.31/27.05	22.23/22.10
80	F07	M8	70.0	12.7	27.31/27.05	22.23/22.10
100	F10	M10	102.0	15.9	42.85/42.60	36.09/35.97
125	F10	M10	102.0	15.9	42.85/42.60	36.09/35.97
150	F12	M12	125.0	20.6	42.85/42.60	36.09/35.97

QV & QVB Weld End Valve Dimensions

Socket Weld and Threaded End Valves ASME B16.11

These valves can be welded without disassembly of the valve. Consult Flowserve Corporation for welding procedures and precautions. Welding of ductile iron is not recommended.

1/2 in (15 mm) thru 2 in (50 mm)
QV34 Class 150 & 300
 1/4 in (5 mm) - 3/4 in (20 mm)
 High Hub Wrench Standard

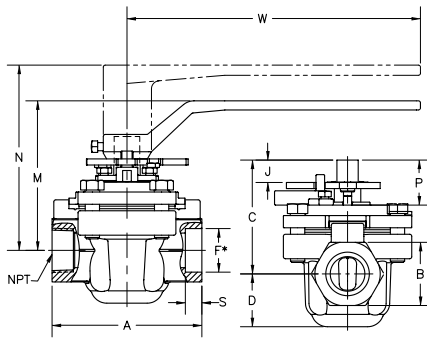

English Units

Valve Size	A	B	C	D	F*	J	M	N	P Class			S	W
									150	300	600		
0.25	4.59	1.94	3.49	1.62	0.56	0.62	4.65	5.68	1.53	1.53	1.49	0.38	9.00
0.38	4.59	1.94	3.49	1.62	0.70	0.62	4.65	5.68	1.53	1.53	1.49	0.38	9.00
0.50	4.59	1.94	3.49	1.62	0.86	0.62	4.65	5.68	1.53	1.53	1.49	0.38	9.00
0.75	4.59	1.94	3.49	1.62	1.07	0.62	4.65	5.68	1.53	1.53	1.49	0.51	9.00
1.00	4.59	1.94	3.49	1.62	1.34	0.62	4.65	5.68	1.53	1.53	1.49	0.51	9.00
1.50	5.50	2.56	3.93	1.92	1.92	0.75	4.96	5.99	1.65	1.65	1.63	0.51	9.00
2.00	6.00	3.13	4.74	2.24	2.41	1.00	6.24	6.43	1.94	1.94	1.87	0.63	12.00

Metric Units

Valve Size	A	B	C	D	F*	J	M	N	P Class			S	W
									150	300	600		
5	116.6	49.3	88.7	41.1	14.2	15.8	118.1	144.3	38.8	38.8	37.7	9.7	228.6
10	116.6	49.3	88.7	41.1	17.8	15.8	118.1	144.3	38.8	38.8	37.7	9.7	228.6
15	116.6	49.3	88.7	41.1	21.8	15.8	118.1	144.3	38.8	38.8	37.7	9.7	228.6
20	116.6	49.3	88.7	41.1	27.2	15.8	118.1	144.3	38.8	38.8	37.7	13.0	228.6
25	116.6	49.3	88.7	41.1	34.0	15.8	118.1	144.3	38.8	38.8	37.7	13.0	228.6
40	139.7	65.0	99.8	48.8	48.8	19.1	126.0	152.1	41.9	41.9	41.9	13.0	228.6
50	152.4	79.5	120.4	56.9	61.2	25.4	158.5	163.3	49.3	49.3	49.3	16.0	304.8

Note: Not available in ductile cast iron. Valves provided in D20, DC2, DC3, and DM will be furnished with stub ends pre-welded into valve.

Note: For ISO mounting pad and plug stem dimensions see page 9.

Butt Weld Valves

These valves can be welded without disassembly of the valve. Consult Flowserve Corporation for welding procedures and precautions. Welding of ductile iron is not recommended. 4 in (100 mm) through 6 in (150 mm) valves are normally gear operated. Butt-weld valves are machined to match schedule 40 (ASME) piping systems unless otherwise specified.

1/2 in (15 mm) thru 6 in (150 mm)
QV13 Class 150
QV33 Class 300

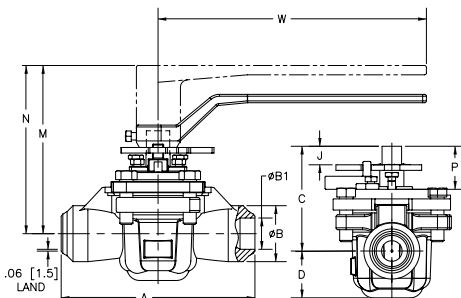

All dimensions are approximate and for illustration purposes only. For exact dimensions request certified dimensional prints.

English Units

Valve Size	A	ØB	ØB1	C	D	J	M	N	P Class		W
									150/300		
0.50	6.00	1.49	0.622	3.49	1.57	0.62	4.65	5.68	1.53		9.00
0.75	6.00	1.49	0.817	3.49	1.57	0.62	4.65	5.68	1.53		9.00
1.00	6.50	1.88	1.049	3.49	1.57	0.62	4.65	5.68	1.53		9.00
1.50	7.50	2.46	1.610	3.93	1.84	0.75	4.96	5.99	1.63		9.00
2.00	8.50	2.94	2.067	4.74	2.18	1.00	6.24	6.49	1.87		12.00
3.00	11.12	4.13	3.073	5.21	2.69	1.00	6.71	5.96	2.01		20.00
4.00	12.00	5.31	4.026	7.18	3.41	1.60	9.31	—	2.74		29.88
6.00	15.88	7.62	6.065	8.44	4.57	1.47	10.60	—	2.65		46.00

Metric Units

Valve Size	A	ØB	ØB1	C	D	J	M	N	P Class		W
									150/300		
15	152.4	37.8	15.80	88.6	39.9	15.8	118.1	144.3	38.8		228.6
20	152.4	37.8	20.75	88.6	39.9	15.8	118.1	144.3	38.8		228.6
25	152.4	37.8	25.64	88.6	39.9	15.8	118.1	144.3	38.8		228.6
40	190.5	62.5	40.89	99.8	46.7	19.1	126.0	152.1	41.4		228.6
50	215.9	74.7	52.50	120.4	55.4	25.4	158.5	164.8	47.4		304.8
80	282.4	104.9	78.05	132.3	68.3	25.4	170.4	176.8	51.1		508.0
100	305.0	134.9	102.26	182.4	86.6	40.6	236.5	—	69.6		759.0
150	403.4	193.5	154.05	214.4	116.1	37.3	269.2	—	67.3		1168.4

Note: Not available in ductile cast iron. Valves provided in D20, DC2, DC3, and DM will be furnished with stub ends pre-welded into valve.

Note: For ISO mounting pad and plug stem dimensions see page 9.

Testing and Pressure/Temperature Ratings

Mach 1 valves have been extensively tested to ensure the highest level of reliability possible.

The unique reverse lip stem seal has been tested from -50°F (-46°C) at 720 psi to 525°F (274°C) at 525 psi (36 bar).

High temperature throttling tests

at 525°F (274°C) with pressure drops of 175 psig (12 bar) have proven the superiority of Mach 1 valves over other soft-seated valves. Ask Flowserve Valve Sales Representatives for specific test results.

The valves have been temperature cycled to 525°F (274°C), and have

provided performance superior to any other soft-seated valve available for cyclical temperature situations.

We believe the Mach 1 valve is the best soft-seated valve on the market today, and will outlast and outperform all competitive valves.

Pressure-Temperature Ratings

The pressure-temperature ratings of the materials shown are based on mechanical property requirements cited in the latest ASTM or ASME specifications.

Valves may require adjustment to remain drop tight at the lower end of temperature range when operating below 0°F (-17°C) or during extreme temperature cycles.

How To Order

Size Family Class End Plug Style Alloy Plug Alloy Seats Operator Options

VALVE SIZE*		PRODUCT FAMILY		PRESSURE CLASS		END CONFIGURATION		PLUG STYLE		BODY ALLOY		PLUG ALLOY		SEATS		OPERATOR		OPTIONS	
Selection	Code	Selection	Code	Selection	Code	Selection	Code	Selection	Code	Selection	Code	Selection	Code	Selection	Code	Selection	Code	Selection	Code
1 in (25 mm)	1	2-way	QV	ASME Class 150	1	Raised Face Flange	1	2-way	C	D4	1	D20	2	PFA Port Seals	P	Wrench	0	Chlorine Cleaned	C
1.5 in (40 mm)	1.5	Marathon	QVB	ASME Class 300	3	Screwed End	2	Characterized	V	D20	2	D2L	8	PFA Sleeve	S	Gear	1	Oxygen Cleaned	O
2 in (50 mm)	2			ASME Class 600	6	Butt Weld	3			DM1	3	CD4M	0			Locking Gear	2	N.A.C.E. Trim	N
3 in (80 mm)	3			PN10	2	Socket Weld	4			DNI	4	DINC	N			Bare Stem	9	Fire Sealed	Z
4 in (100 mm)	4			PN16	4					DC2	5	CK3M	K			Actuated	K	Block and Bleed	B
6 in (150 mm)	6			PN25	7					DC3	6	DV	C						
				PN40	8					DS	8	DC1	D						
				PN100	9														

*Sizes 1-1/4 (32 mm), 2-1/2 (65 mm) and 5 in (125 mm) are DIN only. Code mm as size. Consult factory for more information.

Mach 1 Pressure/Temperature Ratings — Class 150, 300 and 600 Valves

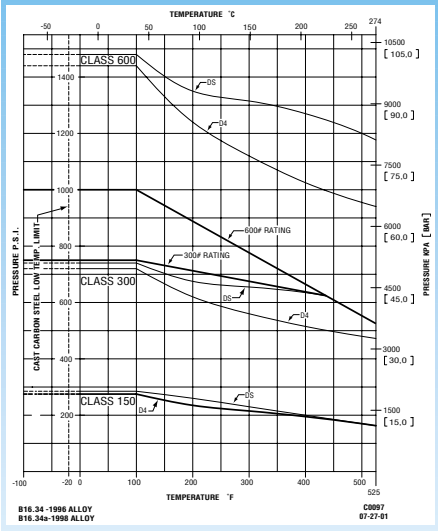

Selection, Installation, Operation and Maintenance

Although Flowserve can, and often does, provide general guidelines, it is obviously not possible to provide application specific data and warnings for all conceivable applications. The purchaser/end user must therefore assume the ultimate responsibility for the proper selection, installation, operation and maintenance of the products. Read the appropriate IOM available from Flowserve Corporation, Cookeville, TN 38501 before installing, operating or repairing any valve. The purchasers/end user should train its employees and/or contractors in the safe use of the Flowserve products in connection with the purchaser's manufacturing processes.

Design Changes

In order to follow Flowserve's commitment to continuous improvement, we reserve the right to change product and performance specifications without notice.



Flowserve Corporation
 Flow Control Division
 1978 Foreman Drive
 Cookeville, Tennessee 38501
 Phone: 931 432 4021
 Fax: 931 432 3105
 www.flowserve.com

Flowserve Ahaus GmbH
 Von Braun Straße 19a
 D-48683 Ahaus
 Germany
 Phone: +49 2561 686-0
 Fax: +49 2561 686-39

Flowserve Pte. Ltd.
 12 Tuas Avenue 20
 Republic of Singapore 638824
 Phone: 65 862 3332
 Fax: 65 862 2800

Bulletin FCD DVATB0030-01 (V-30e) (E) Printed in USA. July 2005.
 © Flowserve Corporation

To find your local Flowserve representative:

For more information about Flowserve Corporation,
 visit www.flowserve.com or call USA 1 800 225 6989



Flowserve Corporation has established industry leadership in the design and manufacture of its products. When properly selected, this Flowserve product is designed to perform its intended function safely during its useful life. However, the purchaser or user of Flowserve products should be aware that Flowserve products might be used in numerous applications under a wide variety of industrial service conditions. Although Flowserve can (and often does) provide general guidelines, it cannot provide specific data and warnings for all possible applications. The purchaser/user must therefore assume the ultimate responsibility for the proper sizing and selection, installation, operation, and maintenance of Flowserve products. The purchaser/user should read and understand the Installation and Maintenance (I & M) instructions included with the product, and train its employees and contractors in the safe use of Flowserve products in connection with the specific application.

While the information and specifications contained in this literature are believed to be accurate, they are supplied for informative purposes only and should not be considered certified or as a guarantee of satisfactory results by reliance thereon. Nothing contained herein is to be construed as a warranty or guarantee, express or implied, regarding any matter with respect to this product. Because Flowserve is continually improving and upgrading its product design, the specifications, dimensions and information contained herein are subject to change without notice. Should any question arise concerning these provisions, the purchaser/user should contact Flowserve Corporation at any one of its worldwide operations or offices.

©2005 Flowserve Corporation, Irving, Texas, USA. Flowserve and Durco are registered trademarks of Flowserve Corporation.