

Durco® G4 SleeveLine® Valves for HF Alkylation Service

Models G4BZ-HF Marathon™,
FRG4BCZ-HF and others



Durco G4BZ-HF Marathon valve— proven drop-tight shutoff

Flowserve has supplied thousands of Durco G4BZ-HF Marathon Sleeveless HF alkylation valves to refineries throughout the world. Engineered for high-cycle, low-emissions service, this non-lubricated plug valve offers an extra measure of positive stem sealing reliability. It can be used with confidence in applications where tight shutoff and emissions containment are unconditional requirements to ensure safety.

Durco G4BZ-HF Marathon valves are Phillips Licensing listed and UOP Process Division approved for the following applications:

- Isomerization
- Blending
- Light ends
- Gas plants
- Sulfur plants
- Crude desalting

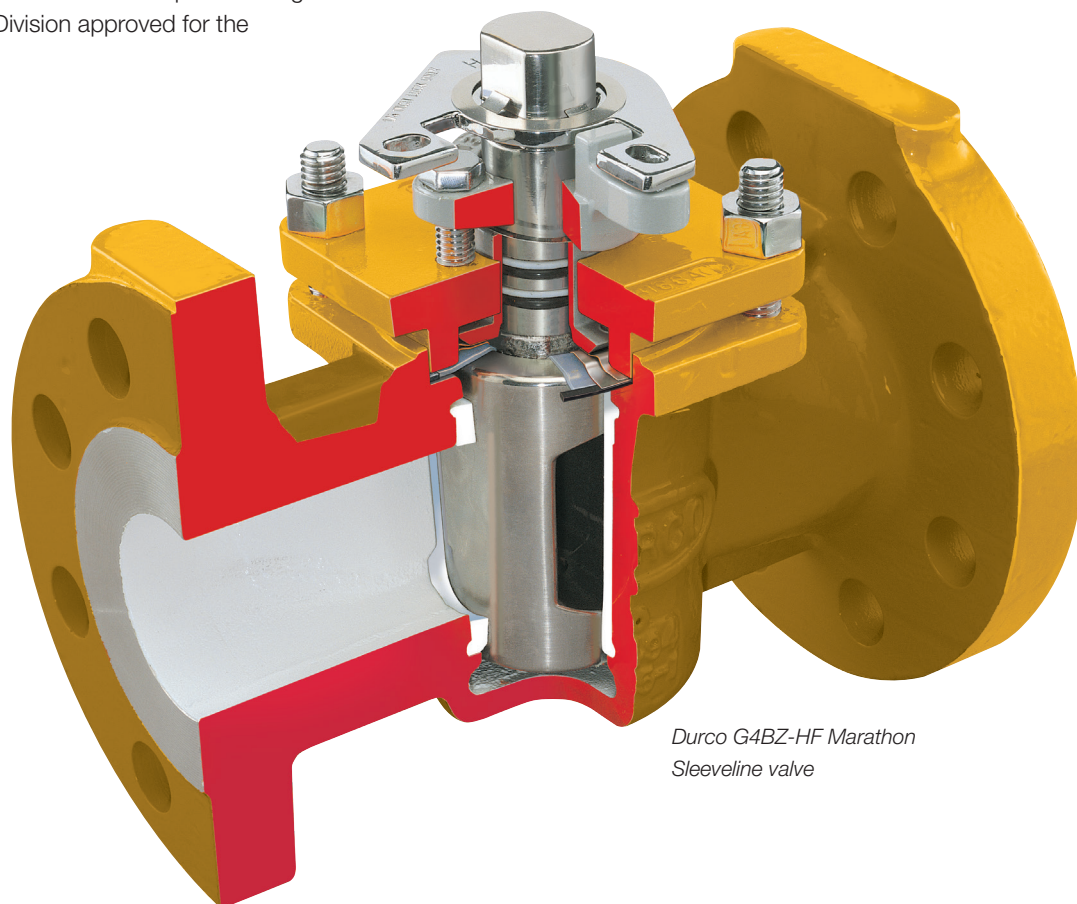

*Durco G4BZ-HF Marathon
Sleeveless valve*

Cost-effective, quarter-turn operation

Full open to full close in 90° turn, unlike multi-turn rising stem valves. May be cost-effectively operated with rotary actuators.

Non-lubricated design

No grease is required for valve operation or sealing. This eliminates the possibility of fouling flow meters and other instrumentation with lubricant.

Positive shutoff

PTFE sleeve (seats/seals) has a large sealing area for positive shutoff — 360° sealing at the top and bottom of the plug and around both ports. Grooves and ribs in the body prevent the sleeve from pistoning or rotating.

In-line adjustment

Rocker arm adjuster enables in-line adjustment of plug-sleeve. No need for seat relapping.

High-cycle positive stem sealing — guaranteed

The unique full-pressure stem sealing design of the Durco G4BZ-HF Marathon valve provides fugitive emissions containment that is often equal to more expensive severe or toxic services valves. In fact, it's guaranteed: if the G4BZ-HF Marathon stem seal fails within three years after installation, it will be repaired or replaced free of charge.⁽¹⁾

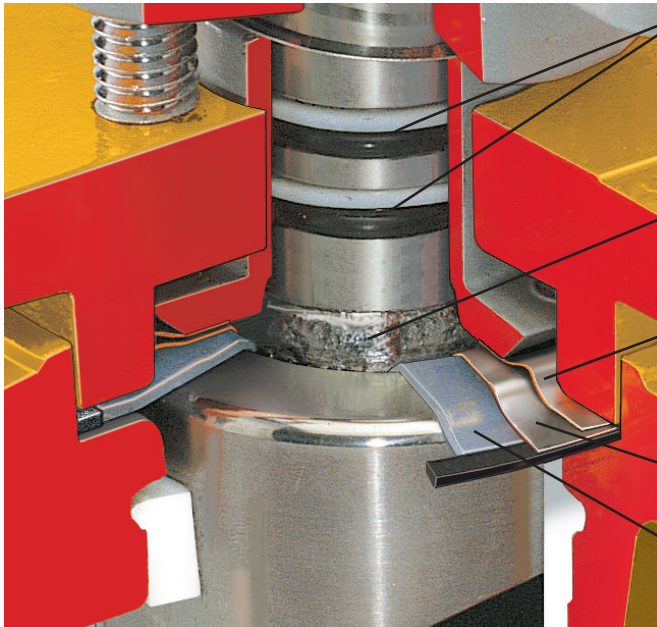

Viton® O-rings and PTFE backup rings prevent stem leakage while containing full line pressure. They also protect the thrust collar from atmospheric corrosion. Backup rings help prevent extrusion of O-rings under pressure. (Other elastomers are available.)

Grafoil® packing and gasket reduce atmospheric leakage to a negligible amount should fire destroy the PTFE sleeve and PFA diaphragm.

Dynamic integral thrust collar assembly is self-sealing and moves with the plug during adjustment to eliminate potential leak paths. Made from a Hastelloy® C-276 diaphragm welded to a CD4MCuN thrust collar.

Monel® secondary diaphragm keeps the Grafoil packing in place if the top seal is destroyed.

PFA diaphragm serves as a secondary external seal if any media passes beyond the plug and sleeve.

Long-lasting Monel construction

Solid M35-1 grade Monel body and plug ensure long valve life and unit operation. Plugs are highly polished to minimize wear and enhance seal integrity.

North American-sourced valve bodies with lifetime warranty

All valve bodies are sourced in North America and radiographed to ensure casting quality. U.S.-sourced valve bodies are available upon request. Body castings carry a lifetime replacement warranty in the event of a casting defect that results in through wall leakage when used within defined operating parameters.

Vented plug for safety

A vented plug reduces the possibility of pressure build-up under the plug caused by heating and expansion.

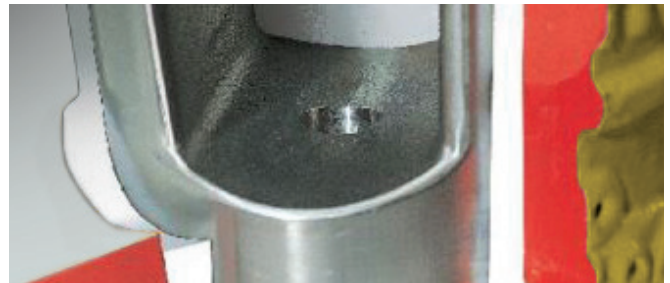

(1) Performance warranty applies, provided the valve is used in accordance with approved process information provided at time of order. Flowserve standard warranty terms and conditions apply. Failure to provide process conditions at time of order voids this performance warranty

Related configurations

Durco EG4Z-HF V-port control valves

Durco G4BZ-HF Marathon alkylation valves may be fitted with V-port plugs for precise modulating control services. They are available in a variety of trim configurations to satisfy your exact flow control needs.

- Specially trimmed EG4Z-HF V-port SoundTrim™ control valves reduce noise, cavitation and flashing while improving flow and pressure performance.
- Unique self-cleaning design prevents particulate build-up and clogging.

EG4Z-HF V-port C_v values

Size (in)	1	1	1	1	1.5	2	3	4	6
C _v	3.0	4.0	8.0	30	31	54	121	190	400



Durco FRG4BCZ-HF full round port valve

The full-port design of the Durco FRG4BCZ-HF valve makes it ideal for safety relief or pump isolation as well as RATS/RADS systems.

The FRG4BCZ-HF valve incorporates many proven features of the Durco G4BZ-HF valve, including the O-ring stem seal design, to ensure emissions protection. A new vertically loaded, radial fire-safe seal provides predictable compression and API 607-qualified performance for external leakage.

Available in sizes 1 to 8 in (25 to 200 mm).



Durco G4BZ-HFT Try-Cock valve⁽²⁾

This sampling valve consists of a ¾ in (20 mm) valve with screwed end connections. The plug utilizes a characterized or V-port with a C_v of 3.8. The valve is built and tested in accordance with the same specifications and procedures as our standard Durco G4BZ-HF Marathon SleeveLine alkylation valves.



*Durco G4BZ-HFT
Try-Cock valve*

End connections

In addition to ASME and DIN flanged designs, G4BZ-HF SleeveLine valves are available with screwed, screwed/socket and butt-weld end connections.

Special HF alkylation valves⁽²⁾

Upon request, Flowserve can provide special valves, such as three-way (transflow) mixing valves, relief valve isolation valves, and either fire-sealed BX 2001 high-performance or metal/graphite seated, fire-safe Durco TX3 triple-offset butterfly valves.



*Durco MG4BZ-HF
three-way valve*

Actuation⁽²⁾

Flowserve engineers can help select and size an automation system — including actuators, positioners, limit switches, engineered special control circuits and related accessories — to meet your specific application requirements



⁽²⁾ Not listed by Phillips or UOP

Technical data

Durco G4BZ-HF dimensions and flow rates⁽³⁾

Valve No.	End Connection	Size		Face-to-Face		Weight		C _v	
		in	mm	in	mm	lb	kg		
G4BZ32	300 lb screwed end	½	15	3½	89	3¼	1.7	7.4	
G4BZ32		¾	20	3½	89	3½	1.6	19.6	
G4BZ32		1	25	4¾	117	7	3.2	48.8	
G4BZ32		2	50	6	152	15¾	7.1	153	
G4BZ31	300 lb flanged end	½	15	5½	140	7¾	3.5	7.4	
G4BZ31		¾	20	6	152	10	4.5	19.6	
G4BZ31		1	25	6½	165	17¾	7.8	48.8	
G4BZ31		2	50	8½	216	29½	13	153	
G4BZ31		3	80	11½	283	69	31	322	
G4BZ31		4	100	12	305	164½	74	555	
G4BZ31		6	150	15½	403	231½	104	955	
G4BZ31		8	200	16½	419	328	148	1859	
G4BZ31		10	250	18	457	455	205	2361	
G4BZ31		12	300	19¾	502	736	331	3400 ⁽⁴⁾	
G4BZ31		14	350	30	762	916	412	3430 ⁽⁴⁾	
G4BZ31		16	400	33	838	2097	951	7000 ⁽⁴⁾	
G4BZ31		18	450	36	914	2183	990	7000 ⁽⁴⁾	
G4BZ31		20	500	39	990	2602	1180	7000 ⁽⁴⁾	
G4BZ35		300 lb screwed/ socket end	½	15	3½	89	3¼	1.7	7.4
G4BZ35			¾	20	3½	89	3½	1.6	19.6
G4BZ35	1		25	4¾	117	7	3.2	48.8	
G4BZ35	2		50	6	152	15¾	7.1	153	
G4BZ61	300 lb (600 lb flanges and face-to-face)	2	50	11½	292	39	18	153	

(3) For complete dimension information, refer to Durco bulletin DVENBR0024. (4) Calculated value

Durco FRG4BCZ-HF dimensions and flow rates

Valve No.	End Connection	Size		Face-to-Face		Weight ⁽⁵⁾		Port Area		C _v ⁽⁶⁾
		in	mm	in	mm	lb	kg	sq in	sq cm	
FRG4BCZ31	300 lb flanged end	1	25	6.5	165	22	10	0.8	5.1	76
FRG4BCZ31		1.5	40	7.5	191	41	19	1.8	11.4	202
FRG4BCZ31		2	50	8.5	216	67	30	3.1	20.3	392
FRG4BCZ31		3	80	11.13	283	157	71	7.1	45.6	986
FRG4BCZ31		4	100	12	305	231	105	12.6	81.1	2018
FRG4BCZ31		6	150	15.88	403	409	186	28.3	182.4	4750
FRG4BCZ31		8	200	19.75	502	947	430	50.3	324.3	9028

(5) Weights are bare stem valve.

(6) C_v are calculated based on CFD analysis.

Applicable standards

- ASME B16.10 — Face-to-face dimension
- ASME B16.34 — Steel valves, flanged and butt weld
- ASME B16.5 — Flange and flange fitting
- ASME B1.20.1 — Screwed ends
- API 607 — Fire-safe valve testing
- API 598 — Valve inspection and testing
- MSS SP-54 — Radiography
- MSS SP-55 — Visual quality
- MSS SP-61 — Hydrostatic testing

Durco G4BZ-HF materials of construction

No.	Component	Material
1	Body	A494 M35-1 Monel
2	Plug	A494 M35-1 Monel
3	Top cap	A995 CD4MCuN
3A	Top cap studs	A193 B7M
3B	Top cap nuts	A194 7M
5	Sleeve	TFE (TM or TMHT optional)
6	Diaphragm	PFA
6A	Diaphragm	B127 Monel 400
11	Thrust collar assembly	A995 CD4MCuN/Hastelloy C-276
12	Adjuster	A995 CD4MCuN
12a	Adjuster bolts	A193 B7M
13	Wrench	Ductile iron
17	Grounding spring	302 stainless steel
19	Stop collar	Zinc plated 1018 carbon steel
19a	Stop collar retainer	302 stainless steel
20	Packing	Grafoil
21	Gasket	Grafoil reinforced with Monel wire cloth
22	O-ring	Viton (Kalrez® optional)
23	Backup ring	PTFE

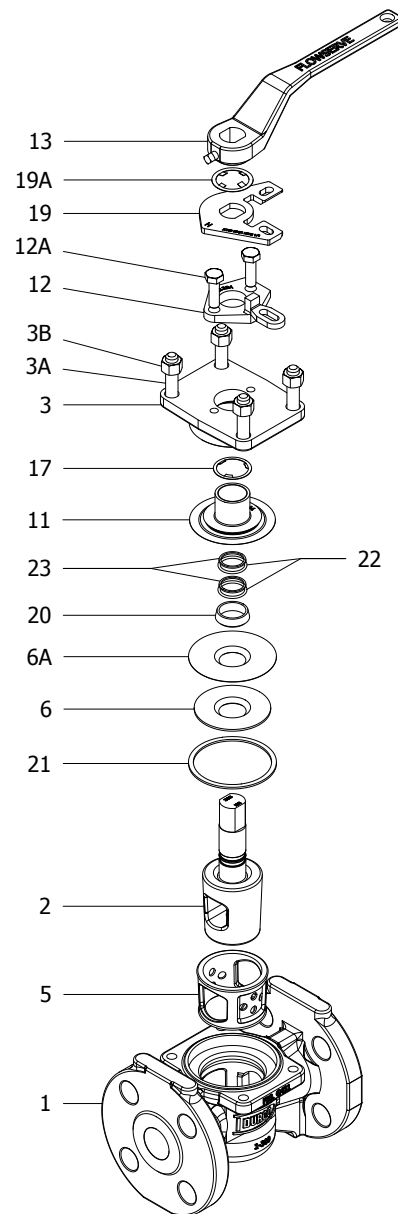

Order drawing numbers – Phillips listed

Valve No.	Size		Drawing No. ⁽⁷⁾
	in	mm	
G4BZ32-HF-.50	½	15	CY77644A
G4BZ32-HF-.75	¾	20	CY77643A
G4BZ32-HF-1	1	25	CY77646A
G4BZ32-HF-2	2	50	(8)
G4BZ31-HFB-2	2	50	DY77648A
G4BZ31-HFB-3	3	80	DY78272A
G4BZ31-HFA-4	4	100	DY78273A
G4BZ31-HFA-6	6	150	DY78274A
G4BZ31-HFA-8	8	200	DY78275A
G4BZ31-HFA-10	10	250	DY78276A
G4BZ31-HF-12	12	300	DY78277A
G4BZ31-HF-14	14	350	DY79037A
G4BZ31-HF-16	16	400	DY82071A
G4BZ31-HF-18	18	450	DY82072A
G4BZ31-HF-20	20	500	(8)
G4BZ35-HF-.50	½	15	(8)
G4BZ35-HF-.75	¾	20	(8)
G4BZ35-HF-1	1	25	(8)
G4BZ35-HF-2	2	50	(8)
G4BZ61-HF (Class 600# flanges and face-to face)	2	50	DY81807A

(7) Refer to Phillips licensing for current revision number.

(8) No Phillips drawing number

Order drawing numbers – UOP listed

Valve No.	Size		Drawing No. ⁽⁹⁾
	in	mm	
G4BZ31-HF	½ to 20	15 to 500	BY82500A
G4BZ32-HF	½ to 2	15 to 50	(10)
G4BZ35-HF	½ to 2	15 to 50	(10)
G4BZ61-HF	2	50	(10)

(9) Refer to UOP licensing for current revision number.

(10) No UOP drawing number



Headquarters

Flowserve Corporation
5215 North O'Connor Blvd.
Suite 2300
Irving, Texas 75039-5421 USA
Telephone: +1 937 890 5839

United States

Flowserve Corporation
1978 Foreman Drive
Cookeville, Tennessee 38501 USA
Telephone: +1 931 432 4021

Germany

Flowserve Ahaus GmbH
Von Braun Straße 19a
D-48683 Ahaus
Germany
Telephone: +49 2561 686-0
Fax: +49 2561 686-39

Singapore

Flowserve Pte. Ltd.
12 Tuas Avenue 20
Republic of Singapore 638824
Telephone: 65 862 3332
Fax: 65 862 2800

Flowserve Corporation has established industry leadership in the design and manufacture of its products. When properly selected, this Flowserve product is designed to perform its intended function safely during its useful life. However, the purchaser or user of Flowserve products should be aware that Flowserve products might be used in numerous applications under a wide variety of industrial service conditions. Although Flowserve can provide general guidelines, it cannot provide specific data and warnings for all possible applications. The purchaser/user must therefore assume the ultimate responsibility for the proper sizing and selection, installation, operation, and maintenance of Flowserve products. The purchaser/user should read and understand the Installation Instructions included with the product, and train its employees and contractors in the safe use of Flowserve products in connection with the specific application.

While the information and specifications contained in this literature are believed to be accurate, they are supplied for informative purposes only and should not be considered certified or as a guarantee of satisfactory results by reliance thereon. Nothing contained herein is to be construed as a warranty or guarantee, express or implied, regarding any matter with respect to this product. Because Flowserve is continually improving and upgrading its product design, the specifications, dimensions and information contained herein are subject to change without notice. Should any question arise concerning these provisions, the purchaser/user should contact Flowserve Corporation at any one of its worldwide operations or offices.

©2018 Flowserve Corporation. All rights reserved. This document contains registered and unregistered trademarks of Flowserve Corporation. Other company, product, or service names may be trademarks or service marks of their respective companies.

DVENTB0025-03-AQ July 2018