



# **Argus<sup>®</sup> FK75F Metal-Seated Floating Ball Valve for Critical Services**



*Experience In Motion*

# Consistent, reliable tight shut-off in critical and severe-duty services

The Argus FK75F metal-seated floating ball valve from Flowserve delivers superior and reliable performance and tight shut-off in severe service conditions, extreme environments and emergency shutdown (ESD) situations.

It is engineered to overcome challenges frequently seen in refinery applications, such as particulates and residue from aggressive media contaminating valves. This buildup can “jam” valves and lead to premature equipment failure, safety concerns and environmental risks.

## Uncompromised performance

The Argus FK75F floating ball design offers tight shut-off and improved reliability compared to other valve types. Due to pressure-assisted loading, the seal created by the floating ball on the primary sealing seat ring tightens as pressure increases.

Its metal-seated, hard-faced seat rings add to its reliability, ensuring uncompromised sealing. The FK75F valve is engineered with finite element analysis (FEA), computational fluid dynamics (CFD), and has physically undergone various heat cycle tests to ensure uncompromising performance during and after the valve thermal cycles.

## Benefits

- Reliable, tight shut-off
- Gas-tight sealing
- Easy to maintain and repair
- Broad application flexibility
- Highly customizable

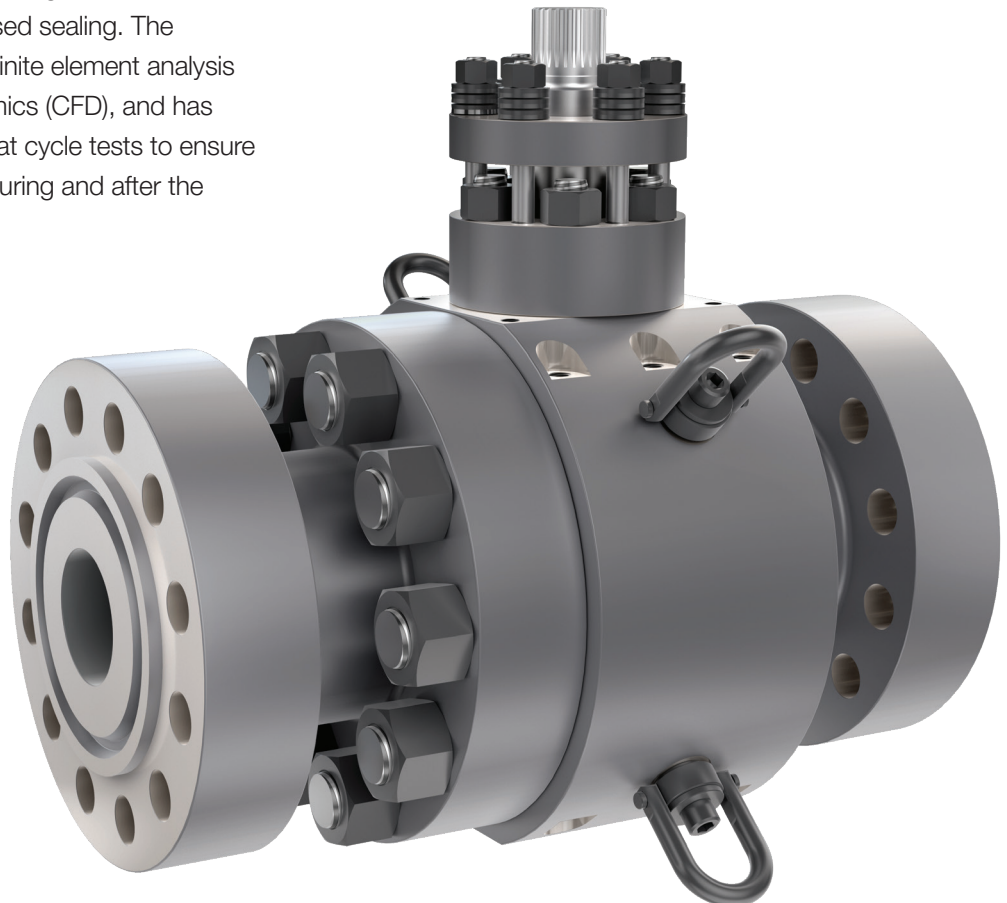





## Built for the toughest applications

The Argus FK75F metal-seated floating ball valve is ideal for critical and severe-duty services where reliable tight shut-off and uncompromising metal sealing are required. These include high-pressure, high-temperature (HPHT) “cracking” applications in refineries, where hydrocarbons are converted into gas, diesel, jet fuel or other upgraded products. They also include applications with abrasive media, such as catalyst and hydrocarbon particulates.

Example applications include, but are not limited to:

- Delayed coking units (DCUs)
- Fluidized catalytic cracking units (FCCUs)
- Hydro processing and cracking (upgraders)
- UOP CCR
- Catalyst handling
- Tower bottoms pump isolation (vacuum and atmospheric tower)
- Emergency shutdown valves (ESDVs)

Although designed for use in refinery environments, the FK75F is well-suited for severe-duty applications in other industries, such as mining and power generation.

- Slurry transport lines
- Choke station bypass
- Superheated steam
- High-pressure feedwater bypass

## Tested to assure quality

All Argus FK75F valves are respectively designed in accordance with ASME B16.34, API 608 and API 598 and tested prior to shipping.

- Visual and dimensional checks
- High-pressure hydrostatic shell test (150% of maximum allowable working pressure [MAWP])
- High-pressure hydrostatic seat test (110% of MAWP)
- Low-pressure pneumatic seat test per API 598 performed at 4 to 7 bar (60 to 100 psig)
- Optional ANSI FCI 70-2 Class VI seat tests

## Designed for continuous reliability and ease of maintenance

A valve is only as reliable as its weakest component. All it takes is a small ring failure to bring a refining operation to a standstill. We designed every part of the Argus FK75F metal-seated floating ball valve using methods and materials to perform successfully in a variety of operating conditions and media types. The result is a versatile, longer-lasting, and more reliable severe service valve that you don't have to worry about.

### Independent sealing systems ensure tight shut-off

The ball, seat rings and spring components work together to continuously seal the media at design application conditions, while the stem drive train components seal the media from escaping into the atmosphere through the stem packing area.

### Solid stem, blowout-proof shafts increase safety

An oversized, one-piece solid stem shaft withstands 200% of operating pressure (torque) and is compliant with API 608 drive train strength requirements. Because the valve stem is constructed as a one-piece design instead of a pinned stem or keyed design, it can more easily open and close against unfavorable media. The absence of pins and keys within the valve reduces failure points. Any potential shearing failure points can be repaired easily, as they are on outside of the valve assembly.

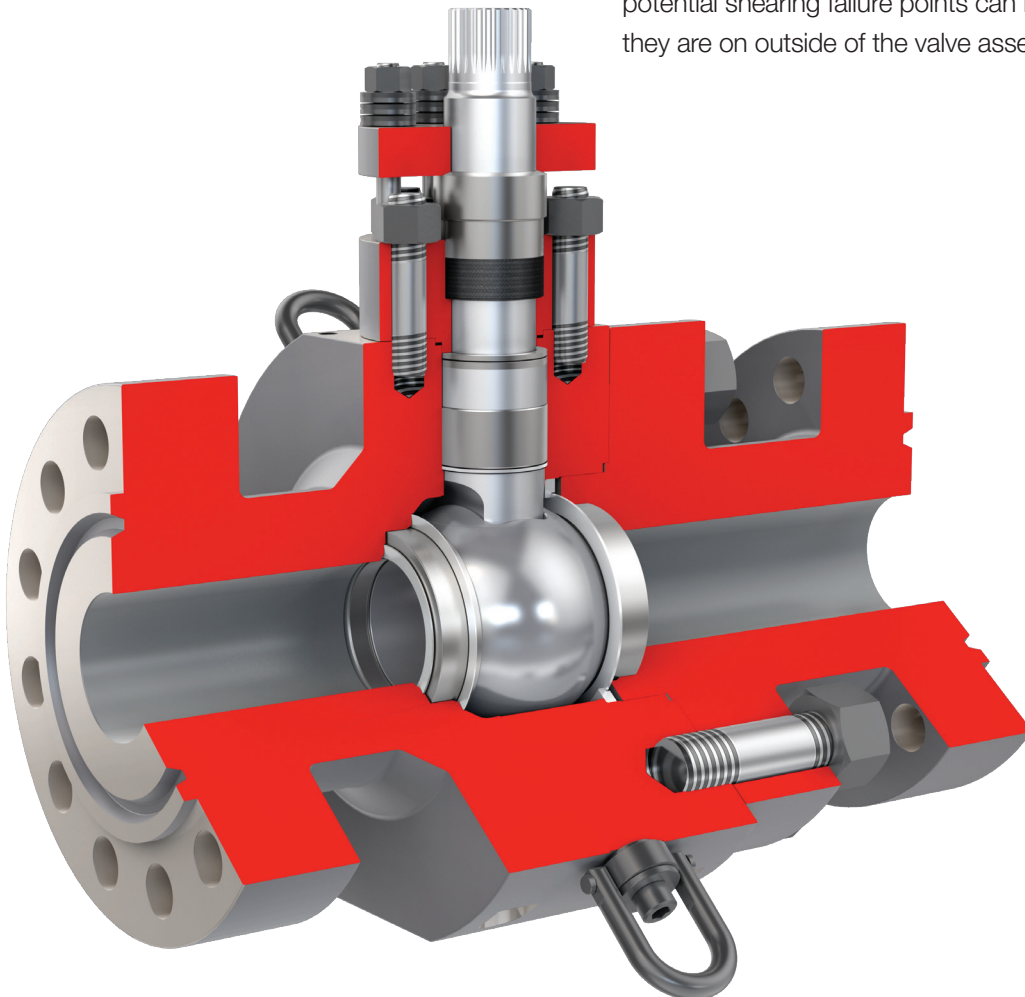

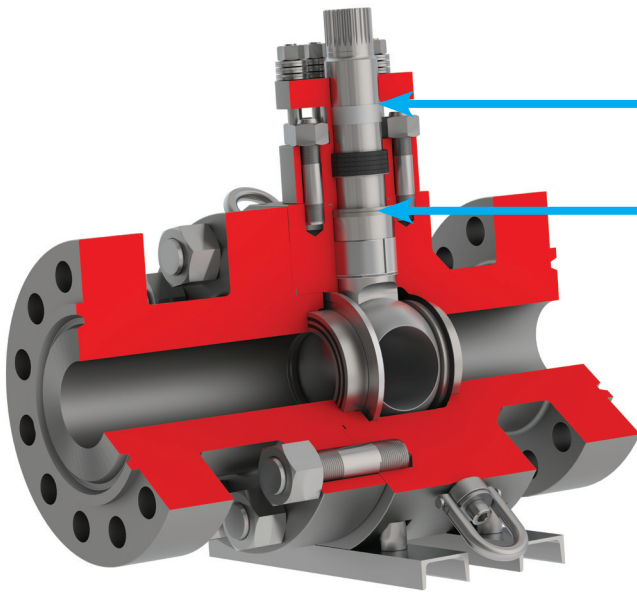

### No side loads on the stem prevents leaking

Inner and outer radial stem bearings help position the stem concentrically within the valve body. This alignment ensures a tight seal and provides a barrier against erosive or corrosive media from leaking into the packing box.

A thrust ring keeps the stem in position and helps to avoid material galling during operation.

### Ease of maintenance saves time and resources

Maintenance of the FK75F valve is fast and easy. No specialized equipment or personnel is required, saving time and resources. Factory-tested spare parts kits can be ordered ahead of scheduled maintenance, minimizing downtime. And, because all trim kits are vacuum tested independently, seal-ability is assured.

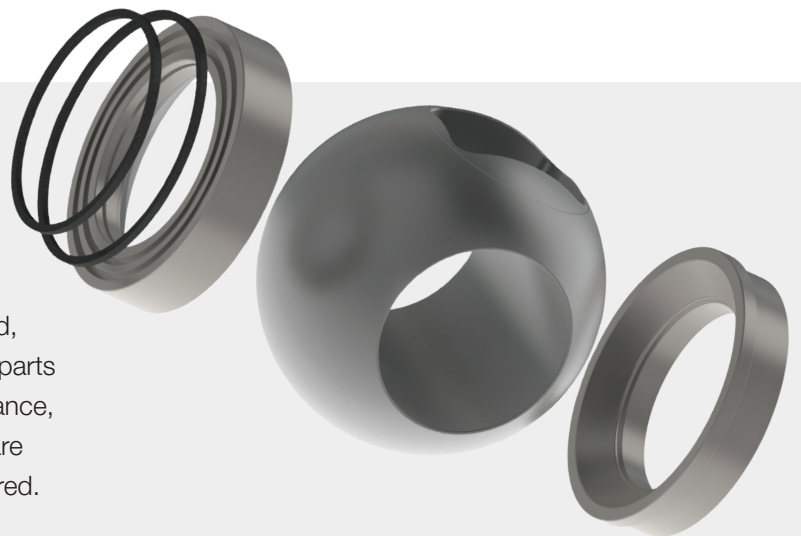

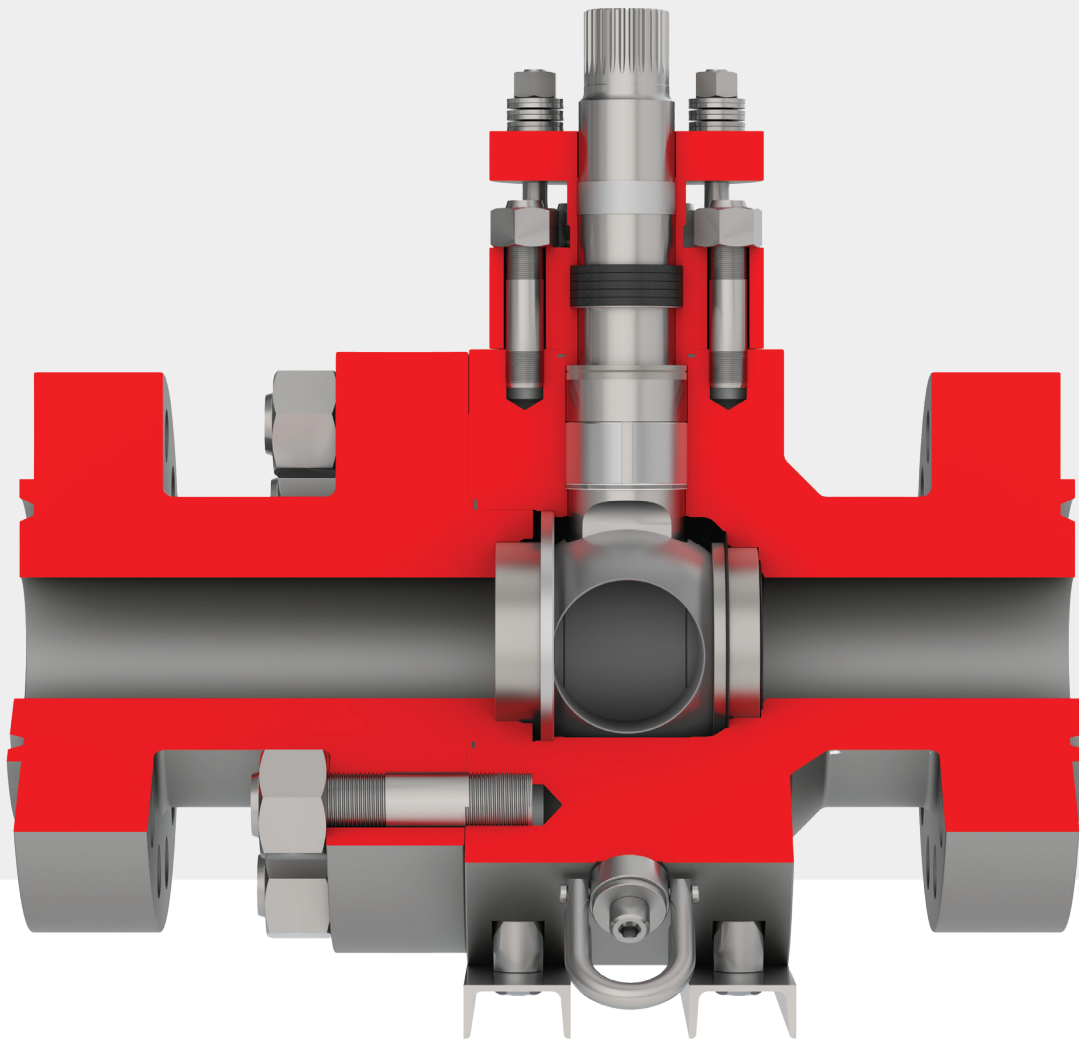

### **“Locked in” primary seat ring won’t shift under reverse pressure**

Because of its unique shape, installation and position, the valve’s primary seat ring is locked and positioned in place by a large Belleville spring. This design ensures the primary seat ring maintains its position and won’t shift under reverse pressure conditions, thus providing continuous and repeatable tight shut-off.

### **Corrosion-resistant materials extend service life**

To ensure consistent and reliable shut-off in the harshest environments, the ball, seat rings and springs use materials and thermally sprayed coatings that resist corrosion and erosion. Springs are made of Inconel®, which has high strength and creep-resistant properties to maximize trim life. They also withstand continuous high-temperature service conditions without deteriorating load capacity.

# Specifications

<b>Sizes</b>	NPS 2 to 12, DN 50 to DN 300 <sup>(1)</sup>
<b>Pressure ratings</b>	ASME Classes 150, 300, 600, 900, 1500 and 2500 <sup>(1)</sup>
<b>Design</b>	ASME B16.34, API 608
<b>End connection</b>	Flanged RF or RJ, buttweld, socket weld, hub <sup>(2)</sup>
<b>Face-to-face dimensions</b>	ASME B16.10
<b>Trim material</b>	Selected based on service application
<b>Hardfacing</b>	Arguloy spray and fused coating, HVOF <sup>(2)</sup>
<b>Stem seal</b>	Graphite packing
<b>Seat configuration</b>	Uni-directional, bi-directional with preferred direction or bi-directional (on request)
<b>Leakage rates</b>	API 598, ANSI FCI 70-2 Class VI
<b>Standard operating temperatures range</b>	-46°C to 538°C (-50°F to 1,000°F) <sup>(3)</sup>
<b>Standard operating pressure range</b>	ASME B16.34 allowable working pressures
<b>Fire-safe</b>	API 607
<b>Fugitive emissions</b>	ISO 15848-1 Class BH, API 641

(1) For sizes smaller than DN 50/NPS 2 and larger than DN 300/NPS 12, please consult factory; maximum available pressure class for NPS up to 36 in. is Class 4500

(2) Other end types available upon request

(3) For temperatures higher than 538°C (1,000°F), please consult factory.





Flowserve Corporation  
5215 North O'Connor Blvd.  
Suite 700  
Irving, Texas 75039-5421 USA

Flowserve Corporation has established industry leadership in the design and manufacture of its products. When properly selected, this Flowserve product is designed to perform its intended function safely during its useful life. However, the purchaser or user of Flowserve products should be aware that Flowserve products might be used in numerous applications under a wide variety of industrial service conditions. Although Flowserve can provide general guidelines, it cannot provide specific data and warnings for all possible applications. The purchaser/user must therefore assume the ultimate responsibility for the proper sizing and selection, installation, operation, and maintenance of Flowserve products. The purchaser/user should read and understand the Installation Instructions included with the product, and train its employees and contractors in the safe use of Flowserve products in connection with the specific application.

While the information and specifications contained in this literature are believed to be accurate, they are supplied for informative purposes only and should not be considered certified or as a guarantee of satisfactory results by reliance thereon. Nothing contained herein is to be construed as a warranty or guarantee, express or implied, regarding any matter with respect to this product. Because Flowserve is continually improving and upgrading its product design, the specifications, dimensions and information contained herein are subject to change without notice. Should any question arise concerning these provisions, the purchaser/user should contact Flowserve Corporation at any one of its worldwide operations or offices.

©2024 Flowserve Corporation. All rights reserved. This document contains registered and unregistered trademarks of Flowserve Corporation. Other company, product, or service names may be trademarks or service marks of their respective companies.

**VABR000308-02 (EN/AQ)** February 2024