

Valtek Position Pac

GENERAL INFORMATION

The following instructions are designed to assist with installing, calibrating and troubleshooting the Valtek® Position Pac™ valve position indicator. Product users and maintenance personnel should thoroughly review this bulletin in conjunction with the maintenance bulletin for the appropriate valve body and actuator being used.

To avoid possible injury to personnel or damage to valve parts, WARNING and CAUTION notes must be strictly adhered to. Modifying this product, substituting non-factory or inferior parts, or using maintenance procedures other than outlined could drastically affect performance, be hazardous to personnel and equipment, and may void existing warranties.

OPERATION

Position Pac is a ‘package’ unit containing a potentiometer and transmitter, two or four limit switches, or a combination of a transmitter and two limit switches.

The position transmitter utilizes a potentiometer to measure the valve’s position and a transmitter circuit that sends a 4 to 20 mA electrical signal to a remote monitoring device. Position Pac will continuously transmit the position of a control valve as it modulates between the open and closed positions.

The limit switches in Position Pac can be independently set to indicate open, closed or any intermediate valve position.

Position Pac’s sealed construction provides protection from the entry of water, dust and oil as defined by the National Electrical Manufacturers Association (NEMA) 1, 3, 3R, 4, 12 and 13. Position Pac is also explosion-proof, providing protection from flammable hydrocarbon atmospheres, metal dust, coal dust, and grain dust. It is UL and CSA listed for Class I, Division 1, Groups B, C, D; Class II, Division 1, Groups E, F, G (See Table I). All electrical wiring should be installed per NEC articles 501-4 and 501-5.

WARNING: Keep hands, hair, clothing, etc. away from moving parts when operating the valve. Failure to do so can cause serious injury.

INSTALLATION INSTRUCTIONS

The following instructions are designed to assist in the field installation of Position Pac units.

Valtek Linear Actuators

To install Position Pac on Valtek linear actuators, refer to Figures 1 and 2, and proceed as follows:

1. Remove the name plate from the yoke leg opposite from the stroke indicator plate.
2. Using the two tapped holes, attach the Position Pac mounting bracket to the yoke leg using two mounting bolts. When facing this yoke leg, the bracket will jog in towards the valve center and protrude to the left.
3. Remove the nut from the stem clamp bolting. Place the tripper bracket on the bolt so the ‘S’ shape extends down. Replace the nut and tighten it firmly.

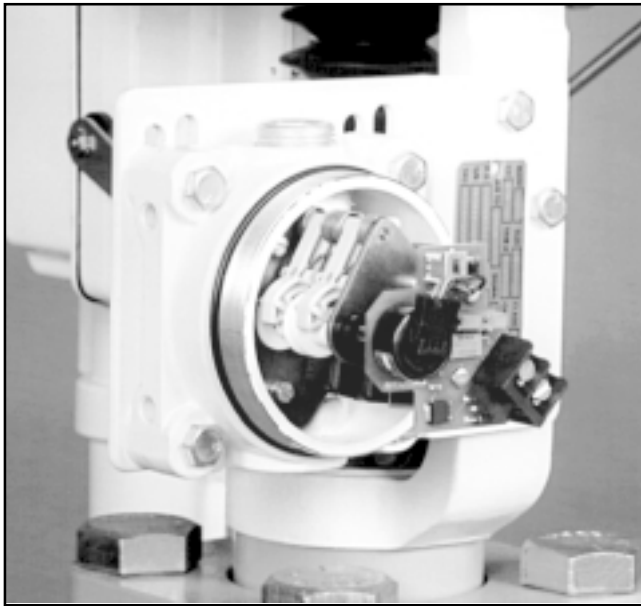

Figure 1: Linear Application – Front View
(cover removed)

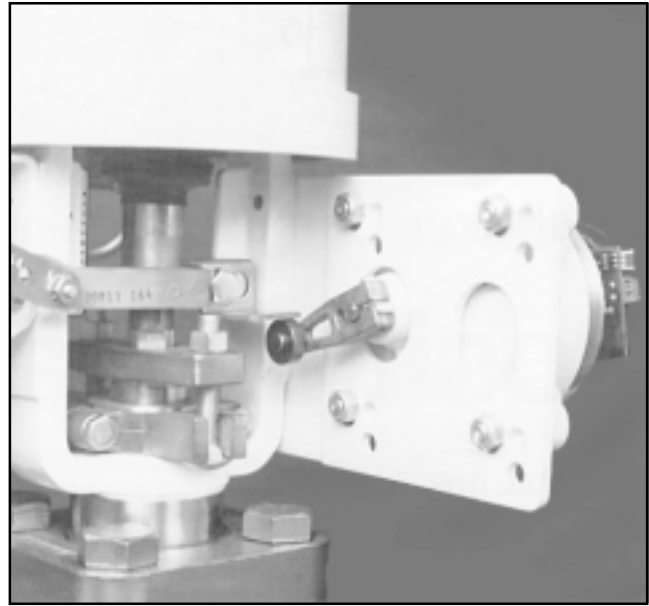

Figure 2: Linear Application – Rear View
(cover removed)

Table I: Model Configuration

Model	Description	Electrical Area								CENELEC Approval	Rating	Sealed Switches	Housing Size
		NEMA 4	Explosion Proof										
			Class I Division 1 & 2 (Group)				Class II Division 1 & 2 (Group)						
A	B	C	D	E	F	G							
TH2	Analog Transmitter with two hermetically sealed SPDT switches										UL	Yes	Long
H2TS	Two hermetically sealed SPDT switches with terminal switch										UL	Yes	Long
TX	Analog transmitter									Pending	UL/CSA	No	Short
TA2	Analog transmitter with two SPDT switches										UL	No	Long
A2	Two SPDT switches										UL	No	Short
A4	Four SPDT switches										UL	No	Long
A2TS	Two SPDT switches with terminal strip										UL	No	Long

Table II: Linear Mounting Information

Actuator Size (sq. in.)	Valve Stroke (inch)	Spud Size (inch)	Kit No.*	Hole Set (Mounting)
25	0.5-1.0	2.00	37434	bottom of slot
	1.5	2.00	37434	top of slot
50	0.5-2.5	2.62	37345	bottom holes
	3.0	2.62	37345	top holes
100 & larger	1.0-3.5	2.62/2.88	37436	bottom holes
	4.0	3.38	37630	top holes
	4.0	4.75	71636	top holes

*Kit includes: bracket, arm, trip lever or stem clamp with trip lever nuts and bolts.

4. Mount Position Pac to the bracket using the mounting holes as specified in Table II: Insert the lever onto the switch shaft. On larger actuators (size 50 and larger) that use the adjustable lever arm, adjust the length so that the center of the roller rests on the center of the tripper bracket. To preload the Position Pac's restoring spring, be certain the control valve is in its minimum signal position. Loosen the lever arm clamp screw with a 0.14-inch (⁹/₆₄) hex wrench, allowing the arm to turn on the shaft. While holding the arm in contact with the bottom of the tripper bracket and using a slotted screwdriver to rotate the switch shaft perform the following (all rotation direction instructions are as viewed from the lever arm side of the Position Pac):

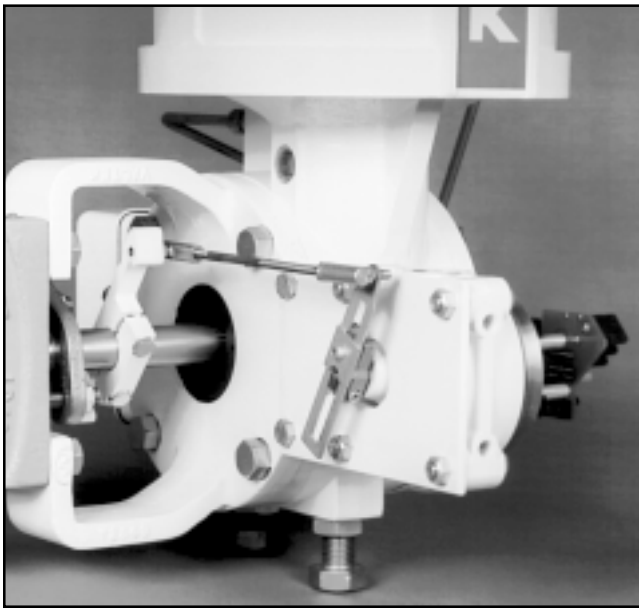

Figure 3: Rotary Application – Rear View
(cover removed; air-to-close valve)

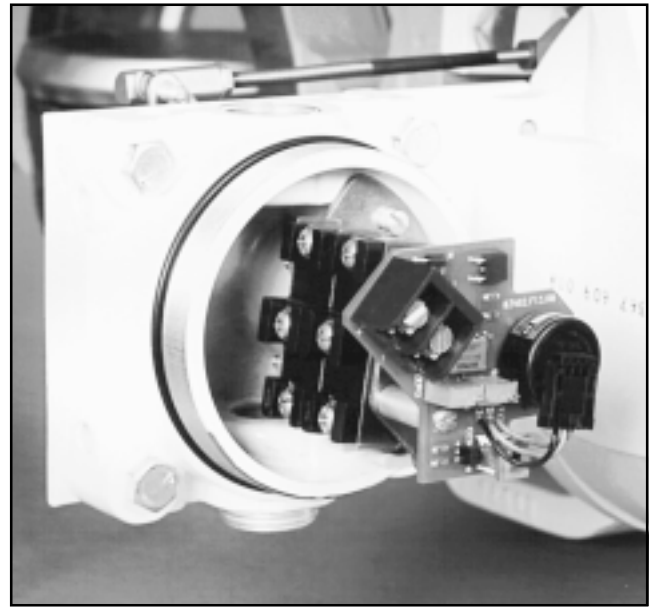

Figure 4: Rotary Application – Front View
(cover removed; air-to-close valve)

For direct-acting, air-to-open actuators, rotate the shaft counter clockwise as far as it will go, then back off approximately 5 to 10 degrees. For direct-acting, air-to-close actuators, rotate the shaft counter clockwise approximately 5 to 10 degrees.

For reverse-acting, air-to-open actuators, rotate the shaft counter clockwise approximately 5 to 10 degrees. For reverse-acting, air-to-close actuators, rotate the shaft counter clockwise as far as possible, then back off approximately 5 to 10 degrees. With the slot in this position, tighten lever arm clamp screw tightly (until the teller tab will not move). With this procedure completed, stroke valve to ensure spring is preloaded throughout the entire valve travel.

5. To make electrical connections, remove the housing cover.

WARNING: On explosion-proof installations, disconnect electrical power or be certain the area is safe from combustible atmospheres before removing the housing cover.

(Refer to the specifications in Table IV for component electrical ratings.) Attach transmitter signal wiring to the transmitter terminal block, using caution to attach the positive and negative wires to the appropriate terminal.

CAUTION: Do not apply a voltage greater than 40 volts to the transmitter terminals or the circuit will be damaged.

Attach limit switch wiring to the 'COMM' (common) and either 'NC' (normally closed) or 'NO' (normally open) terminals according to the needed signal.

6. To adjust the limit switches and/or position transmitter, remove the housing cover and refer to the *Calibration* section in this document.

WARNING: On explosion-proof installations, disconnect electrical power or be certain the area is safe from combustible atmospheres before removing the housing cover.

7. Replace the housing cover.
8. Reinstall the name plate to the mounting bracket.

NOTE: Name plate reinstallation is important for valve identification/servicing purposes.

Valtek Rotary Actuators

To install Position Pac on Valtek rotary actuators, refer to Figures 3 and 4, and proceed as follows:

1. Mount the bracket to the mounting pad on the backside of the actuator using two 0.31-inch ($\frac{5}{16}$) mounting bolts.
2. Mount the Position Pac to the bracket using four 0.31-inch ($\frac{5}{16}$) mounting bolts and nuts.
3. Loosely mount the trip lever to the valve shaft within the yoke.
4. Attach the switch lever to the Position Pac shaft.
5. Connect the linkage assembly to both levers as shown in Figure 3.
6. Measure the approximate radius of the trip lever from the center of the valve shaft to the linkage assembly connection (**not the end of the lever**). Next, adjust the switch lever to approximately the same radius and tighten.

Table III: Rotary Mounting Kits

Actuator Size (sq. in.)	Valve Shaft Diameter (inches)	Kit No.*
25	0.62	97556
25	0.75	97557
25	0.88	97558
50	0.62	97559
50	0.75	97560
50	0.88	97561
50	1.12	97562
100	0.88	97563
100	1.12	97564
100	1.50	97565
100	1.75	97566

*Kit includes: bracket, trip lever, switch lever, linkage assembly, nuts and bolts.

7. With the actuator at its minimum signal position, slide the trip lever along the shaft until the linkage assembly is parallel to the mounting bracket. At the same time, rotate the trip lever until it is at a 45-degree angle to the mounting bracket and pointing toward the top yoke bolt closest to the Position Pac. Tighten the trip lever on the shaft in this position.
8. Adjust the linkage assembly until the switch lever is approximately the same angle as the trip lever and the linkage assembly is horizontal. To preload the Position Pac's restoring spring (used to remove backlash in the linkage), be certain the actuator is in its minimum signal position and perform the following using a slotted screw driver to rotate the switch shaft (all rotation direction instructions are as viewed from the lever arm side of the Position Pac):

For direct-acting, air-to-open actuators, rotate the shaft counter clockwise as far as it will go, then back off approximately 5 to 10 degrees. For direct-acting, air-to-close actuators, rotate the shaft clockwise approximately 5 degrees.

For reverse-acting, air-to-open actuators, rotate the shaft clockwise approximately 5 degrees. For reverse-acting, air-to-close actuators, rotate the shaft counter clockwise as far as possible, then back off approximately 5 to 10 degrees.

With the slot in this position, tighten the lever arm clamp screw tightly (until the teller tab will not move).
9. If possible, stroke the valve; the linkage assembly should travel back and forth remaining horizontal.
10. To make electrical connections, remove the housing cover. (Refer to the specifications in Table IV for the component electrical ratings.) Attach the transmitter signal wiring to the transmitter terminal block, using caution to attach the positive and negative wires to the appropriate terminal. Attach the limit switch signal wiring to 'COMM' (common) and either

'NC' (normally closed) or 'NO' (normally open) terminals according to the needed signal.

WARNING: On explosion-proof installations, disconnect electrical power or be certain the area is safe from combustible atmospheres before removing the housing cover.

11. To adjust the limit switches and/or the position transmitter, remove the housing cover and refer to the *Calibration* section in this document.
12. Replace the housing cover.

CALIBRATION

When a Position Pac is installed in the field or a factory installed unit needs to have output signal adjustments made, refer to Figure 5 and proceed as follows:

Limit Switch

Position Pac limit switches are adjusted at the factory before shipment and should not require on-site adjustment. However, if the mechanical lever has shifted position, the unit may need readjustment. To readjust the limit switch, proceed as follows:

CAUTION: If the valve cannot be stroked without disturbing the process fluid, bypassing or removing the valve from the line may be necessary before calibrating the Position Pac.

WARNING: Prior to removing the valve from the line, depressurize the line to atmospheric pressure, drain all process fluid and, if caustic or hazardous material are present, decontaminate the valve. Failure to do so can cause serious injury.

1. Stroke the valve to the closed position.

WARNING: Keep hands, hair, clothing, etc. away from moving parts when operating the valve. Failure to do so can cause serious injury.
2. Remove the housing cover from the Position Pac.

WARNING: On explosion-proof installations, disconnect electrical power or be certain the area is safe from combustible atmospheres before removing the housing cover.
3. Lift the appropriate cam follower lever. Move the cam wheel axially to disengage the teeth on the wheel from the teeth on the shaft disc.
4. Turn the cam wheel to the desired position. Each notch on the cam wheel represents an operating point change of 7° 20'.
5. When the cam wheel has been rotated to the desired location, slide the cam wheel to engage with the mating shaft disc. (For finer adjustment, use the setscrew in the cam follower.)
6. Release the cam follower lever.
7. Cycle the valve and check for proper adjustment. Readjust if necessary.
8. Replace the housing cover.

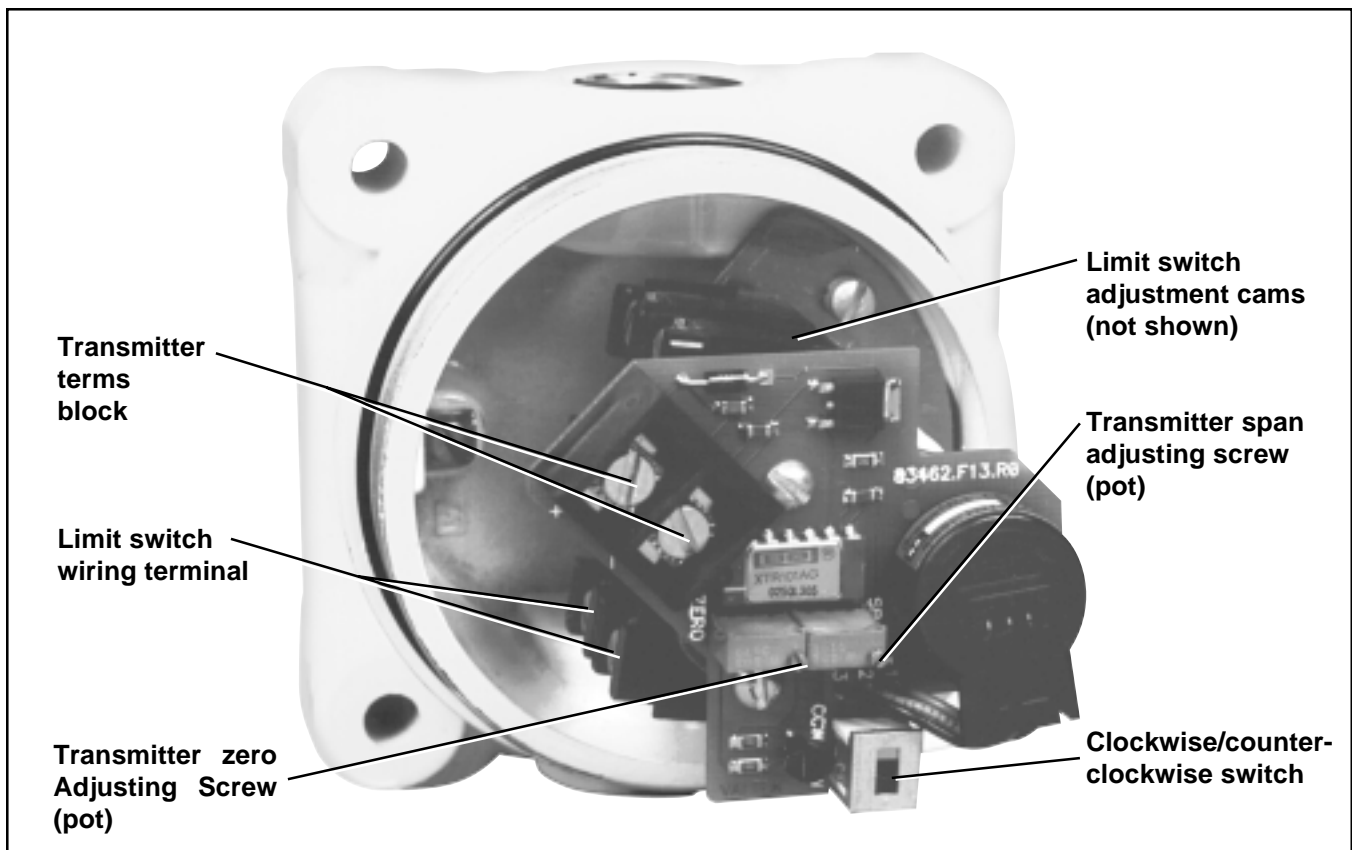

Figure 5: Calibration Points

Position Transmitter

1. Remove the housing cover from the Position Pac.

WARNING: On explosion-proof installations, disconnect electrical power or be certain the area is safe from combustible atmospheres before removing the housing cover.

2. Wire the Position Pac transmitter in series with a 12.5-40 VDC power supply and a milliamp meter.

NOTE: Instructions within parenthesis () refer to older Position Pac models characterized by a white label.

CAUTION: Do not apply a voltage greater than 40 volts to transmitter terminals or the circuit will be damaged.

3. Be certain the CW/CCW Switch located next to the potentiometer (Direct/Reverse Switch located next to the wire terminal block) is set to provide the desired output signal action. In the CW (DIR) position, a clockwise rotation of the Position Pac shaft will cause the output signal to increase. In the CCW (REV) position, a counterclockwise stem rotation causes the signal to increase.
4. Stroke the valve to the closed position.

WARNING: Keep hands, hair, clothing, etc. away from moving parts when operating the valve. Failure to do so can cause serious injury.

5. Referring to Figure 5, adjust the ZERO adjusting screw with a small, straight end screw driver, until the meter reads 4 mA DC.
6. Stroke the valve to the open position.
7. Adjust the SPAN adjusting screw until the meter reads 20 mA DC.
8. Stroke valve to the closed position and recheck the meter for 4 mA DC. Some readjusting of the calibration may be required. Repeat steps 4-8 until satisfied.
9. If calibration is unsuccessful after following this procedure, one of two problems may exist: (a) The orientation of the Position Pac stem may need to be adjusted. (b) The ZERO and SPAN potentiometers may be adjusted out of range.

NOTE: The electrical travel of the potentiometer is 340 (150) degrees. To operate properly, the potentiometer wiper must stay within the center 185 degrees of its 340 degree electrical range during the full stroke of the valve.

- 9a. To adjust, stroke the valve to its middle position. Loosen the potentiometer collar nut. While measuring the voltage between pins 1 and 2 on the back of the potentiometer, rotate the potentiometer until the voltage is between 0.55 and 0.65 volts. Retighten the potentiometer being careful to keep the potentiometer oriented in the same position.

- 9b. Set the ZERO and SPAN potentiometers to their approximate middle position. This is accomplished by first turning each potentiometer clockwise 25 turns or until a 'click' is either felt or heard. Then turn each potentiometer counterclockwise approximately 12 complete turns. Repeat steps 2 through 8 to complete calibration.
10. Replace the housing cover.

REVERSING POSITION TRANSMITTER SIGNAL

The following instructions should be used when the signal being transmitted from the position transmitter is either incorrect or needs to be reversed. Refer to Figure 5.

NOTE: Instructions within parenthesis () refer to older Position Pac models characterized by a white label.

1. Remove the housing cover.

WARNING: On explosion-proof installations, disconnect electrical power or be certain the area is safe from combustible atmospheres before removing the housing cover.
2. Locate the switch next to the position transmitter's wiring terminal. Move switch to the opposite position, CCW or CW (DIR or REV). Repeat steps 3-9 in the *Calibration* section for the position transmitter.

NOTE: The SPAN potentiometer will generally not need readjustment.
3. Replace the housing cover.

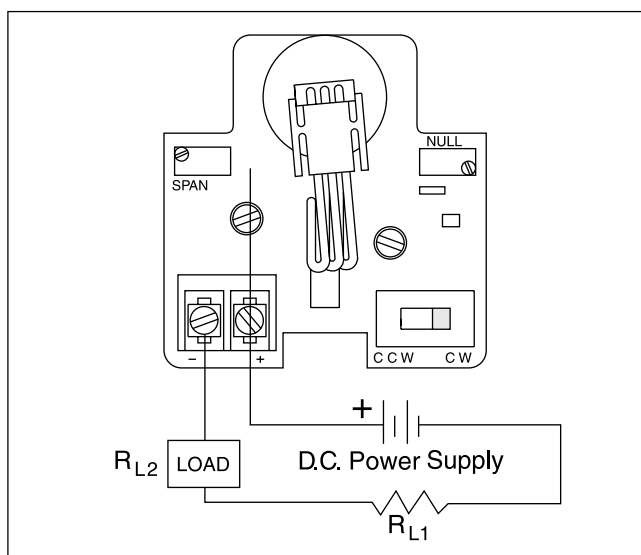

Figure 6: Wiring Diagram

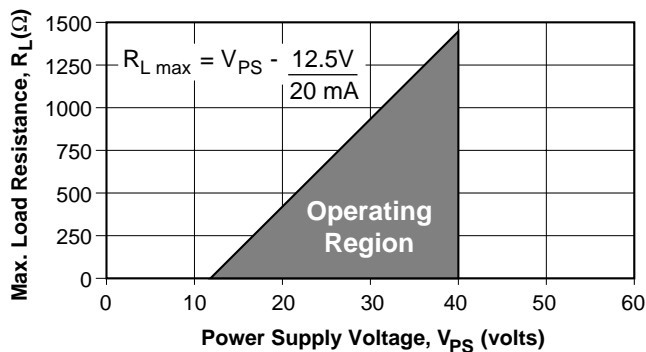

Figure 7: Power Supply Requirements

Table IV: Specifications

Analog Output

Power Supply Range	12.5 to 40 VDC (24V DC typical)
Maximum Load Resistance (see Figure 3)	Maximum Resistance (ohms) = $\frac{\text{Supply Voltage} - 12.5}{0.02}$
Current Signal Output	4-20 mA
Span	Adjustable from 5° to 100° of angular rotation
Null	4 mA position may be set at any angular position
Linearity	±1.0% full-scale*
Repeatability	±0.25% full-scale
Hysteresis	±1.0% full-scale
Operating Temperature Range	-40° to 185° F (-40° to 85° C)
Ambient Temperature Range	For a 100° F (38° C) change in ambient temperature, maximum zero shift is ±0.4% full scale, maximum span shift is ±0.7% full scale
Power Supply	Output signal changes less than 0.05% when supply voltage is varied between 12.5 and 40 volts dc

Limit Switches

(SPDT) UL/CSA Rating (L23)	20 amps, 125, 250, 480 VAC, ind. and res. 1 Hp, 125 VAC; 2 Hp, 250 VAC, 0.5 amp, 125 VDC; 0.25 amp, 250 VDC res.
-------------------------------	--

Mechanical

Input motion	±105° from the center; spring loaded to return to the center
--------------	--

* Linearity is ±1.0% for 90° rotary shaft input. When mounted to linear travel valves, linearity is dependent on linkage design and stroke length. Typical linearity is ±1.5% full-scale on Valtek Mark One control valves.

Rotary

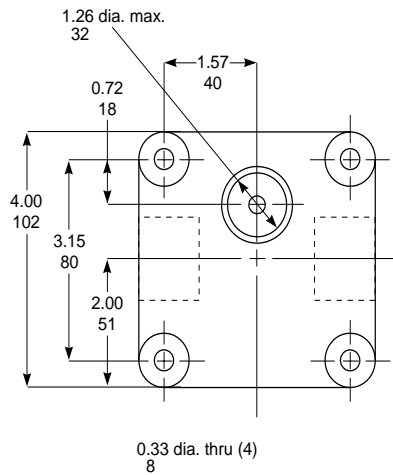

Short Housing

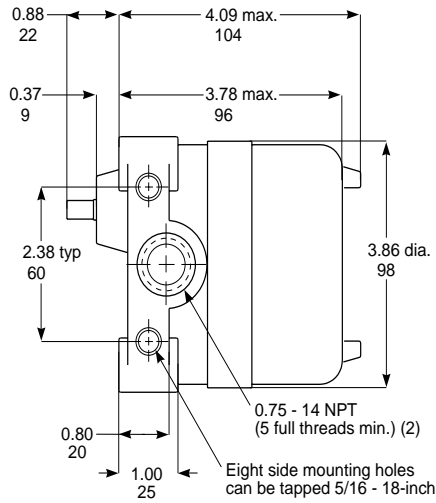

Long Housing

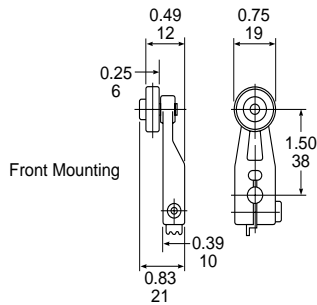
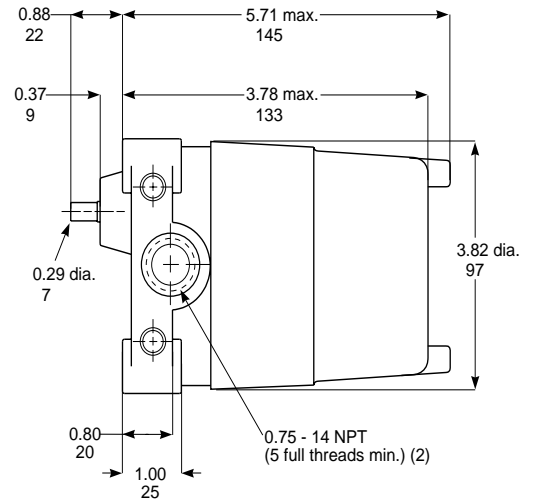

Lever Actuators

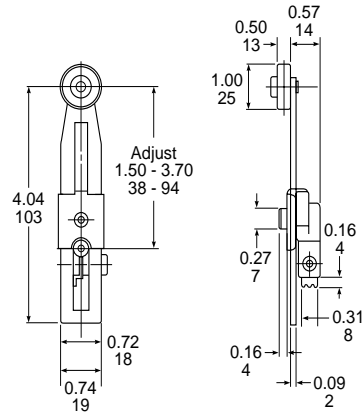

Figure 8: Dimensions

Troubleshooting

Failure	Probable Cause	Corrective Action
Operation erratic and inconsistent	1. Loose bracket bolting	1. Tighten bolting bracket to yoke leg or transfer case: readjust position transmitter and switches
	2. Loose Position Pac mounting screws	2. Tighten mounting screws, readjust position transmitter and switches
	3. Loose tripper bracket (linear actuator) or extended spline connector (rotary actuator)	3. Tighten tripper bracket or extended spline connector
	4. Internal or electrical malfunction	4a. Ensure that terminal block connections are tight
		4b. Check for foreign material in contact with printed circuit board or components
4c. Check for components or wires broken loose from printed circuit board		
4d. Check that the switch is fully set in desired position		
Indicating incorrect position	1. Incorrect adjustment	1. Refer to <i>Calibration</i> section, step 9
	2. Internal or electrical	2a. Ensure that terminal block connections are tight
		2b. Check for foreign material in contact with printed circuit board or components
		2c. Check for components or wires broken loose from printed circuit board
		2d. Check that the switch is fully set in desired position

Flowserve Corporation has established industry leadership in the design and manufacture of its products. When properly selected, this Flowserve product is designed to perform its intended function safely during its useful life. However, the purchaser or user of Flowserve products should be aware that Flowserve products might be used in numerous applications under a wide variety of industrial service conditions. Although Flowserve can (and often does) provide general guidelines, it cannot provide specific data and warnings for all possible applications. The purchaser/user must therefore assume the ultimate responsibility for the proper sizing and selection, installation, operation and maintenance of Flowserve products. The purchaser/user should read and understand the Installation Operation Maintenance (IOM) instructions included with the product, and train its employees and contractors in the safe use of Flowserve products in connection with the specific application.

While the information and specifications presented in this literature are believed to be accurate, they are supplied for informative purposes only and should not be considered certified or as a guarantee of satisfactory results by reliance thereon. Nothing contained herein is to be construed as a warranty or guarantee, express or implied, regarding any matter with respect to this product. Because Flowserve is continually improving and upgrading its product design, the specifications, dimensions and information contained herein are subject to change without notice. Should any question arise concerning these provisions, the purchaser/user should contact Flowserve Corporation at any of its worldwide operations or offices.

For more information, contact:

For more information about Flowserve, contact www.flowserve.com or call USA 972 443 6500

Regional Headquarters

1350 N. Mt. Springs Prkwy.
Springville, UT 84663
Phone 801 489 8611
Facsimile 801 489 3719

12 Tuas Avenue 20
Republic of Singapore 638824
Phone (65) 862 3332
Facsimile (65) 862 4940

12, av. du Québec, B.P. 645
91965, Courtaboeuf Cedex,
France
Phone (33 1) 60 92 32 51
Facsimile (33 1) 60 92 32 99

Quick Response Centers

5114 Railroad Street
Deer Park, TX 77536 USA
Phone 281 479 9500
Facsimile 281 479 8511

104 Chelsea Parkway
Boothwyn, PA 19061 USA
Phone 610 497 8600
Facsimile 610 497 6680

1300 Parkway View Drive
Pittsburgh, PA 15205 USA
Phone 412 787 8803
Facsimile 412 787 1944

