

Valtek® Mark Six™ Cryogenic Service Control Valves

Installation, Operation,
Maintenance Instructions



Mark Six Cryogenic Service Control Valves

General information	2
Unpacking	2
Installation	3
Quick-check.....	3
Startup	3
Valve maintenance.....	3
Disassembly and reassembly	
Disassembling the actuator.....	3
Disassembling the plug.....	3
Replacing the soft seat	4
Inspecting the seat ring.....	4
Reassembly of the Mark Six	4
Removing the actuator	6
Reassembling the actuator	6
Troubleshooting	7

General information

The following instructions are designed to assist in unpacking, installing and performing maintenance required for the Valtek Mark Six cryogenic service control valves.

To avoid possible injury to personnel or damage to valve parts, WARNING and CAUTION notes must be strictly adhered to. Modifying this product, substituting non-factory or inferior parts, or using maintenance procedures other than outlined herein could drastically affect performance, void product warranties, and be hazardous to personnel and equipment.

The Valtek Mark Six is a globe-style, single-seat, top-entry valve with a fabricated cold box extension for use in cryogenic applications down to -253°C (-423°F). Body weight is kept to a minimum to reduce boil-off during valve cool-down. The extension design permits easy access and removal of the valve trim through the cold box. The Mark Six utilizes a spring-energized PTFE seal or a small vent hole through the plug seal area to permit only a small amount of liquefied gas into the bonnet areas, where it vaporizes and provides a vapor barrier between the liquefied gas and the packing. The pressure resulting from the vaporization of the liquid keeps any more liquid from passing into the bonnet area. (The small amount of vaporized liquid is not sufficient to produce high pressures at shutdown).

Terms concerning safety

The safety terms DANGER, WARNING, CAUTION and NOTE are used in these instructions to highlight particular dangers and/or provide additional information on aspects that may not be readily apparent.

 **DANGER:** indicates that death, severe personal injury and/or substantial property damage will occur if proper precautions are not taken.

 **WARNING:** indicates that death, severe personal injury and/or substantial property damage can occur if proper precautions are not taken.

 **CAUTION:** indicates that minor personal injury and/or property damage can occur if proper precautions are not taken.

 **NOTE:** indicates and provides additional technical information, which may not be very obvious, even to qualified personnel. Compliance with other, not particularly emphasized notes, with regard to transport, assembly, operation and maintenance and with regard to technical documentation (e.g., in the operating instruction, product documentation or on the product itself) is essential, in order to avoid faults, which might directly or indirectly cause severe personal injury or property damage.

Unpacking

1. Before installation, check the packing list against the materials received. Lists describing the valve and accessories are included with each valve.
2. When lifting valve from shipping container, position lifting straps to avoid damage to tubing and mounted accessories. Most valves may be lifted by the actuator lifting ring. If one is not provided, use lifting straps around yoke legs to lift valve.
3. In the event of shipping damage, contact your shipper immediately.
4. Should any problem arise, contact your Flowserve Control Products representative.

Installation

Mark Six valves with a vented plug should be installed with the extension and actuator at an angle $\geq 25^\circ$ from horizontal. Mark Six valves with the spring-energized plug seal design may be installed on an angle $< 25^\circ$ from horizontal. For any questions or clarification, please contact the factory.

1. Before installation, clean the line of all dirt, scale, welding chips and other foreign material.
2. Check flow direction to be sure the valve is installed correctly. Flow should be over the plug for fail-closed valves, and under the plug for fail-open valves. Flow direction is indicated by an arrow on the bonnet flange.
3. Provide proper overhead clearance above the actuator to allow for actuator removal and trim inspection, should it be necessary. Disassembly clearance depends on the length of the cold box extension and the valve size. To estimate required clearance, add the length of the extension to the appropriate distance (shown in Table 1) for the particular valve size.

Table 1: Disassembly clearance (in)

Valve Size	$\frac{1}{2}$, $\frac{3}{4}$, 1	$1\frac{1}{2}$, 2	3	4	6
Recommended Distance	3	5	6	8	10

Quick-check

Prior to startup, stroke the control valve. As the instrument signal is changed, observe the plug position as shown by the stroke indicator plate.

1. Check for full stroke by making appropriate instrument signal change (such as 3-15 psi or 4-20mA).
2. Check all air connections for leaks.
3. Evenly tighten packing nuts to 3 to 6 flats over finger-tight.

⚠ CAUTION: Do not overtighten packing. This can cause excessive packing wear and high stem friction, which may impede stem movement.

4. After valve has been in operation a short time, readjust packing to 3 to 6 flats over finger-tight.
5. Stroke valve to make sure that it fails in the right direction in case of air failure, and that the combined actions of the controller, positioner and valve will provide control of the flow.

Startup

⚠ WARNING: On valves with spring-energized seals, it may take hours or even a day for enough liquefied gas to pass into the bonnet area to effectively “balance” the pressure across the plug seal. In the event of air failure in a fail-closed valve during this time, fluid forces may tend to open the valve rather than close it because the effective area of the plug seal is greater than the effective seat area. Once enough vapor has accumulated in the bonnet area, the pressures on each

side of the plug will equalize and normal valve operation results. Valves with vented designs are available that do not require time to “balance” the pressure across the plug head.

Valve maintenance

The Valtek Mark Six top-entry design allows for easy trim inspection and service without removing the valve body from the line or the insulation from the valve to get at the bonnet and the trim.

Routine maintenance consists of tightening the gland flange nuts to compensate for packing wear. Do not overtighten packing nuts, since this will shorten packing life and may prevent smooth valve performance.

Disassembly and reassembly

⚠ WARNING: Depressurize the line to atmospheric pressure and drain all fluids before working on the valve. Failure to do so can cause serious injury.

Removing the actuator and plug assembly

1. Fully retract plug until stroke indicator is pointing to the open position (air to the actuator may be required).
 2. Remove the bonnet bolts and lift the actuator, bonnet and plug out of the valve.
- ⚠ CAUTION: The plug head seals may cause the plug to bind in the body, making it difficult to remove the actuator/plug assembly. To remove the plug in this situation, apply air to the top of the actuator piston, moving the actuator cylinder and bonnet away from the plug head. Place soft (such as wood) blocking of equal thickness in at least three positions between the valve body and the bonnet. Apply air underneath the actuator piston to retract the plug.**
3. Lift the plug carefully out of the body. Any scraping of parts while removing the plug may cause damage. Heavy actuators may require a hoist. If the actuator is not equipped with a lifting ring, use lifting straps around the yoke legs.

Disassembling the plug from the actuator

1. Loosen the stem clamp.
 2. Loosen the gland flange.
 3. Remove the yoke clamp (or yoke bolts if used).
 4. Rotate the actuator in a counterclockwise direction to disengage the plug stem from the actuator stem.
- ⚠ CAUTION: To avoid scoring guides and stem, do not turn plug stem in bonnet. Flats are machined on the plug stem so it can be held with a wrench.**
5. Carefully remove plug by pulling it through the bonnet.
 6. Push out packing and guides from the bottom of the bonnet, using a dowel.
 7. Inspect guides for scratches and scoring. Damaged guides should be replaced and new packing should be used upon reassembly.

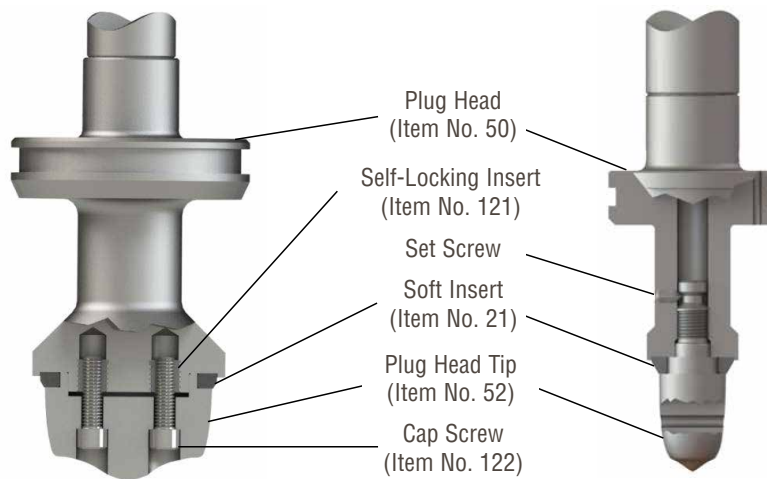

Bolted plug head (TN 1.62 and larger)

Threaded plug head (TN 1.50 and smaller)

Figure 1: Soft seat plug head comparison

Item numbers correspond to the valve's bill of material. Refer to it for specific part numbers.

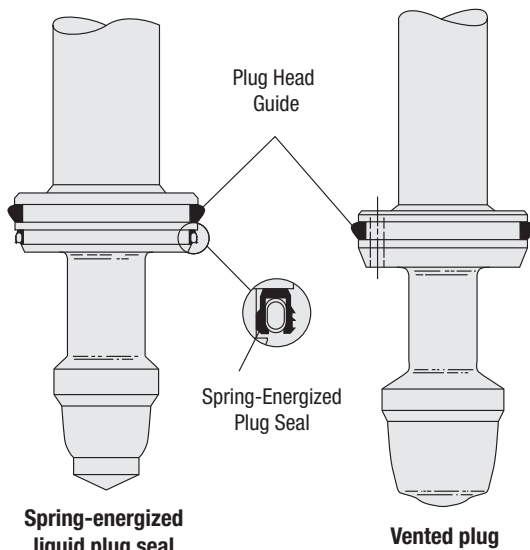

Figure 2: Plug seal comparison

Replacing the soft seat

1. Disassembling the plug.

NOTE: Plugs with trim numbers to 1.5 in use a threaded plug head design that clamps the soft insert between the plug head tip and plug head. Disassemble the plug by removing the set screw and screwing the plug head tip out of the plug head. A rod may be inserted into the hole drilled through the plug head tip to facilitate removal.

Plugs with trim numbers above 1.62 in use a bolted design that clamps the soft insert between the plug head tip and plug head. Disassemble the plug by removing the cap screws.

2. Clean all parts.
3. Using a new elastomeric insert, reassemble soft seat components as shown.

NOTE: On small threaded plug heads, make sure the plug head is screwed in tightly to compress the soft insert between the plug head and the plug head tip. A set screw prevents the plug head tip from working loose. Refer to Table 4 for the recommended torque values.

Inspecting the screwed-in seat ring

1. Unscrew the seat ring using the correct seat ring assembly tools. Assembly tools are available from Flowserve by referencing Table 2.

NOTE: Flats are machined on the tool, so a wrench may be used to turn the seat ring. Assembly tool supports are sometimes needed to keep the assembly tool aligned properly in the seat ring. See Figure 4.

2. If necessary, remachine the seat surface. The seat angle on the seat ring is 33 degrees from the vertical axis.

CAUTION: Ensure concentricity of seating surface with the outside diameter of the seat ring.

3. Install seat ring using a seat ring assembly tool and tighten to the appropriate torque value shown in Table 2.

Reassembly of the Mark Six

1. Install a new bonnet gasket.
2. Carefully lower plug as far as it will go into the body.
3. Slide the bonnet/actuator assembly over plug stem.
4. Insert guides and packing into the bonnet.
5. Place the gland flange onto the plug stem.
6. Screw the actuator stem onto the plug stem by rotating the actuator in a clockwise direction.

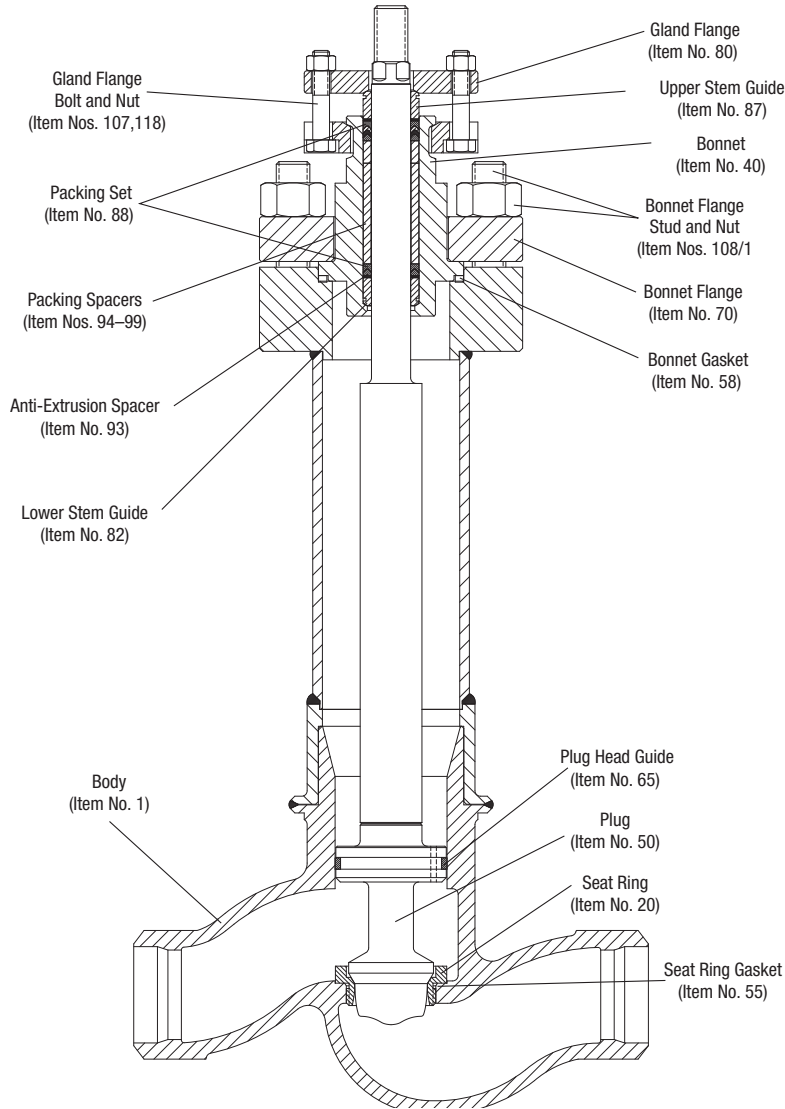

Figure 3: Mark Six control valve
Item numbers correspond to the valve's bill of material. Refer to it for specific part numbers.

CAUTION: Do not allow plug to rotate. Leave two or three threads exposed for air-to-close valves. For air-to-open valves, screw the plug stem as far as it will go into the actuator stem.

7. Assemble yoke clamp or tighten the yoke bolts.
8. Cycle the valve to retract the plug.
9. The plug head seals, when used, make it necessary to drive the plug into the body using the actuator. Partially bolt down the bonnet flange and supply air to upper actuator port to extend the plug. Repeat operation, if necessary, to bring bonnet fully down into the body.

10. Tighten two opposing bonnet bolts one-sixth turn. Tighten all bonnet bolts one-sixth turn at a time, alternating between opposing bolts. Firmly tighten all nuts evenly and completely, using full wrench force to compress the gasket and seat the bonnet metal-to-metal in the body. Recommended bonnet bolting torques are given in Table 3.

CAUTION: Insufficient bonnet bolt tightening will result in improper gasket compression.

Table 2: Seat removal tools and seat torque values

Valve Size (in)	Trim No.	Handle Kit No.*	Head Kit No.	Recommended Torque (ft-lb/N-m; +/-10%)		
0.5-1.0	0.12	165081.999	165088.999	28/38		
	0.25					
	0.38					
	0.50					
0.75-1.0	0.62					
	0.75					
	0.81					
	1.00				143434.999	
1.5	1.25				143359.999	33/45
2	1.62				143360.999	60/82
3	2.62	143362.999	80/109			
4	3.50	143361.999	135/184			
6	4.00	165217.999	165212.999	200/272		
6	5.00		165215.999			

*Handle lengths are 40 in long.

Table 3: Bonnet bolting torques

Bonnet Bolt Size (in)	Recommended Bonnet Bolt Torque (ft-lb/N-m; +/-10%)
5/8	50 / 68
3/4	90 / 122
7/8	150 / 203
1	220 / 298
1-1/8	330 / 447
1-1/4	460 / 624
1-3/8	630 / 854
1-1/2	840 / 1140

Table 4: Plug head bolting torques

Plug Head Cap Screw Size (in)	Recommended Cap Screw Torque (ft-lb/N-m; +/- 10%)
3/16	0.6 / 0.9
1/4	1.6 / 2.2
5/16	4 / 5
3/8	6 / 9
7/16	10 / 14
1/2	16 / 22
9/16	24 / 32
5/8	33 / 45

11. Adjust stem engagement for air-to-open valves only, using the following procedure.

NOTE: Proper stem engagement is essential on air-to-open valves to provide stiff, stable operation as the valve throttles near the seat.

Cycle the valve to closed position. Observe plug position as shown by the stroke indicator plate. This position is the bottom of the actuator piston stroke.

Cycle the valve to open position. Screw the plug out of the actuator one-half turn. Cycle the valve to closed position. Observe the plug position as indicated by the stroke plate. Repeat this procedure, comparing plug position each time until the indicated plug position is about 1/8 in above the initial or bottom position. This procedure must be followed to assure stiff stable operation as well as tight shutoff. Tighten all nuts evenly and completely, using full wrench force to compress the gasket and seat the bonnet metal-to-metal in the body. Proper tightness requires considerable force; however, the bottoming of the parts metal-to-metal can easily be felt through the wrench. Refer to Table 3 for the recommended torque values.

- Tighten the stem clamp.
- Tighten packing nuts to slightly over finger-tight.
- Adjust stroke indicator position to indicate closed position when valve is closed.

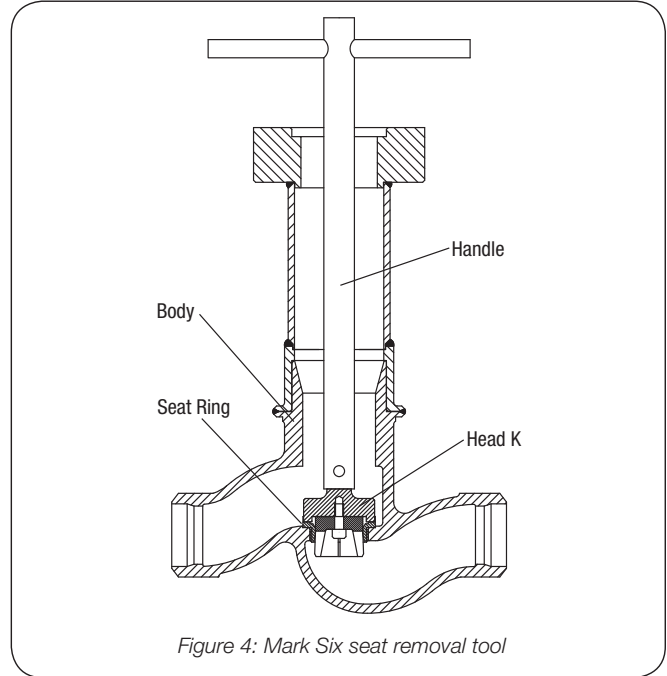

Figure 4: Mark Six seat removal tool

Removing the actuator, including yoke (without disassembling the valve body subassembly)

- Fully retract the plug until the stroke indicator is pointing to the open position.
- Loosen the stem clamp.
- Loosen the gland flange.
- Remove the yoke clamp (or yoke bolts if used).
- Turn actuator completely off the plug and bonnet.

CAUTION: Do not allow the plug stem to rotate. Flats are machined on the stem so it can be held with a wrench. Large actuators may require a hoist. If a lifting ring is not provided, use lifting straps around the yoke legs.

Reassembling the actuator, including yoke

- Lift the plug off the seat and turn the actuator onto the plug. On air-to-open valves, screw the actuator stem onto the plug stem as far as it will go. On air-to-close valves, leave two or three threads exposed.
- CAUTION:** Do not allow the plug to turn on the seat at any time. Do not turn the plug in the bonnet. Flats are machined on the plug stem so it can be held with a wrench.
- Assemble yoke clamp or tighten yoke bolts.
- Adjust the stem engagement for air-to-open valves only, according to the procedure outlined in the "Reassembly of the Mark Six" instructions, step 11.
- Cycle the valve to closed position.
- Slide the stem clamp on the actuator so that the bottom of the stem clamp is flush with the bottom of the actuator stem. Check to make sure the slits in the actuator stem are perpendicular to the stem clamp bolting.
- Tighten the stem clamp.
- Tighten the gland flange nuts evenly to slightly over finger-tight.

Troubleshooting

Failure	Probable Cause	Corrective Action
Stem motion impeded	<ol style="list-style-type: none"> 1. Overtightened packing 2. Service temperature is beyond operating limits of trim design 3. Inadequate air supply 4. Stem frozen at upper packing 5. Malfunctioning positioner 	<ol style="list-style-type: none"> 1. Adjust packing box nuts to slightly over finger-tight. 2. Reconfirm service conditions and contact factory. 3. Check for leaks in air supply or instrument signal system; tighten loose connections and replace leaky lines. 4. Temperature around packing should be increased or a longer extension may be required. 5. Refer to positioner maintenance instructions.
Excessive leakage	<ol style="list-style-type: none"> 1. Improperly tightened bonnet flange bolting 2. Worn or damaged seat ring 3. Worn or damaged seat or bonnet gasket 4. Inadequate actuator thrust 5. Incorrectly adjusted plug 6. Improper flow direction 7. Improper handwheel adjustment acting as a limit-stop 	<ol style="list-style-type: none"> 1. Refer to step 3 of "Reassembling the Body" section for correct tightening procedure. 2. Disassemble valve and replace or repair seat ring. 3. Disassemble and replace gaskets. 4. Check for adequate air supply to actuator; if air supply is adequate, reconfirm service conditions and contact factory. 5. Refer to steps 8–10 of "Reassembling the Body" section for correct plug adjustment. 6. Refer to original specifications or contact factory. 7. Adjust handwheel until plug seats properly.
Inadequate flow	<ol style="list-style-type: none"> 1. Improper plug adjustment, limiting stroke 2. Malfunctioning positioner 3. Service conditions exceed trim design capacity 	<ol style="list-style-type: none"> 1. Refer to steps 8–10 of "Reassembling the Body" section for correct plug adjustment. 2. Refer to positioner maintenance instructions. 3. Verify service conditions and consult factory.
Plug slams	<ol style="list-style-type: none"> 1. Incorrect plug adjustment allowing improper cushion of air between actuator piston and yoke 2. Inadequate air supply 3. Trim sized too large for flow rate 	<ol style="list-style-type: none"> 1. Refer to steps 8–10 of "Reassembling the Body" section for correct plug adjustment. 2. Check air supply to actuator; repair leaks and remove any restrictions in supply line. 3. Install reduced trim.
Valve does not fail in correct position	<ol style="list-style-type: none"> 1. Incorrect flow direction 	<ol style="list-style-type: none"> 1. Reconfirm direction and, if necessary, correct flow direction through valve.



USA

Flowserve Flow Control Division
1350 N. Mountain Springs Parkway
Springville, UT 84663
USA
Phone: +1 801 489 8611
Fax: +1 801 489 3719

Austria

Flowserve Control Valves GmbH
Kasernengasse 6
9500 Villach
AUSTRIA
Phone: +43 (0) 4242 41181 – 0
Fax: +43 (0) 4242 41181 – 50

India

Flowserve India Controls Pvt Ltd.
Plot # 4, 1A, Road #8 EPIP
Whitefield Bangalore, Karnataka, 560066
INDIA
Phone: +91 80 40146200
Fax: +91 80 28410286

China

Flowserve Fluid Motion and
Control (Suzhou) Co., Ltd.
No. 35, Baiyu Road
Suzhou Industrial Park
Suzhou Jiangsu Province
P.R. 215021
CHINA
Phone: +(86 512) 6288 8790
Fax: +(86 512) 6288 8736

Singapore

Flowserve Pte. Ltd.
12 Tuas Avenue 20
Singapore 638824
REPUBLIC of SINGAPORE
Phone: +65 6879 8900
Fax: +65 6862 4940

Saudi Arabia

Flowserve Abahsain Flow Control Co., Ltd.
Makkah Road, Phase 4
Plot 10 & 12, 2nd Industrial City
Dammam
KINGDOM of SAUDI ARABIA
Phone: +966-3-857 3150
Fax: +966-3-857 4243

United Arab Emirates

Flowserve Gulf FZE
Building S 10112, South Zone One
Jebel Ali Freezone
P.O. Box 17678
Dubai
UNITED ARAB EMIRATES
Phone: +971 4 8153300
Fax: +971 4 8807190

Flowserve Corporation
5215 North O'Connor Blvd.
Suite 2300
Irving, Texas 75039-5421 USA
Telephone: +1 937 890 5839

Flowserve Corporation has established industry leadership in the design and manufacture of its products. When properly selected, this Flowserve product is designed to perform its intended function safely during its useful life. However, the purchaser or user of Flowserve products should be aware that Flowserve products might be used in numerous applications under a wide variety of industrial service conditions. Although Flowserve can provide general guidelines, it cannot provide specific data and warnings for all possible applications. The purchaser/user must therefore assume the ultimate responsibility for the proper sizing and selection, installation, operation, and maintenance of Flowserve products. The purchaser/user should read and understand the Installation Instructions included with the product, and train its employees and contractors in the safe use of Flowserve products in connection with the specific application.

While the information and specifications contained in this literature are believed to be accurate, they are supplied for informative purposes only and should not be considered certified or as a guarantee of satisfactory results by reliance thereon. Nothing contained herein is to be construed as a warranty or guarantee, express or implied, regarding any matter with respect to this product. Because Flowserve is continually improving and upgrading its product design, the specifications, dimensions and information contained herein are subject to change without notice. Should any question arise concerning these provisions, the purchaser/user should contact Flowserve Corporation at any one of its worldwide operations or offices.

©2019 Flowserve Corporation. All rights reserved. This document contains registered and unregistered trademarks of Flowserve Corporation. Other company, product, or service names may be trademarks or service marks of their respective companies.

VLENIM0006-03 (AQ) July 2019