



Edward Valves

Edward Valves

*Maintenance Manual for Edward
Equiwedge™ Gate Valves*

V-378 R1

Table of Contents

Introduction and Scope	3	Disassembly Procedure for Equiwedge Gate Valves.....	13	TABLES	
Gate Valve Figure Numbers.....	3	Disassembly Procedure for Bonnet Types, Area 3		Table 1	Gland Bolt Torques.....
Description of Equiwedge Gate Valve Types.....	4	Type I.....	14	Table 2	Bonnet/Cover Bolt/ Nut Pull-up Torques.....
Type I.....	4	Type II.....	15	Table 3	Welding Rod Recommendations
Type II.....	4-5	Type III.....	16	Table 4	Dimensions for Bearing Preload Washer.....
Type III.....	5	Type IV & V.....	17	Table 5	Bearing Retainer Preload Torque
Type IV.....	5	Reassembly Procedures for Equiwedge Gate Valves	18	Table 5A
Type V.....	5	Exploded View	19	Table 6	Bearing Retainer Final Torque
Service Problems	6	Reassembly Instructions.....	20	Table 6A
Packing Chamber Leak.....	6	Handwheel Actuated Valves.....	20	Table 7	Composite Gasket Bonnet/Cover Bolt/Nut Pull-Up Torques
Packing Recommendations.....	6	Tapered Roller Bearing Preload Instructions	21		
Pressure Seal Gasket Leak	7	Reassembly Instructions for Valves with Composite Pressure Seal Gaskets Only	23		
Pressure Seal Leak	7	Type I Reassembly.....	24		
Gate and Seat Leakage.....	8	Type II Reassembly.....	25		
Body or Bonnet Wall Leak	8	Type III Reassembly.....	26		
Lubrication	8	Type IV & V Reassembly	26		
Repair Procedures.....	9	Appendix A			
Valve Body Repairs.– Body Bore Gasket Seal Area Repairs	9	Procedure for Removing Manual & Electric Actuators	28-29		
Body Wall Repairs	10	Appendix B			
Body Guide Repairs.....	10	Valve Tools Available for Rental.....	30		
Seat Repairs.....	10	Terms and Conditions.....	31		
Gate Repairs.....	11	Contact Information	32		
Bonnet Repairs	11				
Backseat	11				
Porosity in Bonnet	12				
Stem Repairs	12				
Field Repair Equipment.....	12				

Introduction and Scope

Introduction

This manual has been prepared to serve as a guide for maintenance of Edward Equiwedge gate valves, all of which feature the pressure seal bonnet joint construction. Although rigid metallurgical, non-destructive examination, physical and visual inspection is standard procedure for Edward Valves products, it is inevitable that some valves, after a period of time, will require repairs. This manual will assist you in restoring the valve to good working condition with a minimum of time and expense.

Scope

Before starting any repairs, it will be helpful to have some understanding of the valve's physical construction. Consequently, the five basic types of pressure seal construction are discussed and illustrated first. All Equiwedge gate valves employ one of these five basic types.

The next major section of this manual discusses the more common service problems, and explains the reason for certain failures. The reason for the problem should be understood before work is actually started.

Then, the procedure to be followed in making the repair is explained. This section includes normal valve maintenance as well as major valve repairs. Field repair equipment available from Edward Valves is described and illustrated. Valve lubrication

and welding rod recommendations are also included. These procedures should be adequate for almost any Equiwedge gate valve repair or maintenance problem that may arise.

Following is a section describing the disassembly procedure for the various valve components; for example, manual handwheel, manual geared actuators or electric actuators, valve yokes, and the five basic bonnet types. It is very important that this manual be studied before any disassembly work is done to avoid needless work and loss of time by selecting the improper procedures.

The last sections include reassembly instructions and available maintenance equipment and information on the various types of actuators, both manual and electrical.

Gate Valve Figure Numbers Described in this Manual

Figure No.	Class	Pressure Seal Type	Size
1611-1611Y	600	I & II	2½ to 28
1711Y	Special Class 600	I & II	2½ to 28
1911-1911Y	900	III, IV, & V	2½ to 28
14311Y	Special Class 900	III, IV, & V	2½ to 28
11511-11511Y	1500	III, IV, & V	2½ to 24
12011Y	Special Class 1500	III, IV, & V	2½ to 24
12511-12511Y	2500	III, IV, & V	2½ to 24
14411Y	Special Class 2500	III, IV, & V	2½ to 24

Description of Equiwedge Gate Valve Types

Type I is a flanged yoke design with a separate gasket retainer ring, both of which are held to the body by cap screws. The bonnet retainer is screwed onto the bonnet and cap screws are screwed down on top of the body to force the bonnet into contact with the gasket. See *illustration No. 1*.

Type II is a flanged yoke design with or without a separate bonnet retainer ring, both of which are held on the body by cap screws or studs and nuts. The bonnet is pulled up into contact with the gasket with studs and hex nuts. See *illustrations Nos. 2A and 2B, pgs. 4 and 5*.

Type III is a wishbone yoke design bolted to the body. It has a segmental retaining ring, spacer ring and a screwed on bonnet retainer equipped with push down bolts to pull the bonnet up into contact with the gasket. See *illustration No. 3, pg. 5*.

Type IV is a wishbone yoke designed bolted to the body. It has a segmental retaining ring, spacer ring and separate bonnet retainer with pull up studs screwed into the bonnet to contact the gasket. See *illustration No.4, pg. 5*.

Type V has a yoke lock ring connection to the body with a segmented ring, gasket retainer and a separate bonnet retainer with studs screwed into the bonnet to pull up the bonnet against the gasket. See *illustration No. 5, pg. 5*.

Valve Type I

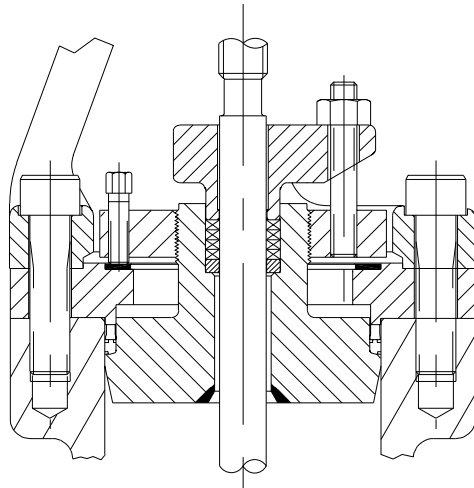

Illustration No. 1

Size 2-1/2 & 3 - Figure 1611 and 1611Y
Size 2-1/2 & 3 - Figure 1711Y

Valve Type IIA

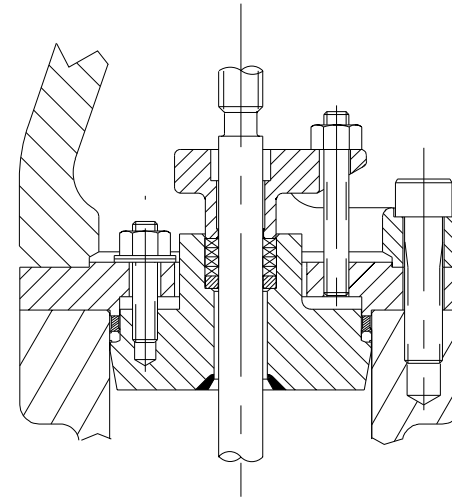

Illustration No. 2A

Size 4" - Figure 1611 and 1611Y
Size 4" - Figure 1711Y

Description of Equiwedge Gate Valve Types (cont.)

Valve Type IIB

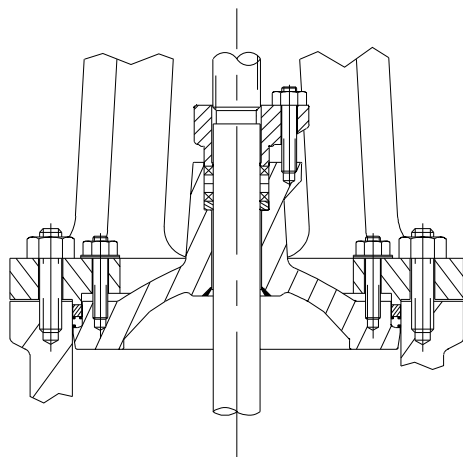

Illustration No. 2B

Size 6 - 28 - Figure 1611 and 1611Y

Size 6 - 28 - Figure 1711Y

NOTE: Size 6 and 8 valves are wishbone yoke design with flange.

Valve Type III

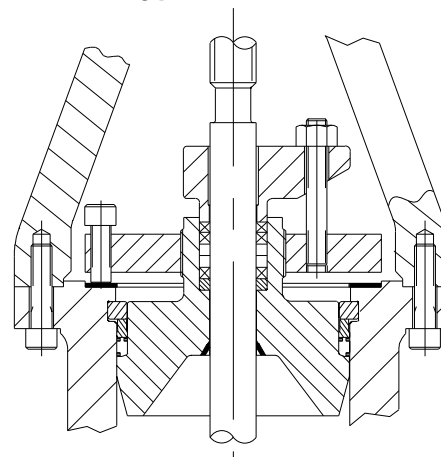

Illustration No. 3

Size 2-1/2 - 3 - Figure 1911-1911Y-14311Y

Size 2-1/2 - 3 - Figure 11511-11511Y-12011Y

Size 2-1/2 - 3 - Figure 12511-12511Y-14411Y

Valve Type IV

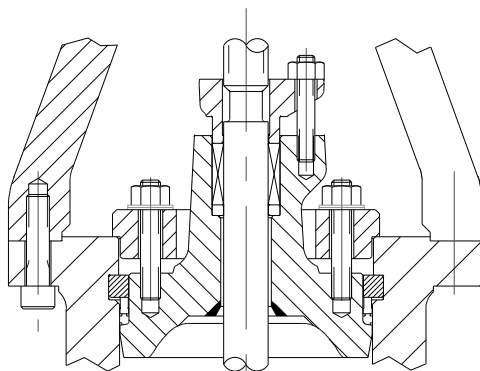

Illustration No. 4

Size 4 - 8 - Figure 1911-1911Y-14311Y

Size 4 - 8 - Figure 11511-11511Y-12011Y

Size 4 - 8 - Figure 12511-12511Y-14411Y

Valve Type V

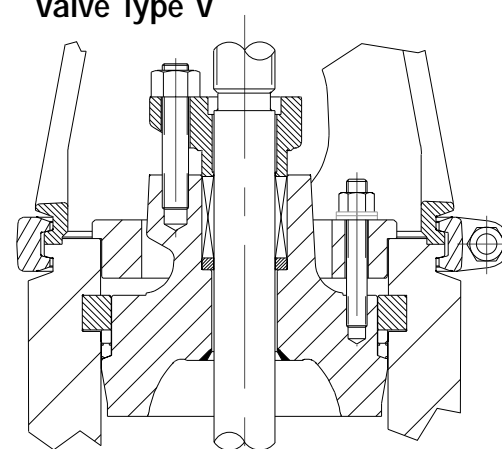

Illustration No. 5

Size 10 - 28 - Figure 1911-1911Y-14311Y

Size 10 - 24 - Figure 11511-11511Y-12011Y

Size 10 - 24 - Figure 12511-12511Y-14411Y

Service Problems

Packing Chamber Leak

Where moisture appears or actual dripping occurs at the packing chamber around the stem, gland or gland flange which cannot be eliminated by re-torquing the gland bolt the following points should be considered.

1. The packing may have become hard. Replace the packing.
2. Gland travel has been fully taken up. Repack with new packing.
3. The wrong packing is being used. See packing recommendations shown on this page.
4. A stem should be replaced when it has become deeply scratched, burred, or otherwise mutilated from careless handling, or where the stem has worn, tapered or has been bent.
5. The gaps in the rings of split packing have not been staggered around the stem. They should be inserted in this manner.
6. The packing gland may be binding against the packing chamber or stem and does not compress the packing properly. Make certain the gland fits the packing chamber and is tightened down equally on each side.

Packing Recommendations

Edward valves are packed with all-purpose with packing sets. This is a combination of packing using braided rings at the top and bottom in the packing chamber and flexible graphite packing in the center section. Packing gland should be tightened down enough to prevent leakage but not enough to develop excessive operating torque.

When the gland has advanced approximately half way into the packing chamber, it is recommended that additional packing rings be added. To obtain best results, the stem should be thoroughly cleaned. Replacement packing should be the same as that originally furnished.

We recommend that replacement packing be purchased from Edward Valves to assure packing with the proper density and corrosion inhibitors is always used.

IMPORTANT:

Long service life from modern graphitic packing requires that adequate preloads be applied when repacking.

1. All parts should be clean and not scored or pitted, especially the stem.
2. The valve internal parts and bonnet should be assembled prior to installing the packing.

3. Position split packing rings with the ends of adjacent rings rotated 90°.
4. Install in the following sequence:
 - Bottom Ring** – Braided Ring
 - Center Rings** – Die formed expanded graphite
 - Top Ring** – Braided Ring
5. Clean and lubricate the gland eye-bolts.
6. Carefully seat each individual packing ring before adding the next ring.
7. Apply the recommended torque to the gland nuts evenly without cocking the gland. See Table 1, pg. 7, for recommended torques.
8. Tighten the nuts to the initial values shown, then loosen and re-tighten to the final torque.
9. Stroke the valve, then re-check the gland nut torques.

Note: The torque values given are for sealing full rated pressure. For line pressures less than the full CWP rating of the valve, the final torques may be reduced by the ratio of P_{actual}/CWP down to a minimum of $P_{actual} = 1500$ psig. This will reduce packing drag and extend packing life.

Service Problems (cont.)

TABLE 1
GLAND BOLT TORQUES, FT-LBS
CLASS 300 & 600 VALVES

FIGURE NUMBERS	SIZE	INITIAL TORQUE	FINAL TORQUE
1611, 1611Y, 1711Y	2.5	26	8
	3	26	8
	4	26	8
	6	29	8
	8	44	13
	10	67	19
	12	72	21
	14	76	22
	16	95	27
	18	121	35
	20	127	37
	24	156	45
28	221	64	
1911, 1911Y, 14311Y	2.5	26	11
	3	26	11
	4	26	11
	6	44	19
	8	64	28
	10	72	31
	12	107	46
	14	151	65
	16	159	69
	18	167	72
	20	208	90
	24	193	84
11511, 11511Y, 12011Y	2.5	26	19
	3	26	11
	4	29	21
	6	48	35
	8	90	65
	10	151	109
	12	223	161
	14	242	175
	16	343	247
	18	353	255
	20	378	273
	24	268	193
12511, 12511Y, 14411Y	2.5	26	26
	3	26	26
	4	29	29
	6	101	101
	8	133	133
	10	155	155
	12	311	311
	14	199	199
	16	442	442
	18	311	311
	20	503	503
	22	663	663
24	806	806	

Pressure Seal Gasket Leak

Edward valves have been produced with two types of pressure seal gasket: Earlier valves had metal gaskets, while later designs have composite expanded graphite gaskets. The valves with composite gaskets can be identified by a "B" prefix on the figure number. Assembly and disassembly of the two gasket types are essentially the same except the composite gasket designs have Belleville spring washers under the nuts (or capscrews) of the pull-up bolting, and the tightening torque requirements for the pull-up bolting are different.

To guard against leakage, the bolts should be kept tightened at all times.

A torque wrench should be used for tightening the bonnet or cover retainer stud nuts or capscrews which are used to pre-load the pressure seal gasket.

All nuts/capscrews should be tightened in an alternating star pattern to insure even tightening.

The bolting should be tightened to the torque values shown in Table 2 while the valve is under full line pressure.

Pressure Seal Leak

Should the leak fail to stop after tightening, it must be concluded that there is an imperfect pressure seal, and the valve will have to be opened for examination.

(Note: Regardless of the cause of failure, opened pressure-seal bonnets should always be reassembled with a new gasket. These are available from stock via Air Express from Raleigh, North Carolina.) Such a leak may result from any of the following causes:

- 1. Incomplete Seal Between Bonnet and Gasket.** An incomplete seal around the gasket seating surface of the bonnet (or cover on check valves) may be caused by corrosion, dirt, chips, or other foreign matter on the mating surfaces of the sealing angle.
- 2. Incomplete Seal Between Body I.D. and Gasket.** An incomplete seal in the

TABLE 2
BONNET/COVER BOLT/NUT PULL-UP
TORQUES
(WITH VALVE UNDER PRESSURE)

BOLT SIZE	REQUIRED TORQUE, FT-LBS	
	METAL GASKET	COMPOSITE GASKET
3/8	18	5
7/16	30	5
1/2	45	7
9/16	68	10
5/8	90	15
3/4	150	25
7/8	240	35
1	370	55
1 1/8	533	80
1 1/4	750	110
1 3/8	1020	150
1 1/2	1200	170
1 5/8	1650	230
1 3/4	2250	320
1 7/8	3000	420
2	3300	460

Service Problems (cont.)

area of the gasket and body I.D. contact may be caused by surface imperfections in the body wall in the form of pin holes, extended cracks, or indentations where the metal has failed sometime after valve installation and use. Such imperfections may be surface indications deeper flaws in the body casting which may cause a by-pass around the pressure seal.

Gate and Seat Leakage

A leak existing at the seat and gate of a properly closed valve might be indicated by one of the following: a definite pressure loss in the high pressure side of the valve; continued flow through an inspection drain on the low pressure side; or, in hot lines, a downstream pipe that remains hot beyond the usual length of time and conductivity range. First, try opening the valve slightly to flush any foreign material from the seating surfaces and then fully close the valve. If this doesn't stop the leakage, then one or more of the following may be the cause:

1. Foreign material has been imbedded into the seating surfaces preventing a seal.
2. Foreign material has scratched or cut the seating surface.
3. An obstruction such as a tool or other

foreign material has been lodged across or between the seats and preventing the gate from closing.

4. The valve seat has been steam or water cut by not fully closing the valve during a previous operation.

If the valve cannot be isolated and repaired as soon as possible, schedule the work to be done at the next outage.

Body or Bonnet Wall Leak

This is a leak through the pressure containing parts of the valve. A leak occurring through the bonnet should be readily detectable because of the lack of insulation. On the body, because of the heavy insulation, a small leak may go unnoticed for a time on a hot line because the piping evaporates the leakage.

Lubrication

In order to obtain long service life and maximum reliability, valves require periodic lubrication of the bearings and stem threads the same as for any machinery with rotating parts.

All handwheel actuated Equiwedge gate valves are equipped with low friction bearings, needle bearings in the smaller sizes and tapered roller bearings in the larger sizes. These valves have a lube fitting for convenient relubrication. Both the stem threads and the bearings can be relubed through this fitting. In addition, it is advisable to clean the stem first while in the open position and apply fresh grease to the threads, then repeat while in the closed position.

For valves that are operated infrequently, relubrication at least once a year is recommended. The recommended lubricant for both bearings and stem threads is Rycon EP 2, manufactured by the American Oil Company. This is an extreme pressure, temperature lubricant of high quality. Use of other lubricants should be avoided.

For valves that are operated frequently, the lubricant should be replenished at both the bearings and stem threads every three months or at shorter intervals depending on the severity of the service.

Repair Procedures

VALVE BODY REPAIRS

Body Bore Gasket Seal Area Repair

(Valves with metal gasket only)

Class 600 Equiwedge gate valves have the seal area for the pressure seal just below the top of the body bore. The seal surface is inlaid with 18-8 stainless steel on all valves size 16 and larger.

Class 900 and higher Equiwedge gate valves have the seal area just below the gasket retainer groove. The seal surface is inlaid with 18-8 stainless steel on all valves in these pressure classes.

The seal area, whether inlaid or not, must be smooth, round and without any appreciable taper. Upon normal disassembly of the valve the gasket may leave some vertical score marks when withdrawn.

If the depth of defects are .010" or less, the seal area can be honed using a portable Sunnen Hone. This device is adjustable for different bore sizes and can be operated by one man using a portable electric drill of 1/2" to 3/4" capacity. When the defects are greater than .010", welding will be required to cut down the repair time.

First make visual inspection all around this area, noting, if possible, where flaws may occur. Next wash the area with a suitable solvent, drying with clean rags and, if necessary, polishing with a fine grade of emery cloth to remove any undesirable scale or foreign matter which may be deposited on the area suspected of having flaws. Use a dye penetrant test if cracks are suspected.

Where it is necessary to repair the body inlay by welding, note the following:

1. Prior to any cutting or welding operations being performed on the valve, it is necessary that adequate seat joint protection be provided and some means of insurance against getting chips, weld spatter or other foreign matter into the pipe line if the valve is permanently mounted. A round piece of sheet metal placed in the bore down to the shoulder above the guide grooves and taped in place will protect the guide surfaces and seats.
2. Chip out the defective area in the body, being careful to remove the affected portion to its end, inside the casting, and to thoroughly clean it away.
3. With a small hand grinder, grind the chipped area smooth.
4. Preheat an area large enough around the imperfection so that during the entire welding operation heat will be retained at approximately 400 degrees Fahrenheit.
5. Use a stainless steel inlay selected from either 18-8 stainless steel rod, Harstain 18-8, Stainweld "K" 18-3, Stainweld 18-8 or equivalent.
6. Lay the weld in thin, even layers, peening each layer before proceeding with the next, and being careful to maintain a temperature above 400 degrees Fahrenheit in the area being repaired. Peening the bead

actually stretches it and counteracts its tendency to contract and shrink as it cools. The last layer of weld must overlap onto the sound metal to insure a weld without an undercut at the edges. The overlapping should be done along this edge by using a welding rod of 1/8" maximum diameter. The last layer should bring the height of the welded area up to 1/16" above the original surface, as checked with a straight edge along the body bore.

For this type of weld repair, it is recommended that the last layer be pounded while still hot with the flat face of the hammer. Thermal stress relieving is not recommended.

With a hand grinder, rough grind the welded surface to within about .010" of the finished surface. A simple template cut from thin sheet metal and having the same arc as the body bore diameter, and straight edge laid along the body bore can be used as a guide. A final cut then can be made, using a fixture similar to the one shown in *Illustration No. 9, pg. 15*. Final finishing can be done with the adjustable Sunnen hone described on this page.

After removing all the dirt, chips, slag, spatter, and grinding dust from the body, the bore should be polished with fine emery cloth and then thoroughly cleaned before reassembly of the valve.

Repair Procedures (cont.)

It is best that a new pressure-seal gasket be used upon reassembly.

Body Wall Repairs

There are five basic steps in repairing a casting defect:

1. Cut out to sound metal. Attempting to weld over the defect will only leave a notch that may re-introduce the defect. Cutting may be done by chipping, grinding or flame gouging. The amount of metal removed should be held to a minimum to avoid distortion during subsequent welding.
2. Preheat, using the minimum temperature specified by the material specification and/or the design code. Use at least 400F on WC9 or C5 material, 300F on WC6. Although cast carbon steels such as WCB or WCC do not require preheat, it may be advantageous to remove any moisture or other contaminants from the area to be welded. This may also identify any leak paths. There are also disadvantages to preheat, especially localized preheat, that must be considered when working in areas of the casting with finish machined dimensions. Distortion may result in more damaging problems than those concerns created by the original defect. Lower preheats and the control of inter-pass temperature are two methods used to minimize distortion.
3. Welding should be done by qualified welders, using qualified procedures and weld material of a chemistry matching the casting (see Table 3 for welding rod recommendations). The final weld

TABLE 3 – WELDING ROD RECOMMENDATIONS

MATERIAL TO BE WELDED			WELD ROD RECOMMENDATIONS
ASME IX P-Numbers	Material	ASTM Grade	AWS Classification
P-1	Carbon Steel	1. ASTM A216, Grade WCB 2. ASTM A105	AWS 5.1 E7018
P-4	1-1/4% Chromium, 1/2% Molybdenum Low Alloy Steel	1. ASTM A217, Grade WC6 2. ASTM A182, Grade F11	AWS 5.5 E8018-B2
P-5	2-1/4 Chromium, 1% Molybdenum Low-Alloy Steel	1. ASTM A217, Grade WC9 2. ASTM A182, Grade F22	AWS 5.5 E9018-B3
P-8	18% Chromium, 8% Nickel Stainless Steel	1. ASTM A351, Grade CF8M 2. ASTM A182, Grade F316	AWS 5.4 E316
P-8	18% Chromium, 8% Nickel Stainless Steel	1. ASTM A351, Grade CF8C 2. ASTM A182, Grade F347	AWS 5.4 E347

WELDING EDWARD VALVES IN-LINE

When welding a valve in line, the installer should apply the specific technical rules imposed by the jurisdictional authority of the area where the valve is installed. In the absence of such rules, following are suggested practices for welding Edward Valves in line:

1. Welding should be done using procedures and personnel qualified in accordance with ASME Section IX. Rules for preheat and postheat are stated in Chapter V of ASME B31.1 (Power Piping).
2. The valve should be welded in line, one end at a time, in a closed position (approximately a half-turn after the seat in

the body comes in contact with the disk). This is suggested to preclude warpage between seating surfaces caused by temperature induced stresses during welding or subsequent heat treat. It also protects the seat from weld spatter that might coat the lapped seat and disk. When postweld heat treat is required, each weld end should be heat treated one at a time, to minimize impact of heat on valve internals. Do not heat treat an Edward Valve with a piping attached as a unit in a furnace, as warpage of parts may occur. After welding, open the valve and flush the line to clean out all foreign matter.

Repair Procedures (cont.)

should be blended into the contour of the casting.

- Stress relieving is generally recommended. Decisions to not stress relieve should factor in piping code rules. The temperatures must be based on material specification and piping code recommendations. Again, since temperatures are much higher than those experienced in welding, there are also disadvantages that must be considered. Distortion may result in more damaging problems. Lower temperature postweld heat treatment is sometimes an option for carbon steels.
- The final weld should receive any needed nondestructive testing. This should include a visual examination and liquid penetrant or magnetic particle examination. Some major weld repairs could even mandate radiography to ensure a sound weld.

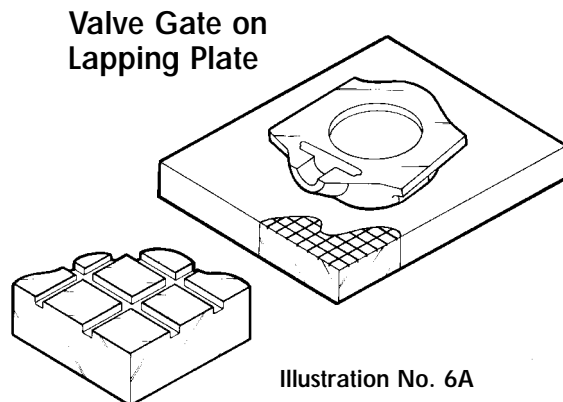

Illustration No. 6A

Body Guide Repairs

The body guide grooves guide the gate through about 95% of the valve stroke and allow only 5% of the valve stroke to thrust against the seating surfaces. It is important that the side faces of the groove be smooth and free of gouges and burrs. A flat file can be used to remove any burrs and raised edges.

Seat Repairs

The seats in a gate valve may require repair when the seating surfaces allow fluid to pass. This may be due to erosion of the surfaces caused by not closing the valve tightly or seating on foreign material. Verification of such conditions may be obtained by a seat blueing test or by close visual examination.

To correct these conditions seat refinishing will be necessary. A Dexter gate valve refinishing fixture will speed up repairs. See Appendix B for a discussion on use of the Dexter equipment.

Gate Repairs

Gate repairs to the seating surface can be done on a flat cast iron lapping plate. The lapping plate should be large enough so that the seating surface contacts the full diameter with sufficient additional surface allowing the gate to be pushed at least 1/3 of its diameter in any direction. Clover compound "A", Norton 320 mixed with olive or sperm oil, or for rough lapping, Carborundum H20 may be used. See illustration No. 6A.

Gate guide repairs can be done by rubbing the surface with a square steel block wrapped with emery cloth.

Bonnet Repairs

The valve bonnet provides several functions as follows: closure of the pressure vessel, a packing chamber to seal the stem, a back-seat area sealed with the stem so the valve can be repacked under pressure, and a sealing arrangement to prevent leakage to the atmosphere.

Equiwedge gate valves with metal pressure seal gaskets have a number of different angles machined on the bonnet to accommodate the pressure seal gasket. *These angles are shown in illustration No. 6B.*

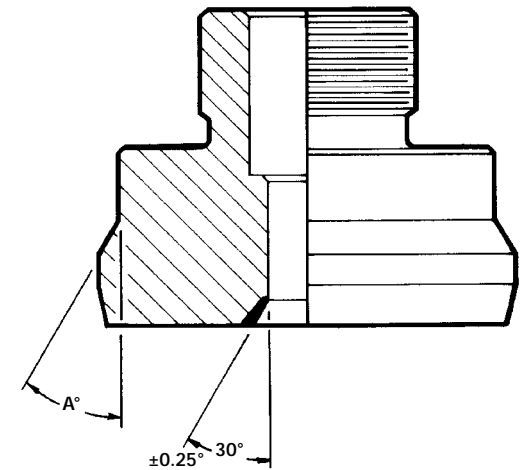

Pressure Seal Bonnet Angles
(Valves with metal gasket only)

Illustration No. 6B

	Class 600	Class 900	Class 1500	Class 2500
A	25° +0.5° -0.0°	35° +0.5° -0.0°	35° +0.5° -0.0°	45° +0.5° -0.0°

Repair Procedures *(cont.)*

If the gasket sealing surface of the bonnet has been damaged by corrosion, erosion or careless handling, this surface can be machined in a lathe. Chuck the bonnet, indicate true the large diameter and the bottom face before cutting the angle. The angle should be generated using a high speed or carbide cutting tool. Remove as little stock as possible to clean up. The surface finish should be held to 63 micro inch (**1.6 micrometer**) or better.

Backseat

The backseating surface is inlaid with hardfacing. Any machining on this surface must be done with carbide tools. The included angle of the backseat is 60° and the tolerance on the half angle is $\pm 0.25^\circ$. The surface finish should be held to 63 micro inch (**1.6 micrometer**) or better. Machining of this surface can be done in the same setup as machining the pressure seal angle. Once again the angle should be generated using a carbide cutting tool.

Porosity in Bonnet

In most gate valve sizes and pressure classes, the bonnet is made from a steel casting. Steel castings are subject to various types of defects such as shrinkage or porosity. Weld repair any defect in the bonnet wall the same as a body. If extensive repairs are required, remachining of the packing chamber, backseat, and pressure seal angle may be required because of distortion of these surfaces.

Stem Repairs

The basic function of a valve stem is to actuate the valve open or closed. Because it penetrates a pressure boundary, it must provide a diameter for the packing to seal leakage to the atmosphere and provide a seal in the fully open or backseated position so that packing may be replaced under pressure. Stems are made of high quality martensitic stainless steel or other stainless alloy and hardened to withstand the high stresses. Welding is not recommended. Only cosmetic repairs to the packing diameter and machining of the backseat should be attempted. The angle on the backseat of the stem is $28^\circ - 0.50^\circ + 0.25^\circ$. First contact is made at the top of the conical surface. Valve stems must be concentric and free from score marks on the packing diameter and backseat area to perform the functions listed above. When a stem is bent or deeply scored on the packing diameter, it should be replaced.

Field Repair Equipment

Available from the Edward Valves plant at Raleigh, North Carolina are some basic tools for repairing valves in the field. This equipment was developed for customer use on a rental basis. Contact your local Edward Valves sales representative for more information. A partial list of this equipment follows:

1. Four sizes of Dexter seat refinishing machines complete with refinishing plates for valve sizes 2-1/2 thru 28. *(See Appendix B, pg. 30)*
2. Two sizes of portable boring machines capable of reboring the pressure seal area in body on valves size 10 and larger. *(See Appendix B, pg. 30)*

Disassembly Procedure for Equiwedge Gate Valves

Introduction

Step-by-step disassembly procedures are described below for all types of Equiwedge pressure seal gate valves, including those with manual and motor actuators. **It is important that the following instructions be read and understood before any specific disassembly work is attempted.**

First determine the problem area. Maintenance problems can be divided into three major areas, and the area involved will affect the disassembly procedure. These areas, in general, are:

Area 1 The handwheel, or a manual or electric motor actuator.

Area 2 The yoke assembly including the yoke, yoke bushing, and bearings.

Area 3 The valve internals including the bonnet, body, pressure seal gasket, stem, gate, and seats.

If the problem is in Area 1, usually a manual or electric actuator will be involved and not a handwheel; see *Appendix A, pg. 29*.

If the problem is in Area 2, it will be necessary to remove the valve actuator only if the valve is handwheel actuated or has a **torque-only** manual or electric actuator. See procedure on pgs. 28 and 29 and select the proper one.

If the problem is in Area 3, two methods are available. In method 1 the yoke and actuator assembly may be removed from the valve body as a unit. This saves time, but requires adequate clearance. In method 2 the actuator and yoke are removed separately.

If problems are suspected to exist in any combination of Area 1, 2 or 3, then each of the respective procedures must be followed.

CAUTION

AS A GENERAL REMINDER, MAKE SURE ALL THE PRESSURE IS RELIEVED, BOTH UPSTREAM AND DOWNSTREAM AND IN THE CENTER CAVITY, BEFORE DISASSEMBLY WORK IS STARTED. Exceptions to this rule are noted below.

1. For service In Area 1

If pressure is to be maintained in the valve, backseat to full open position. The actuator, both manual or electrical, torque-only and torque and thrust types, may be removed. The blowout force on the stem due to pressure in the line will keep the stem on the backseat.

2. For service in Area 2

If pressure is to be maintained in the valve, the yoke may be removed on Types III, IV, and V. The blowout force on the stem due to pressure in the line will keep the stem on the backseat. **UNDER NO CIRCUMSTANCES SHOULD THE YOKE BE REMOVED ON TYPES I AND II WHILE UNDER PRESSURE.**

3. For service In Area 3

Close the valve fully and then open 1/8" (3mm). **SERVICE AREA 3 WITHOUT PRESSURE IN LINE.**

Disassembly Procedure of Bonnet Types Area 3

Type I Size
2-1/2 – 3
Class 600,
Figure
Numbers
1611, 1611Y
or 1711Y
Equiwedge
Gate Valves

Step-by-step disassembly instructions are described below for each of the five basic bonnet types. All of the following bonnet disassembly instructions are arranged in accordance with the general comments on pg. 13. Study these pages carefully before beginning. As disassembly progresses, place match marks on parts so that the same orientation can be maintained when reassembled.

Refer to illustration 7.

1. With the valve in the partially open position loosen the gland bolt nuts and tap the gland (this should relieve any pressure trapped in the valve).
2. Carefully loosen the yoke hex socket head cap screws. In case any trapped pressure remains in valve after step 1, it will now be relieved. Remove the yoke cap screws.
3. Loosen the bonnet hex socket head cap screws.
4. Remove the gland bolt nuts.
5. Rotate the bonnet retainer counter clockwise on the central bonnet thread. Close the valve, which when the gate contacts the seat, will raise the yoke about 1/2" (13mm). Pry up the gasket retainer and place three 3/8" (10mm) shims between the gasket retainer and the body at equal intervals. Now tighten the bonnet retainer cap screws in a star pattern to jack the pressure seal gasket out of

the body. Be careful not to cock the bonnet. This step may have to be repeated with thicker shims to finally break the gasket loose. See the note below.

6. Once the bonnet is loose, the yoke can be removed by turning the hand-wheel to close the valve. When the threads of the yoke bushing disengage, lift the yoke assembly over the stem and set on a clean plywood board or bed of clean rags.
7. The stem, bonnet, and gate assembly can now be removed, but **be careful to either clamp the gate halves or hold them securely** while withdrawing parts. See illustration No. 17 pg. 25. This is necessary because when the gate halves are disengaged from the guide grooves in the body, they can fall off the stem. Place the assembly on a bed of rags.

Note: These instructions have been sequenced for a valve in a horizontal pipeline with the stem in the vertical, up position. With a different stem orientation, the steps may have to be slightly modified. For example, in step 5 if the valves were in a horizontal pipe with the stem down when the gasket came free, all the parts would fall; so at least two of the yoke cap screws should be engaged into the body (at least three threads) to prevent this lack of control. This precaution should also be observed for other stem orientations.

Valve Type I

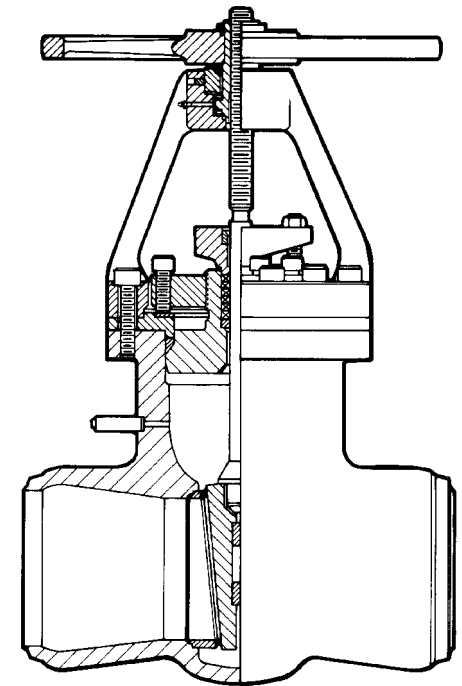

Illustration No. 7

Disassembly Procedure of Bonnet Types Area 3 *(cont.)*

**Type II Sizes
4 - 28 Class
600, Figure
Numbers
1611,1611Y
or 1711Y
Equiwedge
Gate Valves**

See illustrations 8 and 9.

1. With the valve in a partially open position remove the handwheel. The handwheel nut is locked in position with a small nylock set screw. This set screw must be loosened first before attempting to remove the handwheel nut. The handwheel is keyed to the yoke bushing. Remove the handwheel nut, handwheel and key and set aside.
2. Loosen the gland bolt nuts and tap the gland loose from the packing chamber. This should relieve any pressure that may be trapped in the valve.
3. Carefully loosen the yoke cap screws or hex nuts. In case any trapped pressure remains in the valve after step 2, it will not be relieved.

Valve Type IIA

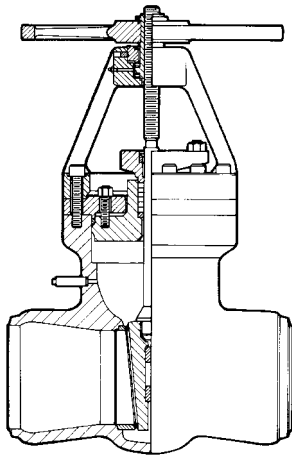

Illustration No. 8

Valve Type IIB

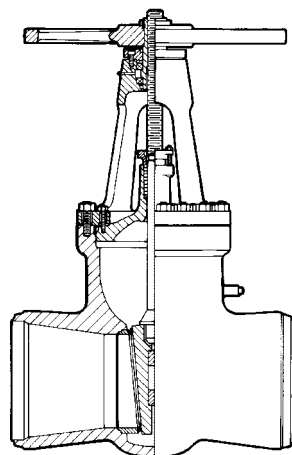

Illustration No. 9

4. Remove the gland bolt nuts.
5. Loosen the bonnet hex nuts about 3/8" (10mm) to 1/2" (13mm).
6. Close the valve, which when the gate contacts the seat, will raise the yoke. Place three or four shims 3/8" (10mm) to 1/2" (13mm) thick equally spaced between the yoke flange and the body. Now tighten the bonnet retainer hex nuts in a star pattern to jack the gasket out of the body. Be careful not to cock the bonnet. This step may have to be repeated with thicker shims to finally break the gasket loose. See Note this page.
7. Once the bonnet is loose the yoke can be removed. Remove the bonnet retainer hex nuts. Sling the yoke through the windows leaving space to turn the yokebushing and take up slack in a chain hoist. With a strap wrench around the top of the yoke bushing, close the valve, thereby raising the yoke. Keep a slight tension on the chain hoist so that the yoke bushing and stem threads are not damaged. Also, the pull point must be in line with the stem. Raise the yoke in this manner until the threads are disengaged, then lift away the yoke assembly. Set the yoke on a clean plywood board or bed of rags.
8. Valves with stems 1.62" (41.1 mm) to 2" (50.8mm) in diameter are threaded on the top end to accept a 1/2" – 13 eye bolt and those 2" (50.8mm) in diameter or over to accept a 3/4" – 10 eye bolt. Screw the eye bolt into the stem and attach a chain hoist. Lift the stem, bonnet, and gate out of the valve but be careful to clamp the gate halves securely while withdrawing the parts (see illustration No. 17 pg. 25). This is necessary because when the gate halves are disengaged from the body guide grooves, the halves and spacer ring can fall off the stem. Place the assembly on a bed of rags.

Note: These instructions have been sequenced for valve in a horizontal pipeline with the stem in the vertical, up position. With a different stem orientation, the steps may have to be slightly modified. For example, in step 3, if the valve were in a horizontal pipeline with the stem down, when the gasket breaks free in step 6, all the parts would fall; so, at least two of the yoke cap screws or hex nuts need to be partially engaged into/onto the body studs to prevent this. This precaution should also be observed for other stem orientations.

Disassembly Procedure of Bonnet Types Area 3 (cont.)

**Type III,
Sizes 2-1/2" - 3",
Classes 900,
1500, 2500
Figure Numbers
1911, 1911Y,
11511, 11511Y,
12511, 12511Y,
12011Y, 14311Y
or 14411Y**

See illustration No. 10.

1. With the valve in a partially open position, loosen the gland nuts and tap the gland to loosen engagement of the gland barrel with the packing chamber. This should relieve any pressure that may be trapped in the valve.
2. Loosen and remove the hex socket head cap screws fastening the yoke to the body. Close the valve and raise the yoke assembly off the body. Continue to close the valve until the stem threads are disengaged from the yoke bushing. Lift the yoke assembly over the stem and set it on a clean plywood board or a bed of rags.
3. Remove the gland nuts and gland and set the parts aside.
4. Loosen the hex socket head cap screws on the bonnet retainer. Unscrew the bonnet retainer from the bonnet and set aside.
5. Using a brass rod and hammer, drive the bonnet down into the body far enough to expose the gasket retainer segmented rings. Now drive the gasket retainer down to gain clearance for removal. The gasket retainer ring is split in three or four pieces; the shortest must be removed from the groove first, then the other two or three.
6. Place the bonnet retainer on top of the body and lift the stem-bonnet assembly up through the gasket and

spacer ring. Screw the bonnet retainer onto the bonnet until it is snug against the body. Tighten the bonnet retainer hex socket head cap screws in a star pattern against the body to jack out the gasket. Be careful not to cock the bonnet. This step may have to be repeated by loosening the hex socket head cap screws and by screwing the bonnet retainer down on the bonnet threads to a new position and then tightening the cap screws against the body until the gasket breaks free. See the note below.

7. The stem, bonnet, and gate assembly can now be removed but be careful to either clamp the gate halves together or hold them securely while withdrawing parts (see illustration No. 17, pg. 25). This is necessary because when the gate halves are disengaged from the guide grooves in the body, they can fall off the stem. Place the assembly on a bed of rags.

Note: These instructions have been sequenced for a valve in a horizontal pipeline with the stem in the vertical, up position. With a different stem orientation the steps will have to be slightly modified. For example, in step 6, if the valve were in a horizontal pipeline with the stem down when the gasket comes free, all parts would fall; some provision must be made to support the stem-bonnet assembly when the gasket breaks loose.

Valve Type III

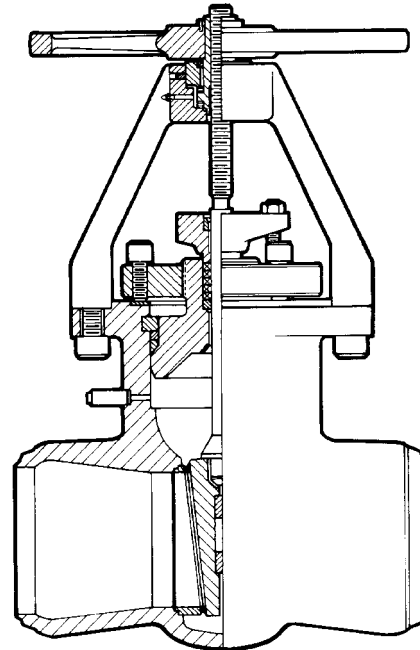

Illustration No. 10

Disassembly Procedure of Bonnet Types Area 3 (cont.)

**Type IV & V,
Sizes 4"-24,
Classes 900,
1500, 2500-
Figure numbers
1911,1911Y,
11511, 11511Y,
12511, 12511Y,
14311Y,
12011Y, or
14411Y**

See illustrations No. 11 and 12.

1. With the valve in a partially open position, loosen the gland nuts and tap the gland to loosen engagement of the gland barrel with the packing chamber. This should relieve any pressure that may be trapped in the valve.
2. The handwheel nut is locked in position with a small nylock set screw. Loosen the set screw then remove the handwheel nut. The handwheel is keyed to the yoke bushing so remove the handwheel and key and set them aside.
3. Loosen and remove the yoke cap screws or yoke lock ring bolts. If the valve is equipped with a yoke lock ring, it will be necessary to pry it off by using a cold chisel, tapping it into one of the splits to disengage the clamp rings.

Valve Type IV

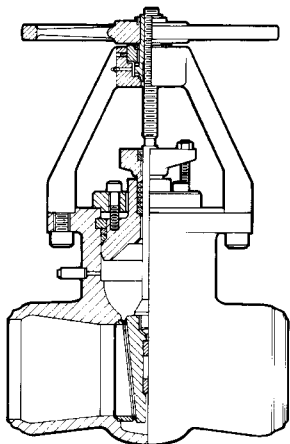

Illustration No. 11

Valve Type V

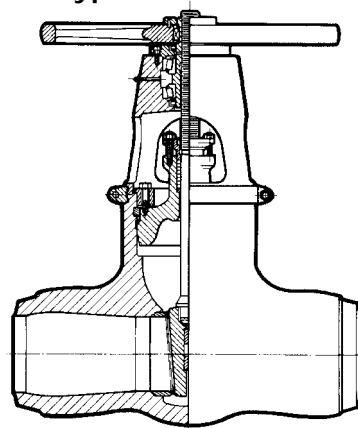

Illustration No. 12

4. Sling the yoke through opposite windows leaving space to turn the yoke bushing and take up slack in the chain hoist. With a strap wrench around the top of the yoke bushing, turn the valve to close. When the gates contact the seats, the yoke will rise. Continue turning until the yoke bushing threads are disengaged from the stem. Carefully lift the yoke over the stem and set aside on a plywood board or a bed of rags.
5. Remove the gland bolts and gland. Loosen and remove the bonnet retainer nuts and lift off the bonnet retainer. Set the parts aside.
6. Place an eyebolt in the threaded end of the stem. With a chain hoist mounted in line with the stem and fastened to the eyebolt, pull the stem firmly against the backseat. With clean rags and a vacuum, clean the top of the valve and exposed surfaces of the bonnet and gasket retainer segments.
7. Slack off the chain hoist and with a brass bar and hammer, and drive the bonnet down so that the gasket retainer segments are fully exposed.
8. Using the same tools, drive the gasket retainer segments down to the bottom of the groove (about 1/16" [2mm]) in the body.
9. Remove the gasket retainer segments and set them aside.
10. Place the bonnet retainer back on the body and with a chain hoist and lift the stem and bonnet so that the bonnet contacts the gasket. Screw nuts onto the bonnet studs and tighten in a star pattern to jack out the gasket. Be careful not to cock the bonnet.

Note: The stem should not be used to remove the pressure seal gasket.

11. When the bonnet assembly breaks loose, use a chain hoist to lift the assembly from the valve body, but be careful to clamp the gate halves securely before fully withdrawing the parts (see illustration No. 17, pg 25). This is necessary because when the gate halves are disengaged from the body guide grooves, the gate halves and spacer ring can fall off the stem. Place the assembly on a bed of rags.

Note: These instructions have been sequenced for a valve in a horizontal pipeline with the stem in the vertical, up position. With a different stem orientation the steps will have to be slightly modified. For example, in step 6, if the valve was in a horizontal pipeline with the stem down when the gasket comes free, all the parts would fall; some provision must be made to support the stem-bonnet assembly when the gasket breaks loose.

Reassembly Procedures for Equiwedge Gate Valves

Introduction

The reassembly procedures in this manual are not as detailed as the disassembly procedures since, in most cases, just the reverse procedure is used. However, step-by-step instructions are provided for each of the five bonnet types. In addition, the following general points should be considered:

1. The most important consideration in the reassembly of pressure seal valves is cleanliness. All flaky rust and dirt should be removed from all parts with a wire brush and emery cloth. Oil and grease should be removed with a suitable solvent to prevent any foreign material from collecting on the sealing and seating surfaces.

2. All threaded parts should be relubricated, such as cap screws, nuts, studs, and bonnet retainer threads, with a product such as "Never-Seez". The stem threads should be washed with solvent, dried, and a new application of high temperature EP (extreme pressure) grease applied to the threads. *See pg. 8 for recommendations.*
3. An important feature of Equiwedge gate valves is the two piece gate with a spacer ring between the two halves, *illustrated in figure 13A*. This spacer can be increased in thickness to compensate for material removed from the seats and gates by normal or extensive refinishing of these surfaces. This is a unique design feature. For every .005" (.13mm) (total) that

is removed from the seating surfaces, the gate seats lower in the body approximately 0.032" (.81mm). This amount of metal removal will not require any adjustment to the gate spacer ring thickness.

But, for example, if 0.050" (1.27mm) were removed from the combined seating surfaces, the gate will seat 0.312" (7.92mm) lower in the body and this wear can be compensated for by making a new spacer ring. In addition, the guide rails on each gate half will require grinding by half the amount added to the spacer ring to restore an adequate amount of clearance. The gate spacer ring material is stainless steel type 410 heat treated to 26 to 32 RC.

Stem-Gate Spacer Ring Assembly

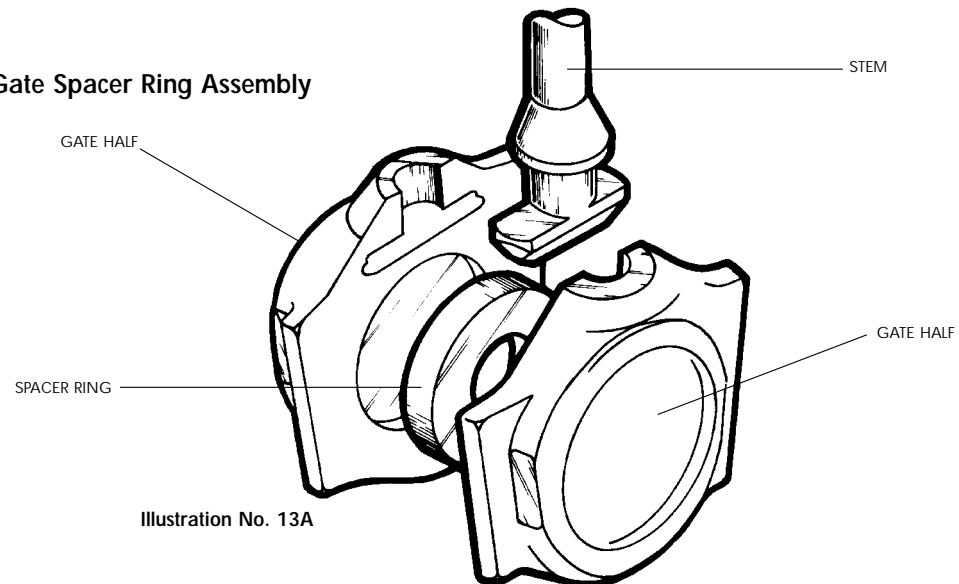

Illustration No. 13A

Exploded View

Typical Exploded View of Equiwedge Gate Valve

Part Names for Exploded View of Typical Equiwedge Gate Valves

1. Body
2. Test Nipple
3. Seat Ring
4. Gate
5. Gate Spacer Ring
6. Stem
7. Hex Nut
8. Yoke Lock Ring
9. Stud
10. Bonnet
11. Pressure Seal Gasket
12. Spacer Ring
13. Segmental Retaining Ring
14. Cap Screws
15. Bonnet Retainer Ring
16. Junk Ring
17. Gland Stud
18. Packing
19. Gland
20. Gland Bushing
21. Gland Nuts
22. Yoke
23. Grease Seal
24. Bearing
25. Key
26. Yoke Bushing
27. Bearing
28. Preload Shim Kit
29. Bearing Retainer
30. Grease Seal
31. Cap Screws
32. Handwheel
33. Handwheel Locknut
34. Set Screw

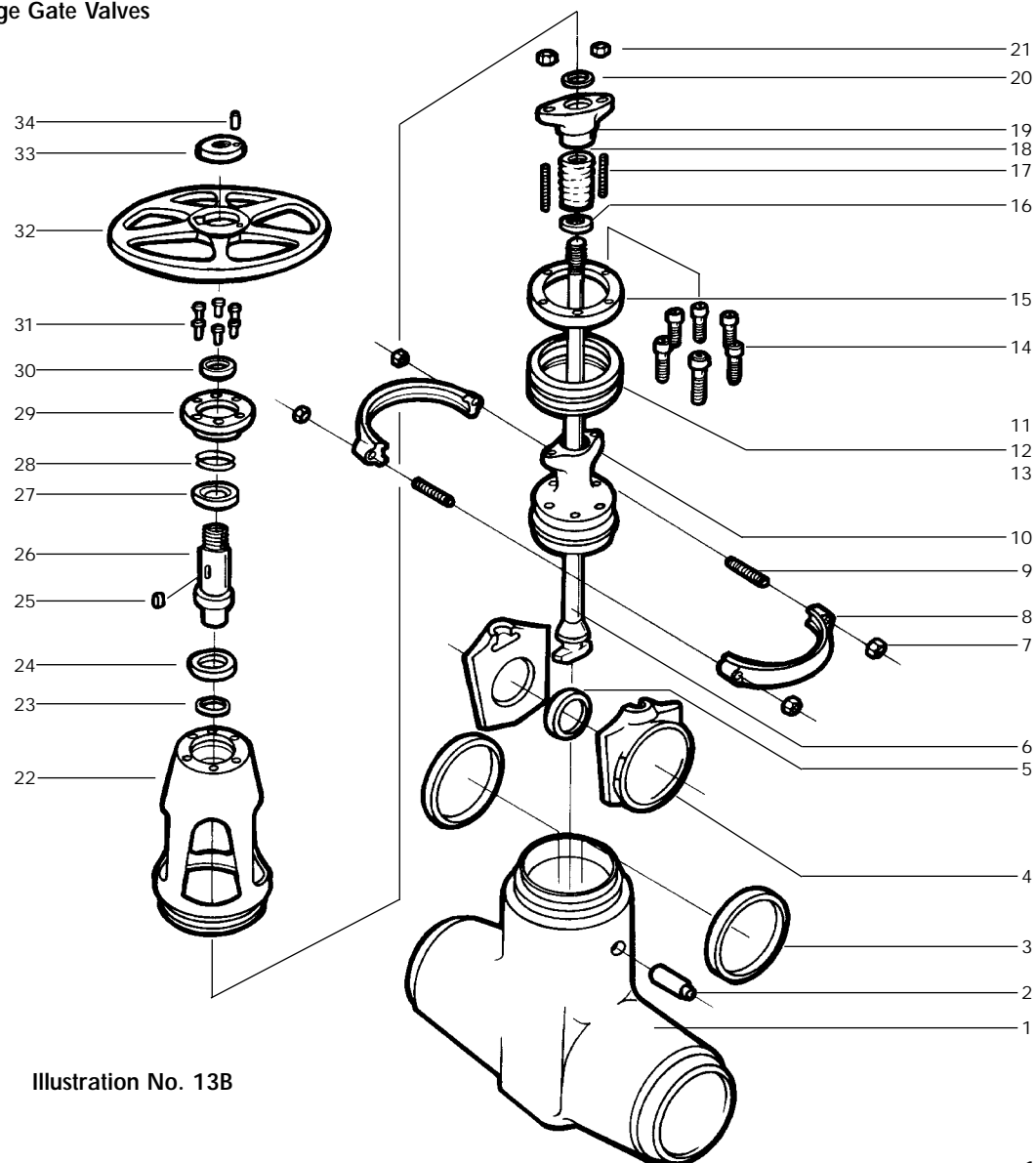

Illustration No. 13B

Reassembly Instructions

The yoke bushing threads should be cleaned in the same manner as the other threaded parts and regreased. The same lubricant should be used to regrease the yoke bushing bearings through the lube fitting. See pg. 8 for lubricant recommendations. Follow these guidelines:

1. Replace the stem packing.
2. Replace the pressure seal gasket with a new gasket.
3. Observe all match marks assigned during disassembly so that part orientation is maintained.
4. Reassemble stud nuts and cap screws using a torque wrench. See Table 2, pg. 7, for recommended torque values.
5. When reassembling the bearings in the yoke assembly, use the following procedure to obtain the proper clearance or preload.

Handwheel Actuated Valves

1. Equiwedge gate valves with stems 1-7/8" (47.6mm) diameter and smaller are equipped with needle bearings. See illustration No. 14. One bearing set is placed below the yoke bushing collar and one set above. All parts are retained by a screwed-in bearing retainer. This bearing retainer has spanner wrench holes on the top face for adjustment and is locked in place with a nylock set screw on the side of the yoke near the top.
2. The needle bearings **should not** have a preload. Rather, a slight amount of clearance is recommended. Tighten down the bearing retainer using a spanner wrench until the bearing retainer is snug, then back it off 15 to 20 degrees. This is equal to 0.004" to 0.005" (.10mm to .13mm) clearance.

3. Tighten the set screw and relube through the lube fitting.
4. On valves with stem diameters 2" (50.8mm) and greater, the yoke assembly is equipped with tapered roller bearings. One bearing set is placed below the yoke bushing collar and one set is placed above this collar. All parts are retained by a bolted-on bearing retainer.
5. Tapered roller bearings do require a preload, See illustration No. 15. Preloading is accomplished by using a shim kit. If the bearings are not to be replaced, use all the shims that were in the original assembly. If the bearings are to be replaced, a new shim kit should be used.

Yoke Assembly With Needle Bearings

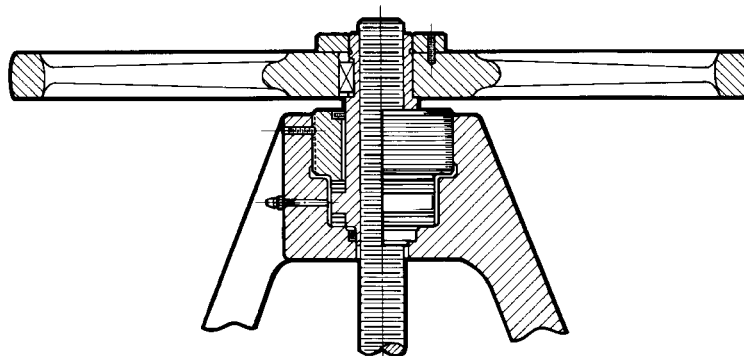

Illustration No. 14

Yoke Assembly With Taper Roller Bearings

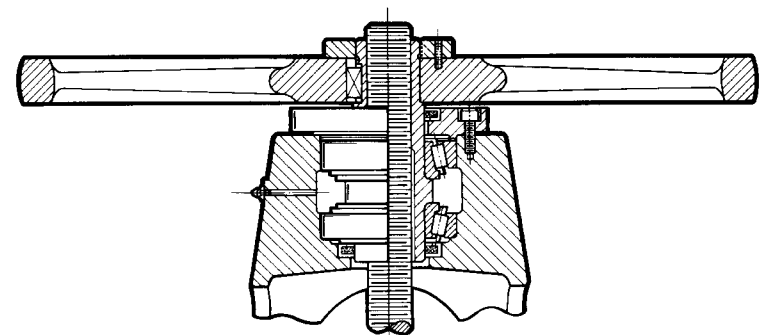

Illustration No. 15

Reassembly instructions (cont.)

Tapered Roller Bearing Preload Instructions

1. Bearing Assembly - Install the bearings, grease seals and yoke bushing in the yoke.
2. BEARING PRELOAD WARNING – FAILURE TO FOLLOW INSTRUCTIONS MAY RESULT IN BEARING FAILURE. See *illustration No. 16*.
 - a. Use a micrometer to measure the thickness of the bearing retainer flange at each measurement hole. Number each measurement hole with a grease pencil. Record the measurements.
 - b. Mark the bearing retainer flange and yoke with a grease pencil in order to know the relative position of parts and remove the bearing retainer flange.
 - c. Use a micrometer to measure the thickness of the “bearing preload washer” and record the measurement.
 - d. Install a “bearing preload washer” (tool). See Table 4 for dimensions. Install the bearing retainer flange (make certain that mating surfaces are clean) at alignment position marks and align the bolt holes. Install 3 or 4 cap screws to secure the bearing retainer at 90° or 120° intervals. Use a depth micrometer to level the bearing retainer flange and take readings to ensure that the flange remains level as the torque is increased in small increments. The preload torque is indicated in Table 5 for each applicable cap screw size. Rotate the yoke bushing after each increase in torque.
 - e. Extend a depth micrometer into each of the holes located in “a” above until it hits the top of the yoke. Record the measurements. Calculate the average dimension and record.
 - f. Remove the bearing retainer flange, cap screws and bearing preload washer (tool).
 - g. Add the average dimension recorded in “a” to the measurement recorded in “c” and record the result.
 - h. Subtract the measurement recorded in “e” from the average dimension recorded in “g” and record the result.
 - i. Shim stock thickness equal to the result recorded in “h” must be installed between the top bearing and the bearing retainer flange.

Bearing Preload Instruction

PRELOAD CAP SCREWS
TORQUE FROM TABLE 5

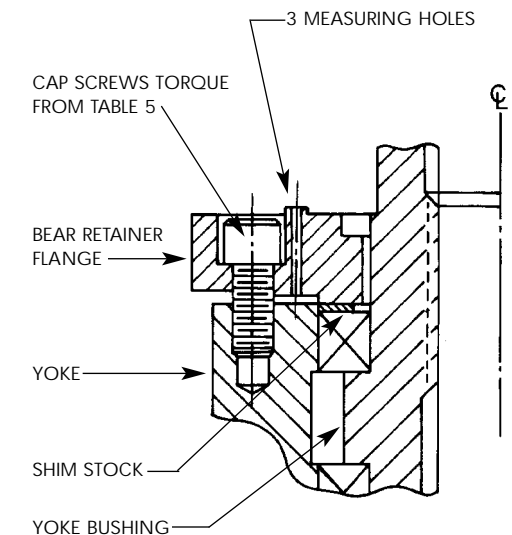
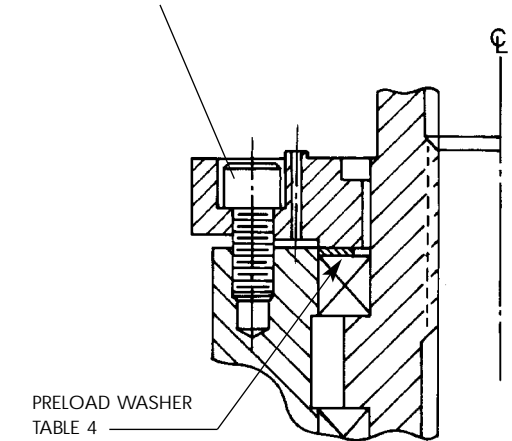

Illustration No. 16

Reassembly Instructions *(cont.)*

j. Install the bearing retainer flange on the yoke (make certain that the mating surfaces are clean), align the position marks and align the holes in the bearing retainer flange with the holes in the yoke. Install 3 or 4 cap screws at 90° intervals. Use a depth micrometer to level the bearing retainer flange and take readings to ensure that the flange remains level while the torque

is increased in small increments. Rotate the yoke bushing after each increase in torque. Apply a preload torque indicated on Table 5 to the cap screws, use a depth micrometer to take measurements and compare the measurements with those taken in step (a) above. If the measurements are the same as those recorded in step "a", then the flange has bottomed on the

yoke. If the measurements are greater than "a" measurements, then the flange has not bottomed and the bearing preload procedure should be repeated. Install the remaining cap screws and tighten in a star pattern until the torque indicated in Table 6 is developed. Be careful to keep the bearing retainer flange level while torque is applied to the cap screws.

Table 4—Dimensions For Bearing Preload Washer - in inches (mm)

Valve Stem Diameter	Washer OD		Washer ID		Washer Thickness	
	+ .005	(±.13)	+ .010	(±.25)	+ .001	(±.03)
2.000 (50.80)	5.100	(129.54)	4.56	(115.8)	.187	(4.75)
2.125 (53.98)	5.100	(129.54)	4.56	(115.8)	.187	(4.75)
2.250 (57.15)	5.687	(144.45)	5.15	(130.8)	.187	(4.75)
2.375 (60.32)	6.090	(154.69)	5.38	(136.7)	.187	(4.75)
2.500 (63.50)	7.110	(180.59)	6.40	(162.6)	.187	(4.75)
2.625 (66.68)	7.075	(179.70)	6.36	(161.5)	.187	(4.75)
2.750 (69.85)	6.985	(177.42)	6.30	(160.0)	.187	(4.75)
2.875 (73.02)	8.110	(205.99)	7.34	(185.9)	.187	(4.75)
3.000 (76.20)	8.985	(228.22)	8.12	(206.2)	.187	(4.75)
3.250 (82.55)	9.985	(253.62)	9.00	(228.6)	.187	(4.75)
3.500 (88.90)	11.360	(288.54)	10.25	(260.3)	.187	(4.75)
3.750 (95.25)	12.485	(317.12)	11.25	(285.8)	.187	(4.75)
4.250 (107.95)	12.485	(317.12)	11.25	(285.8)	.187	(4.75)

Table 5—Bearing Retainer Preload Torque

Cap Screws Diameter	Threads Per Inch	Torque In Ft. Pounds	Torque In NM	No. of Cap Screws
3/4	10	20	27	3 or 4
7/8	9	35	47	3 or 4
1	8	50	68	4
1-1/4	7	135	183	4

Table 5A

Cap Screws Diameter	Pitch	Torque in NM	No. of Cap Screws
16	2	120	3 or 4
20	2.5	240	3 or 4
24	3	400	3 or 4
30	3.5	880	4

Table 6—Bearing Retainer Final Torque

Cap Screws Diameter	Threads Per Inch	Torque in Ft. Pounds	Torque in NM
3/4	10	165	224
7/8	9	265	360
1	8	405	550
1-1/4	7	895	1215

Table 6A

Cap Screws Diameter	Pitch	Torque in NM
16	2	120
20	2.5	240
24	3	400
30	3.5	880

Reassembly Instructions for Valves with Composite Pressure Seal Gaskets Only

It is important to determine that the new composite pressure seal gasket, the bonnet and the body sealing area are in satisfactory condition before installation. The following steps will help ensure superior performance of the gasket.

1. Carefully inspect the body bore and bonnet O.D. sealing surfaces. Remove any raised metal from the entry chambers and gasket chamber regions. Repair any gouges in the sealing region in accordance with the instructions on pg. 10.
2. Inspect the new composite gasket. **Note:** All composite gaskets have cracks and wrinkles in the flexible graphite. This is a normal result of the forming process and will not affect gasket performance.
3. Be sure the anti-extrusion rings are tightly bonded to the graphitic gasket, so they will not touch the body during assembly. If any of the anti-extrusion rings are loose, carefully scrape away all flexible graphite left on the anti-extrusion ring surface and re-bond to the graphite surface using Loctite 454 or other suitable contact cement. The ends of the outer rings should touch after bonding. There should be an approximate .020 ± .005 inch gap at the ends of the inner ring.
4. Place the gasket on the bonnet with the two anti-extrusion rings facing up as shown in the illustration. The gasket should fit snugly around the bonnet, and the gasket O.D. should

not exceed the O.D. of the bonnet. This will ensure that the gasket does not catch on the body and “energize” prematurely.

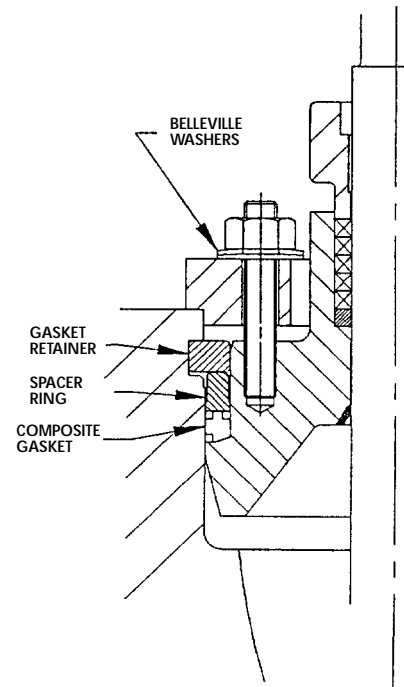

5. Install the spacer ring on the bonnet as shown with the wide end toward the gasket. The valve may now be reassembled using the assembly procedures described in the following sections for different types of bonnets, except that special torquing procedures are required as described in the following:

IMPORTANT: The composite pressure seal must remain dry until fully compacted for proper sealing!

6. Once the bonnet and bonnet retainer holes have been aligned, lightly lubricate the fasteners with high-temperature anti-seize lubricant. Assemble the Belleville washers under the nuts or capscrews. Assemble remaining parts as described in previous sections.
7. Preload the bonnet by pulling up with a well centered crane load or with come-alongs.

TABLE 7

**COMPOSITE GASKET BONNET/COVER
BOLT/NUT PULL-UP TORQUES
(FOR INITIAL PULL-UP)**

BOLT SIZE	REQUIRED TORQUE FT-LBS
3/8	30
7/16	45
1/2	70
9/16	100
5/8	135
3/4	220
7/8	350
1	540
1-1/8	770
1-1/4	1100
1-3/8	1500
1-1/2	1700
1-5/8	2300
1-3/4	3200
1-7/8	4200
2	4600

Reassembly Instructions for Valves with Composite Pressure Seal Gaskets Only *(cont.)*

8. Initially compress the pressure seal gasket making sure that the bonnet does not cock in the body.
9. While maintaining the pull up load, torque the bonnet/cover bolts evenly using a varying star pattern, until the fastener torques reach a value of 2/3 the torque given in Table 7, pg. 23.
10. After reaching 2/3 of the torque value given in Table 7, torque the bonnet nuts in small torque increments, with no more than 1/6 turn per tightening round, using a varying star pattern, until the full torque value given in Table 7 is reached.
11. Re-torque the bolts at the final torque value several times, until the gasket no longer compresses. This step is necessary due to the high resilience of the graphitic gasket.
12. Complete remaining valve assembly in accordance with the appropriate preceding section of this manual.
13. When the valve is next under pressure, either during system hydrostatic test or when put in service, re-torque the bolts to the torque values given in Table 2, pg. 7.

CAUTION

Do not use the torque values in Table 7 while the valve is under pressure.

Reassembly Instructions for Valves with Metal Gaskets Only

Type I Pressure Seal Bonnet

See *Illustration No. 7, pg. 14*

1. Place one gate half on a clean plywood board. Place the stem T-head in the recess in the gate.
2. Place the gate spacer ring into the counterbore in one gate half. Place the other gate half on top, engaging the spacer ring and stem. Holding the gate halves together, lift the stem and lower assembly into the body, engaging the gate guide rails with the grooves in the body. Lower the gate to the seats.
3. Assemble a new pressure seal gasket and the junk ring on the bonnet. Lift the bonnet assembly over the stem and lower it into the body. Be very careful not to mar the pressure seal gasket or other machined surfaces.
4. Place the gasket retainer plate and thrust washer on the body and align cap screw holes on the gasket retainer plate with the body holes.
5. Place the bonnet retainer plate over the stem and start threading onto the bonnet.
6. Place the gland over the stem.
7. Place the yoke over the stem and engage the stem threads by turning the yoke bushing counterclockwise.

When the yoke contacts the gasket retainer plate, align the cap screw holes and continue to turn the yoke bushing until the stem contacts the backseat. This will pull the bonnet and gasket up against the gasket retainer and the yoke flange up against the body.

8. Assemble the yoke flange cap screws and tighten in a star pattern using a torque wrench to values as shown in Table 2, pg. 7.
9. With the bonnet retainer cap screws flush on the bottom of the bonnet retainer, screw the bonnet retainer down until it contacts the thrust washer. Now back it off

Reassembly Instructions for Valves with Metal Gaskets Only *(cont.)*

- 1/8" (3mm) and align the gland bolts with the yoke windows.
 10. Tighten the bonnet retainer cap screws using a torque wrench in a star pattern to the values shown on Table 2, pg. 7. See step 13 below.
 11. Repack the packing chamber following instructions on pg. 6. Place the gland in position and tighten the gland nuts.
 12. Reassemble the handwheel, (or actuator) using the reverse of the instructions for disassembly.
 13. After the valve is pressurized, retighten the bonnet retainer cap screws using the same torque values in step 10. **This is important.**
3. Carefully lift the stem-gate assembly using a hoist if necessary to avoid scratching the stem or gate surfaces, and lower the assembly part way into the body with the guide rails fully engaged with the guide grooves. Remove the clamps and lower the assembly until the gate contacts the seats.
 4. Assemble a new pressure seal gasket and the junk ring onto the bonnet. Lift the bonnet over the stem, using a hoist if necessary, and lower it into the body. Be very careful not to mar the pressure seal gasket or other machined surfaces.
 5. Place the bonnet retainer plate on the body if it is a separate part, and align the cap screw holes with the body. Omit this step if the bonnet retainer is integral with the yoke.
 6. Place the gland over the stem.
 7. Place the yoke over the stem and engage the stem threads with the yoke bushing by turning the yoke bushing counterclockwise. When the yoke contacts the bonnet retainer plate or body, align the cap screw holes and continue to turn the yoke bushing until the stem contacts the backseat. This will pull the bonnet and gasket up against the gasket retainer and the yoke flange up against the body. While this is being accomplished, the studs in the body and bonnet must be aligned with the holes in the yoke (or bonnet retainer plate).
 8. Assemble the yoke cap screws or nuts and tighten in a star pattern using a torque wrench to the values shown on Table 2, pg. 7.
 9. Assemble the nuts on the bonnet studs and tighten in a star pattern using a torque wrench to the values shown on Table 2, pg. 7. See step 12 below.
 10. Repack the packing chamber following the instructions on pg. 6. Place the gland in position over the studs and tighten the gland nuts.

Types IIA & IIB Pressure Seal Bonnet

See Illustration Nos. 8 & 9. pg. 15

1. Place one gate half, seat face down, on a bed of clean rags or plywood board. Place the stem T-head into the recess in the gate.
2. Place the gate spacer ring into the counterbore in one gate half. Place the other gate half on top, engaging the spacer ring and stem. If necessary, clamp the gate halves together on top of the guide rails using "Kant Twist" type clamps. Install an eye bolt into the top of the stem. Stems 1.62" (41.1mm) and larger in diameter are drilled and tapped on the top end. See illustration 17, for clamping arrangement.

Clamping For Securing Gate Halves During Assembly/Disassembly

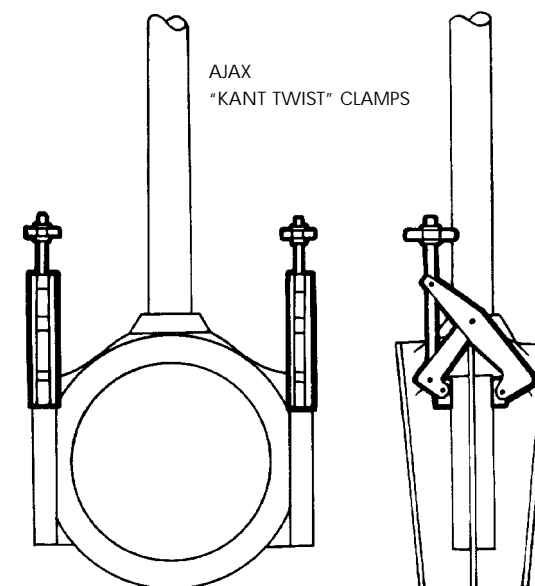

Illustration No. 17

Reassembly Instructions for Valves with Metal Gaskets Only *(cont.)*

11. Reassemble the handwheel, (or actuator) using the reverse of the instructions for disassembly.
12. After the valve is pressurized, retighten the bonnet retainer nuts using same torque values as in Step 9. **This is important.**

Type III Pressure Seal Bonnet

See Illustration No. 10, pg. 16

1. Place one gate half on a clean plywood board. Place the stem T-head into the recess in the gate.
2. Place the gate spacer ring into the counterbore in one gate half. Place the other gate half on top, engaging the spacer ring and stem. Holding the gate halves together, lift the stem and lower the assembly into the body engaging the gate guide rails with the groove in the body. Lower the gate to the seats.
3. Assemble a new pressure seal gasket, the spacer ring and junk ring on the bonnet. Lift the bonnet assembly over the stem and lower into the body. Be very careful not to mar the pressure seal gasket or other machined surfaces.
4. Assemble the gasket retainer segments into the groove.
5. Place the thrust washer on the body, and the bonnet retainer plate on top of the body. Lift the stem assembly up so that the bonnet penetrates the gasket retainer

segments and engages the threads of the bonnet retainer and bonnet. The bonnet retainer cap screw should be engaged so they are flush. Lift the stem assembly up and screw the bonnet retainer down until it contacts the body. Now back it off about 1/8" (3mm) and align the gland bolts for correct orientation.

6. Place the gland over the stem.
7. Place the yoke over the stem and engage the stem threads by turning the yoke bushing counterclockwise. When the yoke contacts the body, align the cap screw holes and continue to turn the yoke bushing until the stem contacts the backseat firmly. This will pull the bonnet, gasket, and spacer ring up against the bonnet retainer and the yoke up against the body.
8. Assemble the yoke flange cap screws and tighten the cap screws using a torque wrench to the values shown on Table 2, pg. 7. See step 12 below.
9. Tighten the bonnet retainer cap screws in a star pattern using a torque wrench to the values shown on Table 2, pg. 7.
10. Repack the packing chamber, following the instructions on pg. 6. Place the gland in position and tighten the gland nuts.
11. Reassemble the handwheel, (or actuator) using the reverse of the

instructions for disassembly.

12. After the valve is pressurized, retighten the bonnet retainer cap screws, step 8, using the same torque values. **This is important.**

Type IV & V Pressure Seal Bonnet

See Illustration Nos. 11 & 12, pg. 17

1. Place one gate half seat face down on a bed of clean rags or plywood board. Place the stem T-head into the recess in the gate.
2. Place the gate spacer ring into the counterbore in one gate half. Place the other gate half on top, engaging the spacer ring and stem. Clamp the gate halves together near the top of the guide rails. Place an eyebolt in the top end of the stem. Stems 1.62" (41.1mm) and larger are drilled and tapped on the top end. See illustration No. 17, pg. 25, for clamping arrangement.
3. Carefully lift the stem-gate assembly, using a hoist in the eyebolt if necessary, so as to avoid scratching the stem or gate surfaces. Lower the assembly part way into the body with the gate guide rails engaged with the body guide groove. Remove the clamps and lower the assembly until the gate contacts the seats.

Reassembly Instructions for Valves with Metal Gaskets Only *(cont.)*

4. Assemble a new pressure seal gasket, the spacer ring, junk ring and gland on the bonnet. Lift the bonnet using a hoist if necessary, and place it over the stem and lower into the body. Be very careful not to mar the pressure seal gasket or other machined surfaces.
5. Install the gasket retainer ring segments in the body groove. Place the bonnet retainer over the stem onto the top of the body.
6. Lift the stem and bonnet assembly up through the gasket retainer and realign the studs with the bonnet retainer and match marks.
7. Assemble the nuts on the bonnet retainer studs and snug them up.
8. Lift the yoke assembly over the stem and engage the stem threads by turning the yoke bushing counterclockwise. When the yoke contacts the body, align the bolt holes (or match mark) and continue to turn the yoke bushing until the stem contacts the backseat firmly.
9. Install the cap screw (or yoke lock ring) and tighten the cap screws (or studs and nuts) to the torque values shown on Table 2, pg. 7. See step 13 below.
10. Tighten the bonnet retainer nuts carefully using a torque wrench in a star pattern to the values shown on Table 2, pg. 7.
11. Install new packing following the instructions on pg. 6. Place the gland in position and tighten the gland bolts evenly.
12. Reassemble the handwheel (or actuator) using the reverse of the instructions for disassembly.
13. After the valve has been pressurized, retighten the bonnet retainer nuts to the same torque values used in step 10. **This is important.**

Appendix A

Procedures For Removing Manual And Electro-mechanical Actuators From Valve Yokes

Equiwedge pressure seal gate valves are often equipped with a variety of manual and/or electro-mechanical actuators. A number of these are illustrated in this section. Basically, there are two types of actuators:

- (a) Those which take both torque and thrust forces.
- (b) Those which supply only the torque to open or close the valve.

In type (a), the actuator is equipped with a stem nut and thrust bearings that can withstand the thrust and torque loads imposed. **THIS TYPE SHOULD NOT BE REMOVED WITH PRESSURE IN THE VALVE.**

In type (b), the actuator is connected to the valve yoke bushing by a key or spline, or by other means, and delivers only the torque load.

Limitorque Actuator

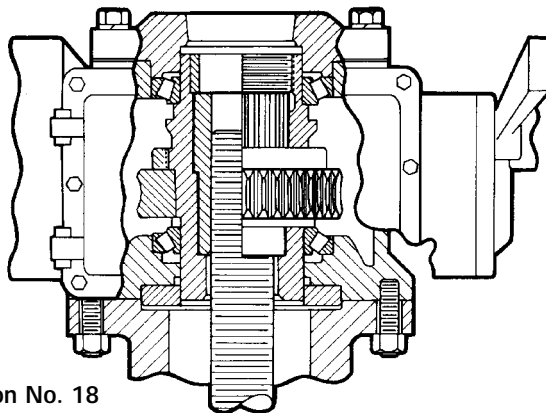

Illustration No. 18

The most common is type (a) because of the non-revolving, rising stem. This type is used in both manual and electro-mechanical actuators.

TYPE (a) TORQUE AND THRUST ACTUATOR DISASSEMBLY

Limitorque Actuator *Illustration No. 18*

Rotork Units *Illustration No. 19*

Torkmatic units (Manual) *Illustration No. 20, pg. 29*

Auma units *Illustration No. 21, pg. 29*

Follow these guidelines:

1. Position the valve gate just off the seat.
2. Disconnect the electrical wiring to the actuator.
3. Make sure the packing gland nuts are tight.

4. Position a chain hoist of suitable capacity to support the actuator so that the handwheel can be rotated. The pull point must be directly in line with the stem.
5. Remove all nuts or cap screws from the under side of the yoke flange.
6. Turn the actuator handwheel to close the valve. This will cause the actuator to rise and unthread the stem nut from the stem. As this takes place, the weight of the actuator should be taken by the hoist to prevent damage to the stem threads.
7. When the stem threads are disengaged, lift the actuator clear of the stem and place it down on a clean area for further disassembly, if required. If there is additional work to do on the valve, refer to the proper valve type and proceed to disassemble the valve.

Rotork Actuator

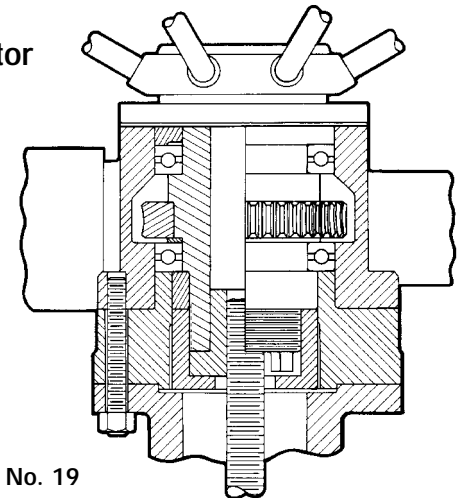

Illustration No. 19

Appendix A (cont.)

TYPE (b) TORQUE ONLY DISASSEMBLY PROCEDURE

Limitorque *Illustration No.22*

AUMA *Illustration No.23*

1. Position the valve gate just off the seat.
2. Disconnect the electrical wiring to the actuator.
3. Position a chain hoist of adequate capacity to the actuator. The pull point must be directly in line with the valve stem.
4. Remove all nuts or cap screws from under the flange.
5. Using a hoist, raise the actuator above the yoke bushing and position away. If the actuator is keyed to the yoke bushing, remove the key so it will not be lost.

If there is further work to do on the valve, refer to the proper valve type and proceed with disassembly.

CAUTION:
UPON REASSEMBLY OF A VALVE EQUIPPED WITH AN ELECTRO-MECHANICAL ACTUATOR, THE OPEN AND CLOSED LIMIT SWITCHES MUST BE RESET. PLEASE REFER TO THE MAINTENANCE MANUAL PROVIDED BY THE ACTUATOR MANUFACTURER FOR APPROPRIATE INSTRUCTIONS.

WARNING
SHOULD IT BECOME NECESSARY TO CHANGE THE TORQUE SWITCH SETTING FOR ANY REASON, YOUR LOCAL EDWARD VALVES REPRESENTATIVE SHOULD BE CONTACTED IN ORDER THAT A CORRECT NEW SET CAN BE OBTAINED FROM THE FACTORY.

The torque switch of the motor actuated valve is set during factory assembly to close the valve against the specified differential pressure and requires the same special attention for resetting.

Torkmatic Manual Actuator

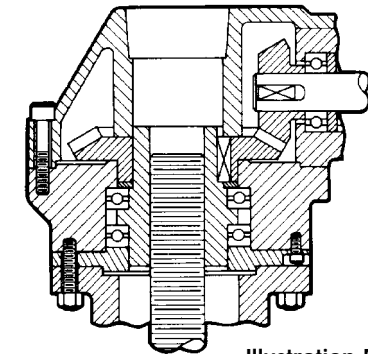

Illustration No. 20

Auma Actuator

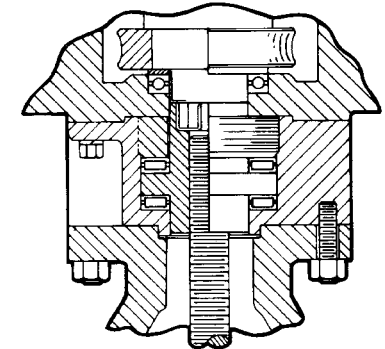

Illustration No. 21

Limitorque Actuator

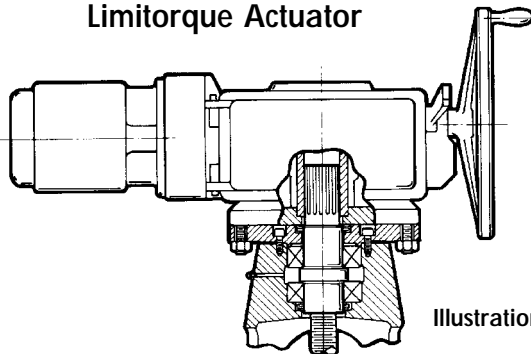

Illustration No. 22

Auma Actuator

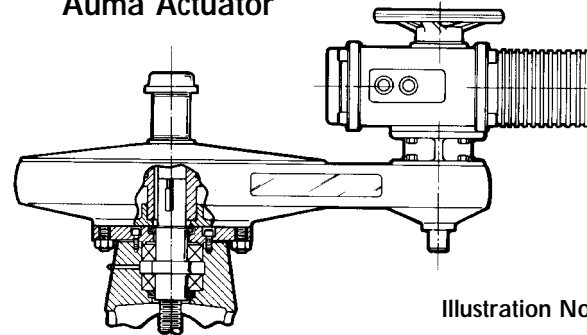

Illustration No. 23

Appendix B

Valve Tools Available For Rental

The following tools are available from the Edward Valves Raleigh plant on a rental basis:

Dexter Seat Refinishing Machines for valves sizes 3 to 28. See *illustration No. 24*.

Portable boring machines that can be used to machine the pressure seal area of the body in case of damage or because of weld repair. See *illustration no. 25*.

Contact your local Edward Valves representative for details on cost and availability.

A group of skilled service representatives is also available to assist in repairs.

Typical Dexter Gate Valve Seat Refinishing Machine

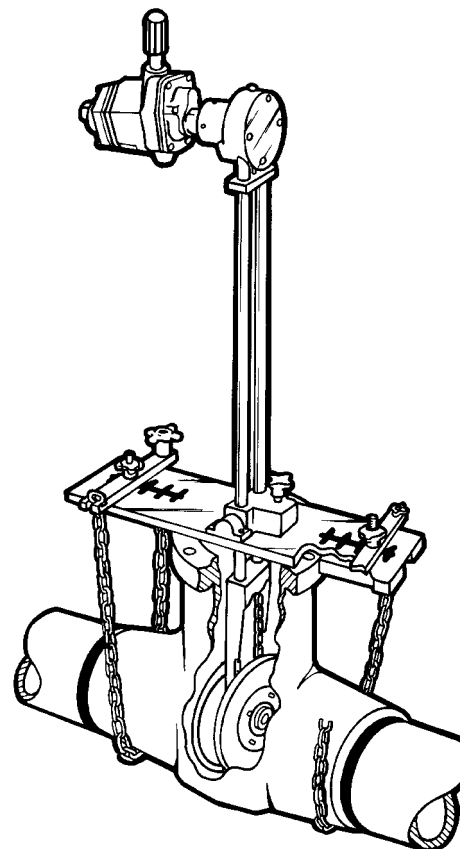

Illustration No. 24

Portable Boring Machine Attached To Gate Valve Body

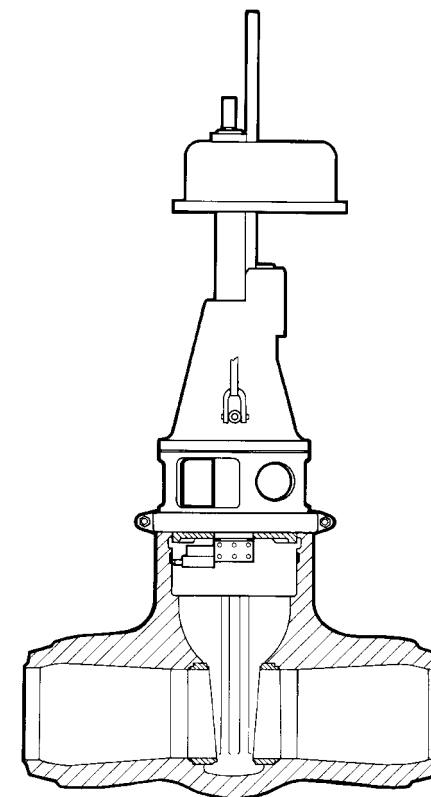

Illustration No. 25



Flowserve Corporation has established industry leadership in the design and manufacture of its products. When properly selected, this Flowserve product is designed to perform its intended function safely during its useful life. However, the purchaser or user of Flowserve products should be aware that Flowserve products might be used in numerous applications under a wide variety of industrial service conditions. Although Flowserve can (and often does) provide general guidelines, it cannot provide specific data and warnings for all possible applications. The purchaser/user must therefore assume the ultimate responsibility for the proper sizing and selection, installation, operation, and maintenance of Flowserve products. The purchaser/user should read and understand the Installation Operation Maintenance (IOM) instructions included with the product, and train its employees and contractors in the safe use of Flowserve products in connection with the specific application.

While the information and specifications contained in this literature are believed to be accurate, they are supplied for informative purposes only and should not be considered certified or as a guarantee of satisfactory results by reliance thereon. Nothing contained herein is to be construed as a warranty or guarantee, express or implied, regarding any matter with respect to this product. Because Flowserve is continually improving and upgrading its product design, the specifications, dimensions and information contained herein are subject to change without notice. Should any question arise concerning these provisions, the purchaser/user should contact Flowserve Corporation at any one of its worldwide operations or offices.

For more information about Flowserve Corporation, contact www.flowserve.com or call USA 1-800-225-6989.

FLOWSERVE CORPORATION
FLOW CONTROL DIVISION
Edward Valves
1900 South Saunders Street
Raleigh, NC 27603 USA

Toll- Free Telephone Service
(U. S. and Canada)
Day: 1-800-225-6989

After Hours Customer Service
1-800-543-3927

US Sales Offices
Phone: 919-832-0525
Facsimile: 919-831-3369
Facsimile: 919-831-3376

Visit Our Website
www.edwardvalves.com

