



# USER INSTRUCTIONS

## G4, G4Z and G4R Marathon

Sleeveline® Plug Valves

*Non-Lubricated Plug Valves for Chemical Service*

## Installation Operation Maintenance

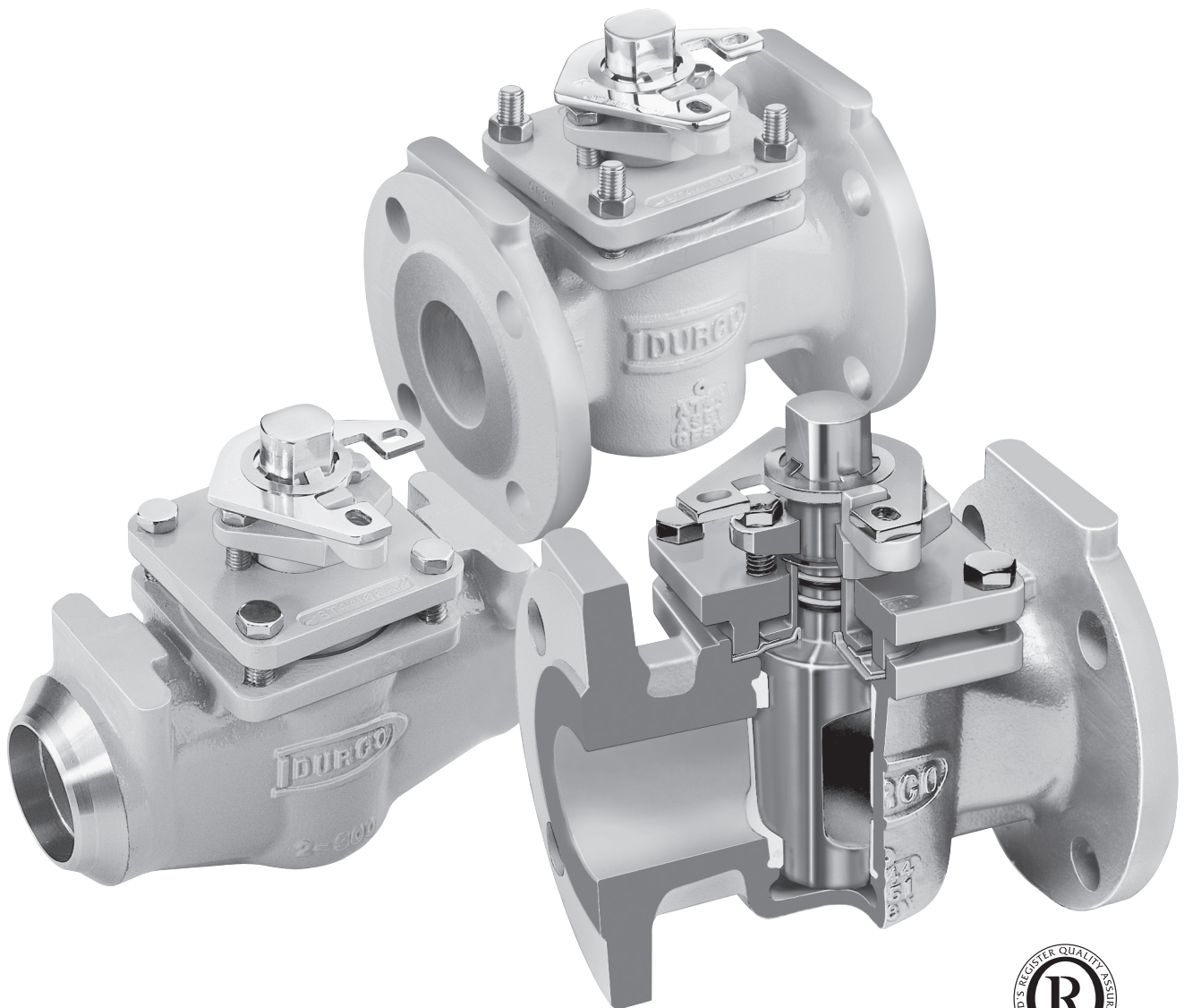

Quality  
System  
Certificate

FCD DVENIM0270-07  
(Bulletin V-270)

## FOREWORD

Flowserve Corporation, Flow Control Division, has established this Installation, Operating, and Maintenance Manual to facilitate field installation, operation and repair of G4 Marathon, G4Z Marathon and G4R Marathon valves.

It is recommended that questions or concerns involving the processes described in this manual be directed to the local

Sales Representative of Flowserve Corporation. Only Flowserve replacement repair parts and assembly tooling made or designed by Flowserve Corporation should be used. Part numbers referenced in the following sections are available from Flowserve Corporation, Flow Control Division.

## TABLE OF CONTENTS

| SECTION | TITLE  | PAGE  |
|---------|--|-------|
|         | FOREWORD   |       |
| I       | INSTALLATION INSTRUCTIONS – FLANGED AND WELDED G4 Marathon, G4Z Marathon, G4R Marathon | 2     |
| II      | OPERATING/MAINTENANCE – G4 Marathon, G4Z Marathon, G4R Marathon                        | 3     |
| III     | VALVE DISASSEMBLY – G4 Marathon, G4Z Marathon, G4R Marathon                            | 4     |
| IV      | PRESSURE CONTAINING FASTENERS  | 5-6   |
| V       | A. VALVE ASSEMBLY – 1/2" & 3/4" G4 Marathon, G4R Marathon                              | 7-8-9 |
|         | B. VALVE ASSEMBLY – 1"-8" G4 Marathon, G4R Marathon                                    | 10-12 |
| VI      | ASSEMBLY SPECIFICATIONS – FIRESAFE VALVES G4Z Marathon, G4ZR Marathon, G4ZHF Marathon  | 13-15 |
| VII     | RECOMMENDED SPARE PARTS  | 16    |

## SECTION I

### INSTALLATION INSTRUCTIONS – FLANGED AND WELDED G4 MARATHON, G4Z MARATHON, G4R MARATHON

#### FLANGED:

Installation of Flowserve flanged valves is best accomplished by locating valves in pipeline flanges, assuring all corrosion and foreign materials are removed from pipe flange and then center gaskets with the valve flanges. Fasteners or taper pins should be used to align holes and locate gaskets. Fasteners should be tightened to the corresponding valve and fastener size.

#### WELDED:

Flowserve Corporation, Flow Control Division recommends using only qualified welding procedures and personnel for weld installation of G4 Marathon and G4R Marathon valves.

The following precautions should be observed:

1. The valve should be inspected prior to welding to assure that no foreign materials obstruct the flow passageway and that the weld preparation are free of corrosion and physical damage.
2. The valve should be in the open position while being welded. Open position is when the flow indicator on the plug stem is pointing in the direction of the pipeline.
3. Valves of the G4 Marathon and G4R Marathon style contain various seal materials which have a maximum temperature limitation.

(Refer to Table 1.1 for temperature limitations.) The valve body sleeve area should not exceed this temperature during welding including preheats, interpasses, or post weld heat treatments as applicable. Due to welding variables, contact the Flowserve Corporation, Cookeville, TN, Valve Operation for additional information or recommendations.

4. Leak-off or buffering connections should be installed after the valve has been welded into the pipeline. A suitable thread sealant is recommended for installing such connections.

| MATERIAL DESCRIPTION                            | MAXIMUM SERVICE TEMPERATURE |
|---|-----------------------------|
| Ultra High Molecular Weight Polyethylene (UMPE) | 200°F (93°C)                |
| Tetrafluoroethylene Polymer (PTFE)              | 400°F (204°C)               |
| Durlon 2 (TFM)                                  | 450°F (232°C)               |
| Duriron Durco 82 (DU-82)                        | 275°F (135°C)               |

**SECTION II**

**OPERATING/MAINTENANCE INSTRUCTIONS FOR  
G4 MARATHON, G4Z MARATHON, G4R MARATHON**

Maintenance requirements for G4 Marathon, G4Z Marathon and G4R Marathon valves may vary due to operating conditions of the process. Factors such as operating temperature, pressure, solids content, and frequency of cycling can influence valve performance and maintenance requirements.

Seal wear is compensated by adjusting appropriate parts. For G4 Marathon, G4Z Marathon and G4R Marathon valves, there are three possible leak paths:

1. Top Cap (bonnet)
2. Stem
3. Line (through)

Corresponding adjustments for each leak path are as follows:  
NOTE: Refer to Figure II-1 or Figure VI-1 for parts identification.

**1. Top Cap (bonnet)**

Leakage due to thermal or pressure cycling is eliminated by snugging the top cap fasteners (Part 3A) in a “criss-cross” pattern. This adjustment is most effective when the valve is not pressurized. It is important that the top cap fasteners not be tightened excessively and that torque values applied be within industry standard for fasteners.

**2. Stem**

Leakage due to wear of the diaphragm, and/or wear to the sleeve (primary seal) is eliminated by tightening the adjuster fasteners (Part 12A) in 1/4 turn increments. It is recommended that the adjuster fasteners be tightened evenly.

The valve should be operated between adjustments to assure that the plug properly seats itself into the sleeve. If leakage persists after repeated adjustments, the sleeve and diaphragm will require replacement as covered in Section V A and V B or Section VI.

**3. Line (through)**

Through leakage due to wear of the primary seal can be eliminated by tightening the adjuster fasteners (Part 12A) in 1/4 turn increments. It is recommended that the fasteners be tightened evenly.

The valve should be operated during adjustments to prevent excessive operating torque. Should leakage persist after repeated adjustments, the sleeve will require replacement as covered in Section V A and V B or Section VI.

**FIGURE II-1  
TYPICAL ASSEMBLY OF G4 MARATHON AND  
G4R MARATHON VALVE**

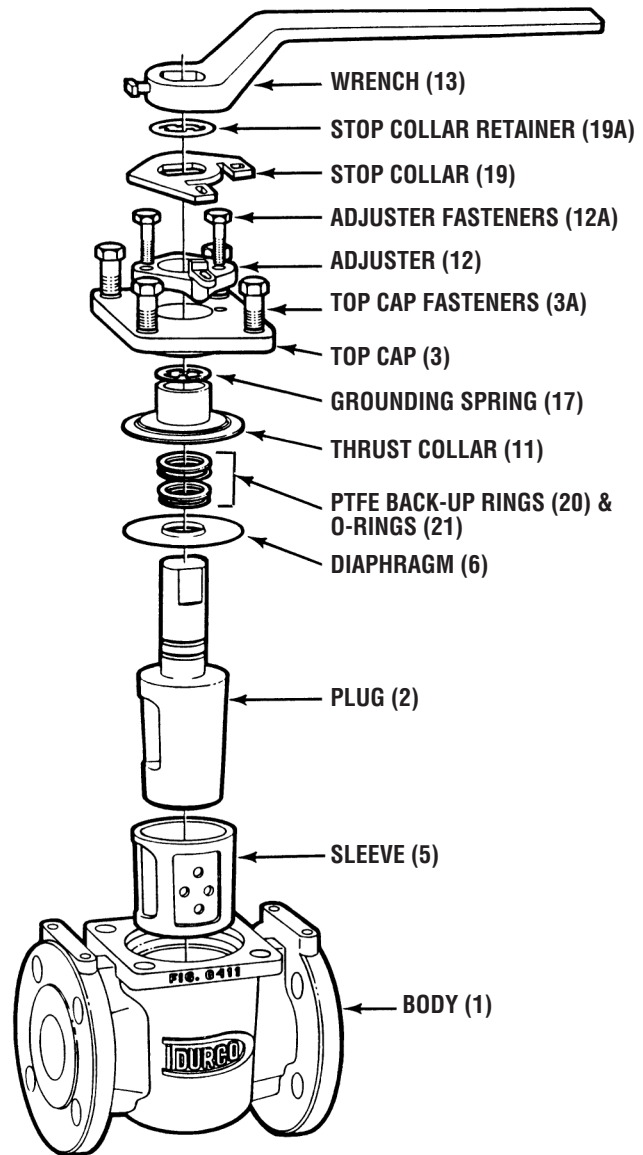

**▲ WARNING**  
*To avoid personal injury and prevent damage to equipment, do not operate or repair this valve without observing the following procedures outlined in this manual.*

## SECTION III

### VALVE DISASSEMBLY – G4 MARATHON, G4Z MARATHON, G4R MARATHON

#### Recommended Precautionary Measures

1. Valves must be relieved of process fluid and pressure prior to disassembly.
2. Personnel performing disassembly must be suitably protected and alert for emission of hazardous process fluid.

#### Disassembly Steps

NOTE: Refer to Figure II-1 or VI-1 for parts identification. If an actuator or gearbox operates the valve, alignment marks should be noted to assure correct orientation when reassembled. This may best be accomplished by making matching marks on the plug stem and operator housing with no burrs on the plug stem.

1. Gradually loosen adjuster fasteners (Part 12A) – DO NOT REMOVE.
2. Turn plug (Part 2) in order to raise the plug to vent any material trapped in the valve (see note below).  
NOTE: If there is no upward movement of the plug (Part 2), it will be necessary to devise a method of lifting the plug upward. This may require removal of the valve operator (Step 3). This operation should be undertaken noting the above precautionary measures. Methods of plug removal must include protective measures on plug stem and plug end.
3. **WARNING: Do not loosen or remove top cap fasteners (Part 3A) when removing an operator or accessory. Remove the operator by unfastening it from the bracket.**
4. Once the plug (Part 2) has lifted, the adjuster fasteners (Part 12A) can be completely removed.

5. Gradually loosen but DO NOT REMOVE all of the top cap fasteners (Part 3A). Turn the plug until it is loose from the sleeve (Part 5) and all pressure has been vented. (Again, it may be necessary to use a mechanical means to move the plug upwards.)
6. Remove the top cap fasteners (Part 3A) and top cap (Part 3) from the plug stem (Part 2).
7. Remove the plug (Part 2) from the body (Part 1).
8. Remove the grounding spring (Part 17) and thrust collar (Part 11) from plug stem (Part 2).
9. Remove the o-rings (Part 21), backup rings (Part 20) and the diaphragm (Part 6) from the plug stem (Part 2).
10. Inspect the valve sleeve (Part 5) for wear or damage, especially scratches near the top, bottom, and port areas. If wear or damage is excessive, the sleeve should be replaced.
11. Remove sleeve (Part 5) as follows:  
NOTE: Care should be taken not to damage the internal body bore.
  - a. Using a screwdriver and mallet, cut the old sleeve through one of the port openings, top and bottom.
  - b. Grasp the sleeve with a pair of pliers while twisting, and lift the sleeve from the body.
12. Thoroughly clean all valve parts with an acceptable cleaner.
13. Inspect parts for damage. Look for marred, scratched, or rough sealing surfaces on the valve plug (Part 2).  
NOTE: Reinstallation of damaged or unclean parts will ruin any replacement seals installed into the valve.

## SECTION IV

### PRESSURE CONTAINING FASTENERS

#### Material Selection

Selecting the proper fastener material is the ultimate responsibility of the customer because the supplier does not typically know in what service the valves will be used or what elements may be present in the environment. Flowserve normally supplies B7 (carbon steel) for ductile cast iron and carbon steel valves. For stainless steel and high alloy valves, B8 (stainless steel) fasteners are supplied as standard. All fasteners used must have a minimum yield strength of 40,000 PSI, a minimum elongation of 12% and be compatible with the process fluid. Determining compatibility to the process fluid goes beyond a material being resistant to general corrosion because the more important consideration is a material's resistance to stress corrosion cracking. Depending on the service, it may make sense to use B7 fasteners on high alloy valves. One such service would be marine environments because of stainless steel's susceptibility to stress corrosion cracking in chloride environments. Another key aspect of fasteners is frequent visual inspection. Because of the common practice of using steel fasteners rather than stainless steel to avoid chloride stress corrosion cracking, visual inspection is recommended to monitor the general corrosion of these fasteners. If jacketing or insulation is used on a valve,

it must be periodically removed for visual inspection of the fasteners. If you wish assistance in determining the proper fasteners to use, please refer to the attached chart.

#### Design & Type

The Flowserve valve design standards adopt ASME B18.2.1 (1996) as the standard for fastener type and design. This national standard requires that finished hex "head" cap screws be used when the head of the fastener is turned. A finished hex "head" cap screw and a heavy hex cap screw have a bearing surface under the head to minimize frictional resistance during tightening. They also comply to qualified body diameters and fully formed head dimensions. Cookeville Valve Division's policy is to use finished hex "head" and heavy hex "head" cap screws for all pressure retaining fasteners. This includes top caps, packing adjusters, plug adjusters, bottom caps, body halves or other pressure retaining components. Compliance is made with ANSI B18.2.2 (1987), Square and Hex Nuts, when studs and heavy hex nuts are required. Additional information on these items may be obtained from the Flowserve Corporation, Cookeville Valve Operation, Cookeville, Tennessee.

**TABLE 1  
CAP SCREWS - STUDS**

|  |   |
|--|---|
| HHCS - Finished Heavy Hex Head Cap Screw | Alloy identification stamp required on each piece.  |
| HCS - Finished Hex Head Cap Screw        | Certification required.   |
| STUD - Stud                              | Alloy Specification (40 KSI Minimum Yield Strength, 12% Minimum Elongation)   |
| Dimensions per ASME B18.2.1              |   |
| B840 -                                   | Stainless Steel per ASTM A193, Grade B8M2 or B8M3   |
| B7 -                                     | Chromium - Molybdenum Alloy Steel per ASTM A193, Grade B7   |
| B7M -                                    | Chromium - Molybdenum Alloy Steel per ASTM A193, Grade B7M, 100% hardness tested  |
| B7MT -                                   | Chromium Molybdenum Alloy Steel per ASTM A193, Grade B7M, 100% hardness tested, PTFE coated, Dupont SP11C, Type B - Color blue or green |
| B8MC2 -                                  | Per ASTM A193, Grade B8M (AISI Type 316), Class 2   |
| C20 -                                    | Carpenter C20, CB-3 (UNS N08020), ASTM B473, 40 KSI Min. Yield Strength, 12% Min. El.   |
| HC -                                     | Hastelloy C276 (UNS N10276), ASTM B574  |
| I625 -                                   | Inconel 625 (UNS N006625), ASTM B446  |
| I825 -                                   | Incoloy 825 (UNS N08825), ASTM B425, 40 KSI Min. Yield Strength, 12% Min. El.   |
| IN -                                     | Inconel 600 (UNS N0660), ASTM B166, 40 KSI Min. Yield Strength, 12% Min. El.  |
| M -                                      | Monel (UNS N04400), ASTM B164, Class A or B, 40 KSI Min. Yield Strength, 12% Min. El.   |
| HB -                                     | Hastelloy B (UNS 10665), ASTM B335  |
| I718 -                                   | Incoloy 718, AMS 5595B, ASTM B637   |
| MKH -                                    | Monel K-500, Cold drawn and aged hardened, QQN-286 and ASTM F468  |
| L7 -                                     | Chromium-Molybdenum Alloy Steel per ASTM A320, Grade L7   |
| L7M -                                    | Chromium-Molybdenum Alloy Steel per ASTM A320, Grade L7M, 100% hardness tested  |
| L7T -                                    | Chromium-Molybdenum Alloy Steel per ASTM A320, Grade L7, PTFE coated, Dupont SP11C, Type B - Color green                                |
| L7MT -                                   | Chromium-Molybdenum Alloy Steel per ASTM A320, Grade L7M, 100% hardness tested, PTFE coated, Dupont SP11C, Type B - Color green         |
| N -                                      | Nickel per ASTM B160 (UNS N0220), 40 KSI Min. Yield Strength, 12% Min. El.  |
| B7YC -                                   | Chromium-Molybdenum Steel per A193, Grade B7, Yellow Zinc Dichromate Plated   |

## SECTION IV

### PRESSURE CONTAINING FASTENERS

| TABLE 2<br>NUTS                                       |  |
|---|--|
| HN -  | Finished Heavy Hex Nut   |
| XN -  | Finished Hex Nut   |
| HXN -   | Regular Heavy Hex Nut  |
| Dimension per ANSI B18.2.2                            |  |
| Alloy identification stamp is required on each piece. |  |
| Certification required.                               |  |
| 8 -   | 304 Stainless Steel per ASTM A194, Grade 8   |
| 8M -  | 316 Stainless Steel per ASTM A194, Grade 8M  |
| 2H -  | ASTM A194, Grade 2H  |
| 2HM -   | ASTM A194, Grade 2HM   |
| 7M -  | ASTM A194, Grade 7M, 100% hardness tested  |
| 7MT -   | ASTM A194, Grade 7M, 100% hardness tested, PTFE coated, Dupont SP11C, Type B - Color green |
| M -   | Monel (UNS N04400), ASTM B164, Class A or B, or QQN-281, Class B                           |
| HB -  | Hastelloy B (UNS 10665), ASTM B335   |
| HC -  | Hastelloy C276 (UNS N10276), ASTM B574   |
| I625 -  | Inconel 625 (UNS N06625), ASTM B446  |
| I718 -  | Incoloy 718, AMS 5596B, ASTM B637  |
| I825 -  | Incoloy 825 (UNS N08825), ASTM B425  |
| L7 -  | Chromium-Molybdenum Alloy Steel per ASTM A194, Grade 7                                     |
| L7M -   | Chromium-Molybdenum Alloy Steel per ASTM A194, Grade 7M, 235 BHN Max, ASTM A320, Section 9 |
| MKH -   | Monel K-500, Cold drawn and aged hardened, QQN-286 and ASTM F467                           |
| 8F -  | 303 Stainless Steel per ASTM A194, Grade 8F  |
| 2HYC -  | ASTM A194, Grade 2H, Yellow Zinc Dichromate Plated   |

**SECTION V**

**A. VALVE ASSEMBLY – 1/2" & 3/4" G4 MARATHON, G4R MARATHON**

Valve assembly will require usage of a repair tooling kit that is specific to the size of the valve. These kits can be obtained from Flowserve FCD, Cookeville, TN.

1. Apply Durco Seal 1028B to the inside of the tapered bore in the body and permit to dry before assembly. RAD-1 material is used for nuclear applications.
2. Assemble sleeve into body with a coining die, part #BY81917A. Position coining die so locating pins are located in bonnet flange holes in body. Position sleeve in coining die so that sleeve holes are centered over body ports (Figure V A-1). Place push rod and push rod guide in coining die and push sleeve into body until push rod stops on push rod guide (Figure V A-2).

**FIGURE V A-1  
ASSEMBLE SLEEVE**

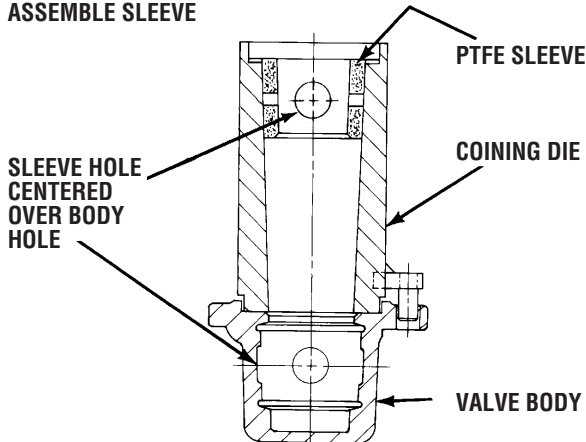

**FIGURE V A-2  
PUSH SLEEVE IN BODY**

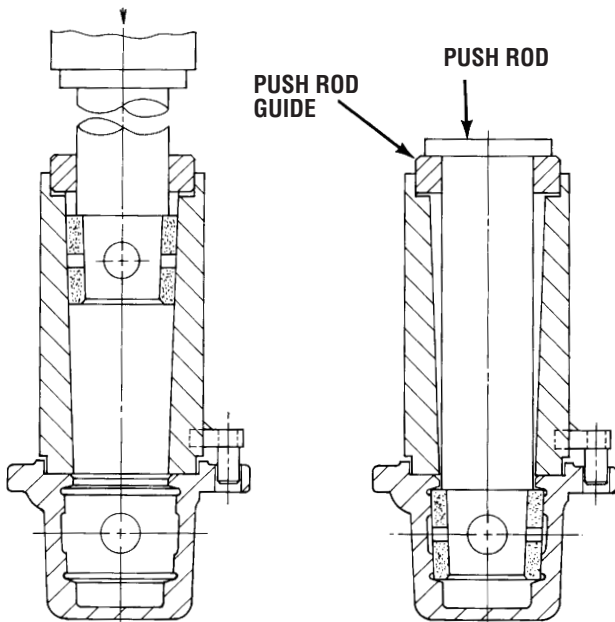

3. Size sleeve. Check sleeve in body to make sure sleeve vent holes are still centered between body ports. Apply a light coat of silicone lubricant to sizing Plug #1 and sizing Plug #2, part #BY80017B & C. Push sizing Plug #1 into sleeve until the sizing plug flange bottoms against the counterbore of the valve body. Remove #1 sizing plug and now push #2 sizing plug in the same manner, but HOLD SIZING PLUG IN PLACE for 15 SECONDS (Figure V A-3).

1. Rough Size With Plug #1
2. Finish Size With Plug #2 (Hold for 15 Seconds)

**FIGURE V A-3  
SIZE SLEEVE**

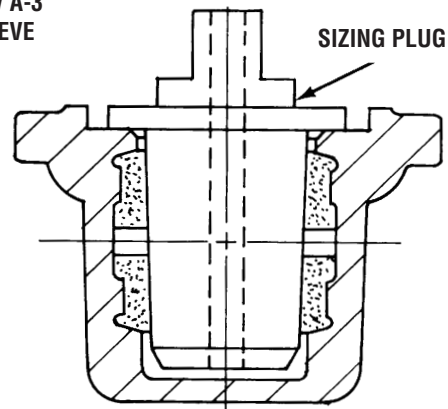

4. On a flat surface place the top cap and adjuster subassembly over the thrust collar. Thread the fasteners until snug.

**FIGURE V A-4  
PRESET ADJUSTER, THRUST COLLAR  
AND TOP CAP**

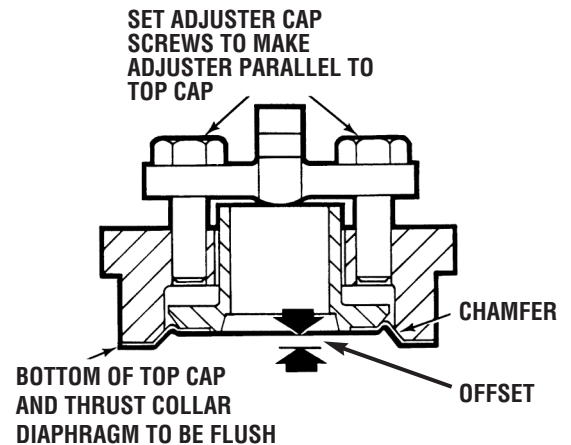

**SECTION V**

**A. VALVE ASSEMBLY – 1/2" & 3/4" G4 Marathon, G4R Marathon**

5. The plug stem and diaphragm guide are to be checked for nicks or burrs before installing the diaphragm. Nicks on these surfaces could result in scratches on the lip of the diaphragm. Assemble diaphragm over plug stem with the aid of the diaphragm guide, part #BY86272B, and assembly tool, part #BY80019A (Figure V A-5).

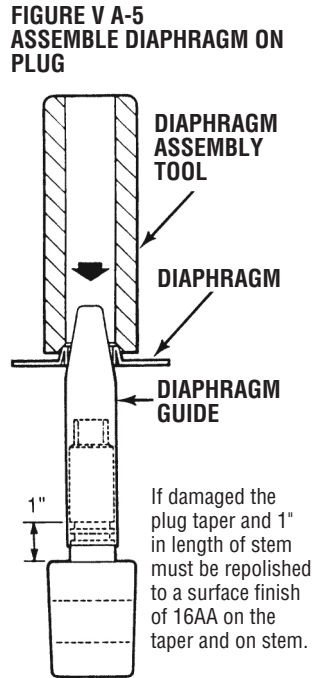

6. Using diaphragm guide to protect the o-ring from the stem edge, install the first o-ring by "rolling" it with your fingers over the guide and into the lower stem groove (Figure V A-6). Install PTFE split ring in a similar manner such that it is located above the o-ring inside the lower groove. See Figure V A-7.

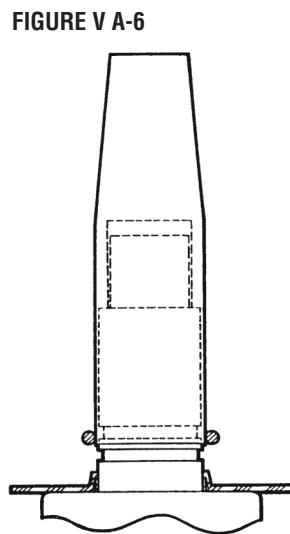

7. Install second o-ring and split ring in the upper groove in a similar manner, except that the diaphragm guide should be raised so that the lower edge of the guide does not contact the lower o-ring assembly. See Figure V A-7. Coat both o-ring assemblies liberally with Krytox® grease. Remove the guide.

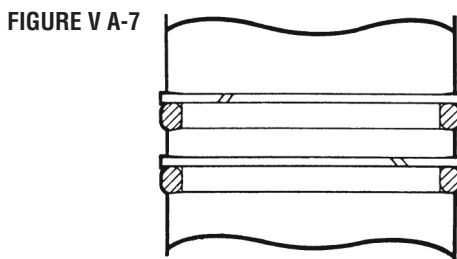

8. Place the thrust collar/ diaphragm over the plug stem and gently maneuver it over the o-rings onto the PFA diaphragm. With the thrust collar guide, P/N BY86273B, centering the thrust collar assy; force down (with arbor press) the thrust collar guide to seat the thrust collar on the diaphragm. See Figure V A-8. Remove guide from plug stem.

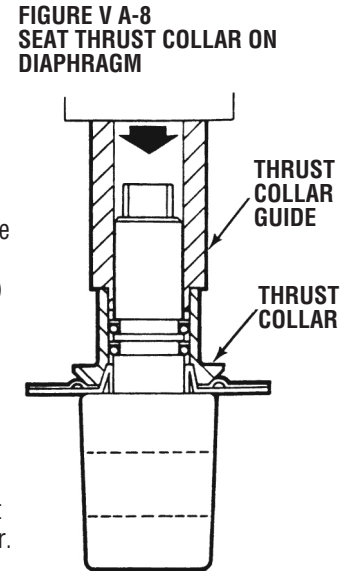

9. Place grounding spring over plug stem sliding it down to the thrust collar.
10. Apply a thin, even film of silicone or customer approved lubricant to the entire surface of the 2° plug taper.
11. Take plug (preassembled with diaphragm, thrust collar and grounding spring) and place it into body. Using a soft head mallet, tap top of plug slightly to seat plug into sleeve taper. The plug at this time will be setting up above the body counterbore approximately 1/4". The plug ports should be lined up in an open position.
12. Place the top cap assembly over plug and slide it down until it rests on the thrust collar.
13. Assemble four fasteners thru top cap and body. With "U" shaped push plate, part #BY86592A, resting on the top cap (Figure V A-9), force the top cap down (with arbor press or pneumatic clamping arrangement) to seat the top cap against the valve body counterbore. While holding the cap in this position, assemble nuts on underside of body flange to a finger tight position against the flange.

**FIGURE V A-9  
ASSEMBLE TOP CAP ASSEMBLY OVER PLUG AND PUSH INTO BODY. APPLY THREAD LOCKING COMPOUND.**

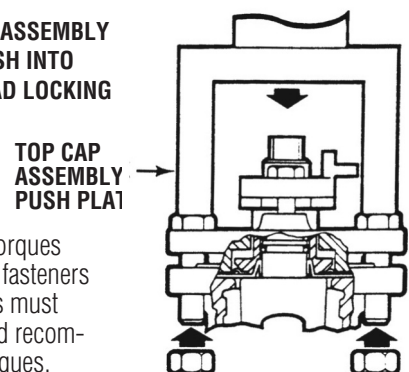

NOTE: All fastening torques are for corrosion free fasteners and nuts. Precautions must be taken not to exceed recommended fastening torques.



## SECTION V

### A. VALVE ASSEMBLY – 1/2" & 3/4" G4 MARATHON, G4R MARATHON

14. Apply thread locking compound to the threads of the top cap fasteners. Tighten the four top cap fasteners to 7 ft-lbs using a torque wrench. Reference Torque Table #1a & 1b on page 12.
15. Loosen the adjuster fasteners to approximately 3/16" above adjuster. Then rotate the valve plug back and forth 3 times, making it rise upward.
16. Retighten adjuster fasteners to a torque of 10 to 12 in-lbs. or until the height of the plug port is positioned approximately 1/16" above to flush with the body port, whichever occurs first.
17. Rotate plug back and forth a couple times to make sure the stops and ports line up properly. The final assembled valve should look similar to Figure V A-10.
18. LEAK TESTING: Anytime a valve has been modified in any manner, including fastener changes, it should be retested. Normal testing using gas, should be at 150 PSI for Class 150 and 300 PSI for Class 300 valves from 1/2" through 6". It should be noted, however, that this test does not meet the requirements of ANSI, API, or MSS. For test procedures complying with these specifications, refer to the appropriate published specification or contact Flowserve.

FIGURE V A-10  
ASSEMBLED VALVE

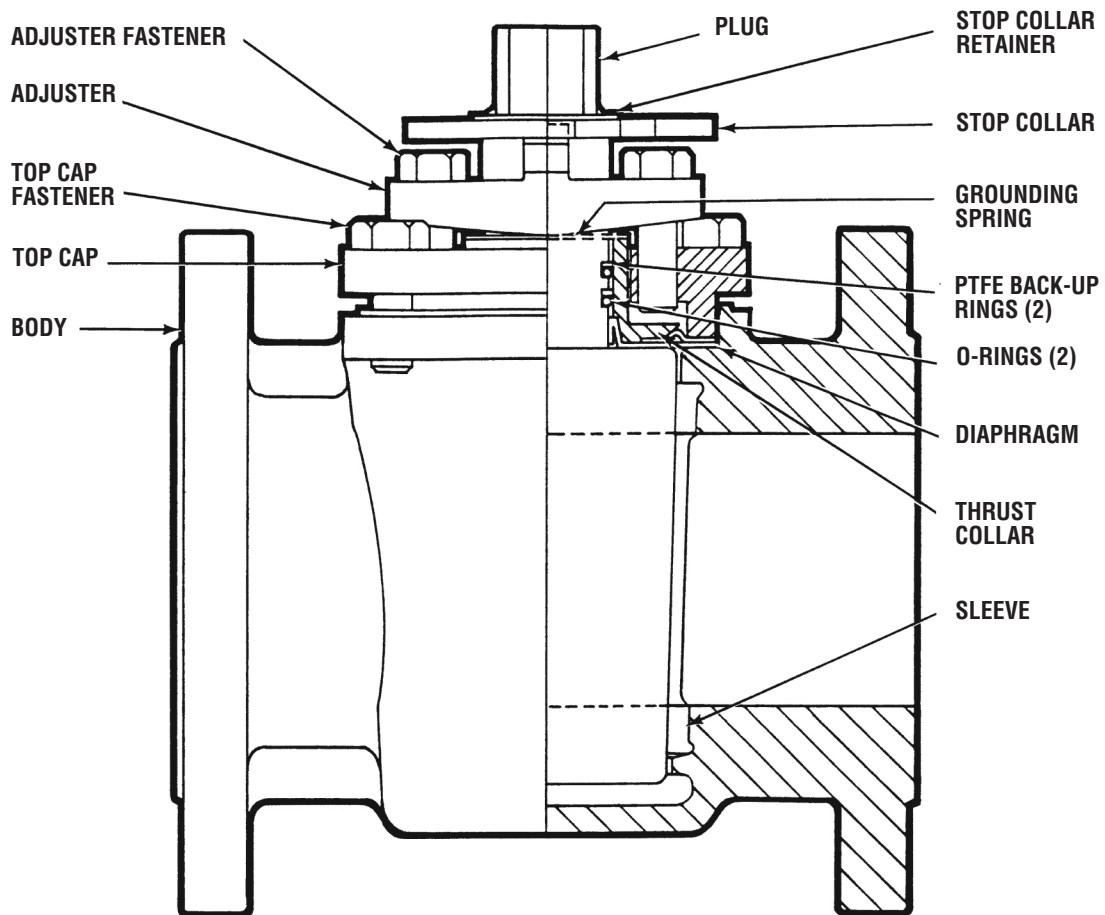

**SECTION V**

**B. VALVE ASSEMBLY – 1"-8" G4 MARATHON, G4R MARATHON**

Due to the tooling and associated equipment required (presses, fixtures, etc.) to rebuild 10"-14" size valves, it is highly recommended they be returned to the factory or a Flowserve Authorized Black Tie Valve Rebuilder for repair and rebuild. Many valves made by Flowserve Corporation handle corrosive chemicals which may be injurious to property or personnel. Valves returned without proper attention given to the safety requirements will be shipped back to the consignor collect.

NOTE: Part number reference is shown in Figure V B-9.

1. Apply Durco Seal 1028B to the inside of the tapered bore in the body and permit to dry before assembly. RAD-1 material is used for nuclear applications.
2. Apply a light coating of oil or silicone to the interior of the coining die or to the O.D. of the sleeve. Position the sleeve in the coining die, part series #BY79542A, so that the diagonal opposite sides of the sleeve port will lock behind the metal lips in the body (Figure V B-2). The sleeve is then pushed directly through the coining die into the valve body until the sleeve drops below the top counterbore of the valve body (Figure V B-1).

**FIGURE V B-1**

Push sleeve directly through coining die until sleeve drops below top counterbore of the valve body.

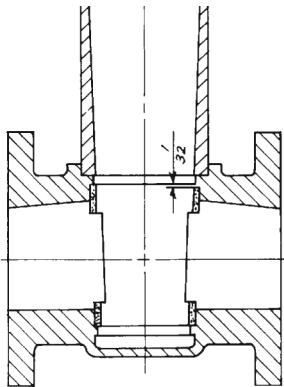

3. A special plug, part series #BY79664A, containing retractable or removable blades is lowered into the body with the blades retracted or removed. The blades are then installed or extended and a counter clockwise rotary motion is applied to the plug engaging the two remaining diagonal opposite sleeve port openings and pulling them until they fall behind the body port

**FIGURE V B-2**

A special plug with retractable or removable blades engages the two remaining sleeve ports and pulls them until they fall behind the body port lips.

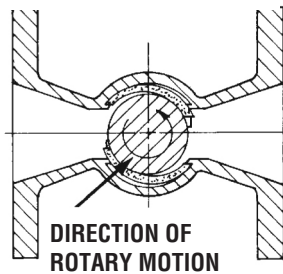

**FIGURE V B-2A**  
**Optional assembly operation for 1" & 1 1/2" G-4 Valves**

Care must be exercised to ensure that the bar does not slip and gouge or tear the sleeve.

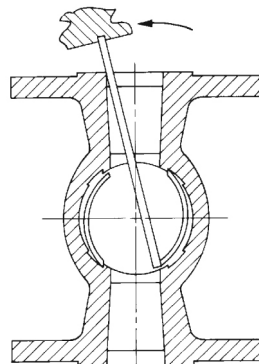

lips. The plug is then rotated back to its original position, and the blades are then removed or retracted. The plug is then removed from the body (Figure V B-2). In the 1" and 1 1/2" sizes, a bar may be substituted for the locking plug. See Figure V B-2A for a description of this operation.

**FIGURE V B-3**

The sizing plug is pushed into the sleeve until the sizing plug flange bottoms against the counterbore of the valve body.

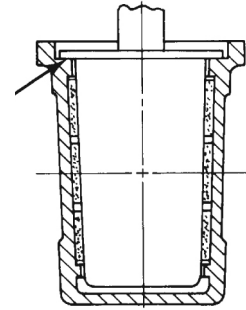

4. Apply a thin film of silicone lubricant on the sizing plug, part series #BY79555A, and push it into the sleeve until the sizing plug flange bottoms against the counterbore of the valve body (Figure V B-3). Allow the sizing plug to remain in this position for one minute.
5. Check that the inner diameter of the gasket pad of the top cap has between a 1/6" x 45° to 3/32" x 45° chamfer. If not, remachine the top cap to this dimension. See Figure V B-4.

**FIGURE V B-4**

**SET ADJUSTER CAP SCREWS TO MAKE ADJUSTER PARALLEL TO THE CAP**

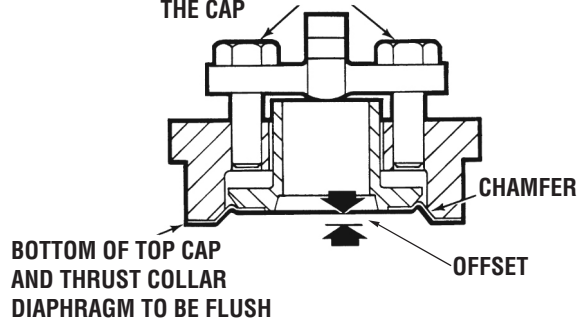

6. On a flat surface place the top cap and adjuster sub-assembly over the thrust collar. Thread the fasteners until snug.
7. The plug stem and diaphragm guide should be checked for nicks before installing the diaphragm. Nicks on these surfaces could result in scratches on the lip of the diaphragm. The diaphragm (Part 6) is assembled over the plug stem with the aid of the G4 diaphragm guide, part series #BY86272A (Figure V B-5).

**FIGURE V B-5**

If damaged the plug taper and 1" in length of stem must be polished to a surface finish of 16 on the taper and stem.

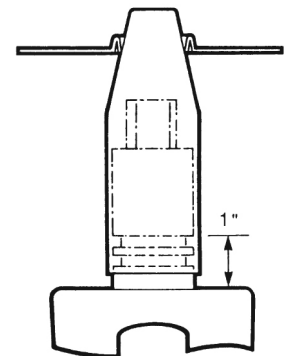

**SECTION V**

**B. VALVE ASSEMBLY – 1" & 8" G4 MARATHON, G4R MARATHON**

- 8. Using the diaphragm guide to protect the o-ring from the stem edge, install the first o-ring by "rolling" it with your fingers over the guide and into the lower stem groove (Figure V B-6). Install PTFE split ring in a similar manner such that it is located above the o-ring inside the lower groove. See Figure V B-7.

**FIGURE V B-6**

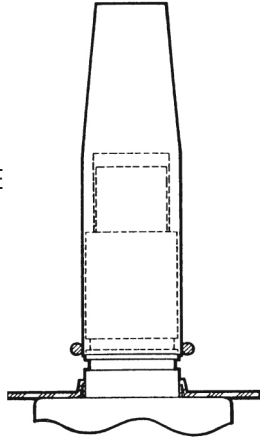

- 9. Install second o-ring and split ring in upper groove in a similar manner, except that the diaphragm guide should be raised by hand so that the lower edge of the guide does not contact the lower o-ring assembly. See Figure V B-7. Coat both o-ring assemblies liberally with Krytox® grease. Remove the guide.

**FIGURE V B-7**

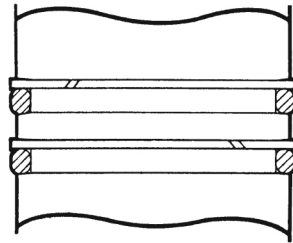

- 10. Place the thrust collar/diaphragm over the plug stem and gently maneuver it over the o-rings onto the PFA diaphragm. The thrust collar is driven into place through the use of the thrust collar guide, part series #BY86273A, and an arbor press (Figure V B-8).

**FIGURE V B-8**

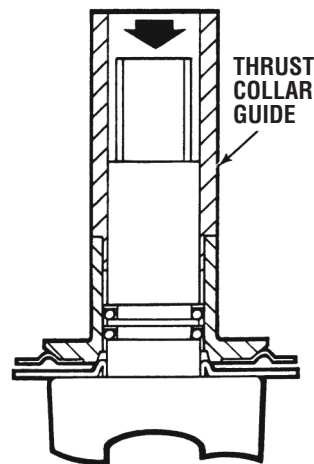

- 11. Place the grounding spring (Part 17) over the plug stem.
- 12. Apply a thin, even coat of silicone on the entire surface of the 2° plug taper.

- 13. Place the top cap and adjuster over the plug stem. Place this subassembly into the valve body. Using an arbor or hydraulic press, push down on the top cap evenly until the top cap gasket pad seats firmly against the body counterbore. Part series AY97223A should be used to push the top cap. Apply thread locking compound to the threads of the top cap fasteners. Tighten the top cap

fasteners to the torque values found in Torque Table #1a & #2b on page 12.

- 14. Remove the valve from the arbor press, loosen the adjuster fasteners, and operate the plug several times. It will turn hard at first but will then loosen and turn freely.
- 15. Tighten the adjuster fasteners (Part 12A) until a reasonable turning torque (Ref. Table #2) is obtained. The 8" and larger valves are placed in an oven at 200°F for a minimum of six hours prior to final adjustment with the plug in the open position. After removal from the oven and valve has cooled, loosen the adjuster fasteners. Turn the plug several times. Retighten the adjuster fasteners until a reasonable plug turning torque is obtained. Retighten the top cap fasteners. The height of the plug port should be positioned approximately 1/16" above to flush with the body port.
- 16. Place the stop collar (Part 19A) and retainer on the plug stem. The stop collar should point in the direction of flow.
- 17. The valve is now ready for test and use.
- 18. LEAK TESTING: Anytime a valve has been modified in any manner, including fastener changes, it should be retested. Normal testing using gas, should be at 150 PSI for Class 150 and 300 PSI for Class 300 valves from 1/2" through 6". It should be noted, however, that this test does not meet the requirements of ANSI, API or MSS. For test procedures complying with these specifications, refer to the appropriate published specification or contact Flowserve.

**FIGURE V B-9  
ASSEMBLED G4 MARATHON OR G4R MARATHON VALVE**

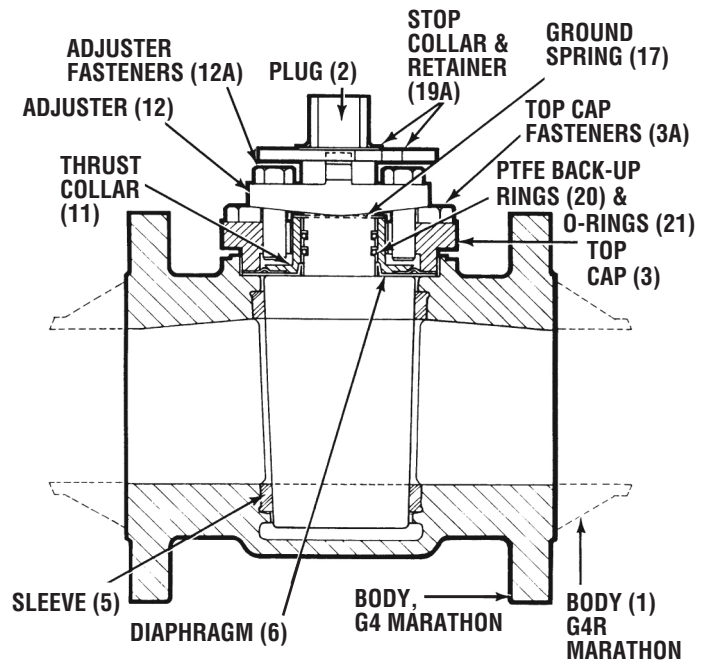

## SECTION V

### B. VALVE ASSEMBLY – 1"-8" G4 MARATHON, G4R MARATHON

**Table #1a** \*Apply Loctite® 242 to fastener threads, top cap only.  
**Torque Required On Top Cap Fasteners Of Class 150 G4 Marathon Valves**

| VALVE SIZE           | 1/2-3/4" | 1" | 1 1/2" | 2" | 3" | 4" | 6" | 8" | 8N  |
|----------------------|----------|----|--------|----|----|----|----|----|-----|
| MAX. TORQUE (FT-LBS) | 7        | 7  | 7      | 12 | 21 | 31 | 62 | 62 | 105 |

**Table #1b** \*Apply Loctite® 242 to fastener threads, top cap only.  
**Torque Required On Top Cap Fasteners Of Class 300 G4 Marathon Valves**

| VALVE SIZE           | 1/2-3/4" | 1" | 1 1/2" | 2" | 3" | 4" | 6"  | 8"  |
|----------------------|----------|----|--------|----|----|----|-----|-----|
| MAX. TORQUE (FT-LBS) | 7        | 13 | 13     | 20 | 31 | 62 | 125 | 115 |

**Table #2**  
**Torque On Plug Adjusters Of G4 Marathon Valves, 150# And 300#**

| VALVE SIZE             | 1/2-3/4" | 1" | 1 1/2" | 2" | 3" | 4" | 6"  | 8"  | 8N  |
|------------------------|----------|----|--------|----|----|----|-----|-----|-----|
| MAX. TORQUE (INCH-LBS) | 10       | 35 | 35     | 35 | 50 | 80 | 180 | 372 | 480 |

Loctite® is a registered trademark of the Loctite Corp.

**SECTION VI**

**ASSEMBLY SPECIFICATIONS – FIRESAFE VALVES G4Z MARATHON, G4ZR MARATHON**

**FIGURE VI-1**  
TYPICAL ASSEMBLY OF G4Z MARATHON AND G4ZHF MARATHON

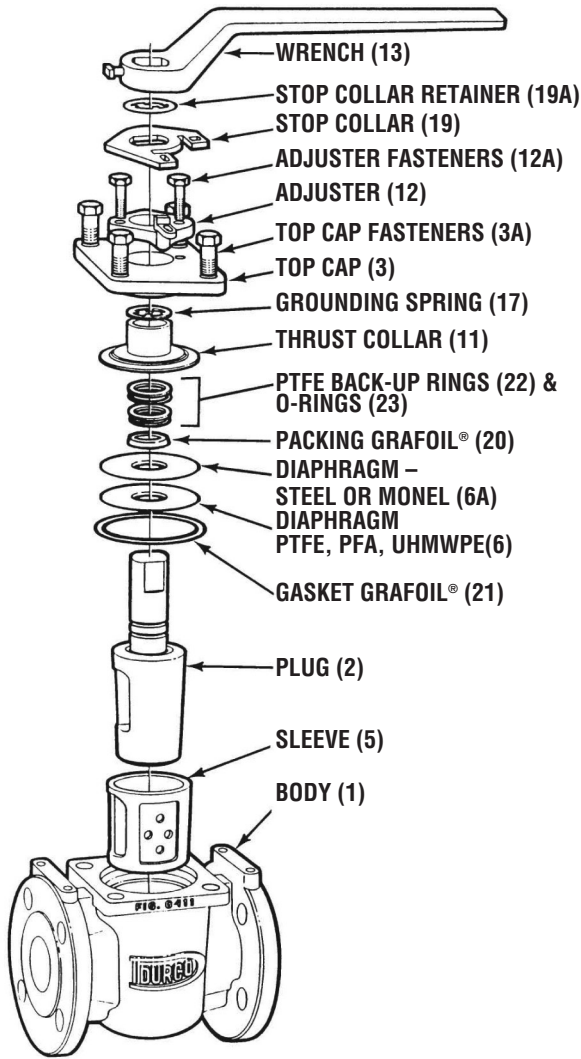

®Grafoil is a registered trademark of Union Carbide Corporation.

1/2"-4"

1. Normal procedures for field replacement of one piece sleeves are to be followed for inserting the sleeve, Section V A (1/2" & 3/4"), steps 1-3 or Section V B (1"-8"), steps 1-4.
2. Check that the inner diameter of the gasket pad of the top cap has between a 1/16" x 45° to 3/32" x 45° chamfer. If not, remachine the top cap of this dimension. See Figure V B-4, page 10.

3. The firesafe top seal assembly differs from the standard G4 top seal and is completed per the following instructions.
4. The PFA diaphragm (Part 6) is to be flared on a diaphragm guide just enough to slip over the plug stem (Figure VI-1A.)
5. The plug stem should be checked for nicks before installing the PFA diaphragm. Nicks on this surface could result in scratches on the lip of the diaphragm. The PFA diaphragm (Part 6) is placed over the plug stem with the aid of the G4 Marathon diaphragm guide part series BY86272A. The lip is down (Figure VI-2). Remove the guide.
6. The metal diaphragm (Part 6A) is placed over the plug stem and the hole enlarged just enough to slip down on the stem (Figure VI-3).
7. The metal diaphragm is then removed and replaced with the lip down (Figure VI-4).
8. The Grafoil packing ring (part 20) is placed over the stem (Figure VI-5).
9. Using diaphragm guide port # series P/N BY86272A to protect the o-ring from the stem edge, install the first o-ring by "rolling" it with your fingers over the guide and into the lower stem groove (Figure VI-6).

Install PTFE split ring in a similar manner such that it is located above the o-ring inside the lower groove. See Figure VI-7.

**FIGURE VI-1A**

Flare PFA diaphragm over tapered bar.

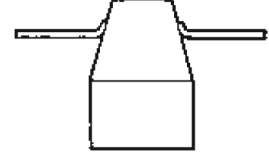

**FIGURE VI-2**

Place PFA diaphragm over plug stem with lip down.

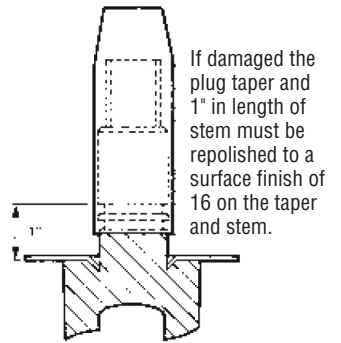

**FIGURE VI-3**

Flare metal diaphragm over plug stem with lip up.

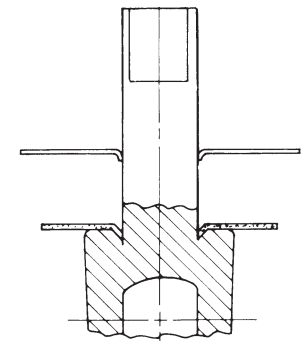

**FIGURE VI-4**

Metal diaphragm is removed and reassembled with lip down.

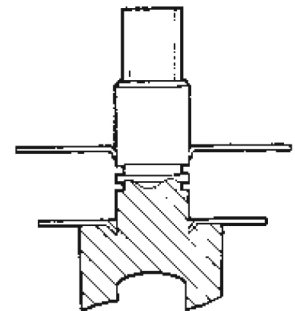

## SECTION VI

### ASSEMBLY SPECIFICATIONS – FIRESAFE VALVES G4Z, G4ZHF, G4ZR

10. Install second o-ring and split ring in upper groove in a similar manner, except that the diaphragm guide should be raised by hand so that the lower edge of the guide does not contact the lower o-ring assembly. See Figure VI-7. Coat both o-ring assemblies liberally with Krytox® grease. Remove the guide.

**FIGURE VI-5**

Grafoil packing ring placed over stem

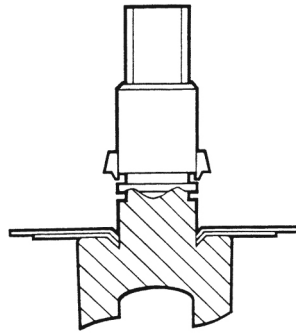

11. Place the thrust collar/diaphragm over the plug stem and gently maneuver it over the o-rings onto the Grafoil ring. The thrust collar (Part 11) is driven into place through the use of the thrust collar guide, part series #BY86273A, and arbor press (Figure VI-8).

**FIGURE VI-6**

O-Ring placed over stem.

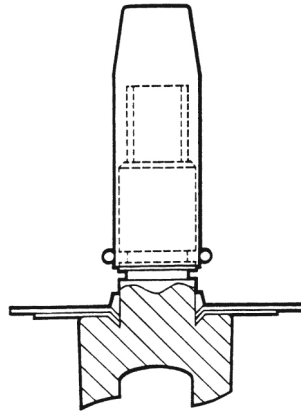

12. The Grafoil gasket is placed into the valve body counterbore. Check to make sure it is even with the bore.

**FIGURE VI-7**

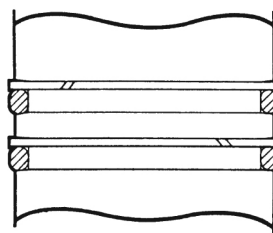

13. Continue to assemble the valve per Step 9 of Section V A for the 1/2" - 3/4" size valves and Step 11, Section V B for the 1" - 4".

**6"-8"-8"N** Due to the tooling and associated equipment required (presses, fixtures, etc.) to handle 10"-14" size valves, it is highly recommended they be returned to the factory for repair and rebuild.

**FIGURE VI-8**

Packing and thrust collar driven into place.

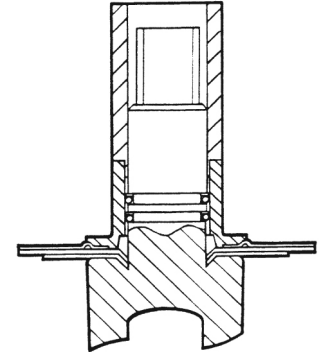

1. Normal procedures for field replacement of one piece sleeves are to be followed for inserting the sleeve Section V B, steps 1-4.
2. The firesafe top seal assembly differs from the standard G4 top seal and is completed per the following instructions.
3. The PFA diaphragm (Part 6) is to be flared on the diaphragm guide just enough to slip over the plug stem (Figure VI-1).
4. The plug stem and diaphragm guide should be checked for nicks before installing the PFA diaphragm. Nicks on this surface could result in scratches on the lip of the diaphragm. The PFA diaphragm is placed over the diaphragm guide with the lip down (Figure VI-2). Remove the guide.
5. The thrust collar (Part 11) and thrust collar guide, part series #BY86273A, are to be installed over the plug stem and loaded by an arbor press to flatten the PFA firesafe diaphragm. Remove the thrust collar and thrust collar guide.
6. The metal diaphragm is placed over the plug stem and the hole enlarged just enough to slip down on the stem. (Figure VI-3).
7. A thin coat of silicone oil is applied to the down edge of the metal diaphragm. The diaphragm is then placed over the plug stem with the lip down (Figure VI-4).

## SECTION VI

### ASSEMBLY SPECIFICATIONS – FIRESAFE VALVES G4Z, G4ZHF, G4ZR

8. The Grafoil packing ring (Part 20) is placed over the stem (Figure VI-5).
9. Using the diaphragm guide P/N BY86272A to protect the o-ring from the stem edge, install the first o-ring by “rolling” it with your fingers over the guide and into the lower stem groove (Figure VI-6). Install PTFE split ring in a similar manner such that it is located above the o-ring inside the lower groove. See Figure VI-7.
10. Install second o-ring and split ring in upper groove in a similar manner, except that the diaphragm guide should be raised by hand so that the lower edge of the guide does not contact the lower o-ring assembly. See Figure VI-7. Coat both o-ring assemblies liberally with Krytox grease.
11. Place the thrust collar/diaphragm over the plug stem and gently maneuver it over the o-rings onto the Grafoil ring. The thrust collar (Part 11) is then driven into place through the use of the thrust collar guide part # series BY86273A and arbor press (Figure VI-8).
12. The Grafoil top cap gasket (Part 21) is to be installed with the tapered or small edge diameter down or placed against the valve counterbore. The plug is pushed down until it is flush with the bottom of the body port in order to check the diaphragm fit inside the Grafoil gasket for clearance. The PFA diaphragm must not ride on the Grafoil gasket but should fit just inside the Grafoil.
13. The adjuster fasteners must be preset per Section VB-6. Check that the inner diameter of the gasket pad of the top cap has between a  $\frac{1}{16}$ " x 45° to  $\frac{3}{32}$ " x 45° chamfer. If not, remachine the top cap to this dimension. The thrust collar assembly (Part 3) and top cap (bonnet) are installed. The top cap must be checked before installation to ensure there is no chamfer on outside edge of the cap.
14. The top cap is visually located to be evenly spaced inside the body counterbore. The side of the top cap compression flange is equally spaced with the side wall of the body counterbore. Fasteners should be installed and tightened to 5 ft-lb torque to prevent movement of the cap during initial torquing. *Push down on the top cap evenly* until the top cap gasket pad seats firmly against the body counterbore. Part series AY97223A should be used to push down the top cap.
15. Once it has been determined that the gaskets fit properly, continue to tighten the top cap fasteners in 50 ft-lb increments in a crisscross fashion to the levels found in Table #1a & 1b, page 12.

Note: All fastening torques are for thread locker coated, corrosion free fasteners and nuts. Extreme care must be taken to prevent overstressing fasteners and subsequent valve parts by tightening in excess of industry standards for appropriate size and alloy fasteners. Ref. Torque Table #1a & 1b.

16. The adjuster fasteners (Part 12A) are loosened and the plug is turned a minimum of three times. The sleeve is checked on all four seal zones for tears.
17. With the plug in the open position, adjuster fasteners (Part 12A) are then torqued to the following levels or until the plug port is  $\frac{1}{8}$ " above or flush with body port: Ref. Table #2, page 12.

| Size | Torque    |
|------|-----------|
| 6"   | 180 in-lb |
| 8"   | 372 in-lb |
| 8N   | 480 in-lb |

18. Operate the plug a minimum of three times. The valve should look similar to Figure VI-9.
19. The gear box or actuator is installed with the plug set in the open position and the open position adjusting screw of the gear is then locked. Careful attention is required to set the gear box stop screw at 90° rotation for the closed position. A protractor may be used to check for 90° rotation or alignment scribes may be noted on the gear box cover.
20. LEAK TESTING: Anytime a valve has been modified in any manner, including fastener changes, it should be retested. Normal testing using gas, should be at 150 PSI for Class 150 and 300 PSI for Class 300 valves from  $\frac{1}{2}$ " through 6". It should be noted, however, that this test does not meet the requirements of ANSI, API or MSS. For test procedures complying with these specifications, refer to the appropriate published specification or contact Flowserve.

FIGURE VI-9  
ASSEMBLED G4Z MARATHON & G4ZHF MARATHON

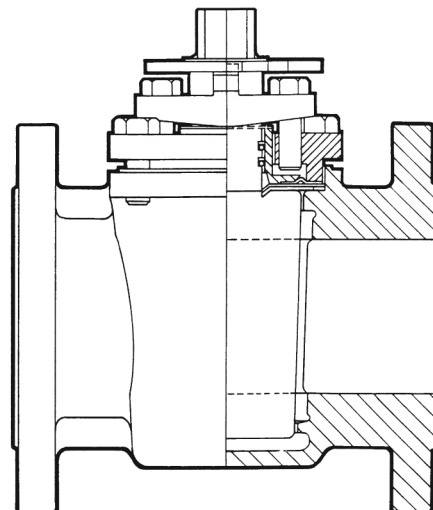

## SECTION VII

### RECOMMENDED SPARE PARTS

Named parts shown below by respective valve are recommended spare parts for that valve model.

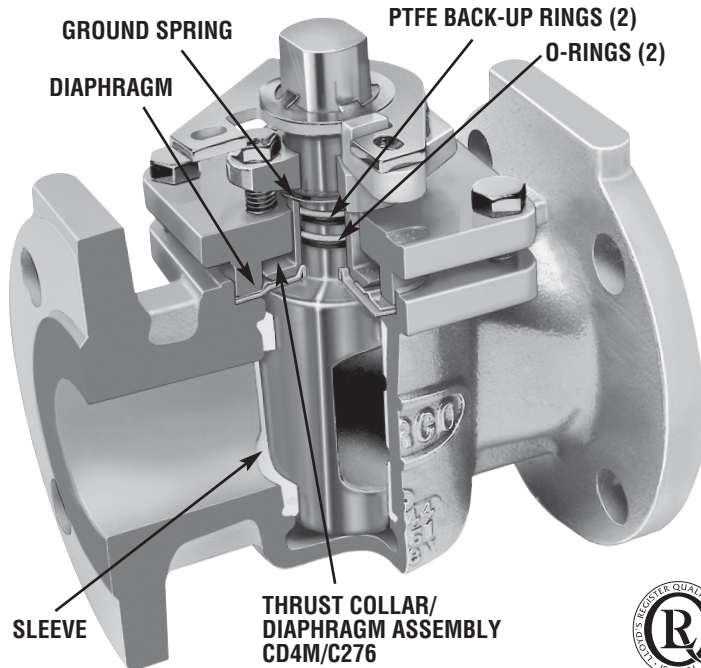

**G4 MARATHON VALVE**

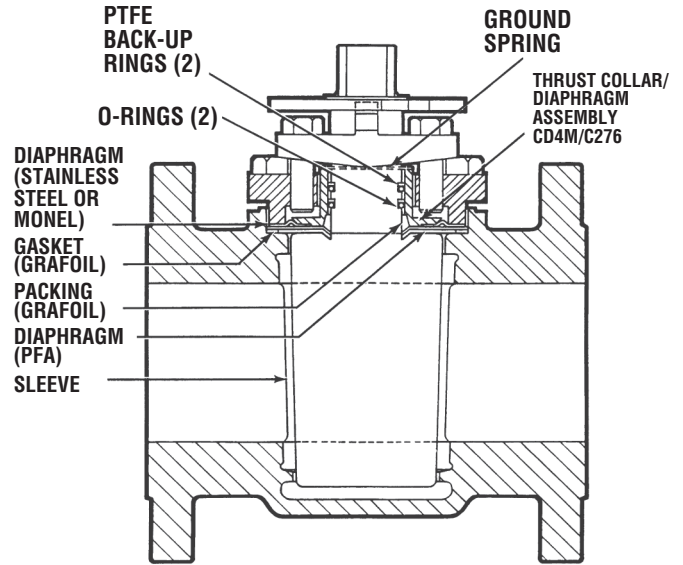

**G4Z & G4ZH FIREPROOF VALVE**



*Design, Manufacture, and In-house Repair  
of Ball, Butterfly and Plug Valves  
in Cookeville, TN*

#### **Selection, Installation, Operation and Maintenance**

Flowserve Corporation has established industry leadership in the design and manufacture of its products. When properly selected, each product is designed to perform its intended function safely during its useful service life. However, it is necessary that Flowserve's customers be fully aware of their responsibilities when using these products.

Each Flowserve valve product may be used in numerous applications under a wide variety of industrial service conditions. Although Flowserve can, and often does, provide general guidelines, it is obviously not possible to provide application specific data and warnings for all conceivable applications. The purchaser/end user must therefore assume the ultimate responsibility for the proper selection, installation, operation and maintenance of the products. Read the appropriate IOM before installation, operating or repairing any valve. The purchaser/end user should train its employees and/or contractors in the safe use of the Flowserve products in connection with the purchaser's manufacturing processes.

Flowserve will continue to provide its customers with the best possible products and service available. We do not recommend substituting surplus or remanufactured valves over new Durco valves or those repaired in an authorized service center. Should you have any questions about these provisions or about Flowserve's products in general, please contact your local Flowserve valve representative, who will be happy to help.

*Or Consult Your Local Stocking Distributor*

*For more information, contact:*

Flowserve Corporation  
Flow Control Division  
1978 Foreman Drive  
Cookeville, Tennessee 38501  
Phone: 931 432 4021  
Fax: 931 432 3105  
www.flowserve.com

Flowserve Ahaus GmbH  
Von Braun Straße 19a  
D-48683 Ahaus  
Germany  
Phone: +49 2561 686-0  
Fax: +49 2561 686-39

Flowserve Pte. Ltd.  
12 Tuas Avenue 20  
Republic of Singapore 638824  
Phone: 65-862-3332  
Fax: 65 862 2800

FCD DVENIM0270-07  
(Bulletin V-270)  
July 2013

© 2013 Flowserve Corporation