

Resin Aviator™

Mechanical Installation

Installation is best performed with our NAMUR mounting kits. These kits allow direct mounting of the Resin Aviator™ shaft to the actuator pinion without a coupler. NAMUR mounting kits will work with any actuator conforming to the NAMUR standard for accessory mounting hole locations and pinion dimensions. Simply attach bracket to actuator and Resin Aviator™ to bracket with the included fasteners. The Resin Aviator™ shaft features an integral alignment pin which engages the tapped pinion hole. Automax also offers a full line of non-NAMUR kits.

Electrical Connections

The Resin Aviator™ features one (1) 1/2" NPT conduit entry. The switches and pilot solenoid are pre-wired to a terminal strip to simplify customer wiring connections. A wiring diagram is included under the lid. Simply make desired connections to the pre-wired screw terminal block. Secure a grounding wire under the green grounding screw. Make sure the solenoid control voltage is the same as the solenoid electrical rating. For hazardous locations, U.L. and National Electric codes require an approved sealing fitting within 18 inches of the switch enclosure. Sealing fittings are not required for Division 2 non-incendive applications. Open conduit entries must be closed after installation using a close-up plug approved for hazardous locations. Conduit and plugs must engage a full five (5) threads.

Caution:
To prevent ignition of hazardous atmospheres, keep all cover bolts tight WHILE CIRCUITS are live. Disconnect supply circuit before opening.

Spool and Tubing Configuration

1. For spring return actuators, a 4-way spool valve is provided with port #2 plugged. For double acting actuators, the same valve is provided with no plugs. Make sure the correct spool is selected before installing tubing. (Note: the APS2 module can be supplied on spring return actuators to purge the spring chamber with supply air.)
2. Make sure all air pressure is removed before installing tubing.
3. Attach tubing according to Figures 1 or 2 below, depending upon application. Attach supply tubing to Port 1 and use Ports 3 and 5 for exhaust.
4. To prolong actuator life use only clean, dry plant air. Lubricated air is not required, although it is recommended particularly for high cycle applications.

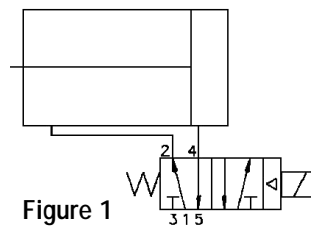

Figure 1

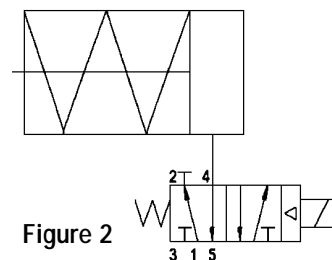

Figure 2

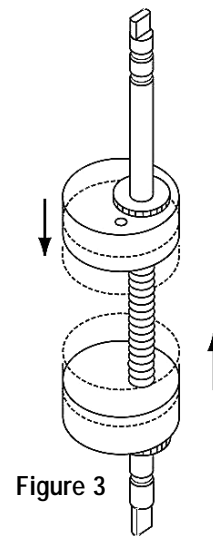

Figure 3

Switch Setting

1. Rotate actuator to desired position.
2. Loosen five captive cover screws and remove lid, turning slightly while lifting.
3. To adjust the limits, lift or depress cam against spring to disengage splines and turn cam until switch activates/deactivates as desired (Figure 3).
4. Release cam, assuring that the splines are engaged.
5. Clean base and lid flanges and replace lid on base. Make sure wires are NOT caught between flanges, and tighten captive screws.

Lubrication

All Resin Aviator™ spool valves are pre-lubricated and will operate dry (with no additional lubrication). The use of lubricated air will not interfere with the Aviator's functioning. If air lubrication is used, the oils listed below are popular, easily obtainable fluids that are recommended

for use with the Resin Aviator™ Spool valve:
Gulf Harmony 47, Mobil DTE Medium, Shell Tellus 29, Texaco Rondo B, Sohivis 47 and Sunnis 921. Many other lubricants are acceptable providing they do not contain detergents that will attack Buna N or Viton Seals.

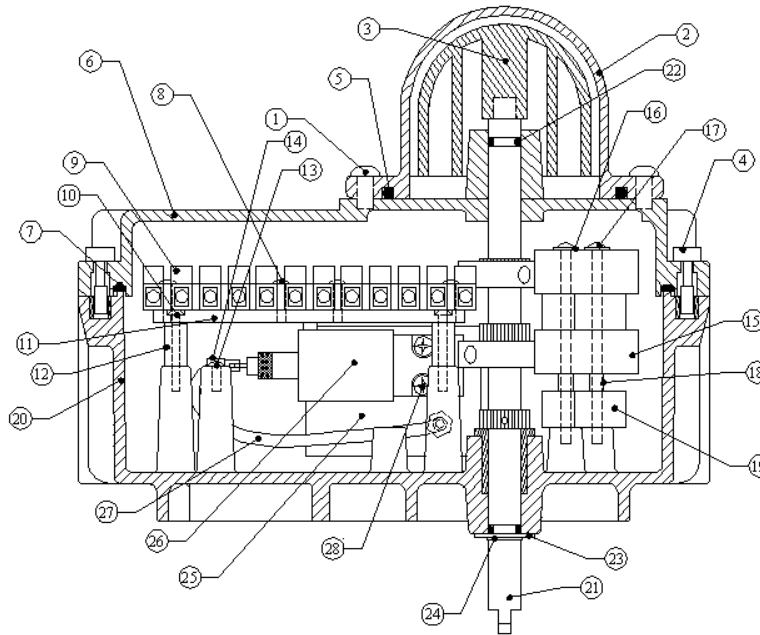

How to Specify

Part Numbers

NO.	ITEM	P/N	QTY
1	10-24 x 1/2 Phillips Head Screw	X00676	4
2	Ultra Dome	X00662	1
3	Rotor	X00663	1
4	10-24 Capture Screw	X00360	6
5	O-ring	X00677	1
6	Cover	XM0310	1
7	Gasket	X00981	1
8	4-40 x 1/2 Phillips Head Screw	X00318	4
9	Terminal Block, 12 Position	103683	1
10	4-40 x 1/2 Phillips Head Screw	100518	2
11	Bracket, Terminal Block	XM0063	1
12	Spacer, 0.68" High	104158	2
13	4-40 x 3/16 Ground Screw	104147	1
14	8-32 Ground Cup Washer	105626	1
20	Base	XM0311	1
21	Shaft Assembly	Varies	1
22	O-ring	103603	1
23	Washer	X00361	1
24	Snap Ring	101810	1

Switch Options

NO.	ITEM	P/N	QTY
15	Proximity Switch	Varies	2
16	4-40 Washer	X00425	2
17	4-40 x 2.25 Phillips Head Screw	106130	2
18	Spacer, 0.2" High	105679	2
19	Spacer	X00691	2
	SPDT Mechanical Switch	Varies	2
	4-40 x 1.125 Phillips Head Screw	100159	2
	Insulator	103675	2
	Spacer, 0.2" High	105679	2
	DPDT Mechanical Switch	103628	2
	4-40 x 1.125 Phillips Head Screw	100159	2
	Insulator	103675	2

Solenoid Options

NO.	ITEM	P/N	QTY
25	Manifold, 2 Watt Coil	Varies	1
26	2 Watt Coil	Varies	1
27	1/8 Tubing	X00837	1
28	4-40 x 1 Phillips Head Screw	100158	2
	Manifold, 0.67 Watt Coil	Varies	1
	0.67 Watt Coil	Varies	1
	1/8 Tubing	X00837	1

Spool Valve Options (Not Shown)

NO.	ITEM	P/N	QTY
	Spool Valve	Varies	1
	O-ring	X01039	Varies
	10-32 x 1.5 Socket Head Screw	X00784	3
	Muffler	Varies	2