

Installation, Operation, Maintenance Instructions

Pneumatic Diaphragm On-Off Actuators

Series 3, Type: P7

Index	
1	Using Kämmer valves and actuators correctly.
2	Unpacking
3	Installation
4	Quick check
5	Maintenance
6	Remove and install actuator
7	Disassemble and assemble actuator
8	Troubleshooting chart

1 USING KÄMMER VALVES AND ACTUATORS CORRECTLY

1.1 General

The following instructions are designed to assist in unpacking, installing and performing maintenance as required on Kämmer products. Product users and maintenance personnel should thoroughly review this bulletin prior to installing, operating or performing any maintenance.



DANGER: *In most cases Kämmer valves and actuators are designed for specific applications (e.g. with regard to medium, pressure, temperature). For this reason they should not be used in other applications without first contacting the manufacturer.*

1.2 Terms concerning safety

The safety terms **DANGER**, **WARNING**, **CAUTION** and **NOTE** are used in these instructions to highlight particular dangers and/or to provide additional information on aspects that may not be readily apparent.



DANGER: *indicates that death, severe personal injury and/or substantial property damage will occur if proper precautions are not taken.*



WARNING: *indicates that death, severe personal injury and/or substantial property damage can occur if proper precautions are not taken.*



CAUTION: *indicates that minor personal injury and/or property damage can occur if proper precautions are not taken.*



NOTE: *indicates and provides additional technical information, which may not be very obvious even to qualified personnel. Compliance with other, not particularly emphasised notes, with regard to transport, assembly, operation and maintenance and with regard to technical documentation (e.g. in the operating instruction, product documentation or on the product itself) is essential, in order to avoid faults, which in themselves might directly or indirectly cause severe personal injury or property damage.*

1.3 Protective clothing

Kämmer products are often used in problematic applications (e.g. extremely high pressures, dangerous, toxic or corrosive mediums). In particular valves with bellows seals point to such applications. When performing service, inspection or repair operations always ensure, that the valve and actuator are depressurised and that the valve has been cleaned and is free from harmful substances. In such cases pay particular attention to personal protection (protective clothing, gloves, glasses etc.).

1.4 Qualified personnel

Qualified personnel are people who, on account of their training, experience and instruction and their knowledge of relevant standards, specifications, accident prevention regulations and operating conditions, have been authorised by those responsible for the safety of the plant to perform the necessary work and who can recognise and avoid possible dangers.

1.5 Installation

DANGER: *Before installation check the order-no, serial-no. and/or the tag-no. to ensure that the valve/actuator is correct for the intended application.*



Do not insulate extensions that are provided for hot or cold services.

Pipelines must be correctly aligned to ensure that the valve is not fitted under tension.

1.6 Spare parts

Use only Kämmer original spare parts. Kämmer cannot accept responsibility for any damages that occur from using spare parts or fastening materials from other manufactures. If Kämmer products (especially sealing materials) have been on store for longer periods check these for corrosion or deterioration before using these products. Fire protection for Kämmer products must be provided by the end user.

1.7 Service / repair

To avoid possible injury to personnel or damage to products, safety terms must be strictly adhered to. Modifying this product, substituting nonfactory parts, or using maintenance procedures other than outlined in this instruction could drastically affect performance and be hazardous to personnel and equipment, and may void existing warranties. Between actuator and valve there are moving parts. To avoid injury Flowserve provides pinch-point-protection in the form of cover plates, especially where side-mounted positioners are fitted. If these plates are removed for inspection, service or repair special attention is required. After completing work the cover plates must be refitted.

Apart from the operating instructions and the obligatory accident prevention directives valid in the country of use, all recognised regulations for safety and good engineering practices must be followed.



WARNING: Before products are returned to Kämmer for repair or service Kämmer must be provided with a certificate which confirms that the product has been decontaminated and is clean. Kämmer will not accept deliveries if a certificate has not been provided (a form can be obtained from Kämmer).

1.8 Storage

In most cases Kämmer Products are manufactured from stainless steel. Products not manufactured from stainless steel are provided with an epoxy resin coating. This means that Kämmer products are well protected from corrosion. Nevertheless, Kämmer products must be stored adequately in a clean, dry environment. Plastic caps are fitted to protect the flange faces and to prevent the ingress of foreign materials. These caps should not be removed until the valve is actually mounted into the system.

1.9 Valve and actuator variations

These instructions cannot claim to cover all details of all possible product variations, nor in particular can they provide information for every possible example of installation, operation or maintenance. This means that the instructions normally include only the directions to be followed by qualified personal where the product is being used for is defined purpose. If there are any uncertainties in this respect particularly in the event of missing product-related information, clarification must be obtained via the appropriate FLOWSERVE sales office.

2 UNPACKING

2.1 Each delivery includes a packing slip. When unpacking, check all delivered valves and accessories using this packing slip.

2.2 Larger valves can be lifted using slings on the yoke rods or, if present, on the lugs provided for this purpose. If slings are used, attach them so that the outer tubing or attaching parts are not damaged.



WARNING: If slings are used, be aware that the centre of gravity of the valve may be above the lifting point. In this case, secure or support the valve against rotating, to prevent damage or personnel injury.

2.3 Report transport damage to the carrier immediately.

2.4 In case of discrepancies, contact your nearest FLOWSERVE sales office.

3 INSTALLATION

3.1 Clean tubing prior to installing.

3.2 If possible, install the valve in an upright position (actuator on top), to ease maintenance. An upright installation position is important with low-temperature applications, in order to keep the distance between the packing material and the medium as large as possible. The packing material then retains the ambient temperature as much as possible.



NOTE: Do not insulate extension bonnets that are provided for hot or cold services

3.3 Make sure that sufficient overhead clearance above the actuator is maintained, to allow for disassembly of plug from the valve body (see following table).

3.4 After installing, check direction of flow again. The direction of flow is shown by the arrow on the housing.

3.5 If the valve is to be welded into the line, make sure that the valve is shielded from excessive heat.

3.6 Connect supply pressure and signal lines. Control valves are supplied with a positioner. The end connections for supply pressure and signal are clearly marked. Series 4 actuators and positioners are suitable for max. 4.2 bar (60 psi) supply pressure. If the supply pressure exceeds the pressure specified on the nameplate, a pressure reducing station is required. If instrument air is not available, install an oil separator/air filter in the air inlet line. All connections must be leak free.

4 QUICK CHECK

Before operating, check the valve as follows:

- 4.1 Open and close the valve, and observe the movement of the actuator stem. The movement must be smooth and linear.
- 4.2 Check for maximum stroke through change of signal (for pneumatic positioners, 0.2 - 1.0 bar or corresponding split-range values; for IP positioners, 4-20 or 0-20 mA).
- 4.3 Check all air connections for leaks.
- 4.4 Tighten packing nut (see table 1).

Thread	Torque	
	PTFE	Grafoil
M20 x 1,5	1	3
M30 x 1,5	6	15
M38 x 1,5	15	35
M45 x 1,5	17	40

Table 1



NOTE: An excessively tightened gland nut can cause excessive packing wear and can hinder the free movement of the plug stem.

- 4.5 Check fail-safe position. To do this, close supply pressure and observe whether the valve opens or closes as defined.
- 4.6 After use at fluctuating temperatures, re-tighten all bolt connections and check for leaks.

5 MAINTENANCE

Check valves for correct functioning at regular intervals (at least once every 6 months) as follows. This check can be made when installed and in many cases without interrupting production. If internal defects are suspected, see section „Disassembly and Assembly of Valve“.

- 5.1 Examine gaskets for leaks and if necessary re-tighten bolts (see Fig. 1).
- 5.2 Check bellows gasket and test connection - if present - for external leaks.
- 5.3 Check valve for damage caused by corrosive residues or corrosive vapours.
- 5.4 Clean valves and repaint as necessary.



Warning: To prevent a buildup of electrostatic charge clean the actuator/valve with a damp cloth only.

- 5.5 Check gland nut for correct torque (see table 1).



NOTE: An excessively tightened gland nut can cause excessive packing wear and can hinder the free movement of the plug stem.

- 5.6 If possible, open and close valve and check for maximum stroke and smooth movement of the plug stem. Irregular movement of the plug stem may indicate internal defects.



NOTE: With graphite packing, irregular movement of the plug stem is normal.



WARNING: Keep hands, hair, clothing, etc. away from all moving parts. Failure to do so can lead to serious injury.

- 5.7 Check all accessories for firm seating.
- 5.8 If possible, close supply pressure and check the fail-safe position.
- 5.9 Check stem boot for wear.
- 5.10 Check actuator for leaks. To do this, spray housing, air connections and plug stem guide with leak spray and check for any bubble formation.
- 5.11 Clean plug stem.
- 5.12 Check air filter, if present, and if necessary replace insert.



NOTE: For further information regarding service and maintenance please contact your nearest FLOWSERVE office.



DANGER: On actuators with aluminium cases the actuator springs must be renewed with original spare parts every 10 years or after 50.000 operating hours which ever occurs first.

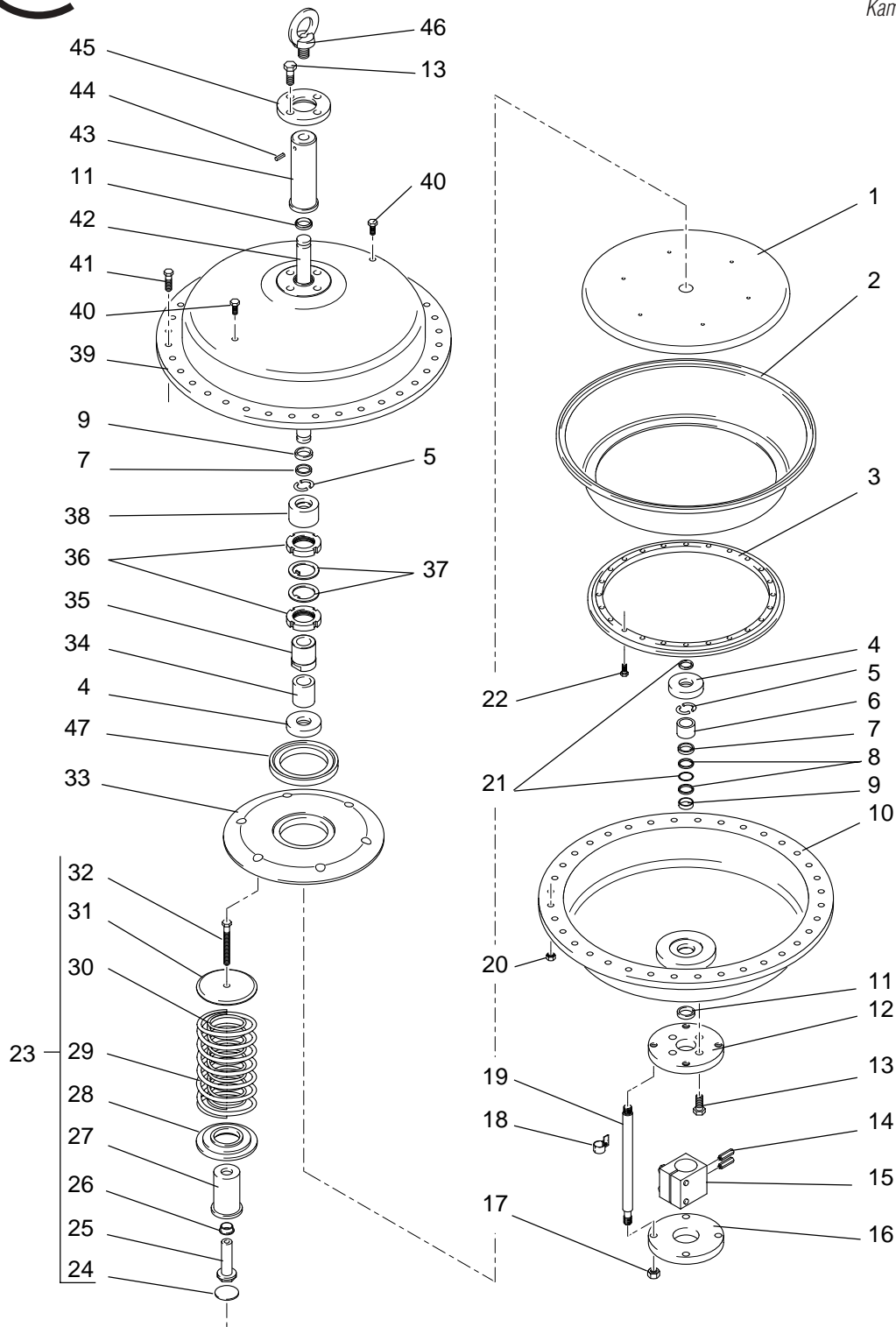

- | | | | | | |
|----|-------------------------|-------|-------------------------|----|------------------------|
| 1 | Diaphragm plate | 17 | Nut, M20 | 33 | Plate |
| 2 | Diaphragm | 18 | Travel indicator, assy. | 34 | Sleeve |
| 3 | Diaphragm ring | 19 | Yoke rod, 410 mm long | 35 | Adjusting sleeve |
| 4 | Plate | 20 | Nut, M16 | 36 | Slotted nut, M68 x 1,5 |
| 5 | Split ring | 21 | O-Ring | 37 | Locking plate |
| 6 | Sleeve | 22 | Screw, M12 x 30 | 38 | Sleeve |
| 7 | Ring | 23-32 | Spring set | 39 | Spring housing |
| 8 | Back-up ring | 24 | Washer | 40 | Vent plug |
| 9 | Bushing | 25 | Sleeve | 41 | Screw, M16 x 70 |
| 10 | Diaphragm housing | 26 | Bushing | 42 | Actuator stem |
| 11 | Wiper ring | 27 | Sleeve | 43 | Cap |
| 12 | Yoke plate, upper | 28 | Spring plate, lower | 44 | Grooved pin |
| 13 | Screw, M20 x 45 | 29 | Spring, external | 45 | Flange |
| 14 | Screw, NAMUR | 30 | Spring, internal | 46 | Eye bolt |
| 15 | Coupling, assy. M24 | 31 | Spring plate, upper | 47 | Pre-tension plate |
| 16 | Yoke plate, lower, Ø 75 | 32 | Screw, M16 x 140 | | |

Fig. 1: On - Off Actuator, Air-to-Open

Service to the actuator is best performed when the actuator is removed from the valve body. For the purpose of these instructions, consider the actuator as a separate subassembly with the procedures described in these instructions being performed in a designated workplace. However, many service repairs and adjustments can be accomplished in the field while the actuator and valve body are still connected to each other.

Attention: The valve trim is a very sensitive assembly, take care not to damage it. Always remove and replace the actuator together with the top yoke plate (12) and yoke rods (19).

6 REMOVE AND INSTALL ACTUATOR

6.1 REMOVE ACTUATOR

(refer to figs. 1 + 2)

6.1.1 Shut off the air supply.



WARNING: Depressurise the line to atmospheric pressure and drain all fluids from the valve before working on the actuator. Failure to do so can cause serious injury.

6.1.2 Remove the coupling (15) from the actuator stem (42):

Loosen clamping screws (50) and expand the clamping gap as required, apply air to the actuator to move the actuator stem around 5% from it's end position. Screw out the slotted nut (51) and drive the actuator stem out of the coupling (by applying more air on "Air-to-Open" or by venting air on "Air-to-Close"). Remove ring (52), split ring (53) and slotted nut (51).

6.1.3 Attach a crane to the eye bolt (46) to support the actuator and remove the nuts (17) from the yoke rods (19). Vent the actuator.



WARNING: When the actuator is vented on version "Air-to-Open" the actuator stem will extend and raise the actuator!

Remove any tubing and raise the actuator from the valve.

6.1.4 Loosen the coupling locknut and unscrew the coupling (15) from the plug stem.

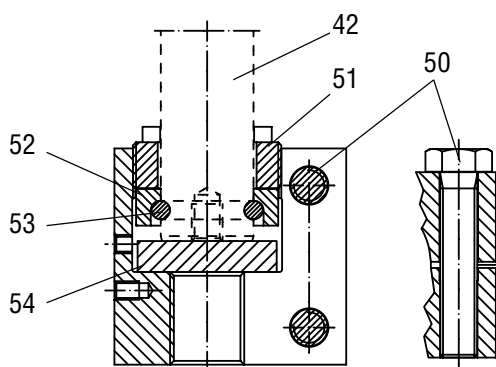

Fig. 2: Coupling

6.2 INSTALL ACTUATOR

(refer to Figs. 1 + 2)

6.2.1 Screw the coupling (15) onto the plug stem until the stem touches the thrust washer (54).

6.2.2 Mount the actuator onto the valve and secure the yoke rods (19) to the yoke plate (16) using the nuts (17). Connect an air supply to the actuator using a valve that can regulate the air to aerate and vent the actuator.

6.2.3 Fit the slotted nut (51), ring (52) and split rings to the actuator stem (on "Air-to-Open" versions retract the stem by applying air).

6.2.4 Carefully enter the actuator stem into the coupling and screw the slotted nut (51) into the coupling.

6.2.5 Screw the coupling anticlockwise onto the actuator stem to achieve a pretension of 2 to 4 mm ensuring that the NAMUR studs (14) are correctly positioned.



NOTE: Ensure that the plug assembly is not rotated with the plug seated. This may cause irreparable damage to the seating faces.

6.2.6 Tighten coupling locknut, slotted nut (51) and clamping screws (50).

6.2.7 As required reconnect all tubing.

7 DISASSEMBLE AND ASSEMBLE ACTUATOR

7.1 Disassemble actuator

7.1.1 Remove the 36 flange screws and nuts M16 (41/20) and lift off the spring housing (39).

7.1.2 Remove the pre-tension plate (47) (only for actuators with additional pre-tensioning), the spring plate (33) and the pre-tensioned spring packs (23).

7.1.3 Remove actuator stem complete with diaphragm (2) and diaphragm plate (1). Store with diaphragm facing upwards (be careful not to damage the diaphragm).

Disassemble diaphragm

7.1.4 Unscrew the 24 screws M12x30 (22) and lift off the diaphragm.

7.1.5 Reverse the assembly so that the adjusting sleeve (35) is facing upward.

7.1.6 Straighten the locking plates (37) and screw the slotted nuts down (clockwise) until the split ring (5) can be removed from the groove in the actuator stem (secure the actuator stem against falling through).

7.1.7 Remove sleeve (38), adjusting sleeve (35) complete with slotted nuts (36) and locking plates (37), Sleeve (34) and plate (4).

7.1.8 Remove the actuator stem (42) from the underside of the diaphragm housing (1) and remove the plate (4) and split ring (5).

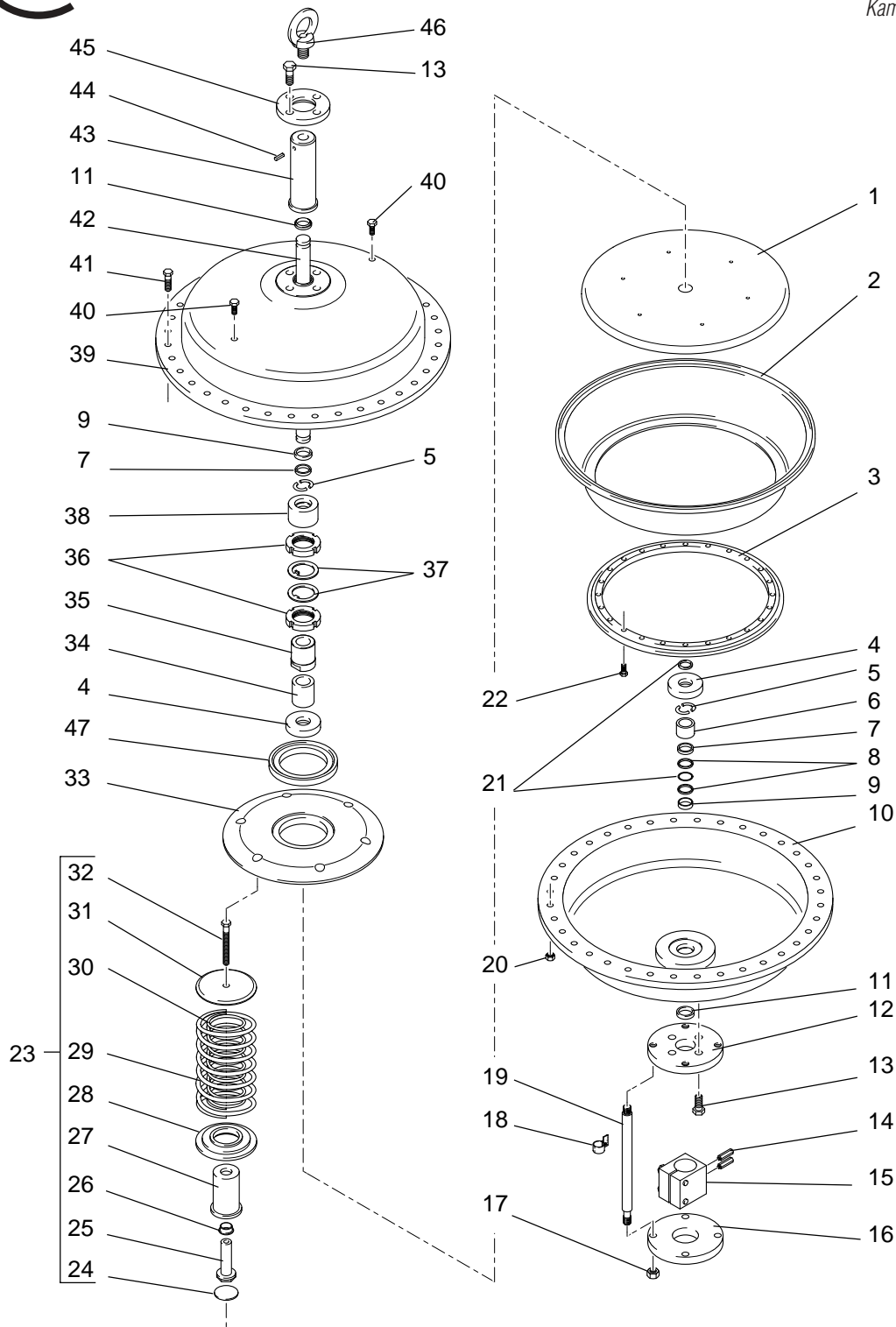

- | | | | | | |
|----|-------------------------|-------|-------------------------|----|-------------------------|
| 1 | Diaphragm plate | 17 | Nut, M20 | 33 | Plate |
| 2 | Diaphragm | 18 | Travel indicator, assy. | 34 | Adjusting sleeve |
| 3 | Diaphragm ring | 19 | Yoke rod, 410 mm long | 35 | Adjusting sleeve |
| 4 | Plate | 20 | Nut, M16 | 36 | ASlotted nut, M68 x 1,5 |
| 5 | Split ring | 21 | O-Ring | 37 | Locking plate |
| 6 | Sleeve | 22 | Screw, M12 x 30 | 38 | Sleeve |
| 7 | Ring | 23-32 | Spring set | 39 | Spring housing |
| 8 | Back-up ring | 24 | Washer | 40 | Vent plug |
| 9 | Bushing | 25 | Sleeve | 41 | Screw, M16 x 70 |
| 10 | Diaphragm housing | 26 | Bushing | 42 | Actuator stem |
| 11 | Wiper ring | 27 | Sleeve | 43 | Cap |
| 12 | Yoke plate, upper | 28 | Spring plate, lower | 44 | Grooved pin |
| 13 | Screw, M20 x 45 | 29 | Spring, external | 45 | Flange |
| 14 | Screw, NAMUR | 30 | Spring, internal. | 46 | Eye bolt |
| 15 | Coupling, assy. M24 | 31 | Spring plate, upper | 47 | Pre-tension plate |
| 16 | Yoke plate, lower, Ø 75 | 32 | Screw, M16 x 140 | | |

Fig. 1: On - Off Actuator, Air-to-Open

Disassemble actuator stem seal and guide

- 7.1.9 Remove calked ring (7).
- 7.1.10 Remove seal kit consisting of backup rings (8) and O-ring (21).
- 7.1.11 Remove wiper ring (11) and bushing (9).
- 7.1.12 Remove calked ring (7), bushing (9) and wiper ring (11) from Spring housing (39).

7.2 ASSEMBLE ACTUATOR

Assemble actuator stem seal and guide

- 7.2.1 Fit bushing (9) and wiper ring (11) to spring and diaphragm housings (10/39).
- 7.2.2 Enter backup ring (9), O-ring (21) and back up ring (9) from the other side of diaphragm housing.
- 7.2.3 Fit rings (7) to spring and diaphragm housings and calk in 4 positions with a punch.

Assemble actuator stem and diaphragm

- 7.2.4 Clamp the lower part of the actuator stem (42) in a vice (protect the stem against surface damage).
- 7.2.5 Fit split ring (5) to lower groove and replace plate (4) with O-ring (21).
- 7.2.6 Fit diaphragm plate (1), plate (4), sleeve (34) and adjusting sleeve (35) to actuator stem (42).
- 7.2.7 Screw two slotted nuts (36) with two locking plates (37) between them onto adjusting sleeve (35). Replace the sleeve (38) and screw down the slotted nuts until the split ring (5) can be fitted into the groove in the actuator stem.
- 7.2.8 Screw the top slotted nut (36) anticlockwise against the sleeve (38) until the diaphragm plate (1) is tightly clamped to the actuator stem (42). Secure the top slotted nut with the second slotted nut and in turn secure both nuts by bending the locking plates.

- 7.2.9 Reverse the assembly (diaphragm side upward); Replace the diaphragm (2) and diaphragm plate (3) and secure with 24 screws M12x30 (22) to the diaphragm plate (1) (torque value see table 2).

Assemble actuator

- 7.2.10 Place the sleeve (6) in the centre of the diaphragm housing (10).
- 7.2.11 Fit the actuator stem assembly to the diaphragm housing (10) ensuring that the outer bead of the diaphragm sits correctly
- 7.2.12 Replace the washer (24).
- 7.2.13 Place the spring packs (23) on the washers (24) .
- 7.2.14 Place the plate (33) over the spring packs (23).
- 7.2.15 Replace the spring housing assembly (39) with cap (43) and eye bolt (46) and secure with 36 screws/nuts M16 (41/20) (torque value see table 2).

7.3 Inspection

Function:

Conduct five open / close cycles and check for smooth operation.

Leakage:

Test pressure 6,6 bar (hold time 13 min).

Spray actuator stem entries and all housing joints with leak spray and check for leaks.

Fastner	Pos.	Torque value
Flange	41, 20	120 Nm
Diaphragm ring	22	60 Nm

Table 2: Torque values

8 Troubleshooting chart

Problem	Possible cause	Corrective Action
Stem pulsates	1. Unstable air supply 2. Vent or passage blocked	2. Adjust air supply 3. Clean vent or passage
Actuator slow	1. Air supply too low 2. Diaphragm case leaks air 3. Spring case vent blocked	1. Adjust air supply 2. Seal diaphragm case 3. Renew vent
Actuator will not return to end position	1. Air supply too low 2. Broken actuator spring 3. Actuator movement blocked	1. Adjust air supply 2. Renew all actuator springs 3. Dissassemble actuator and check
Actuator will not return to the failsafe position	1. Actuator not vented 2. Broken actuator spring 3. Actuator movement blocked	1. Vent actuator 2. Renew all actuator springs 3. Dissassemble actuator and check

Regional Headquarters

Flowserve
Manderscheidstr. 19
45141 Essen
Germany
Telephone: +49 (0) 201 8919 5
Facsimile: +49 (0) 201 8919 662

Flowserve
1350 N. Mt. Springs Prkwy.
Springville, UT 84663
USA
Telephone: +1 801 489 8611
Facsimile: +1 801 489 3719

Flowserve
12 Tuas Avenue 20
Singapore 638824
Telephone: +65 862 3332
Facsimile: +65 862 4940

Main Sales Offices (Europa, Middle east, Africa)

Flowserve
von-Braun-Straße 19a
48681 Ahaus
Germany
Telephone: +49 (0) 2561 6860
Facsimile: +49 (0) 2561 68648

Flowserve
12, av. du Québec
91965, Courtaboeuf Cedex
France
Telephone: +33 (0) 1 60 923 251
Facsimile: +33 (0) 1 60 923 299

Flowserve
Station Road
Persnore, Worcestershire
England WR102BZ
Telephone: +44 (0) 1386 55 45 51
Facsimile: +44 (0) 1386 55 49 68

Flowserve
Allee du Quartz 1
CH-2300 La-Chaux-de Fonds
Switzerland
Telephone: +41 (0) 32 925 9700
Facsimile: +41 (0) 32 926 5422

Flowserve
Cnr. Bismit and Granier Str.
Jet Park Ext 3
Boksburg
1459 Gauteng
South Africa
Telephone: +27 397-3150
Facsimile: +27 397-5300/01/02

Flowserve
C/O Saleh & Abdulaziz Abahsain
P.O. Box 209
Al Khobar 31952
Saudi Arabia
Telephone: 9663 857 3442
Facsimile: 9663 859 5284