



Worcester Controls

WCAIM2019  
(Part 13428)

# 10, 15, 20 ACCESS I 39 Actuators with DeviceNet Interface Installation, Operation and Maintenance Instructions

## DESCRIPTION

Worcester/McCANNNA ACCESS I Series 39 actuators are pneumatic quarter-turn valve actuators with solenoid and limit switches integral to the actuator end cap. The design utilizes a double-rack, single-pinion concept, with each rack integrally cast to a piston. Both pistons are supported and centered by large, stainless steel guide rods. In double-acting units, both pistons are pressurized on both strokes of the actuator. Ambient temperature range of ACCESS unit is 0°F minimum to 160°F maximum.

Standard units feature an extended top shaft for manual override capabilities and a completely modular design which allows simple attachment of a variety of accessories. The units feature a control block (with spool valve) which properly directs supply air to the actuator. The control block provides independently adjustable speed control for both opening and closing strokes of the actuator on double-acting units, and for the closing stroke on spring-return units (standard mounting configuration).

The DeviceNet Interface feature of this equipment permits simple DeviceNet bus connection and communication as either a digital stand alone device on a DeviceNet network or as an additional device to the higher level digital protocol networks via the appropriate "gateway." Solenoid power, actuator opening, actuator closing and electronic position indication are all accomplished via the DeviceNet bus. Integral Light Emitting Diodes (LEDs) display the status of inputs and outputs.

The DeviceNet Board has two Outputs and three Inputs:

Each output is used to control a 3 watt 24 VDC solenoid. When the output is set to 1 or ON, the solenoid will be energized. When the output is set to 0 or OFF, the solenoid will be de-energized.

Each input is used to monitor either a mechanical switch or an AC/DC two-wire NAMUR proximity sensor.

The DeviceNet circuit board has six LEDs. (See Board Layout.)

- Two LEDs for DeviceNet MNS bus activity as required by the ODVA Spec. (green/red) D1 and D2
- Red LED to monitor CW limit switch D3
- Green LED to monitor CCW limit switch D5
- Yellow LED to monitor coil power D4
- Orange LED to monitor solenoid coil continuity D6

The solenoids are powered from the 24 VDC available in the DeviceNet cable. No additional power is required.

The ACCESS/DeviceNet Circuit Board meets the requirements of the ODVA (Open DeviceNet Vendors Association) Specification. It is a Group 2 slave device which operates as a slave device on the DeviceNet network. It supports Explicit, Polled, Change-of-State, and Cyclic I/O Messages of the predefined master/slave connection set. It does not support the Explicit Unconnected Message Manager (UCMM).

The ACCESS DeviceNet Circuit Board has one byte of output (consumed) data and eleven bytes of input (produced) data. In the output byte, bits 0 through 4 are not used, bit 5 is used to control solenoid one, bit 6 is used to control solenoid 2 (not used in this application), and bit 7 is used to reset the maintenance counter. Of the input bytes, byte 1 is used to monitor the switch and solenoid status of the unit with bit 0 used to monitor switch 1 (CCW position), bit 1 is used to monitor switch 2 (CW position), bit 2 is used to monitor switch 3 (not used in this application), bit 3 is used to monitor solenoid 1, and bit 4 is used to monitor solenoid 2 (not used in this application). Bits 5 through 7 are not used. Of the remaining bytes, bytes 2–5 make up the Maintenance Counter, bytes 6–9 make up the Cumulative Counter, byte 10 contains the opening time in seconds, and byte 11 contains the closing time in seconds.

**For connections to the ACCESS/DeviceNet Circuit Board, see Wiring Diagrams in Section B.4.**

The customer field connections to the circuit board take place on terminal block P3 as follows:

**Terminal 1** - Bus negative from 24 VDC supply  
(Next to the P3 label)

**Terminal 2** - CanL signal

**Terminal 3** - Bus Shield

**Terminal 4** - CanH signal

**Terminal 5** - Bus positive from 24 VDC supply

The switch/sensor connections are made to the terminal block labeled as P2. Terminal 1 is located next to the P2 label. The switches/sensors are wired to the terminals such that terminals 1 and 2 are for SW2, and terminals 3 and 4 are for SW1. Positive 24 VDC is provided on terminals 1 and 3 to the switches and the switch returns connect to terminals 2 and 4 respectively.

DeviceNet Board Layout

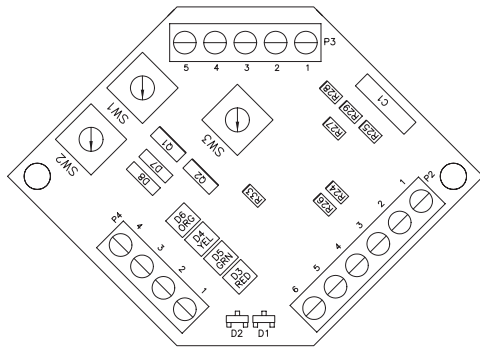

The solenoid connects to terminal block P4 terminals 3 and 4. Positive 24 VDC is supplied to the solenoid coil from terminal 3 and the solenoid coil return is connected to terminal 4. The solenoid is energized by turning on a transistor which connects the return to ground. Should it be necessary to operate a second 24 VDC 3 watt device from terminals 1 and 2, terminal 2 is the positive supply and terminal 1 is the return.

The circuit board has three 10 position rotary switches on board (SW1, SW2, and SW3). SW1 and SW2 are used to set the MACID of the board (i.e., address), with SW2 used for the most significant bit and SW1 used for the least significant bit, e.g., for a MACID of 35, SW2 would be set to 3 and SW1 would be set to 5. Valid MACID values range from 00 to 63. A none-valid MACID setting on the switches allows the MACID to be set through software.

SW3 is used to set the DeviceNet baud rate. Valid baud rate selections are 125k, 250k, and 500k. SW3 position 0 represents 125k, SW3 position 1 represents 250k, and SW3 position 2 represents 500k. If the SW3 position is set to an invalid setting it permits the baud rate to be set through software.

**NOTE: WHENEVER THE BAUD RATE AND/OR MACID IS CHANGED VIA THE SWITCHES, THE BOARD POWER MUST BE CYCLED IN ORDER FOR THE CHANGE TO TAKE EFFECT.**

For additional information see Installation, Operation and Maintenance Supplements 1, 2 and 3 that accompany this product.

**▲ WARNING: SERIES 39 ACTUATORS ARE ELECTROMECHANICAL DEVICES SUBJECT TO NORMAL WEAR AND TEAR. ACTUATOR LIFE IS DEPENDENT UPON APPLICATION AND ENVIRONMENTAL CONDITIONS. IF APPLIED IN HAZARDOUS SERVICES, SUCH AS, BUT NOT LIMITED TO, MEDIA TEMPERATURE EXTREMES, TOXINS, FLAMMABLES, OR OTHER SERVICES WHERE IMPROPER OR INCOMPLETE OPERATION COULD PRODUCE A SAFETY HAZARD, IT IS INCUMBENT UPON THE SYSTEM DESIGNER AND THE USER TO PROVIDE PROPER WARNING DEVICES SUCH AS TEMPERATURE SENSORS, OXYGEN SENSORS AND FLOW SENSORS.**

**CAUTIONS: When actuator is installed in outdoor conditions, water can enter the exhaust hole(s) of the control block and then freeze. Flowserve suggests a cover be used, or mount the actuator such that the block exhaust hole(s) will not fill with water.**

Flowserve recommends that all products which must be stored prior to installation be stored indoors, in an environment suitable for human occupancy. Do not store product in areas where exposure to relative humidity above 85%, acid or alkali fumes, radiation above normal background, ultraviolet light, or temperatures above 120°F or below 40°F may occur. Do not store within 50 feet of any source of ozone.

**IMPORTANT: INCLUDED IN ALL 39 ACTUATOR ACCESSORY AND REPAIR KITS IS A REBUILD/ACCESSORY ADDITION LABEL, WHICH IS TO BE MARKED WITH A PERMANENT MARKER AND THEN APPLIED TO THE ACTUATOR AFTER AN ACCESSORY KIT HAS BEEN INSTALLED OR AN ACTUATOR HAS BEEN REPAIRED**

## INSTALLATION

**NOTE: The Series 39 actuator is normally installed with its major axis parallel to the pipe line. This is mandatory when mounting actuator to 90° V1 diverter/three-way (D44 and T44) valves and CPT valves. The actuator can be oriented above, beside or beneath the valve without affecting its operation.**

Rev. R6 actuators may come with an ISO locating ring used for optional ISO mounting.

- A. Determine mode of operation desired (normally open or normally closed) of the valve.
- B. Determine desired quadrant for bracket attachment and direction of mounting of actuator (inline or cross-line).
- C. Attach mounting bracket to actuator using four (4) cap screws and lockwashers provided in mounting kit. To avoid any damage to the Series 39 actuator body, ONLY the proper length screws supplied with the mounting kit should be used. For ¼"-2" top mount style valves, attach bracket such that bracket nameplate will be to side of valve.

For mounting to 818/828 Series valves, insert ISO locating ring into groove on bottom of actuator before attaching to bracket.

**NOTE: Ring can be permanently held in groove by applying Loctite to ring before inserting in groove.**

- D. Attach bracket/actuator assembly to valve as follows:

**CAUTION: Ball valves can trap pressurized media in the cavity. If it is necessary to remove any valve body bolts, stem nuts or remove valve from the line, and if the valve is or has been in operation, make sure there is NO pressure to or in the valve and operate valve one full cycle. However, the valves mentioned here do not require the removal of any valve body bolts or removal of valve from line in order to mount actuator.**

1. Rotate valve ball and stem to position necessary to achieve desired operation. If any valve information is marked on stop plate or handle, it will be necessary to transfer this information to the bracket nameplate.
2. For ¼"-2" 44, ½"-2" WK70/WK74, ¼"-1½" 59, and ½"-1½" H71 Series top mount style valves and ½"-2" 51/52, ½"-1½" 82/83 Series valves with high-cycle stem packing as standard,

remove handle nut, lockwasher, handle, separate stop plate (if any), retaining nut and stop pin(s). Add the two additional Belleville washers with their larger diameter sides touching each other. Add the self-locking nut to the stem and tighten while holding the stem flats with wrench. Tighten until Belleville washers are flat, the nut will “bottom,” and then back nut off 1/4 of a turn. The two additional Belleville washers and the self-locking nut are included in the mounting kit.

**CAUTION: The self-locking stem nut is difficult to tighten, and must fully flatten Belleville washers before backing off.**

For 2" 59, H71, 82/83, and 2 1/2" 45, 82/83 valves, and valves 3" and larger with square stem, remove handle assembly, retaining nut, stop and stop screws. Replace with valve stem spacer or, if valve has graphite stem packing, with two Belleville washers, and replace retaining nut. NOTE: Belleville washers are installed with their larger diameter sides touching each other. Do not use stem spacer when Belleville washers are used. Using a wrench to prevent stem from turning, tighten retaining nut until stem packing is fully compressed or Bellevilles, if used, are fully flattened, then back off nut 1/4 turn. Excessive tightening causes higher torque and shorter seal life.

**NOTE:** Large valves with V51 high-cycle stem packing option installed, identified by two Belleville washers installed and handle assembly, stop and stop screws removed, and 818/828 Series valves do not require stem area disassembly.

For 2" and larger 818/828 valves, remove handle assembly, locking plates and hardware, and stop screw (if any). Do not remove stop plate or spacer.

For 1/2"-2" 94 valves, remove handle (if any). Do not remove gland plate or gland bolts.

For 3" and larger 94 and 2" and larger E818/828 valves, remove handle assembly, stop, and spacer (if any). Do not remove gland plate or gland bolts.

3. Center coupling on valve stem.
4. Lower mounting bracket/actuator assembly over coupling and onto valve, making sure that male actuator shaft engages slot in coupling.
5. Secure bracket to valve using cap screws and lockwashers, or bolts and nuts provided in mounting kit. Tighten securely. For 1/2"-2" top mount style valves, bracket nameplate will be to the side of the valve.
6. Install set screws (if any) in the coupling and tighten securely
7. Determine if mode of operation is as desired; if not:
  - a. Double-Acting Actuators – Mount the actuator 90° from normal mounting, or the actuator can be inverted, yielding the opposite mode.
  - b. Spring-Return Actuators – The normal method of mounting is to have the actuator inline with the pipe line and the valve and actuator in the “Fail-Closed” position.

For “FAIL-CLOSED” cross-line operation, invert actuator and cross-line mount actuator to pipe line.

For “FAIL-OPEN” inline operation, invert actuator. (NOTE: If inline coupling is used, actuator does not need to be inverted.) Rotate the valve ball and stem 90°, so coupling lines up with actuator shaft. Mount actuator in line with the pipeline. See Electrical Connection Section for proper wiring information.

For “FAIL-OPEN” cross-line operation, rotate the valve ball and stem 90°, so coupling lines up with actuator shaft. Mount actuator cross-line to pipe line. See Electrical Connection Section for proper wiring information.

8. Determine position indication. Buttons on position indicator are set up to show valve closed on inline mounting, i.e., pistons together in actuator. If different indication is required:
  - a. Check which visual indication is required.
  - b. Check that indicator, when located on actuator shaft, will show correct indication.
  - c. To change indication, push out (remove) red and white buttons and reassemble in opposite positions.
  - d. Locate indicator on actuator shaft flats. Press firmly until location nibs snap into recess on pinion.

## AIR SUPPLY AND ELECTRICAL INSTALLATION

- A. 1. Air Supply:
 

The Series 39 Actuator is factory lubricated. For optimum operation, the use of filtered and lubricated air is recommended.
2. Air Supply Pressure:
 

Standard double-acting actuators require 40–120 psig supply air. Spring-return actuators require 80–120 psig supply air. Spring-return actuators can also be set up to operate on supply air pressures ranging from 40–80 psig by using fewer springs. See “Rebuilding Instructions,” Spring-Return Actuator, paragraph 1 on page 10 for proper number and location of springs for reduced supply air pressures.
3. Air Supply Connection:
 

Connect air supply to 1/4" NPT connection on control block.
4. Recommended Tubing Sizes:
 

In order to provide sufficient flow of supply air to the Series 39 actuator, the following tubing sizes are recommended:

Actuator Size	Runs Up To 4 ft. Long	Runs Over 4 ft. Long
10, 15, 20	1/8"	1/4"

5. Air Consumption:
 

The following chart shows the amount of pressurized (80 psig) air consumed per stroke in cubic feet. To determine the total amount of air consumed per complete cycle for double-acting actuators, simply add the volumes for both the opening and closing strokes together; for spring-return units, the total volume of air consumed is the volume shown for the opening stroke.

Stroke	Actuator Size		
	1039	1539	2039
Open	.04	.08	.16
Close	.05	.09	.17

6. Electrical Supply:  
Make electrical connections in accordance with the wiring diagram on the inside of cover or appropriate wiring diagram in Section B.4.

The power supply to the solenoid coil is 3 watts. Required amperage is as follows:

Voltage	Holding Amps
24 VDC	.13

7. Limit Switch/Proximity Sensor Ratings:  
Mechanical Switch - 15.1 amps @ 125/250 VAC; .5 amps @ 125 VDC.  
  
Namur proximity Sensor -  $\geq 1$  mA (target present),  $\geq 3$  mA (Target absent) 15 mA max., 5-25 VDC, sensing range 2 mm, switching frequency 1 KHz. Not sensitive to polarity.

**B. ELECTRICAL CONNECTION:**

1. The “standard” mounting configuration of the 39 actuator to the valve is fail-closed. In this configuration, SW-2, as described in Section B.3 below and in the wiring diagram, will give indication when the actuator is in the closed position and the red LED will be on. SW-1 gives indication of the open position and green LED will be on. Actuator shaft rotation will vary, depending on which fail-closed mounting is used. (Refer to appropriate wiring diagram in Section B.4.).

**NOTE:** The rotation of the actuator shaft, CW (clockwise) or CCW (counterclockwise), is determined when viewing the actuator from the nameplate side of the actuator while being able to read the nameplate from left to right.

2. Fail-open mounting configuration may be obtained by either inverting the actuator, using inline coupling or mounting the actuator cross-line. In these cases SW-1 and SW-2 indication will be reversed from the above, but actuator shaft rotation will vary, depending on which fail-open mounting is used. Wiring shall be done per the appropriate wiring diagram in Section B.4 and adjustments per Section B.3.
3. Switches/sensors (if installed) have been factory adjusted, but should be rechecked after installation. Adjustment is as follows:

- a. With actuator mounted in “standard” “FAIL-CLOSED” mounting configuration (see step 1) and wired per appropriate wiring diagram, set actuator in the full-closed position, with the adjustment screw near its loose limit. The Orange LED indicating solenoid coil continuity will not be lit. The Orange LED will remain off as long as the Yellow LED is off. The orange LED will come on when the coil is energized and there is no short or open in the solenoid coil circuit. If there is a short circuit or open circuit with the coil, the Orange LED will remain off even though the yellow LED indicates that power is applied to the coil circuit. Adjust closed position switch or Namur

Proximity Sensor SW-2 (see wiring diagram) by tightening the adjustment screw until red LED turns on. Then tighten the adjustment screw one additional turn. With air supplied to actuator, energize the solenoid and cycle valve to full-open position. The Yellow and Orange LEDs should be lit indicating power to the coil and coil continuity, respectively. Adjust the open position switch/sensor SW-1 in the same manner as the closed position switch/sensor until the green LED turns on. Then tighten the adjustment screw one additional turn. When the solenoid is de-energized, the actuator will return to its full-closed position. The Yellow, Orange, and Green LEDs will turn off indicating that the solenoid is de-energized and the actuator is no longer in the full-open position. The Red LED will turn on indicating that the actuator is now in the full-closed position.

- b. For actuator mounted in fail-open mounting configuration (see step 2) and wired per appropriate wiring diagram, set actuator in the open position with the adjustment screw near its loose limit. Adjust open position switch or Namur Proximity Sensor SW-2 by tightening the adjustment screw until the green LED turns on. Then tighten the adjustment screw one additional turn. With air supplied to actuator, energize the solenoid to change actuator to the full-closed position. The green LED will shut off and the yellow and orange LEDs should be lit indicating power to the coil, and coil continuity, respectively.

Adjust the closed position switch/sensor SW-1 in the same manner as the open position switch/sensor until the red LED turns on. Then tighten the adjustment screw one additional turn.

When the solenoid is de-energized, the actuator will return to its full-open position. The yellow, orange, and red LEDs will turn off indicating that the solenoid is de-energized and that the actuator is no longer in the full-closed position and then green LED will turn on indicating that the actuator is now in the full-open position.

4. Wiring instructions for solenoid and/or limit switches (Namur Proximity Sensors).

Make electrical connections in accordance with the appropriate wiring diagram on the following page.

5. After electrical connections have been made, place the lubricated O-ring down over the threaded section of the housing onto the machined shoulder. The cover must be threaded onto housing tightly for proper performance. The assembly is now complete.

**NOTE:** For units with a metal cover, a light coat of grease (such as a #1 grease) shall be applied to the cover threads. A minimum of  $\frac{1}{3}$  the circumference of the threads to be lubricated.

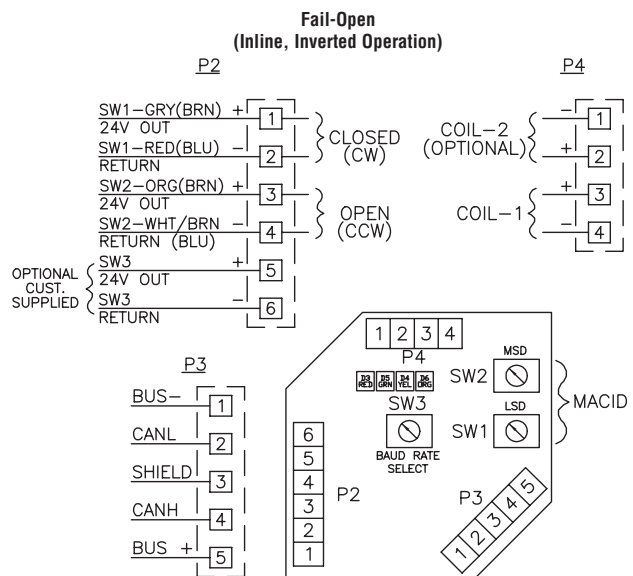
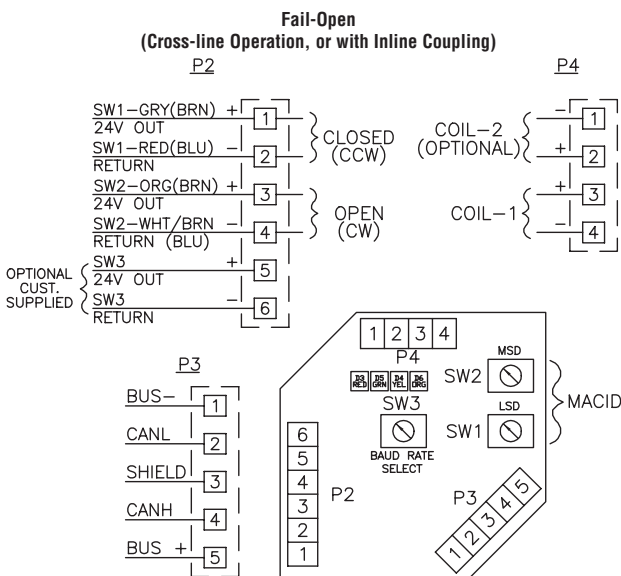
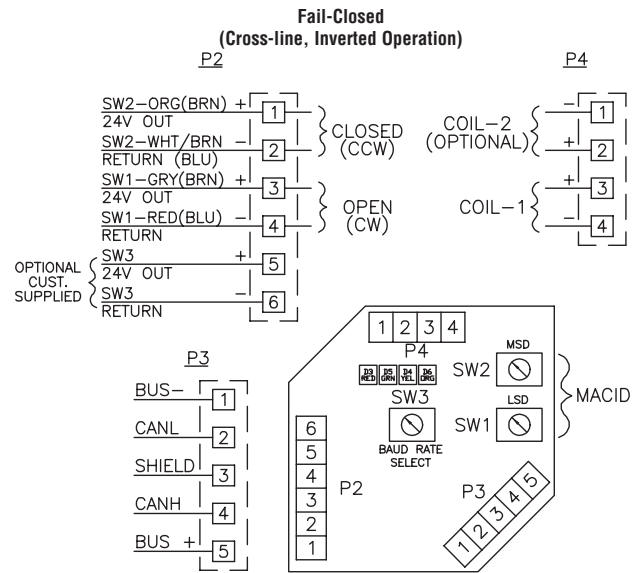
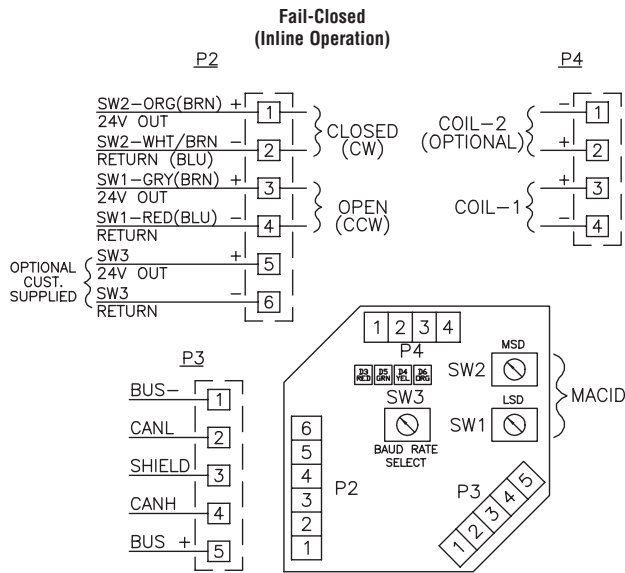

**NOTE:** Wire colors in parentheses are for proximity sensors only.  
For units without switches/sensors, disregard switch/sensor wiring, and also their instructions in Section B.3.

## OPERATION

**A. Double-Acting with Control Block** - Air is supplied to the 1/4" NPT port on the block. When the solenoid is energized, the spring loaded plunger is withdrawn, allowing the supply air to shift the spring-loaded spool within the block, which opens the supply path to the center chamber of the actuator. Air from the end chambers of the actuator is allowed to pass through the block and exhaust to atmosphere.

When the solenoid is de-energized, the spring-loaded plunger blocks the flow of air to the spool seal within the block and the spool spring shifts the spool within the block to a position which opens the supply path to the end chambers of the actuator. Air from the center chamber of the actuator is allowed to pass

through the block and exhaust to atmosphere.

The actuator is electrically fail-safe. That is, it will return to its de-energized position upon electrical failure.

The unit has two independently-adjustable speed control screws which can be used to adjust the speed of operation for the opening and/or closing stroke (see figure 1 on page 7). If the speed control screws are too tight, the unit will fail to operate.

**NOTE:** Speed control screws are shipped from the factory in the full-open position.

**B. Spring-Return with Control Block** - Air is supplied to the 1/4" NPT port on the block. When the solenoid is energized, the spring-loaded plunger is withdrawn, allowing the supply air to shift the

spring-loaded spool within the block, which opens the supply path to the center chamber of the actuator. Air from the end chambers of the actuator is allowed to pass through the block and exhaust to atmosphere.

When the solenoid is de-energized, the spring-loaded plunger blocks the flow of air to the spool within the block and the spring-loaded spool returns to a position which allows air from the center chamber of the actuator to pass through the block and exhaust to atmosphere as the actuator is cycled by the springs in the end chambers of the actuator. The end chambers are exhausted to atmosphere at all times.

The actuator is fail-safe. That is, it will return to its de-energized position upon electrical or pneumatic failure.

The unit has one speed control screw, which can be used to adjust the speed of operation for the closing stroke (on a fail-closed unit) or opening stroke on a fail-open unit, and one port plugged with a red plastic plug (see figure 1 on next page). If the speed control screw is too tight, the unit will fail to operate.

**Note:** Speed control screws are shipped from factory in the full-open position.

---

**CAUTIONS:** If converting a double-acting actuator to a spring-return actuator or vice-versa, be sure the correct control block gasket is used. Also, be sure that all gaskets are properly installed (see figure 2 on next page and actuator exploded view). Do not apply any grease to gasket, it must be installed dry. Be sure red plastic plug is installed in plugged port (see figure 1 on next page) for spring return actuators.

---

**C. Standard Stroke Times**

For stroke times of the ACCESS I Series 39 actuator with solenoid and control block, consult factory. Times will be measured in seconds and will represent average times under 50% load conditions with an air supply pressure of 80 psig. Times will be per stroke for double-acting actuators. For spring-return actuators, the opening stroke times may be slightly longer; stroke times for the closing (spring) stroke will be dependent upon the number of springs used. Cycle times for customer air supply systems will be dependent upon customer equipment.

**D. Manual Operation**

In the event of air failure, the ACCESS I Series 39 actuator can be cycled manually. This is accomplished by applying a wrench to the exposed top shaft of the actuator and turning it in the desired direction.

---

**WARNING:** Care must be taken to ensure that the actuator is not operated automatically while manual operation is being performed.

---

If a routine cycle check is to be performed on an actuator with a control block, the actuator can be cycled manually by shifting the spool valve within the control block. This can be done by pushing the override button in the control block (see figure 1 on page 7 for location of button). Care must be taken to hold the spool valve

in the desired position until the actuator has cycled. Provided the air supply is still on, the actuator will cycle to its original position as soon as the manually applied pressure on the override button is released.

## MAINTENANCE

---

**CAUTION:** The actuator must be isolated both pneumatically and electrically before any maintenance activity is begun.

---

Periodic checks should be performed to make certain that all fasteners remain tight. Care should be taken when tightening the end cap retaining bolts since these fasteners are METRIC. All other fasteners are UNIFIED IMPERIAL.

All actuators are supplied with sufficient lubrication for their normal working life. If required, recommended lubrication for all standard actuators is a #1 grease.

Depending upon the conditions under which the actuator must work, such as extended duty, non-compatible operating media or abnormal operating conditions, periodic replacement of internal seals is recommended. Repair kits containing all necessary seals can be obtained through any authorized Worcester/McCANNA distributor.

On spring-return actuators, the springs may need replacement after extended duty since springs may fatigue and break. SPRINGS SHOULD ALWAYS BE REPLACED IN COMPLETE SETS. Spring kits are available through any authorized Worcester/McCANNA distributor

## SPARE PARTS

The following are recommended spare parts which should be kept on hand for Series 39 pneumatic actuators:

- Repair Kit(s) - Kits contain all necessary seals, bearings and instructions.
- Spring Kit(s) - For Spring-Return Actuators.

## TROUBLESHOOTING

BEFORE DISASSEMBLING ACTUATOR FOR ANY REASON, CONSULT REBUILDING INSTRUCTIONS CONTAINED IN FOLLOWING SECTION.

**A.** If actuator does not function, check to ascertain:

1. That valve is free to rotate. This can be done as described above in Manual Operation.
2. That actuator is the correct size.
3. That speed control screws or exhaust ports are not blocked.
4. That correct voltage is supplied to solenoid.
5. That sufficient air supply is available at inlet to control block. Inlet pressure to control block should be at least 40 psig for double-acting, 80 psig for spring-return (unless a reduced

Figure 1

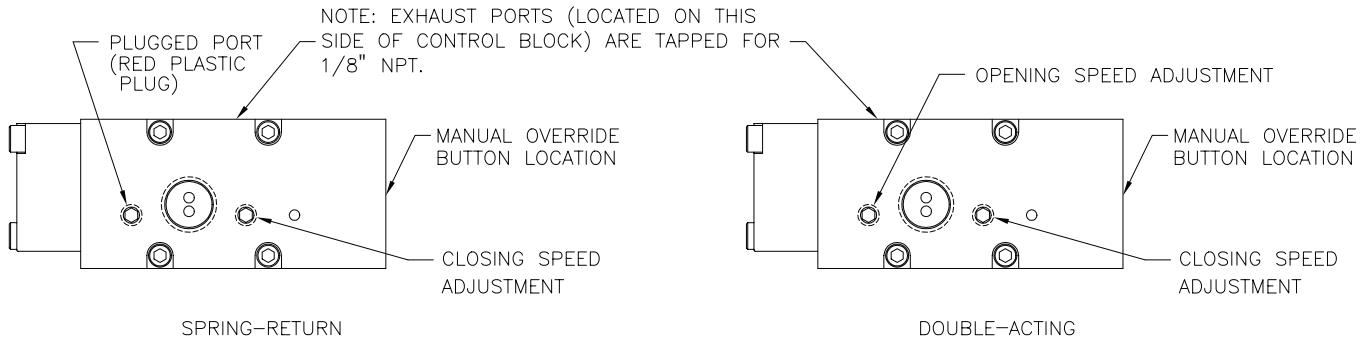
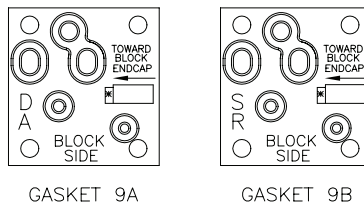

Figure 2



spring complement is installed). When checking supply pressure, place gage inline at control block inlet and monitor gage for unexpected pressure drops.

**B.** If proper voltage and air pressure have been verified and valve is free, proceed as follows:

1. Turn on signal voltage. Check solenoid for clicking sound.
2. If no sound is detected, remove air pressure and turn off signal voltage.
  - a. Carefully unscrew solenoid and solenoid stem from end cap.
  - b. Reapply signal voltage and observe solenoid plunger. If it does not retract, replace solenoid.
3. Manually override control block. If correct operation is not obtained, replace the control block.
4. If control block and solenoid are operating correctly, proceed to next section.

**C.** If the actuator functions but exhibits leakage or power loss accompanied by leakage, proceed as follows:

1. Check voltage. Voltage must be within 10% of the specified voltage (low voltage will cause leakage out of the back of the solenoid and burn out of the coil).
2. Check air supply. Be certain that no sharp air pressure drops occur as unit is cycled. Loss of air pressure can cause incomplete shifting of the spool valves, which results in bypass leakage and substantial actuator torque losses.

3. If air supply and voltage are adequate, proceed as follows:

- a. If leak is at solenoid exhaust port, replace the solenoid.
- b. If leak occurs at exhaust ports in the block itself, the trouble will be in either the spool valve in the block, or at one of the piston seals of the actuator. A leaking piston seal will usually leak on either cycle.

If the block is replaced and leakage continues from the exhaust port, remove the actuator from the valve, disassemble (per Rebuilding Instructions on page 8) and check the following:

- 1) Make sure that all internal porting is free and clear of any obstructions. End caps, guide rods and the piston with hole are air transporting components.

**NOTE:** The most common problem encountered on 39 actuators is the improper replacement of the piston with hole relative to seals in end caps. (See Step 5 on page 9.)

- 2) Make certain that the actuator has lubrication, and that there is no solidified grease between the pinion and the piston racks.
  - a) If actuator has no lubrication, apply generous amount of a #1 grease.
  - b) If solidified grease between the pinion and the piston racks is present, clean, dry, regrease and reassemble.

- 3) Verify that actuator pinion shaft and/or pistons are not bound. If bound, reassemble per Rebuilding Instructions.
- 4) If unit exhibits excessive amounts of backlash, check teeth on piston racks for wear. If worn, replace piston assemblies.
- 5) In spring return actuators, check for misplaced or broken springs. If springs are broken, check body bore for scoring.
  - a) If springs are broken, replace springs. **SPRINGS SHOULD ALWAYS BE REPLACED IN COMPLETE SETS.**
  - b) If body bore is scored, replace it. Also, replace piston O-rings (contained in repair kit).
- 6) If actuator is free, valve is free and control block, if used, is shifting air properly, reassemble the actuator and retest. If unit still fails to operate, consult Flowserve.

---

**CAUTION:** If the actuator is a spring-return model, first remove two end cap screws diagonally opposite each other, then lubricate the threads and under the head. Replace the screws and repeat procedure for the other two screws. Do this for each end cap as this will aid reassembly. Now uniformly loosen all four end cap screws on each end cap two to three turns at a time, in sequence, to relieve pre-load of the springs. On larger actuators with springs use caution when removing end caps. End cap screws are long enough to allow springs to relieve before disengaging.

---

- After the screws are removed, gently pry off each end cap, being careful not to damage the end cap O-rings.
6. The two piston guide rod (4) assemblies can now be removed from each end of the body and disassembled by removing the piston set screws (12). Do not interchange piston guide rods (4) and their respective piston (3). For some actuators, each guide rod and piston may be press fitted together (do not use set screws) and cannot be disassembled. (To assist reassembly, mark the body with a line on the side from which the guide rod using the through-hole is removed). Remove all O-rings (15B) and (15C) and bearings (6B) from pistons (3).
  7. The shaft (2) can only be removed after piston assemblies are taken out. Remove the position indicator (17) (if any), the shaft clip (15F) (not a reusable part!) (see Note below) and the stainless steel washer from the top of shaft. Then remove the shaft through the larger opening in the bottom of the body. The top bearing (15G) and the O-ring (15D) can now be removed. Remove the two stainless steel washers and thrust bearing (10) from the top of the shaft and the O-ring (15E) and bearing (15H) from the bottom end.

## REBUILDING INSTRUCTIONS

**NOTE:** For identification of all numbered parts discussed below, consult exploded view of actuator.

After actuator has been repaired, mark rebuild label accordingly and apply to actuator.

## ACTUATOR DISASSEMBLY

1. Disconnect the air supply and electrical service to the actuator.
2. Remove the actuator and its mounting bracket from the valve. (See Caution note below.)

---

**CAUTION:** Ball valves can trap pressurized media in the cavity. Isolate the piping system in which the actuator valve assembly is mounted and relieve any pressure on the valve. For all valves listed in Installation Section D, the actuator bracket can be removed without loosening or removing any valve body bolts.

---

3. Remove the actuator bracket from the actuator to begin repair. (Note mounting of removed bracket for easy reassembly.)
4. It is not necessary to remove the control block (7A) to rebuild actuator. However, if it becomes necessary to remove the block, begin by removing the block bolts (7D). Use care to retain the block gasket (9A or 9B).
5. Each end cap (5A and 5B) is aligned onto the body (1) over a "foolproof pin." This ensures that the end caps can only be assembled to their respective end of the actuator. Remove all four metric screws (5C) from and remove both end caps. Remove the two bearings (6A) and O-rings (15A and 15B) from each end cap.

**NOTE:** Some actuators may be using a spiral ring type shaft clip as shown at right.



To remove this clip, engage the lower end of the ring with a flat blade screwdriver. Using another flat blade screwdriver push the top end of the clip in the opposite direction. As the clip I.D. expands, lift the clip from the shaft. The installation of a new clip would be the above steps in reverse and ensuring that the edges of the clip are properly seated in the shaft groove.

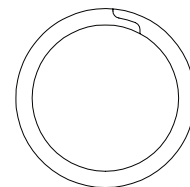

## ACTUATOR REASSEMBLY

1. Be sure the actuator surfaces are clean and free of grit and scratches. If the inside walls of the body are scored, or the guide rod surfaces are scratched, the actuator will leak after rebuilding. New parts should be obtained from the factory. Light tracking, barely detectable to touch, is acceptable.
2. All rebuilding kit O-rings and bearings may now be installed. Lubricate the standard actuator thoroughly with a #1 grease. Apply a light film of grease to all O-rings. (Note that kits also contain some parts for earlier revisions of actuators which will not be needed.)



3. Replace the two split-ring style bearings (6A) and one guide rod O-ring (15B) in each end cap.

Replace the split-ring style bearing (6B) and guide rod O-ring (15B) into I.D. grooves in each piston. Install O-rings (15C) onto pistons.

4. Replace O-ring (15E) and bearing (15H) on the bottom of shaft. On the top of the shaft add the two stainless steel washers with the thrust bearing (10) between them. Locate the top bearing (15G) and O-ring (15D) into the body. NOTE: Top bearing (15G) is flat, the same as and interchangeable with thrust bearing (10). Replace the shaft through the larger opening in the bottom of the body.
5. Very carefully align the piston guide rod assemblies inside the body. Keep the pistons square to the body.

**IMPORTANT:** One piston guide rod assembly has a through-hole drilled in it. It can be easily located by looking down the ends of both guide rods. This piston assembly must be reassembled, with its respective guide rod, opposite the nameplate on the body, as it was removed.

6. Align the shaft so that the teeth on the shaft will “pick-up” the piston assembly’s rack teeth when turning the top extension of the shaft clockwise (CW). (See Figure 3 below.)

**IMPORTANT:** Proper 90° rotation can only be ensured if the shaft teeth begin to mesh with the piston assembly’s teeth at the “proper tooth” between these meshing gear pairs. (See Figure 3 below.)

7. To ensure proper meshing of teeth, move the shaft 15 to 20 degrees counterclockwise (CCW) from its normal position when the piston assemblies are located at the body ends. NOTE: The “normal position” of the shaft is when the top flats are parallel to the main axis of the actuator body.

8. With the piston assemblies in the body, gently push each piston into the body. Turn the top shaft extension clockwise (CW). Do not allow the pistons to “cock”.

At the proper point of engagement between the shaft and piston assemblies, both piston assemblies will move toward the center of the body when turning the top shaft extension of the actuator clockwise (CW).

9. Once the shaft and pistons are properly engaged, ensure that smooth movement and full-closed operation can occur without moving the pistons out of the actuator body. This is important!
10. Install O-ring (15A) into and replace the actuator end caps, (5A and 5B), noting that the “foolproof” pin between the body and end cap mates properly. For spring return actuators, see spring installation section on page 10 before installing end caps.

**NOTE:** When installing the end cap O-rings, use a small amount of a general purpose lubricant, such as petroleum jelly, to hold them in place for ease of assembly and to avoid having them fall and get pinched.

11. Replace the stainless steel washer over the top shaft extension.

**12. VERY IMPORTANT:**

Install the NEW shaft clip (15F) into its mating groove on the top shaft extension. The removed shaft clip is not to be reused.

Place the numbered side up on the shaft clip and be certain the clip is fully seated in its groove. See Note in paragraph 7 of Actuator Disassembly on page 8 for installation of spiral-ring type shaft clip (which newer repair kits will contain).

13. If control block (7A) was removed:

Properly insert appropriate gasket (9A or 9B) between control block or air connection block and end cap (see Figure 2 on page 7 and actuator exploded view), and attach block securely to end cap. Do not apply any grease to gasket, it must be installed dry.

14. Replace position indicator (17) (if any). See Section D.8. in Installation Section for proper installation and to determine position indication.

15. Mark Rebuild/Accessory Addition Label, if included in repair kit, and apply to actuator.

Figure 3

DOUBLE ACTING ACTUATOR

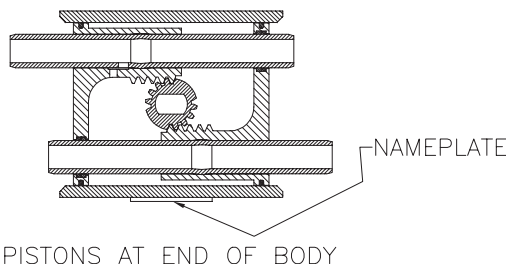

PISTONS AT END OF BODY

**IMPORTANT:** Note the relative location of the shaft teeth and the piston assembly’s rack teeth. The above figure is viewed when looking at the top of the actuator.

# SPRING-RETURN ACTUATOR

## 1. IMPORTANT:

When less than the standard number of springs are used in each end cap, these springs should be positioned according to the air supply figures below.

### Size 10-20

70 psi - 8 springs - 4 per end cap.	Remove center spring.
60 psi - 8 springs - 4 per end cap.	Remove center spring.
50 psi - 6 springs - 3 per end cap.	Use three on a diagonal.
40 psi - 4 springs - 2 per end cap.	Use two in opposite corners.

The values listed below are for standard and less than the standard air pressure as required per the ordering code.

**NOTE:** Maximum Operating Pressure Does Not Change.

Ordering Code	4	5	6	7	( )
Supply Pressure (psi)	40	50	60	70	80
Actuator Size	End of Spring Torque (in-lb)				
10	35	55	75	75	95
15	65	105	145	145	185
20	125	195	265	265	335

- If a spring-return actuator is being repaired due to a failed spring, REPLACE all the springs in this actuator, as well as any other parts which may have been damaged.
- When replacing the springs in a spring-return actuator, place the springs in the end cap pocket after thoroughly lubricating each spring. Be generous with lubricant!
- With the springs pointing up and the end cap on a solid surface, place the actuator body over the springs and the proper end cap. (Each end cap can only be mounted to just one end of the actuator body, as there is a "fool proof" pin in the end cap which aligns with a hole in the body.)
- Force the body down and begin by engaging two end cap screws (5C) by hand through the end cap. Take each end cap screw up in SMALL and EQUAL turns. Once the end cap is temporarily secured to the body, turn the actuator over to its normal position and uniformly take up the four end cap screws. Uniformly load all the springs to prevent any spring from buckling.
- In a similar manner, as in the previous steps, replace the springs in the other end of the actuator body.

## PARTS LISTING

ITEM	QTY.	DESCRIPTION	ITEM	QTY.	DESCRIPTION
1	1	Actuator Body	14	Varies	Springs - See Table on Page 12
2	1	Shaft (10-2039)	15A	2	End Cap O-rings
3	2	Pistons	15B	4	Guide Rod O-rings
4	2	Guide Rods	15C	2	Piston O-rings
5A	1	ACCESS End Cap	15D	1	Top Shaft O-ring
5B	1	End Cap	15	1	Bottom Shaft O-ring
5C	8	End Cap Screws (Metric)	15F	1	Shaft Clip
5D	1	Cover "Z"	15G	1	Top Pinion Bearing
5E	1	Caution Nameplate "Z"	15H	1	Bottom Pinion Bearing
5F	1	Cover "W"	16	1	Wiring Diagram - Not Shown
5G	1	O-ring - Cover	17	1	Position Indicator
6A	4	End Cap Bearing (Split-Ring Style)	18	2	Drive Screw
6B	2	Piston Bearing (Split-Ring Style)	19	2	Probes
7A	1	Control Block Assembly	20	2	O-rings - Probe
7B	-	Not Used	21	4	Washers - Probe
7C	-	Not Used	22	2	Retaining Clips - Probe
7D	4	Control Block Bolts	23	2	Spring - Probe
8A	1	Solenoid Assembly	24	1	Printed Circuit Board (Circuit Board Shown)
8B	2	Solenoid Exhaust Port Fittings	25	2	Printed Circuit Board Mounting Screws
8C	1	Solenoid Exhaust Tubing	26A	1	Limit Switch (Proximity Sensor) Assembly - Left
9A	1	Gasket - Control Block (Double-Acting) (Fig. 2)	26B	1	Limit Switch (Proximity Sensor) Assembly - Right
9B	1	Gasket - Control Block (Spring-Return) (Fig. 2)	27	4	Mounting Screws - Limit Switch (Proximity Sensor)
10	1	Thrust Bearing	28	2	Switch (Sensor) Adjustment Screw
11	1	Nameplate	29	2	Switch (Sensor) Adjustment Spring
12	2	Piston Set Screws (if any)			
13	1	Conduit Plug - Not Shown			

To order proper parts, please specify the actuator size, model, and revision number. Use the standard nomenclature listed above.

The rebuilding kits include Items 15A thru 15H, 6A and 6B, 10, and stainless steel washers. Color of some replacement parts, such as bearings, may vary from the parts removed.

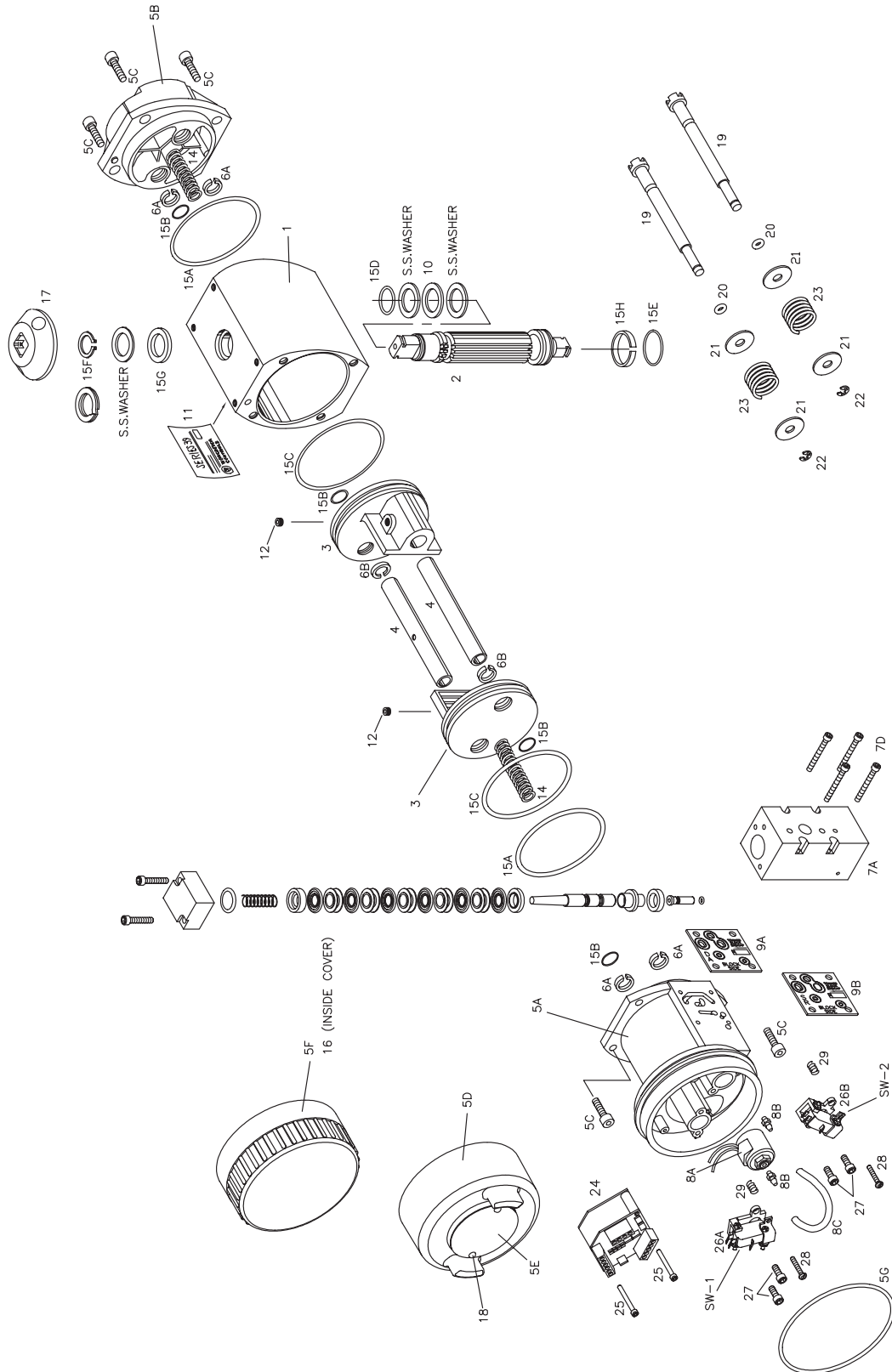

ACCESS I and 39 Actuator Exploded View

Flowserve Corporation has established industry leadership in the design and manufacture of its products. When properly selected, this Flowserve product is designed to perform its intended function safely during its useful life. However, the purchaser or user of Flowserve products should be aware that Flowserve products might be used in numerous applications under a wide variety of industrial service conditions. Although Flowserve can (and often does) provide general guidelines, it cannot provide specific data and warnings for all possible applications. The purchaser/user must therefore assume the ultimate responsibility for the proper sizing and selection, installation, operation, and maintenance of Flowserve products. The purchaser/user should read and understand the Installation Operation Maintenance (IOM) instructions included with the product, and train its employees and contractors in the safe use of Flowserve products in connection with the specific application.

While the information and specifications contained in this literature are believed to be accurate, they are supplied for informative purposes only and should not be considered certified or as a guarantee of satisfactory results by reliance thereon. Nothing contained herein is to be construed as a warranty or guarantee, express or implied, regarding any matter with respect to this product. Because Flowserve is continually improving and upgrading its product design, the specifications, dimensions and information contained herein are subject to change without notice. Should any question arise concerning these provisions, the purchaser/user should contact Flowserve Corporation at any one of its worldwide operations or offices.

For more information about Flowserve Corporation, contact [www.flowserve.com](http://www.flowserve.com) or call USA 800 225 6989.

**FLOWSERVE CORPORATION**  
**FLOW CONTROL DIVISION**  
1978 Foreman Drive  
Cookeville, Tennessee 38501 USA  
Phone: 931 432 4021  
Facsimile: 931 432 3105  
[www.flowserve.com](http://www.flowserve.com)