



USER INSTRUCTIONS

Worcester Controls

Pulsair III Digital
Electronic Positioner

FCD WCAIM2056-00 – 08/04 (Replaces IOM-19990)

Installation
Operation
Maintenance



Contents

1 Introduction	4
Safety Instruction	4
2 Storage	5
General	5
Storage Indoors	5
Storage Outdoors or for a Longer Period	6
Storage in a Warm Place	6
3 Design	7
4 Variants	8
Pulsair III 270° (W)	8
Pulsair III Explosion-Proof (Z)	8
Pulsair III Intrinsically Safe	8
Pulsair III Remote Mounted	8
5 Function	9
Double-Action Function	9
Single-Action Function	9
6 Installation	10
Tubing	10
Air Supply Requirements	10
Mounting	11
Connections	12
Air	12
Electrical Connection	12
Dimensions	12
Single-Action Positioner (Direct Function)	13
Double-Action Positioner (Direct Function)	14
Electrical Connections	14
7 Control	16
Menu and Pushbuttons	16

Other Functions	16
Menu Indicator	17
Menus	17
Changing Parameter Values	18
Basic Menu: Calibrate	19
First Start	19
Calibration Error Messages	19
Basic Menu: Read	22
Basic Menu: Man/Aut	23
Basic Menu: Shift Menu	23
Full Menu: Protection	24
Full Menu: Status	25
Full Menu: Setup	26
Full Menu: Tuning	32
Full Menu: Alarms	34
Full Menu: Fact Set	38
8 Maintenance/Service	40
Disassembling Pulsair III W	40
Silencer	44
Spindle Adapter	44
Potentiometer	45
Transmitter Boards	46
Disassembling the Worcester Pulsair III Z	51
Filter Change, Pulsair III W and Z	52
Converting for Remote Control	52
9 Troubleshooting	54
10 Technical Data	55
11 Spare Parts	58

1 Introduction

The PULSAIR III is a digital positioner designed primarily for controlling modulation valves.

The positioner can be used with single- or double-action actuators with either rotary or linear movement.

The PULSAIR III can be equipped with modules for feedback, limit switches, and a pressure gauge block.

The modules can be factory-assembled before delivery or fitted later.

The modules for feedback and limit switches can contain 4-20 mA feedback and one of the following functions:

- Two mechanical switches
- Two reed switches
- Two inductive sensors

Safety notices are presented in this manual in three forms:

▲ Warning: Refers to personal safety. Alerts the user to potential danger. Failure to follow warning notices could result in personal injury or death.

☠ Caution: Directs the user's attention to general precautions that, if not followed, could result in personal injury and/or equipment damage.

NOTE: Highlights information critical to the user's understanding of the actuator's installation and operation.

Safety Instruction

Read the safety instructions in this manual carefully before using the product. The installation, operation, and maintenance of the product must be done by staff with the necessary training and experience. If any questions arise during installation, contact the supplier/sales office before continuing work.

▲ Warning:

- The valve package moves when in operation and can cause personal injury or damage if handled incorrectly.
- If the input signal fails or is turned off, the valve moves quickly to its end position.
- If the compressed air supply fails or is turned off, fast movements can occur.
- The valve is not controlled by the input signals when in the "Out of service" mode. It will open/close in the event of a leak.
- If a high value is set for Cut off, fast movements can occur.
- If the valve is controlled in the Manual mode, the valve can move quickly.
- Incorrect settings can cause self-oscillation, which can lead to damage.

Important:

- Always turn off the compressed air supply before removing or disconnecting the air supply or the integral filter. Remove or disconnect with care because C- is still under pressure even after the air supply is turned off.
- Always work in an ESD protected area when servicing the PCBs. Make sure the input signal is switched off.
- The air supply must be free from moisture, water, oil and particles.

2 Storage

General

The PULSAIR III positioner is a precision instrument. Therefore, it is essential that it is handled and stored in the correct way. Always follow the instructions below!

NOTE: As soon as the positioner is connected and started, an internal air leakage will provide protection against corrosion and prevent the ingress of moisture. For this reason, the air supply pressure should always be kept on.

Storage Indoors

Store the positioner in its original packaging. The storage environment must be clean, dry, and cool 60-80°F (15-26°C).

Storage Outdoors or for a Longer Period

If the positioner must be stored outdoors, it is important that all cover screws are tightened and that all connections are properly sealed. The unit should be packed with a desiccant (silica gel) in a plastic bag or similar, covered with plastic, and not exposed to sunlight, rain, or snow.

This is also applicable for long-term storage (more than 1 month) and for long transport by sea.

Storage in a Warm Place

When the positioner is stored in a warm place with a high relative humidity and is subjected to daily temperature variations, the air inside the unit will expand and contract.

This means that air from outside the unit may be drawn into the positioner. Depending on the temperature variations, relative humidity, and other factors, condensation and corrosion can occur inside the unit, which in turn can give rise to functional disorders or a failure.

3 Design

The PULSAIR III positioner contains:

- electronic board with microprocessor, HART modem, display etc.
- pneumatic valve block
- positional feedback with potentiometer
- sealed compartment for electrical connections.

The pushbuttons and display are accessible underneath the aluminum cover, which is sealed with an O-ring.

The figure shows the PULSAIR III with the cover removed.

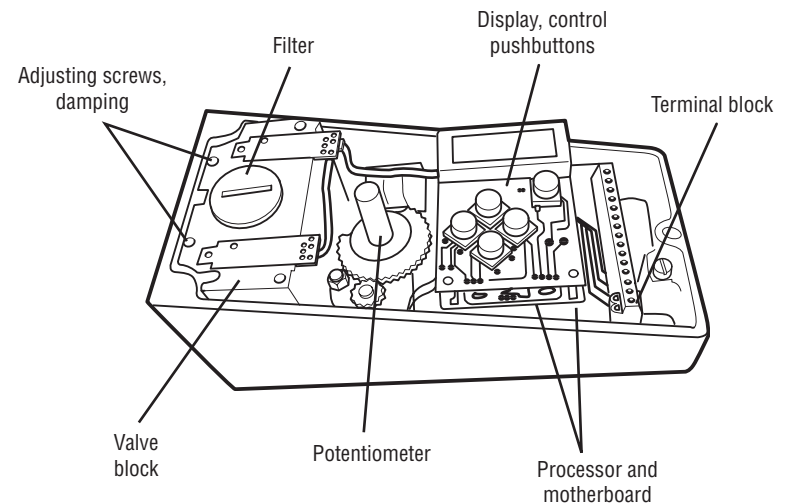

4 Variants

Pulsair III 270° (W)

A Pulsair III for up to 270° extended travel range is available. It features all benefits and options similar to the standard Pulsair III. Communication with HART is possible.

*Standard Housing
Weatherproof (W) and
Intrinsically Safe*

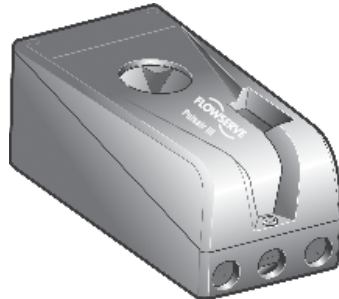

Pulsair III Intrinsically Safe

The Pulsair III is available in an intrinsically safe version for installation in hazardous areas. It features the same easy-to-use user interface for local configuration as the Pulsair III. Communication with HART is possible. It features all benefits and options similar to the Standard Pulsair III positioner: gauge block, local graphic LCD display, feedback option, etc.

"Z" Housing



Pulsair III Explosion-Proof (Z)

The Pulsair III digital positioner is available in an explosion-proof enclosure. It features the same easy-to-use user interface for local configuration as the Pulsair III. Communication with HART is possible.

Further features are gauge ports and local graphic LCD display.

Remote Mount



Pulsair III Remote Mounted

The Pulsair III with remote mount is now available. This version is suitable for installations in severe applications, e.g. vibration, high or low temperature, corrosive environment, difficult to access installations, etc. A flat or dome-style indicator can be fitted on the feedback box installed on the actuator. The maximum recommended distance between the Pulsair III and remote unit is 16 ft. (5m).

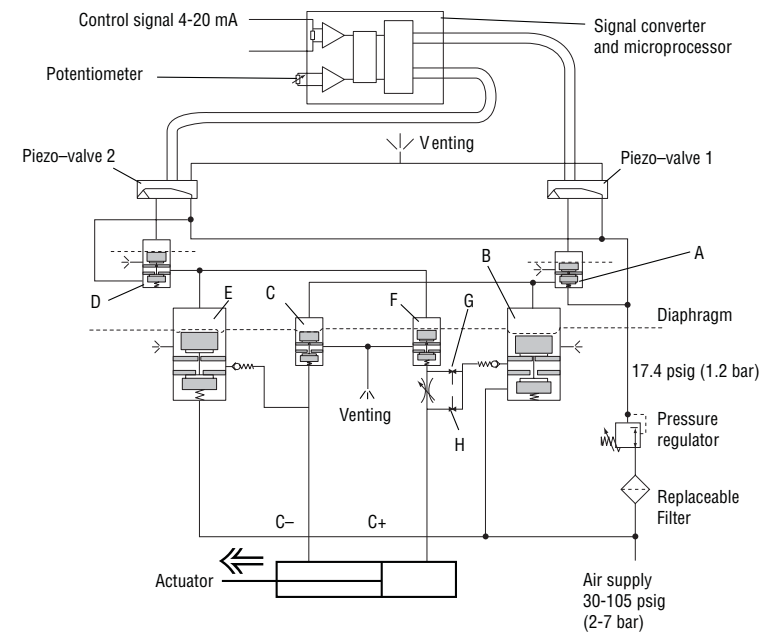

5 Function

Double-Action Function

The control signal and the feedback potentiometer position are converted to digital signals that are processed with a PID algorithm in the microprocessor. This provides control signals to the two piezo-valves.

The two piezo-valves are closed in the schematic diagram above and have no effect on the valves A and D. Air from the pressure regulator is lead through the open valve A to the valve B, which opens. The supply pressure can now pass through valve B to the actuator via H. The actuator then moves in the direction of the arrow. At the same time, air from valve A keeps valve C open and allows venting of the actuator.

When both the piezo-valves open, valve A closes but valve D opens and controls valves E and F to that the actuator moves in a direction opposite to the arrow. When only piezo-valve 1 is open, the actuator is stationary.

Single-Action Function

Valve B is used for the supply air and valve F for venting.

6 Installation

Tubing

Use tubes with an inner diameter of 1/4" (6 mm) minimum.

Air Supply Requirements

For the maximum air supply pressure, see section 10, Technical Data.

The air supply must be free from moisture, water, oil, and particles.

The air must come from a refrigeration-dried supply or be treated in such a way that its dew point is at least 18°F (10°C) below the lowest expected ambient temperature. If air is now used, the supply medium must be a noncorrosive and non-flammable gas.

To ensure a stable and problem-free air supply, we recommend the installation of a filter/pressure regulator <30 microns as close to the positioner as possible.

Before the air supply is connected to the positioner, open the hose freely for 2 to 3 minutes to allow any contamination to be blown out.

Direct the air jet into a large paper bag to trap any water, oil, or other foreign materials. If contamination is detected, the air supply should be thoroughly cleaned before connecting to the positioner.

▲ Warning: Do not direct the open air jet towards people or objects because it may cause personal injury or damage.

Poor air supplies are the main source of problems in pneumatic and electro-pneumatic systems.

Mounting

NOTE: If the positioner is installed in a hazardous environment, it must be of a type approved for this purpose.

The PULSAIR III W positioner has an ISO F05 footprint, A. The holes are used to attach it to the mounting bracket B, which is suitable for most types of linear actuator.

The spindle adapter C can be changed to suit the actuator in question.

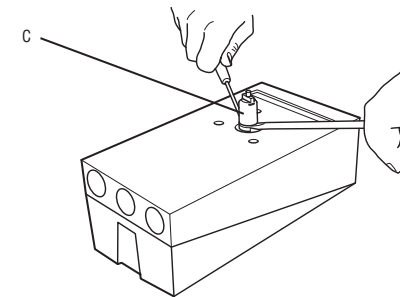

Remove the existing adapter using two screwdrivers. Check that the spring ring on the new spindle is undamaged and fits the new adapter before installing.

It is important that the positioner's spindle and the arms that transfer the actuator movements are correctly mounted. Any tension between these parts can cause incorrect operation and abnormal wear.

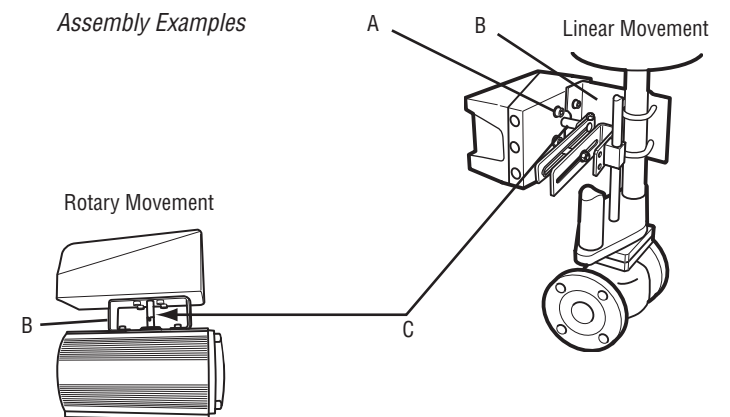

The PULSAIR III Z positioner has an ISO F05 footprint, A. The holes are used to attach it to the mounting bracket B, which is suitable for most types of linear actuators.

The spindle adapter C can be changed to suit the actuator in question, as previously explained in this section.

For data for air and electrical connections, see Technical Data section.

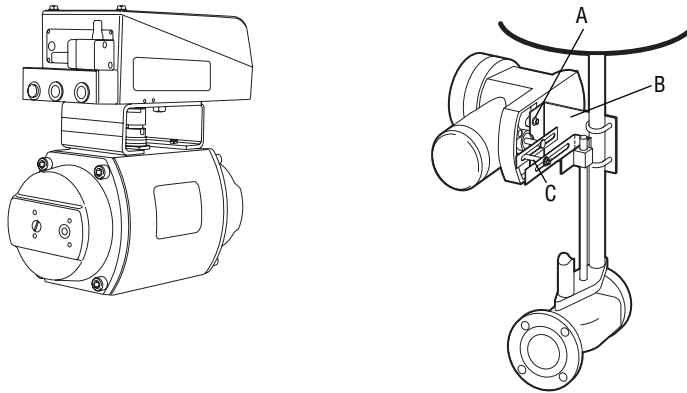

Connections

Air

- Port S Supply air
- Port C+ Connection to actuator
- Port C- Connection to actuator (only for double-action)

Must be plugged when converting to single-action function.

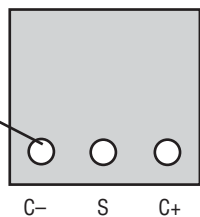

Electrical Connection

See Electrical Connections section.

Dimensions

Air connections: 1/4" NPT or G 1/4"

Electrical connection: 1/2" NPT or M20 x 1.5

Loctite 577 or equivalent is recommended as a sealant.

For data for air and electrical connections, see Technical Data section.

Single-Action Positioner (Direct Function)

Actuator with Fail/Close Spring

When the control signal increases, the pressure C+ to the actuator is increased. The valve stem moves upward and rotates the positioner spindle counterclockwise. When the control signal drops to zero, C+ is vented and the valve closes.

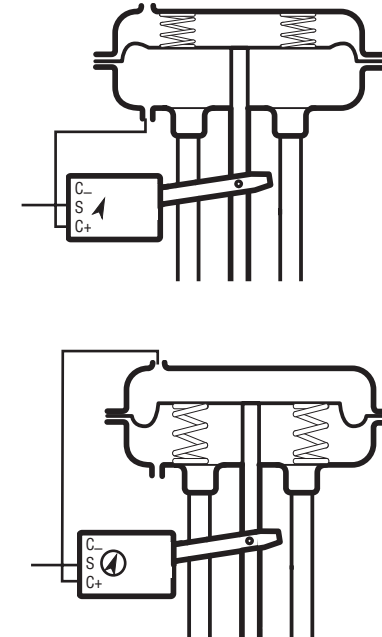

Actuator with Fail/Open Spring

When the control signal increases, the pressure C+ to the actuator is decreased. The springs press the valve stem upward and the positioner spindle rotates counterclockwise. When the control signal drops to zero, C+ is vented and the valve opens.

Double-Action Positioner (Direct Function)

Double-Action Actuator

When the control signal increases, the pressure C+ to the actuator is increased. The valve stem is pressed upward and rotates the positioner spindle counterclockwise. When the control signal is reduced, the pressure C- to the actuator increases and the valve stem is pressed downward. If the control signal disappears, the pressure goes to C-, C+ vents, and the valve closes.

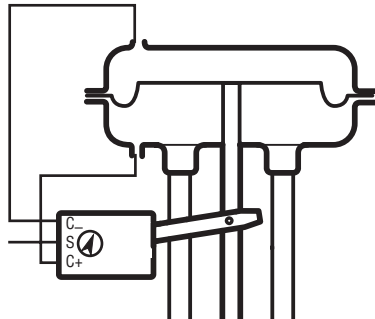

Electrical Connections

The diagrams on the next page show the terminal blocks in the Pulsair III W and Z.

Remote Unit

The remote unit shall be connected between terminals 3, 4 and 5 in the Pulsair III and 3, 4 and 5 in the remote unit. Use a shielded cable and ground it in the Pulsair III only. The maximum recommended distance between the Pulsair III and the remote unit is 16 ft., 5 in. (5 m).

Note: When converting a Pulsair III W or Z for use with a remote unit, some changes have to be done inside the positioner, see section 8.

Warning: In a hazardous environment where there is a risk of explosion, electrical connections must comply with the relevant regulations.

Terminal Blocks

The terminal blocks in the illustrations at right are accessible when the terminal cover is removed, see Section 8 for disassembly instructions.

Warning: In a hazardous environment where there is a risk of explosion, electrical connections must comply with the relevant regulations.

Pulsair III W

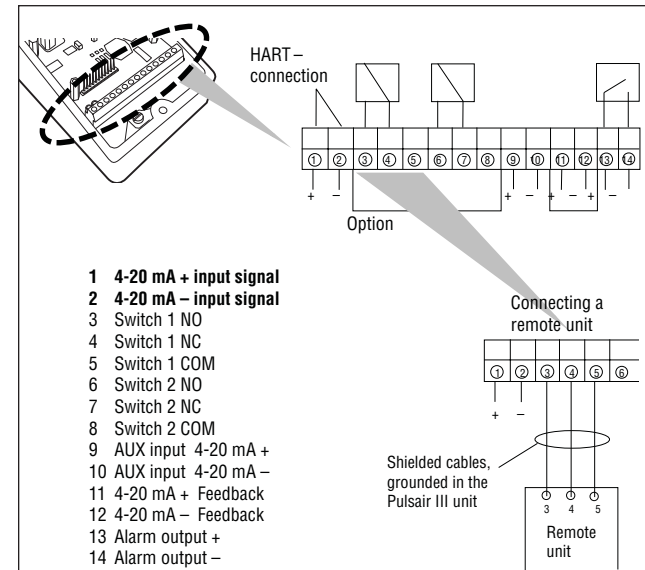

Pulsair III Z

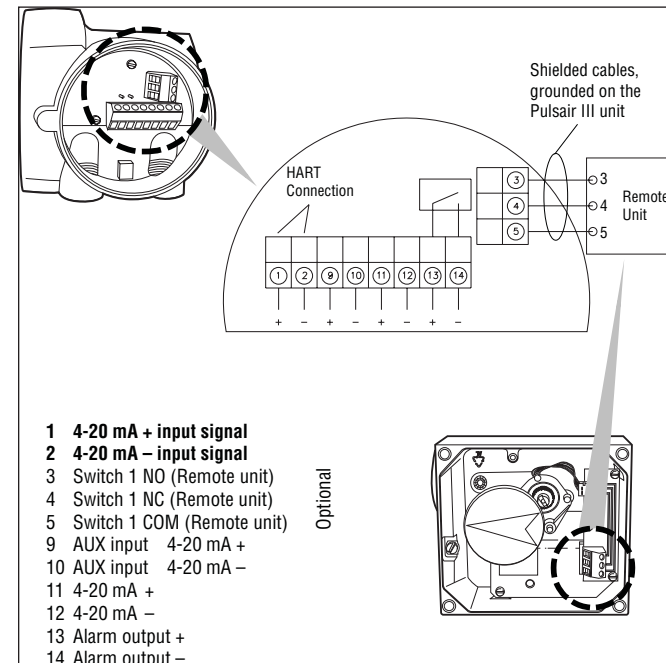

7 Control

Menu and Pushbuttons

The positioner is controlled using the five pushbuttons and the display, which are accessible when the aluminium cover is removed.

For normal functioning, the display shows the current value. Press the ESC button for two seconds to display the main menu.

Use the up and down pushbuttons to browse through the main menu and the submenus.

The main menu is divided up into a basic menu and a full menu, see the flowchart in the section, "The Menu System."

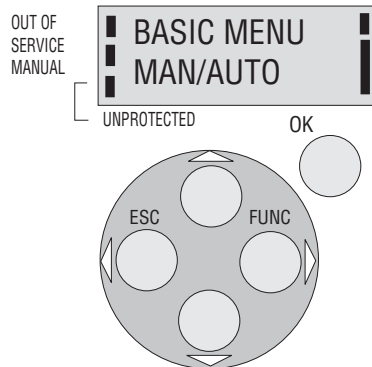

Other Functions

ESC: Exit the menu without making any changes (as long as any changes have not been confirmed with OK).

FUNC: To select functions and change parameters.

OK: To confirm selection or change of parameters.

MENU INDICATOR: Displays the position of the current menu row in the menu.

IN SERVICE: The positioner is following the input signal. This is the normal status when the positioner is working.

OUT OF SERVICE: The positioner is not following the input signal. Critical parameters can be changed.

MANUAL: The positioner can be adjusted manually using the pushbuttons. See Man/ Auto section.

UNPROTECTED: Most of the parameters can be changed when the positioner is in the "Unprotected" position. However, critical parameters are locked when the positioner is in the "In service" position.

Menu Indicator

There are indicators at both sides of the display window and they indicate as follows:

- Flashing in position **Out of service**
- Flashing in position **Manual**
- Displayed in position **Unprotected**

The indicators on the right-hand side show the position in the current menu.

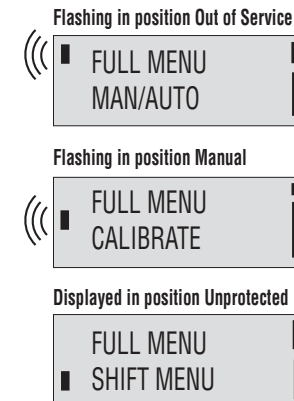

Menus

To display the menu you can select:

- **Basic menu**, which means you can browse through four different steps
- **Full menu**, which comprises ten steps. Use the Shift Menu to browse through the steps.

Full Menu can be locked out using a passcode.

The main menus and submenus are shown on the subsequent pages.

Changing Parameter Values

Change by pressing the left and right arrows until the desired figure is flashing.

Press the up and down arrows to step to the desired figure. Confirm by pressing OK.

A change can be undone by pressing the ESC button, which returns you to the previous menu.

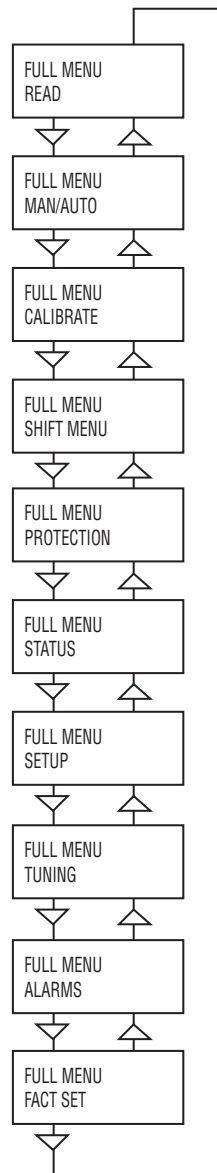
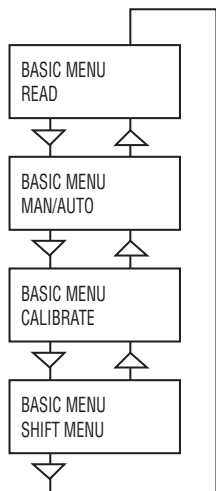

Basic Menu: Calibrate



First Start

Calibrate in the basic menu is displayed automatically the first time the positioner is connected, and can be selected from the basic/main menu at any later time.

A complete calibration takes about three minutes and includes end limit calibration, auto-tuning, leak test, and a check on the speed of movement. Start the automatic calibration by selecting Auto-Cal and then answer the questions on the display by pressing OK or the respective arrow. The menu is described later in this section.

Calibration Error Messages

If a fault occurs during the calibration, one of the following error messages will be displayed:

Invalid movement/press ESC to abort

No movement because the air is incorrectly connected, for example. After the fault is corrected, the calibration sequence must be restarted.

Pot unaligned/press ESC to abort

The potentiometer has been set to an illegal value. The potentiometer is aligned using the Calibrate - Expert cal - pot Menu. The calibration sequence must be restarted after the fault is corrected.

Air leak detected/ESC = abort OK = go on

An air leak has been detected. The calibration sequence should be restarted after the fault is corrected.

Increase C- damper/ESC = abort OK to retry

Increase C+ damper/ESC = abort OK to retry

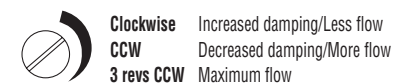

C+
(C-)

NOTE: Too much increased damping (low flow) might cause irregular actuator function.

Speed of movement is too fast. Adjust with the damper screws. Press OK. Repeat the adjustment and press OK until the speed is correct. If there is an abort, the calibration sequence must be restarted.

The contents of the menu are shown on subsequent pages. The various menu texts are described below.

Auto-Cal Auto-tuning and calibration of end positions

Start tune Starts the tuning. Questions/commands are displayed during calibration. Select the type of movement, function, etc. with the down arrow and confirm the OK as shown in the chart on the next page.

Lose prev value? OK? A warning that the value set previously will be lost (not during the first auto-tuning).

Actuator? Rotating Select for rotating actuator.

Actuator? Linear Select for linear actuator.

Actuator single act Select for single-acting.

Actuator double act Select for double-acting.

Direction? direct Select for direct function.

Direction? reverse Select for reverse function.

In service? Press OK Calibration finished. Press OK to start positioner functioning. (If ESC is pressed, the positioner assumes the “Out of service” position but the calibration is retained).

TravelCal Calibration of end position

Start cal Start end position calibration

Lose prev value? OK? A warning that the previously set value will be lost. Confirm with OK. The calibration sequence starts.

In service? Press OK Calibration finished, Press OK to start positioner functioning. (If ESC is pressed, the positioner assumes the “Out of service” position but the calibration is retained).

Perform Setting gain

Normal 100% gain

Perform 50%, 25%, 12%, L, M, S Possibility to select a lower gain in steps

L, M, S Preset values for L, M, S actuators

Factory set Resets all set values and enters Factory Mode. Should only be used by authorized staff.

Note: Original P.I.D. will always be shown in display.

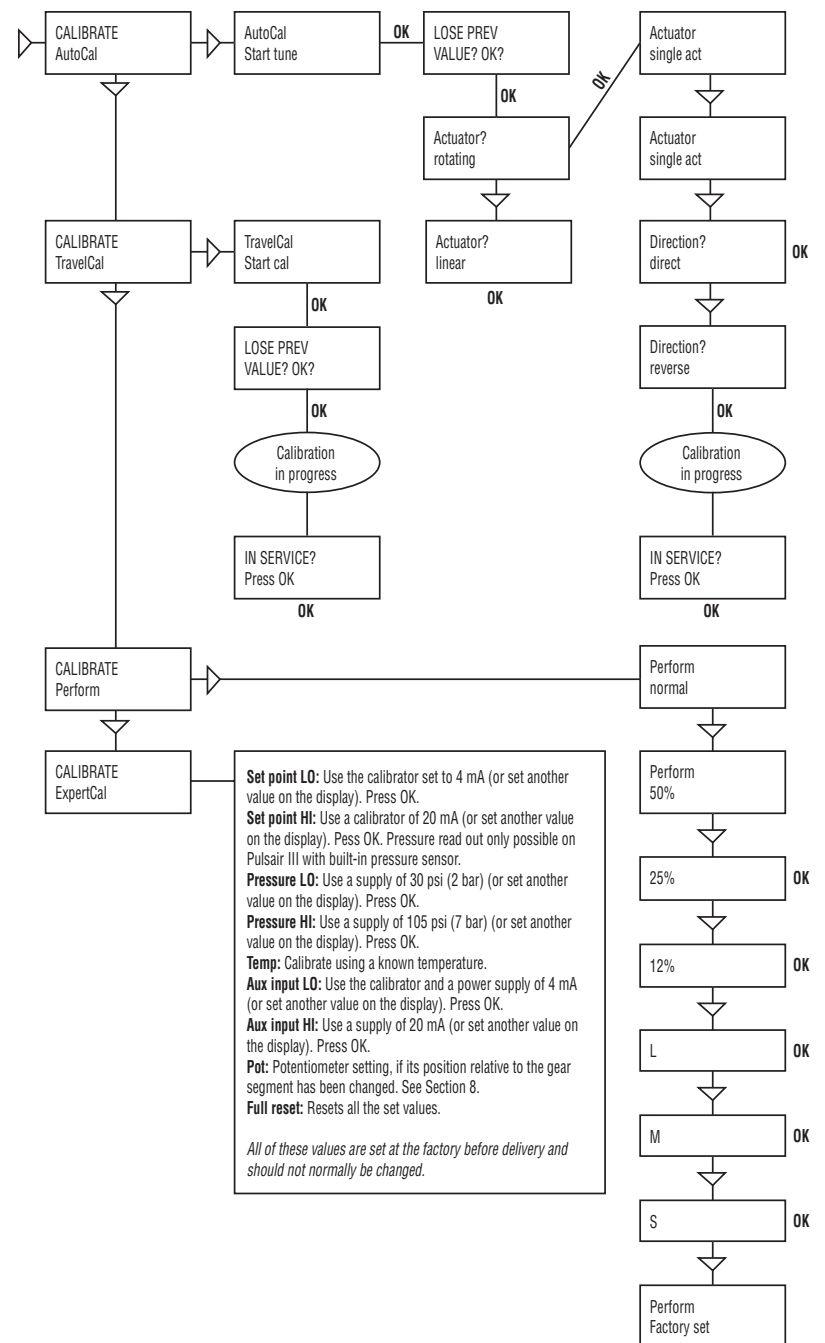

Basic Menu: Read

The menu contents are shown in the figures on the right and the steps are described below:

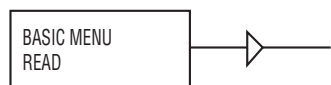

Current values can be read using the Read Menu and some values can be reset.

Pos Shows current position

Set&pos Set point and position

Set&dev Set point and deviation

Temp Shows current temperature

Aux Shows aux input signal value. External pot or similar.

Statistics

n cycles Shows number of movements (turns)

Acc travel Shows accumulated movement

mean dev Shows accumulated deviation in %

runtime Shows accumulated runtime since last reset

extr temp Shows extreme min and max temperature

Histogram Shows position and time for PV

Alarms Displays tripped alarms

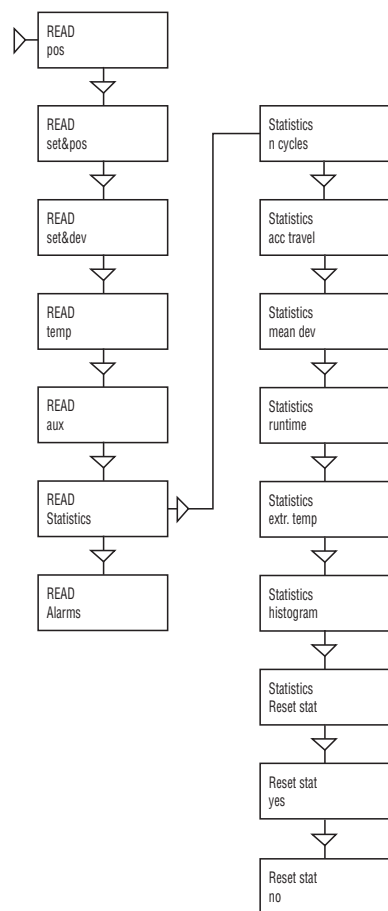

Basic Menu: Man/Aut

The Man/Auto menu is used to change between manual and automatic modes.



The menu contents are shown in the figures below and the various texts are described below:

AUT, OK = MAN Positioner in automatic mode

MAN, OK = AUT Positioner in manual mode

In the MAN mode, the value of POS can be changed using the up and down arrows. The pushbuttons increase/decrease the value in steps. The value can also be changed in the same way as for the other parameter values, as previously described.

Other Functions

C+ can be fully opened by first pressing the up arrow and then immediately OK simultaneously.

C- can be fully opened by pressing the down arrow and OK simultaneously.

C+ and C- can be fully opened for blowing clean by pressing the up and down arrows and OK simultaneously.

When changing between MAN and AUT mode, the OK button must be depressed for three seconds.



Basic Menu: Shift Menu

The Shift Menu is used to choose between the basic menu and the full menu.



The menu contents are shown in the figures below and the various steps are described below:

No Full menu selected.

Yes Basic menu selected.

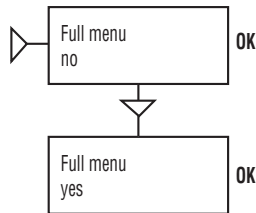

Full Menu can be locked with a passcode, see the SETUP Menu section.

Full Menu: Protection

The Protection menu is used to protect all essential settings.

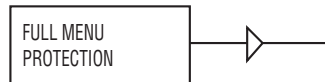

The menu contents are shown in the figures below and the various steps are described below:

No Entered values are not write-protected. "Unprotected" is displayed in the lower left-hand corner.

Yes Entered values are write protected. Passcode needed for change to No (Applicable when a passcode has been set up in SETUP menu).

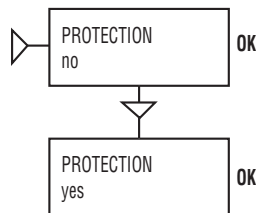

When changing between Yes and No mode, the OK button must be depressed for three seconds.

Full Menu: Status

The Status Menu is used to select whether or not the positioner is in service.



The menu contents are shown in the figures below and the various texts are described below:

o o service Not in service. Flashing indicator in upper left-hand corner of display.

in service Positioner in service. Critical parameters cannot be changed.

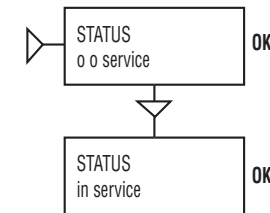

When changing between In service and Out of service, the OK button must be depressed for three seconds.

Full Menu: Setup

The Setup Menu is used for various settings.

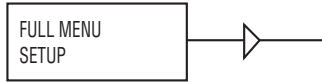

The menu contents are shown in the chart on subsequent pages and the various texts are described below:

Actuator	Type of Actuator
Rotating	Rotating actuator
Linear	Linear actuator

Size of Actuator	Time Out
Small	10 s
Medium	25 s
Large	60 s
Texas	180 s

Lever Only for linear actuator.

Lever stroke Stroke length to achieve correct display

Level cal Calibration of positions to achieve correct display

Direction

Direct Direct function (signal increase opens). Indicator/spindle rotates counterclockwise.

Reverse Reverse function

Character

Curves that show position as a function of input signal.

Linear See diagram

Equal % See diagram

Quick open See diagram

Sqr root See diagram

Custom Create own curve.

Cust chr

of point Specify number of points (3, 5, 9, 17, or 33)

Cust curve Enter values on X and Y axes.

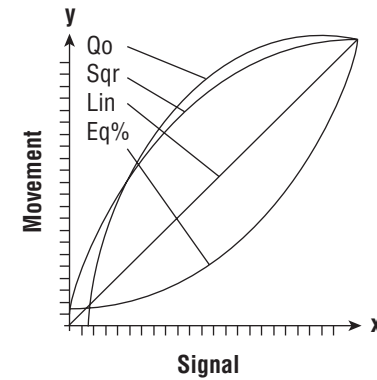

Curr range

0% = 4.0 mA

100% = 20.0 mA Possibility of selecting which input signal values will correspond to 0% and 100% movement respectively. Examples of settings:

- 4 mA = 0%
- 12 mA = 100%
- 12 mA = 0%
- 20 mA = 100%

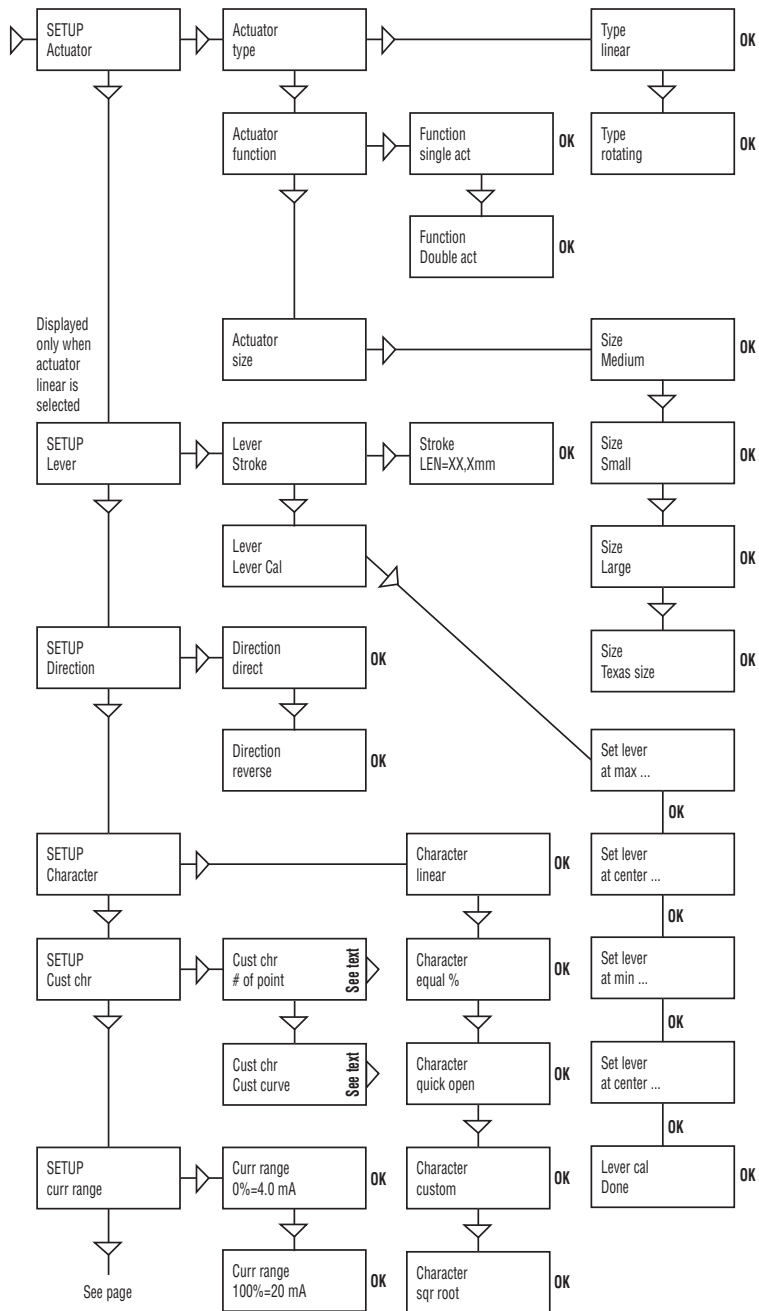

TRVL range Setting end positions

0% = 0.0% Select Out of Service. Set percentage value for desired end position (e.g. 3%).

Set 0% Select In Service. Connect calibrator. Move forward to desired end position (0%) and press OK.

100% = 100.0% Select Out of Service. Set percentage value for desired end position (e.g. 100%).

Set 100% Select In Service. Connect calibrator. Move forward to desired end position (100%) and press OK.

TRVL ctrl Behavior at set end position

Set low Choose between Free (go to mechanical stop), Limit (stop at set end position), and Cut off (go directly to mechanical stop at set end position).

Set high Similar to Set low.

Values Select position for Cut off and Limit at the respective end positions.

Passcodes Setting passcodes for various functions

Full menu Passcode for access to full menu.

Write prot Passcode for removing write protect.

Expert Passcode for access to Expert menu (TUNING).

Fact set Passcode to return to default values applicable when positioner was delivered.

Numbers between 0000 and 9999 can be used as passcodes. 0 = no passcode required.

Appearance On display

Language Select menu language.

Units Select units.

Def. Display Select value(s) to be displayed during service. The display reverts to this value 10 minutes after any change is made.

Start menu Start in Basic menu or Full menu.

Contrast Adjust display contrast.

Orient Orientation of text on display.

Par mode Display of control parameters such as P, I, D or K, Ti, Td.

Devicedata

HW rew General Parameters

SW rew General Parameters

Capability General Parameters

HART Menu with HART parameters. Only amendable with HART communicator. It is possible to read from display.

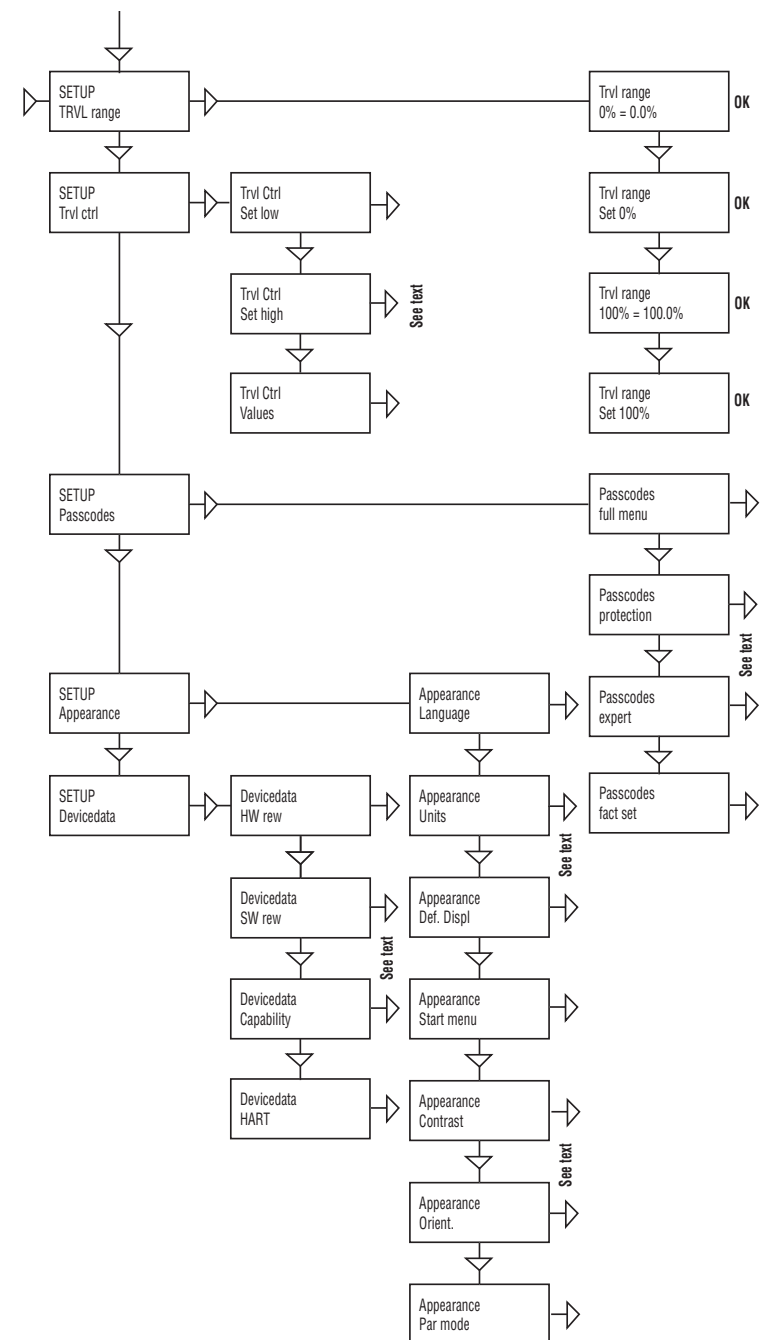

Full Menu: Tuning

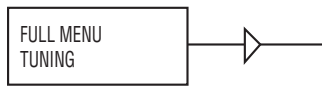

The **Tuning Menu** is used to further tune the operation and set parameters. The menu contents are shown in the chart and the various steps are described below:

Close time Minimum time from fully open to closed.

Open time Minimum time from closed to fully open.

Deadband Setting deadband. Minimum 0.2%

Expert Advanced settings.

Toggletester Test tool for checking functions. Overlays a square wave on the set value.

K, Ti, Td Setting K, Ti, and Td parameters.

Self test Test of processor, potentiometer, etc.

Leakage Air leakage detected can be either connections, positioner tubing or actuator.

Undo Read last 20 changes.

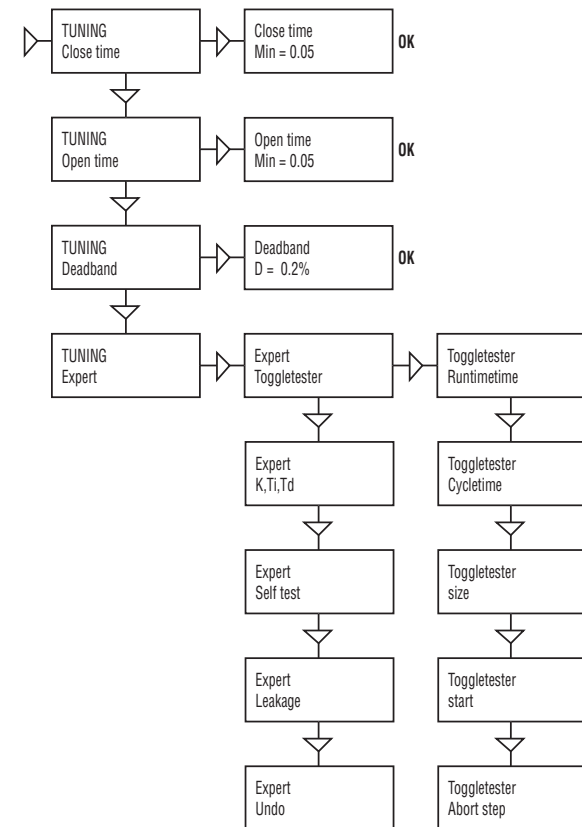

Full Menu: Alarms



The menu contents are shown in the chart and the various steps are described below:

Deviation Alarm generated when deviation occurs.

On/Off Alarm on/off.

Distance Allowed distance before alarm is generated.

Time Total deviation time before alarm is generated.

Alarm Out Select ON/OFF offers output on terminals 13 and 14.

Valve act Behavior of valve when alarm is generated.

Limit 1 Alarm above/below a certain level.

On/Off Alarm on/off. (See diagram below.)

Minipos Setting of desired minimum position. (See diagram below.)

Maxpos Setting of desired maximum position. (See diagram below.)

Hysteresis Desired hysteresis. (See diagram below.)

Alarm on Select ON/OFF offers output on terminals 13 and 14.

Valve act Behavior of valve when alarm is generated.

Limit 2 See Limit 1.

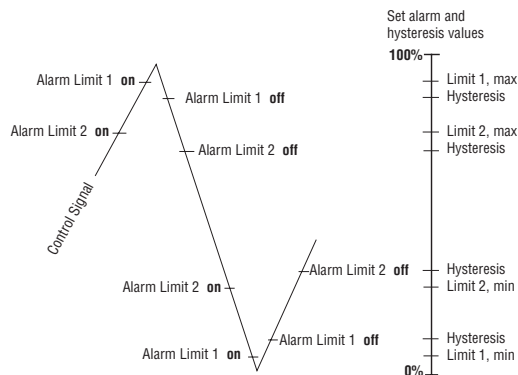

Pos=aux External potentiometer

On/Off Function on/off.

Max diff Maximum allowed deviation between the internal and external potentiometers.

Alarm Out Select ON/OFF offers output on terminals 13 and 14.

Valve act Behavior of valve when alarm is generated.

Aux input External input signal 4-20 mA.

On/Off* Alarm on/off

Minipos* Setting of desired minimum position

Maxpos* Setting of desired maximum position

Hysteresis* Desired hysteresis

Alarm Out Select ON/OFF offers output on terminals 13 and 14.

Valve act Behavior of valve when alarm is generated.

* Function similar to Limit 1 and Limit 2. See Limit 1 and Limit 2 sections.

Temp Alarm based on temperature

On/Off Temperature alarm on/off.

Low temp Low temperature setting.

High temp High temperature setting.

Hysteresis Allowed hysteresis.

Alarm Out Select ON/OFF offers output on terminals 13 and 14.

Valve act Behavior of valve when alarm is generated.

No action Alarm generated only. Operation not affected.

Goto open C+ gives full pressure and valve moves to fully open position. Positioner changes to position Manual.

Goto close C- gives full pressure and valve moves to fully closed position. Positioner changes to position Manual.

Manual Valve stays in unchanged position. Positioner moves to position Manual

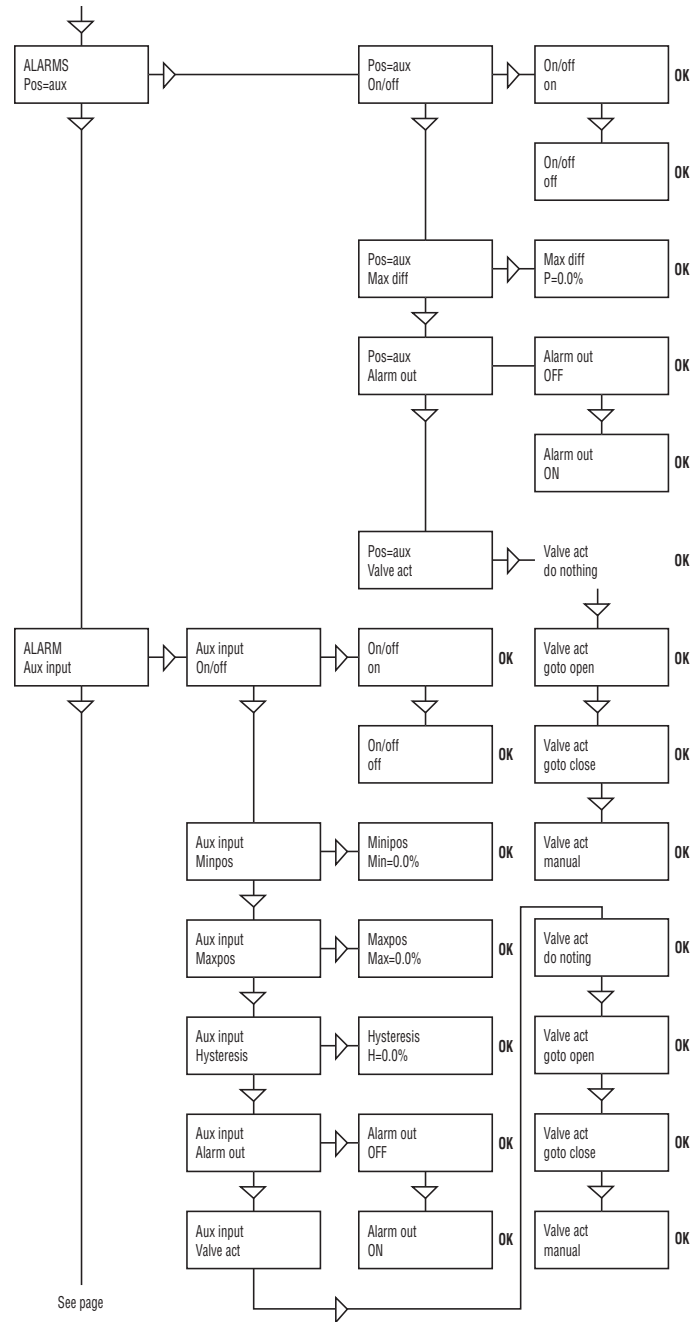
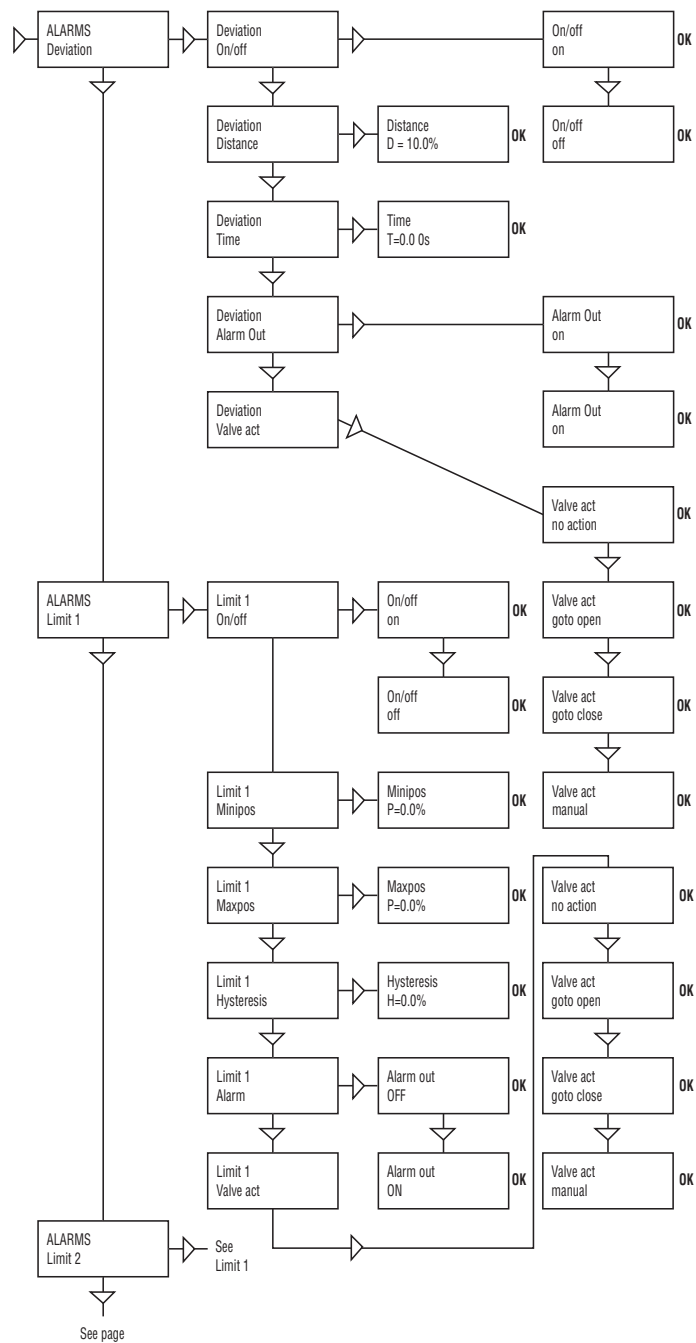

Full Menu: Fact Set

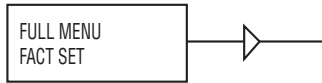

The menu contents are shown in the chart and the various steps are described below:

The default values that were set on delivery can be reset using the Fact Set menu. Values from later calibration and from other settings will be lost.

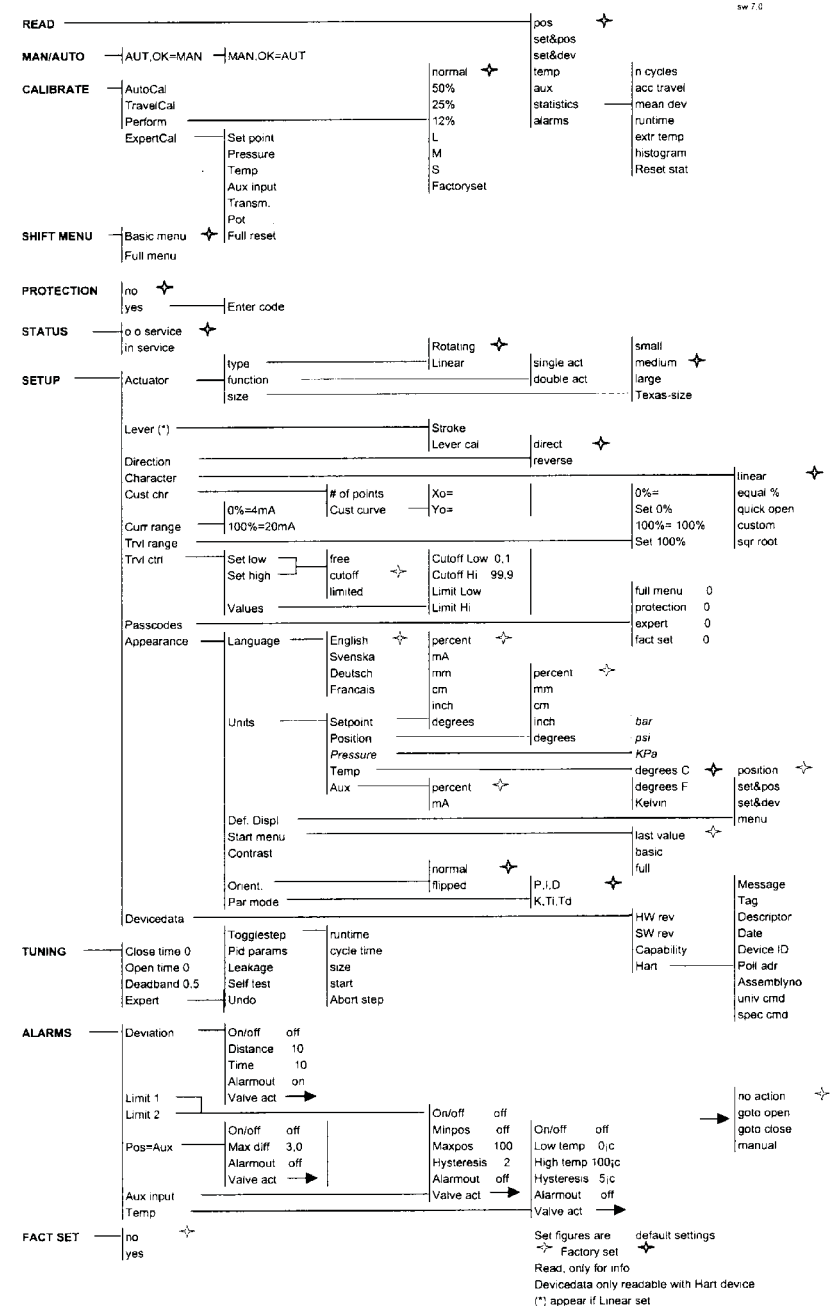
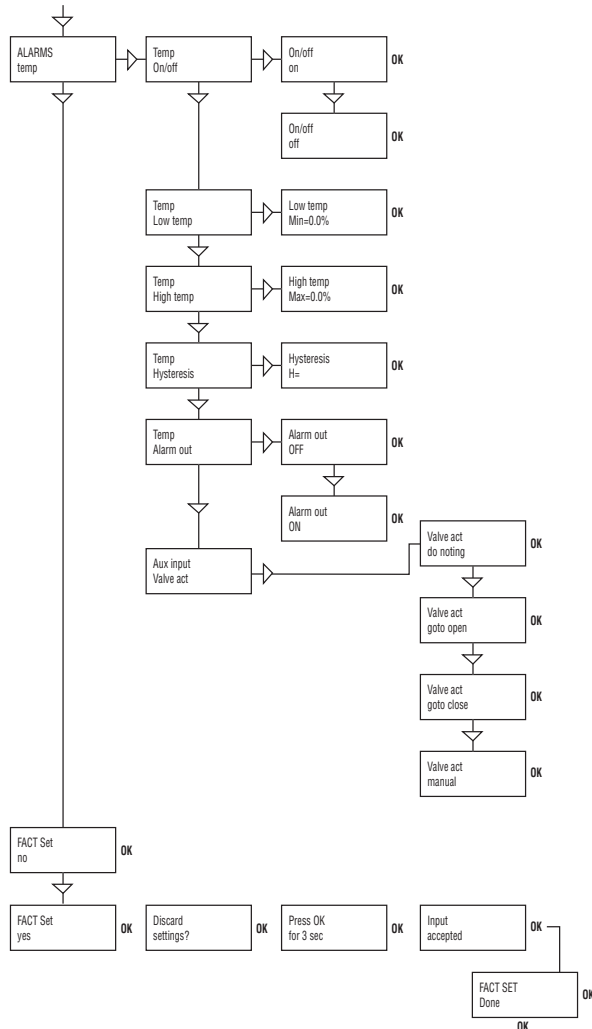

8 Maintenance/Service

When carrying out service, replace a circuit board, etc., it may be necessary to remove and refit various parts of the positioner. This is described on the following pages.

Note: Read the Safety Instructions on page 3 before starting work on the positioner.

Note: Cleanliness is essential when working with the positioner. Contamination in the air ducts will inevitably lead to operational disturbances. Do not disassemble the unit more than that described here.

Note: Do not take the valve block apart because its function will be impaired.

Note: When working with the Pulsair III positioner, the work place must be equipped with ESD protection before the work is started.

▲ Warning: Always turn off the air and electrical supplies before starting any work.

Disassembling Pulsair III W

Removing cover and inner cover

1. Unscrew the screws A and remove the cover.

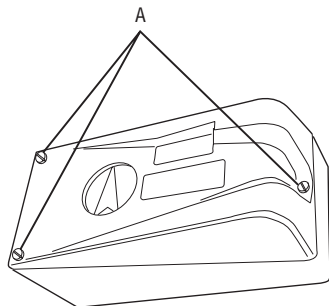

2. Pull off the disc with the arrow B.

3. Unscrew the screws C, pull the inner cover slightly in the direction of the arrow, and remove the cover.

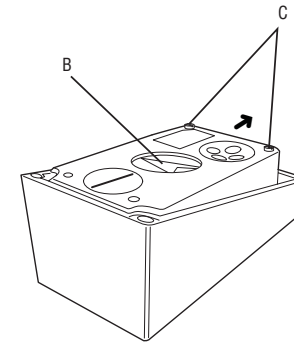

Circuit Boards (pcb)

▲ Warning: Disconnect or switch off the power supply before starting any work.

1. Lift off the display pcb D.

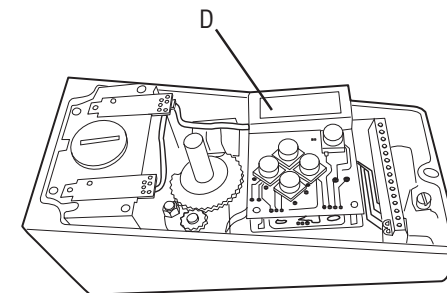

2. Unscrew the spacers E, release the cable connections F and G, and lift up the processor pcb.

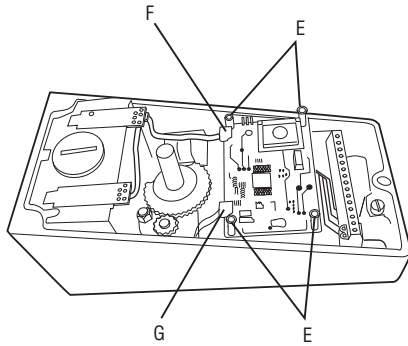

3. Remove the terminal board by unscrewing the spacers H.

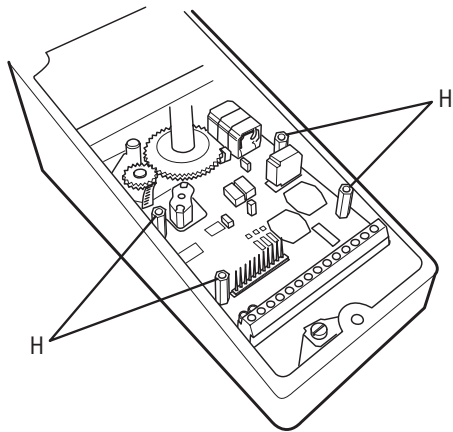

Valve Block

▲ Warning: Turn off the air and power supply before starting any work.

1. Release the connector F from the processor pcb.
2. Remove the four screws I.

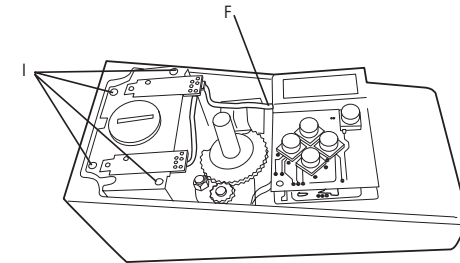

3. Lift out the valve block.

Note: Do not disassemble the valve block.

4. When installing the valve block, torque the four screws to 12.4 in-lb (1.4 Nm) and seal with Locktite 222.

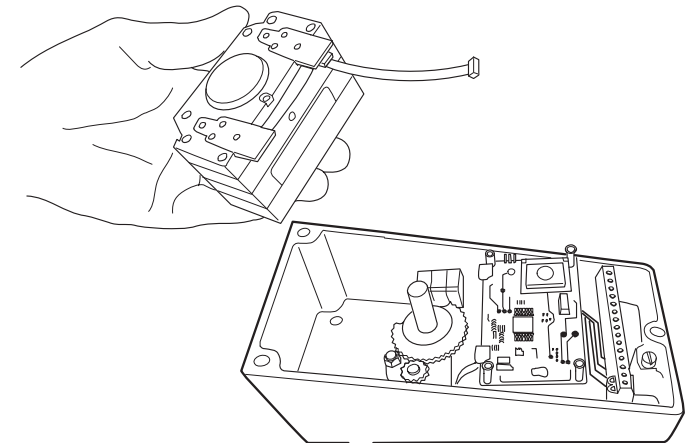

Silencer

An optional silencer, L can be mounted under the plate M on the Pulsair III. Contact Flowserve.

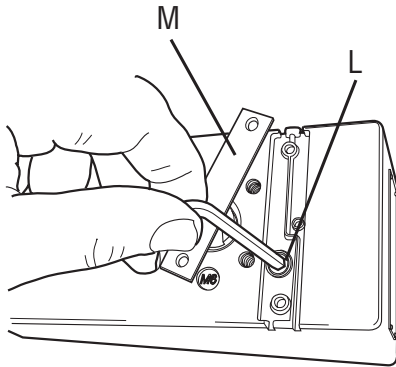

Spindle Adapter

The spindle adapter can be changed to suit the actuator in question, see the Mounting section.

Potentiometer

90° and 270° spring-loaded potentiometer

The spring-loaded potentiometer K can be removed from the gearwheel for calibration or replacement.

If the potentiometer is replaced or the setting is changed, it must be calibrated.

1. Select the menu Calibrate - Expert - Cal pot. The display shows Set gear (1).
2. Press the down arrow to rotate the spindle shaft (2) CW to the end position and press OK.
3. The display will indicate the direction to rotate the potentiometer. Unmesh the potentiometer (3) and turn it according to display until OK is shown. Press OK.
4. Press the up arrow button to rotate the spindle shaft (2) CCW to the end position and press OK.

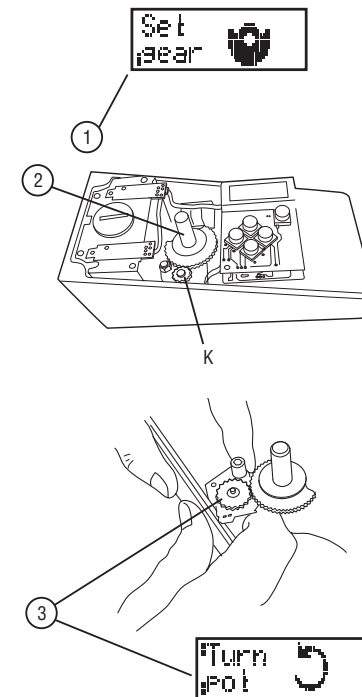

Transmitter Boards

The equipment for transmitter feedback consists of a circuit board A, cam assembly B and screws.

The circuit board exists in four versions:

- with mechanical switches, SPDT
- with NAMUR sensors, DIN 19234
- with proximity switches
- with feedback transmitter only

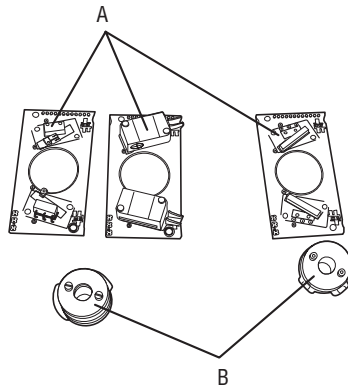

Transmitter Board Installation

⚠ Caution: Turn off the power and air supply starting the installation.

Important for Pulsair III intrinsically safe units: Transmitter boards NOT for onsite mounting by customer. FM, CSA and ATEX certificate only valid when transmitter board is mounted by manufacturer.

1. Remove the cover, indicator, and inner cover according to the description previously mentioned in this section.

2. Check that both spacers C are installed.

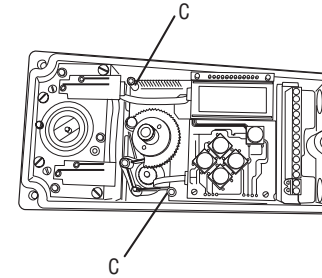

3. Carefully mount the circuit board in its position. The pins D should fit in the connector and the positioners motherboard. Make sure that the feedback PC board is properly connected.

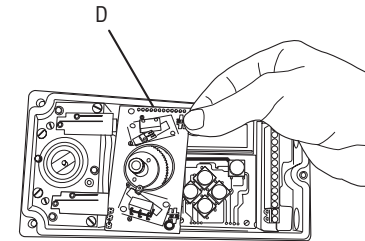

4. Secure the circuit board with the enclosed screws E.

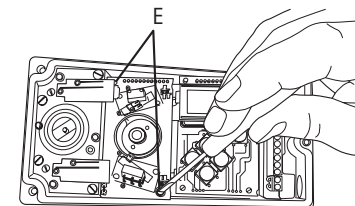

5. Install the cam assembly B on the shaft and push it down to its position. If the board has microswitches, be careful not to damage the levers.

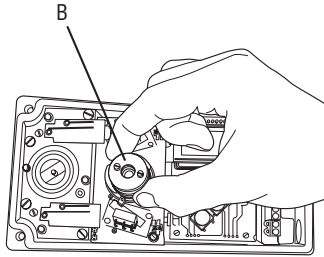

6. Tighten the screws F, on the cam assembly. Do not over tighten the screws. The cams should be able to move in relation to each other.

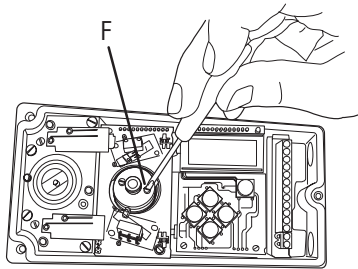

7. Install the inner cover with the two screws, G.
8. Connect the wiring for the transmitter feedback on the terminal block according to the drawing on the next page.

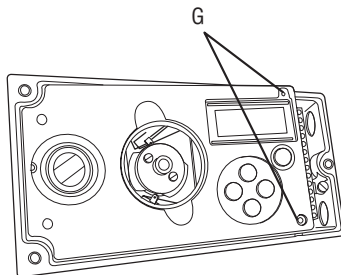

9. Adjust the position where the switches/sensors should be affected by turning the cams with a screwdriver.

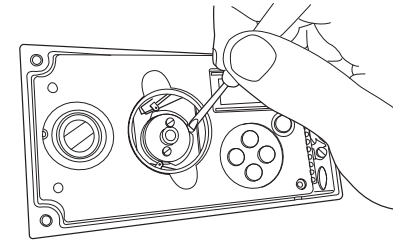

10. Tighten the cam assembly screws F when the cams are correctly adjusted.
11. Install the indicator and cover. To calibrate the feedback transmitter, see the drawing on the next page.

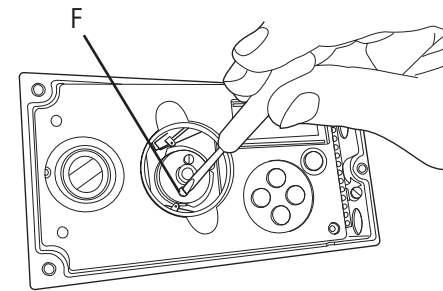

Calibration

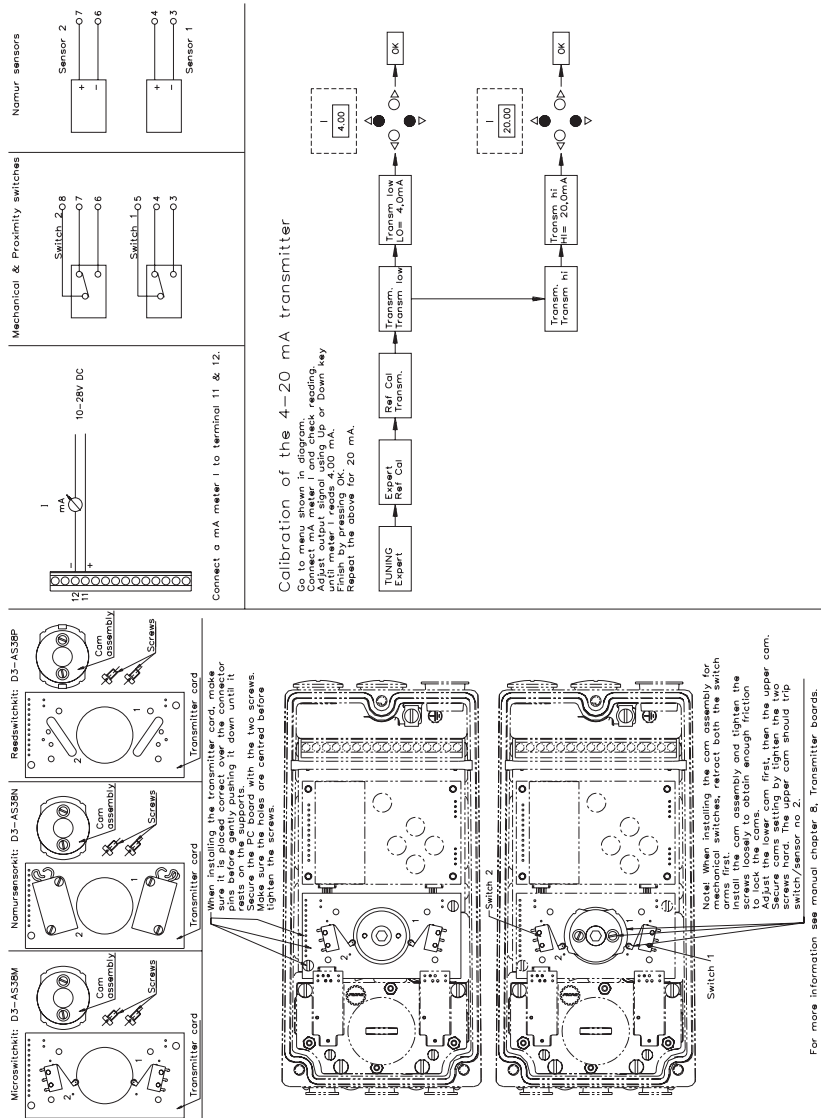

Disassembling the Worcester Pulsair III Z

1. Loosen the screws A and B and remove the caps C and D.
2. Remove the inner display cover E by loosening the four screws F.
3. Carefully remove the display board and loosen the connections H and I.

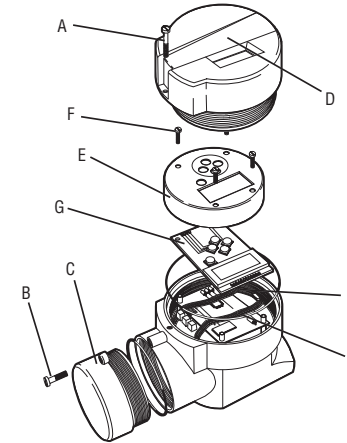

4. Release the wide cable from the connector J on the terminal board.
5. Loosen the three screws K.
6. Remove the circuit board package L, consisting of the terminal and processor board.
7. Remove the four screws M and and lift the block N.

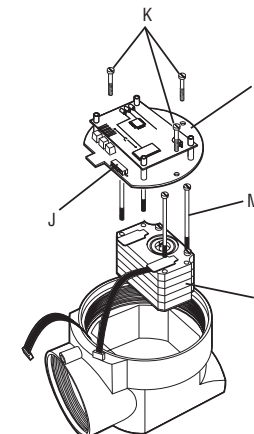

Filter Change, Pulsair III W and Z

▲ Warning: Turn off the compressed air supply before starting any work. Otherwise the filter can be uncontrollably blown out of the positioner by the air pressure, which can be dangerous.

- Remove the filter cap using a coin of suitable size.

Note: Do not use a screwdriver. The filter cap might crack and cause air leakage.

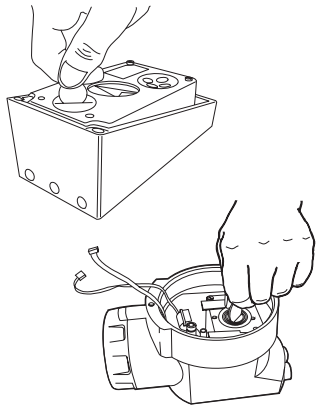

Converting for Remote Control

▲ Warning: Disconnect or switch off the power supply before starting any work.

1. Remove cover and inner cover, see instructions earlier in this section.
2. Lift off the display pcb, D.

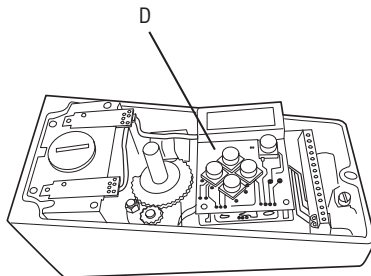

3. Disconnect and secure the potentiometer cable.
4. Install transmitter board D3-AS38T, F.

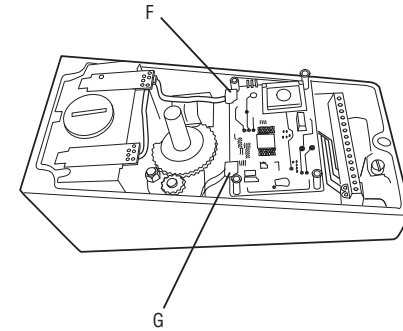

5. Install the enclosed wire between G and O.
6. Connect the wiring between terminals 3, 4, 5 in the W unit and 3, 4, 5 in the remote unit.

Use a shielded wire and ground it in the W unit only.

Avoid distances more than 16 ft. (5 m) between W unit and remote unit.

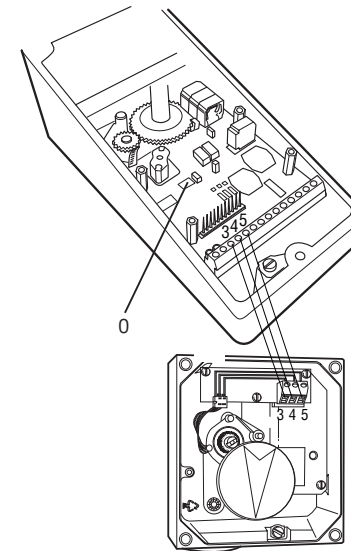

9 Troubleshooting

Change in input signal to positioner does not affect actuator position.

- Check air supply pressure, air cleanliness, and connection between positioner and actuator.
- Check input signal to positioner.
- Check mounting and connections of positioner and actuator.

Change in input signal to positioner makes actuator move to its end positioner.

- Check input signal.
- Check mounting and connections of positioner and actuator.

Inaccurate regulation.

- Implement auto-tuning. Check for any leaks.
- Uneven air supply pressure.
- Uneven input signal.
- Incorrect actuator size for application.
- High friction in actuator/valve package.
- Excess play in actuator/valve package.
- Excess play in mounting of positioner on actuator.
- Dirty/humid supply air.

Slow movements, unstable regulation.

- Implement auto-tuning.
- Adjust the pressure adjusting screws.
- Increase the deadband (Tuning menu).
- Adjust Performance (Calibrate menu).

10 Technical Data

Rotation angle: min. 30°, max. 100°

Stroke: 0.2" to 5.1" (5-130 mm)

Input signal: 4-20 mA

Air supply: 30-87 psi (2-7 bar) Free from oil, water, and moisture. Filtered to minimum 30 micron

Air delivery: 13.8 scfm (400 nl/min)

Air consumption: 0.01 scfm (<0.3 nl/min)

Air connections: ¼" G or NPT

Cable entry: 3 x M20 or ½" NPT

Electrical connections: Screw terminals 2.5 mm² / AWG14

Linearity: <1%

Repeatability: <0.5%

Hysteresis: <0.4%

Deadband: 0.2-10% adjustable

Display: Graphic, view area 0.6" x 1.6"
(15 x 41 mm)

UI: 5 pushbuttons

Processor: 16 bit, M 16C

CE directives: 93/68/EEC, 89/336/EEC, 92/31/EEC

EMC: EN 50 081-2, EN 50 082-2

Voltage drop: <10.1 V

Vibrations: <1% up to 10 g at frequency 10-500 Hz

Enclosure: IP66/NEMA 4X

Material: Die-cast aluminium, A2/A4 fasteners

Surface treatment: Powder epoxy

Temperature range: -22 to 176°F (-30 to +80°C)

Weight: W, 3 lb. (1.4 kg) Z, 6.6 lb. (3 kg)

Alarm output: Transistor Ri 1k Ω

Alarm Supply Voltage: 8-28 V

Mechanical Switches

Type: SPDT
 Size: Sub Sub miniature
 Rating: 3 A/125 VAC; 2 A/30 VDC

NAMUR Sensors

Type: Proximity DIN 19234 NAMUR
 Load current: ≤ 1 mA ≤ 3 mA
 Voltage range: 5-25 VDC
 Hysteresis: 0.2%
 Temp: -4°F to 185°F (-20°C to 85°C)

Proximity Switches

Type: SPDT
 Rating: 5 W/250 mA/30 VDC/125 VAC
 Operating time: 0.7 ms
 Breakdown voltage: 200 VDC
 Contact resistance: 0.1 Ω
 Mechanical/electrical life: $>50 \times 10^6$ operations

4-20 mA Transmitter

Supply: 9-28 VDC
 Output: 4-20 mA
 Resolution: 0.1%
 Linearity full span: $\pm 0.5\%$
 Output current limit: 30 mA DC
 Load impedance: 800 Ω @ 24 VDC

Dimensions – in. (mm)

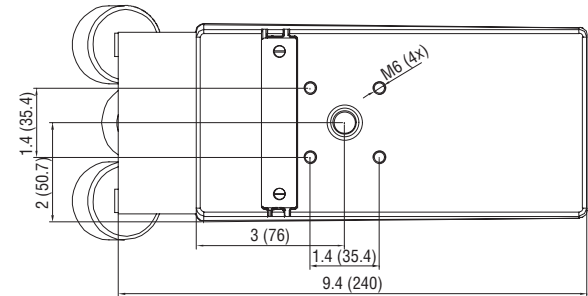
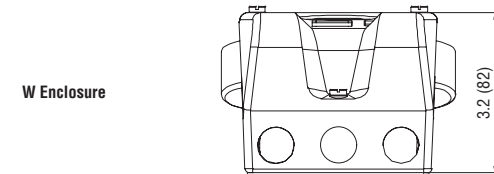
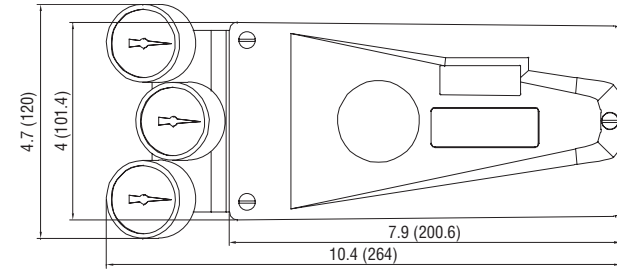

Z Enclosure

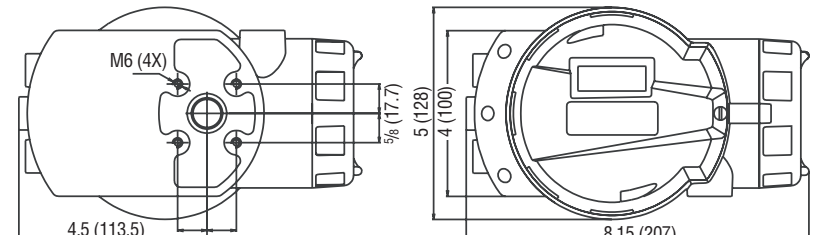

11 Spare Parts

Pulsair III W

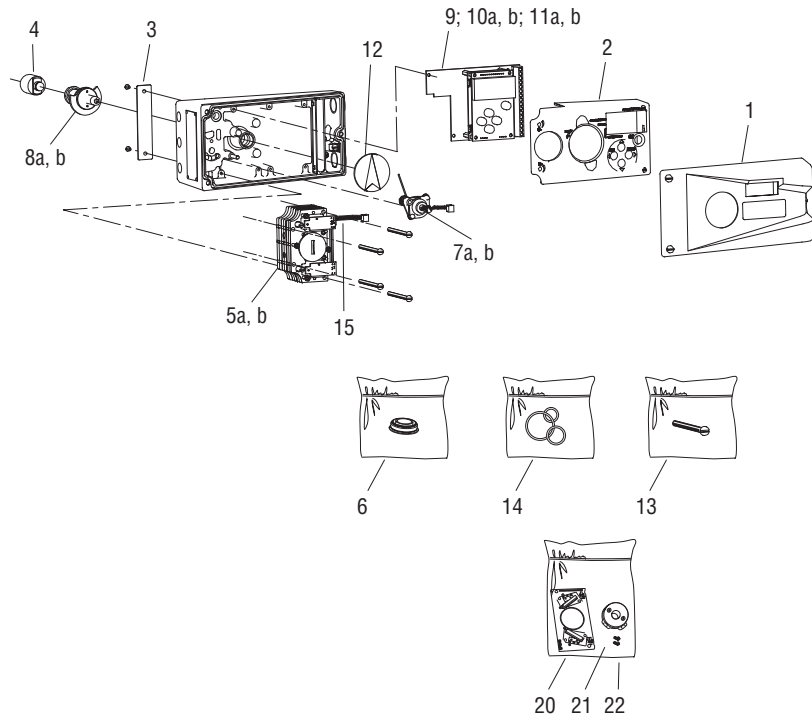

Part	Description
1	Cover including screws
2	Internal cover including screws
3	Cover plate including screws
4	Spindle adapter
5a	Block compl including cable, rubber seal, filter-plug
5b	Block compl including cable, rubber seal, filter-plug IS
6	Filter-plug including O-ring, filter
7a	Potentiometer including spring, holder, cable
7b	Potentiometer including spring, holder, cable, 270°
8a	Shaft including gearwheel, friction clutch
8b	Shaft including gearwheel, friction clutch, 270°
9	Display pcb
10a	All pcbs (terminal block, processor, display)
10b	All pcbs (terminal block, processor, display) IS
11a	All pcbs HART (terminal block, processor, display)
11b	All pcbs HART (terminal block, processor, display) IS
12	Arrow pointer
13	Kit, bag with screws
14	Kit, bag with O-rings, seals
15	Cable, pneumatic block including 2xPCB
16a	Dump valve G (not shown)
16b	Dump valve NPT (not shown)
17	Gauge block G (not shown)
18	Gauge block NPT (not shown)
19	Silencer (not shown)
20	Transmitter board, Mechanical
21	Transmitter board, NAMUR
22	Transmitter board, Proximity
23	Remote cable, potentiometer (not shown)

Pulsair III Z

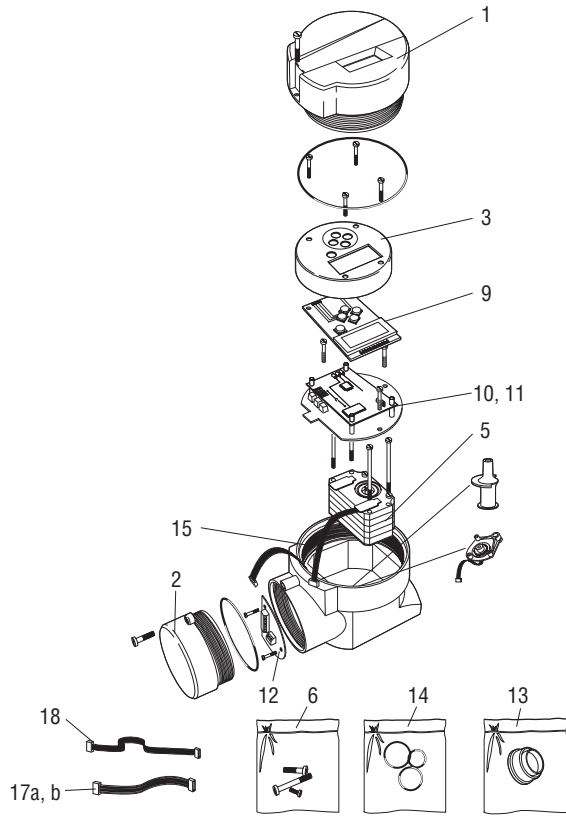

Part	Description
1	Cover including screws
2	Terminal cover including screws
3	Internal cover including screws
4	Spindle adapter (not shown)
5	Block including cable, rubber seal, filter-plug
6	Filter plug including O-ring, filter
7	Potentiometer including spring, holder, cable
8	Shaft including gearwheel, friction clutch
9	Display pcb
10	Mother PCB and processor PCB
11	Mother PCB and processor PCB, HART
12	Terminal PCB including cable
13	Kit, bag with screws
14	Kit, bag with O-rings
15	Cable, pneumatic block
16a	Dump valve G (not shown)
16b	Dump valve NPT (not shown)
17a	Connection block G
17b	Connection block NPT
18	Remote cable (potentiometer)
19	Piezokablage (not shown)



United States

Flowserve Corporation
Worcester Controls
1978 Foreman Drive
Cookeville, TN 38501 USA
Telephone: 931-432-4021
Fax: 931-432-5518

FCD WCAIM2056-00 Printed in USA. (Replaces IOM-19990)

To find your local Flowserve representative:

For more information about Flowserve Corporation, visit
www.flowserve.com or call USA 1 800 225 6989

Flowserve Corporation has established industry leadership in the design and manufacture of its products. When properly selected, this Flowserve product is designed to perform its intended function safely during its useful life. However, the purchaser or user of Flowserve products should be aware that Flowserve products might be used in numerous applications under a wide variety of industrial service conditions. Although Flowserve can (and often does) provide general guidelines, it cannot provide specific data and warnings for all possible applications. The purchaser/user must therefore assume the ultimate responsibility for the proper sizing and selection, installation, operation, and maintenance of Flowserve products. The purchaser/user should read and understand the Installation Operation Maintenance (IOM) instructions included with the product, and train its employees and contractors in the safe use of Flowserve products in connection with the specific application.

While the information and specifications contained in this literature are believed to be accurate, they are supplied for informative purposes only and should not be considered certified or as a guarantee of satisfactory results by reliance thereon. Nothing contained herein is to be construed as a warranty or guarantee, express or implied, regarding any matter with respect to this product. Because Flowserve is continually improving and upgrading its product design, the specifications, dimensions and information contained herein are subject to change without notice. Should any question arise concerning these provisions, the purchaser/user should contact Flowserve Corporation at any one of its worldwide operations or offices.

© 2004 Flowserve Corporation, Irving, Texas, USA. Flowserve is a registered trademark of Flowserve Corporation.