

Mechanical Seal Guidelines for the Corn Processing Industry



Introduction

Corn is one of the major crops grown by American farmers. While corn is grown in other countries, the United States is the single major corn producer in the world surpassing the nearest grower country by a factor of two to three times as much. Corn yield in any growing season depends on weather conditions but an average growing year will usually produce between 9 and 10 billion American bushels.¹

Approximately 60% or about three out of every five bushels harvested is used directly as feed for livestock, poultry, and fish. About 20% is exported and about 5% is used to produce cereals and provide seed stock for subsequent crops.² The remaining 15% is transported to corn processing plants where it is milled to produce corn syrups, sweeteners, oils, starches, ethanol, and processed animal foods.³ These corn bi-products are important components used in many subsequent food and industrial products marketed worldwide.

Some examples of corn bi-product use include:

- Foods* - mayonnaise, baby foods, breads, soups, sauces, snacks, and other food types.
- Drinks* - soft drinks, juices, beer, alcohol, and other beverages in need of a sweetener.
- Confectioneries* - fruit fillings, dairy creams, ice creams, marmalades, and similar sweets.
- Textiles* - yarns and warp threads.
- Papers* - printing papers, cardboard, corrugated boards, and other paper products.
- Other Products* - glues, detergents, stain removers, baby diapers, and other uses.
- Other Industries* - foundries, water treatment, animal feeds, and bio diesel fuels.

The main driver for these processing needs has been the increased consumption of corn syrups as economical substitutes for sugar in processed foods and soft drinks. The increases in corn usage over a 20 year period to make these corn syrups are shown in Figure 1.⁴

¹ U.S. Corn Production: 1999-2001 Corn Refiners Association, <http://www.corn.org/web/uscprod.htm>, (Reproduced with permission of Corn Refiners Association, Inc.)

² Frequently Asked Questions, Corn Refiners Association, <http://www.corn.org/web/faq.htm>, (Reproduced with permission of Corn Refiners Association, Inc.)

³ The Process (step-by-step), Corn Refiners Association, <http://www.corn.org/web/process.htm>, (Reproduced with permission of Corn Refiners Association, Inc.)

⁴ Food and Industrial Corn Use-1980 to Present, Corn Refiners Association, <http://www.corn.org/web/foodseed.htm>, (Reproduced with permission of Corn Refiners Association, Inc.)

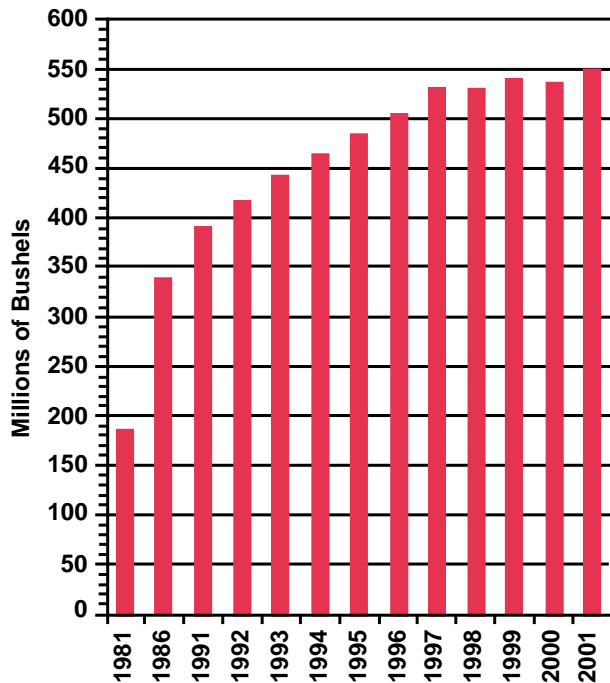

As the need for processed corn products has expanded from about 10.2% of net yield in 1982 to about 24.9% in 2002,⁵ developments in organic chemicals, bio-based products, and renewable energies will require greater use of processed corn products. The most promising of these new markets will be as raw stock for industrial chemicals and plastics which today rely on petroleum products for processing. Dwindling of oil supplies and the need to reduce dependence on oil have prompted scientists to develop ways of substituting corn products.

This may require expansion at existing facilities and building of new plants to handle the production needs. With most corn processing plants primarily located in close proximity to the growing fields, this will be a market expansion both domestically to service the American produced corn as well as globally to support foreign processing needs.

These guidelines reference the latest seal and sealing system technologies that can successfully seal corn milling equipment. Flowserve sealing systems can provide significant savings including:

1. Reduced product losses
2. Lower power requirements
3. Reduced downtime by increasing mean time between planned maintenance (MTBPM)

4. Reduced maintenance costs resulting from the mechanical seal's:

- Ease of installation
- Long, trouble-free life
- Design repairability
- Low cost repair program
- Elimination of adjustment costs associated with packing applications

As an introduction to the corn processing industry, the various steps involved with corn milling are discussed. This discussion is followed by a selection guide that is designed to provide recommendations for seal type, materials of construction, and environmental controls to obtain the maximum benefit from using the latest technologies. Alternate designs are shown to allow a cost effective selection based on plant practices, availability of an external flush, difficult equipment tear down, and the economics of the application.

These seal and sealing system recommendations should be considered as guidelines denoting the preferred designs for the applications listed. In many cases, other Flowserve seals may be suitable depending on application requirements and customer preferences. If you are unsure of the suitability of a recommendation for a particular application, contact your Flowserve Representative for assistance.

Featured Seal Descriptions

The seal designs and information shown represent standard configurations of popular seals that may typically be used in the Corn Processing Industry. Other configurations, sizes, and products are available to ensure adequate equipment operation. Consult your Flowserve representative for assistance.

ISC Series Seals

ISC Series Seals are designed to fit either standard bore or enlarged bore equipment in both inch and metric sizes ranging from 1.000" to 2.750" (25 mm to 70 mm). All seals include throttle bushings, vent and drain ports, flush or barrier fluid ports, and circulating devices on dual seals as standard features. Standard metallurgies include Alloy C-276 metal bellows or springs with 316 Stainless Steel for other metal components. Standard secondary seals are fluoroelastomer. Other materials are available upon request. See FSD115 for more information.

⁵ The World of Corn 2003, National Corn Growers Association, <http://www.ncga.com>

ISC1PX

A single inside mounted cartridge pusher seal

Seal Faces: Carbon, Direct Sintered Silicon Carbide, or Tungsten Carbide vs. Direct Sintered Silicon Carbide

Maximum Pressure: 300 psi (20 bar)

Temperature: -40° F to 400° F (-40° C to 204° C)

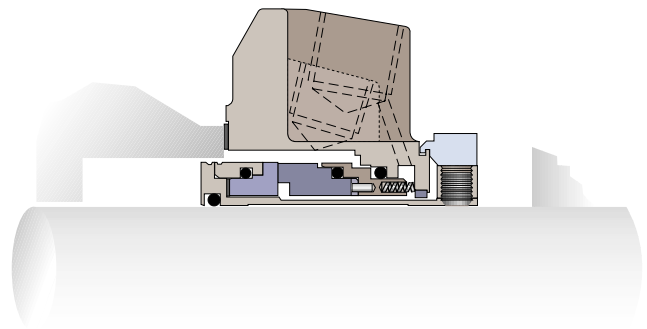

ISC1PX

ISC1BX

A single inside mounted cartridge metal bellows seal

Seal Faces: Carbon, Direct Sintered Silicon Carbide, or Tungsten Carbide vs. Direct Sintered Silicon Carbide

Maximum Pressure: 200 psi (14 bar)

Temperature: -40° F to 400° F (-40° C to 204° C)

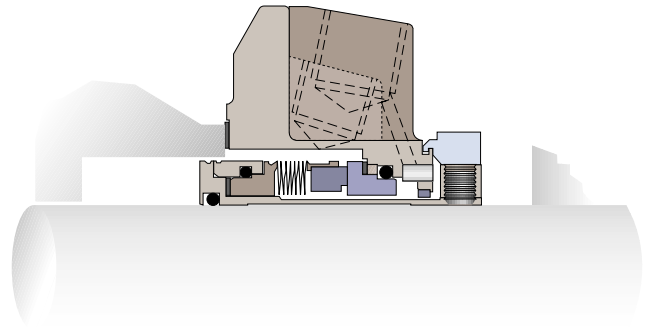

ISC1BX

ISC2PP

A dual cartridge pusher seal with pressurized barrier or non-pressurized buffer

Seal Faces: Carbon, Direct Sintered Silicon Carbide, or Tungsten Carbide vs. Direct Sintered Silicon Carbide

Maximum Process Pressure:

250 psi (17 bar) with pressurized barrier

300 psi (20 bar) with non-pressurized buffer

Maximum Barrier Pressure: 300 psi (20 bar)

Temperature: -40° F to 400° F (-40° C to 204° C)

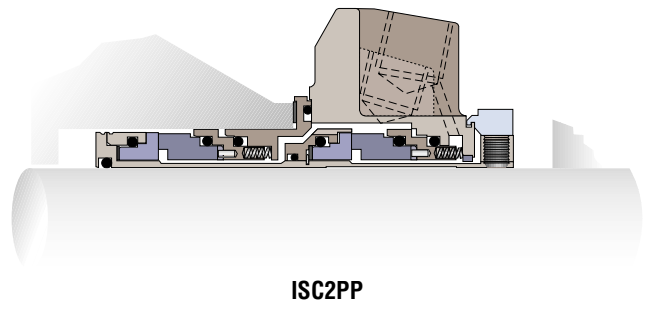

ISC2PP

ISC2BB

A dual cartridge metal bellows seal with pressurized barrier or non-pressurized buffer

Seal Faces: Carbon, Direct Sintered Silicon Carbide, or Tungsten Carbide vs. Direct Sintered Silicon Carbide

Maximum Process Pressure:

150 psi (10 bar) with pressurized barrier

200 psi (14 bar) with non-pressurized buffer

Maximum Barrier Pressure: 200 psi (14 bar)

Temperature: -40° F to 400° F (-40° C to 204° C)

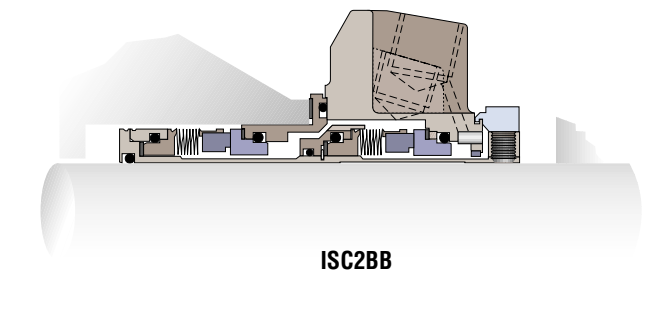

ISC2BB

ISC1EX

A single inside mounted cartridge elastomer bellows seal

Seal Faces: Carbon or Graphitized Sintered Silicon Carbide vs. Direct Sintered Silicon Carbide or Tungsten Carbide

Maximum Pressure: 150 psi (10 bar)

Temperature: -40° F to 400° F (-40° C to 204° C)

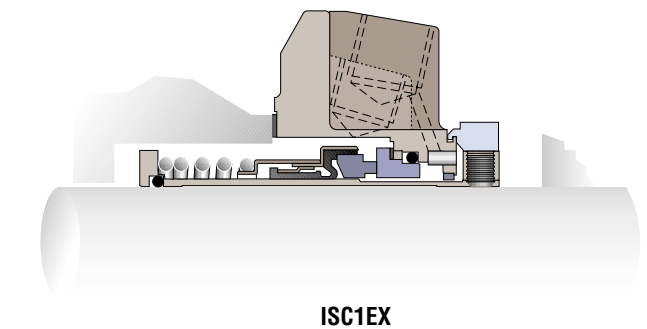

ISC1EX

CPM Series Seals

CPM Series Seals are designed to operate under corn process operating conditions, from handling the solids found in corn steep to the light specific gravity applications found in ethanol refining. Based on 80 Series technology, the CPM seals are targeted to fit either standard bore or enlarged bore equipment in sizes ranging from 1.375" to 4.750" (35 mm to 120 mm). Standard metallurgies include

CPMPX

A single inside mounted cartridge pusher seal
Seal Faces: Carbon, Tungsten Carbide, Direct Sintered Silicon Carbide, or Graphitized Sintered Silicon Carbide vs. Direct Sintered Silicon Carbide
Maximum Pressure: 300 psi (20 bar)
Temperature: -40° F to 400° F (-40° C to 204° C)

CPM PP

A dual cartridge pusher seal with pressurized barrier or non-pressurized buffer
Seal Faces: Carbon, Tungsten Carbide, Direct Sintered Silicon Carbide, or Graphitized Sintered Silicon Carbide vs. Direct Sintered Silicon Carbide
Maximum Process Pressure:
275 psi (19 bar) with pressurized barrier
300 psi (20 bar) with non-pressurized buffer
Maximum Barrier Pressure: 300 psi (20 bar)
Temperature: -40° F to 400° F (-40° C to 204° C)

SLM Series Seals

SLM Series seals are designed to fit enlarged bore equipment in sizes ranging from 2.000" to 9.250" (51 mm to 235 mm). Springs are isolated outside the product and centroid loaded rotors help maintain zero net deflection during pressure and temperature changes. Smooth, contoured part geometries reduce erosion and minimize abrasive turbulence. Clamp collar drives maximize axial holding forces without galling sleeves. Up to 40% solids by weight with a Mohs scale particle hardness at 9 or below

SLM-6000

A single inside mounted cartridge pusher seal with no external lubrication
Seal Faces: Direct Sintered Silicon Carbide vs. Direct Sintered Silicon Carbide is standard. Tungsten Carbide and Reaction Bonded Silicon Carbide are optional.
Maximum Pressure: 250 psi (17 bar)
Temperature: 0° F to 175° F (-18° C to 79° C)

Alloy C-276 springs with 316 Stainless Steel for other metal components. Single seals have an optional bushing available for a quench system if required. Standard secondary seals are TFE-Propylene (Aflas®). Other materials are available upon request. See FSD199 for more information.

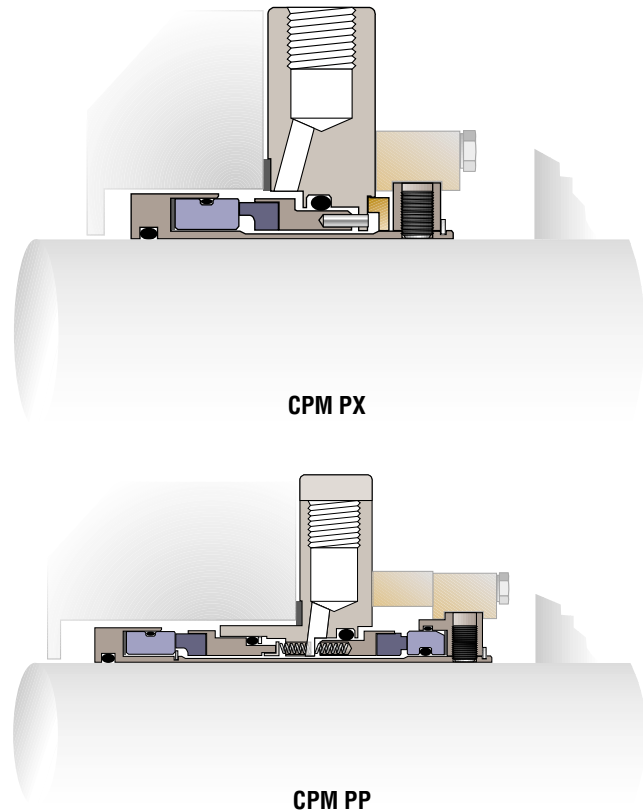

can be handled. Alloy C-276 springs are standard. CD4MCuN (Duplex 255) is standard for wetted metal components with Alloy C-276 and High-Chrome Iron optional. 316 Stainless Steel is standard for non-wetted metal components on dual seals. Fluoroelastomer, EPDM, and TFE-Propylene are standard secondary seals. Other materials are available upon request. See FSD166 for more information.

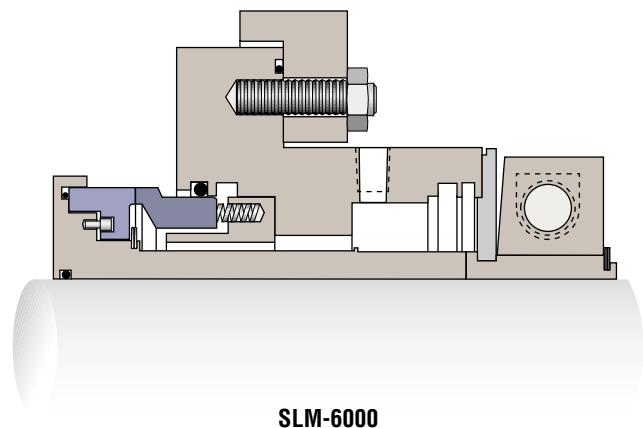

SLM-6000 QCD/SLM-6000 SLD

A single inside mounted cartridge pusher seal with either a water quench (QCD) or a synthetic lubricant (SLD) for dry equipment operation.

Seal Faces: Direct Sintered Silicon Carbide vs. Direct Sintered Silicon Carbide is standard. Tungsten Carbide and Reaction Bonded Silicon Carbide are optional.

Maximum Pressure: 250 psi (17 bar)

Temperature: 32° F to 275° F (0° C to 135° C) with QCD (water quench),
0° F to 175° F (-18° C to 79° C) with SLD (lube quench)

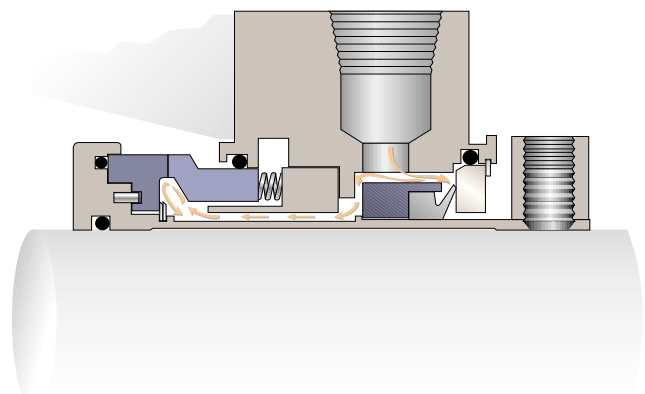

SLM-6000 QCD / SLM-6000 SLD

SLM-6200

A dual cartridge pusher seal with pressurized barrier to isolate the process liquid

Seal Faces: Direct Sintered Silicon Carbide vs. Direct Sintered Silicon Carbide is standard. Reaction Bonded Silicon Carbide is optional. Tungsten Carbide is optional except for inner seal rotors.

Maximum Pressure: 300 psi (20 bar) process with 350 psi (24 bar) barrier through 7.375" (187 mm) and 250 psi (17 bar) process with 300 psi (20 bar) barrier for larger sizes

Temperature: 0° F to 300° F (-18° C to 150° C) for process fluid
175° F (79° C) maximum for barrier

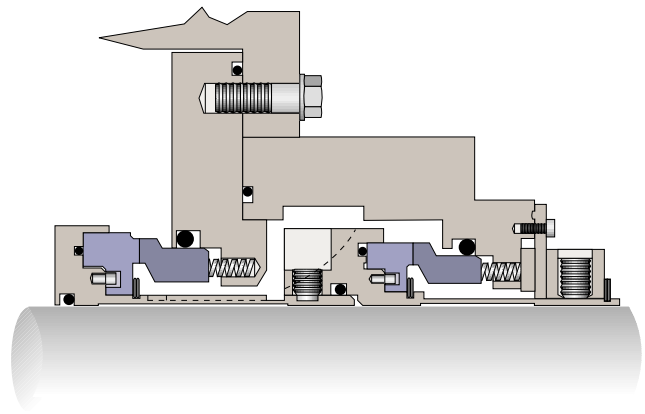

SLM-6200

PSS II Seals

PSS II seals are designed to fit standard bore equipment in inch and metric sizes from 1.500" to 6.000" (38 mm to 152 mm). This seal is radially split with built-in axial and radial setting clips to simplify and ensure accurate installation. Springs and pins are isolated from the product. Wear indicator pins allow visual check of the seal setting to determine wear rates and estimate run times. Flexible stator design and radial clearances allow operation under a

total indicated run-out of up to 0.060" (1.5 mm). An installation kit including tools and extra hardware is provided. Standard repair kits are available. Alloy C-276 springs and 316 Stainless Steel for other metal components are standard. Fluoroelastomer, EPDM, and TFE-Propylene are standard secondary seals. Other materials are available upon request. See FSD125 for more information.

PSS II

A single semi-cartridge split pusher seal with flush capabilities mounted outside the seal chamber

Seal Faces: Carbon vs. Aluminum Oxide or Direct Sintered Silicon Carbide and Direct Sintered Silicon Carbide vs Direct Sintered Silicon Carbide or Reaction Bonded Silicon Carbide

Maximum Pressure: 150 psi (10 bar)

Temperature: 0° F to 250° F (-18° C to 121° C)

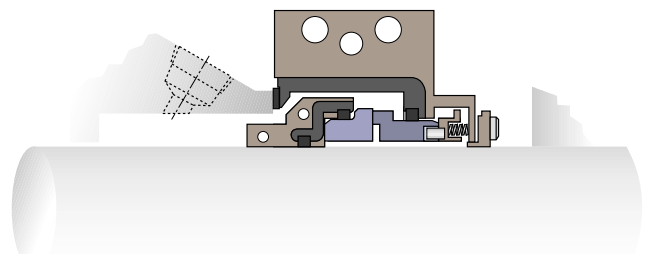

PSSII

MSS Seals

MSS seals are designed to fit mixers, agitators, and other containment vessels where large shaft run-out of up to 0.150" (3.8 mm) might be expected. This wet or dry running seal is radially split and covers shaft sizes from 1.000" to 12.000" (25 mm to 305 mm). Springs and pins are isolated

from the product. 316 Stainless Steel is standard for metal components and Fluoroelastomer is standard for secondary seals. Other materials are available upon request. See FSD162 for more information.

MSS

A single outside mounted split pusher seal

Seal Faces: Carbon vs. Aluminum Oxide or
Carbon vs. Tungsten Carbide

Maximum Pressure: 75 psi (5 bar) dry
100 psi (7 bar) wet

Temperature: 0° F to 250° F (-18° C to 121° C)

Maximum Speed: 350 rpm dry / 1,750 rpm wet

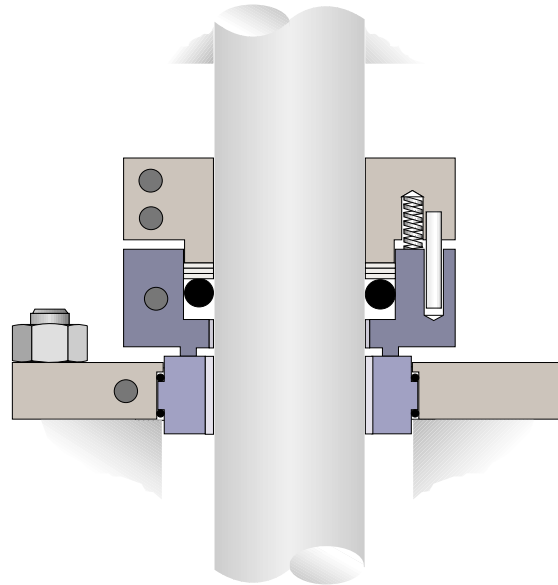

MSS

QB Series Seals

QB Series seals are designed to fit enlarged bore equipment in inch and metric sizes from 0.500" to 5.500" (13 mm to 140 mm). This seal can address high pressure and high temperature services such as boiler feed water. A QB Lube option is available for hot water applications where no cooling water can be supplied. A high balance QBQ version provides lower emissions and targets hazardous

products. Standard metallurgy is Alloy C-276 for springs and 316 Stainless Steel, Alloy C-276, or Alloy 20 for other metal components. Fluoroelastomer is standard for secondary seals with Nitrile, Perfluoroelastomer, EPDM or TFE-Propylene optional. Other materials are available upon request. See FSD152 for more information.

QB

A single inside mounted cartridge pusher seal

Seal Faces: Carbon vs. Reaction Bonded Silicon
Carbide, Direct Sintered Silicon
Carbide, or Tungsten Carbide

Maximum Pressure: 750 psi (52 bar)

Temperature: -40° F to 400° F (-40° C to 204° C)

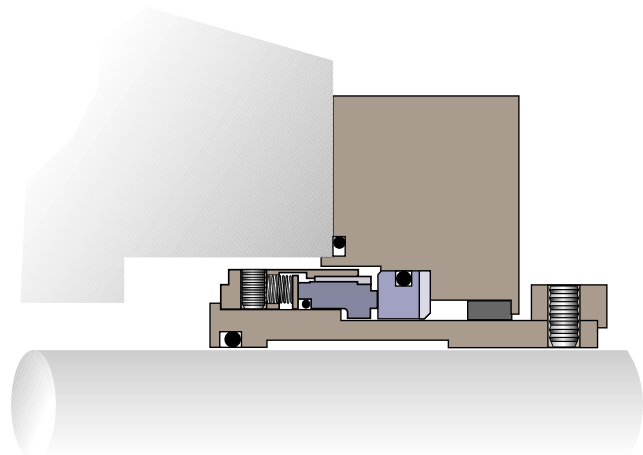

QB

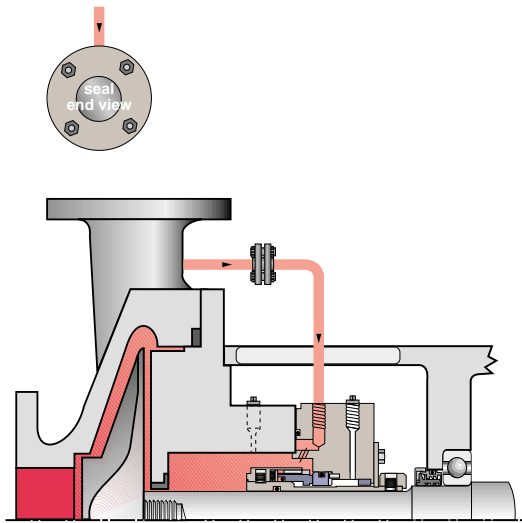

Recirculation from Pump Case through Orifice to Seal
API Plan 11 (ANSI Plan 7311)

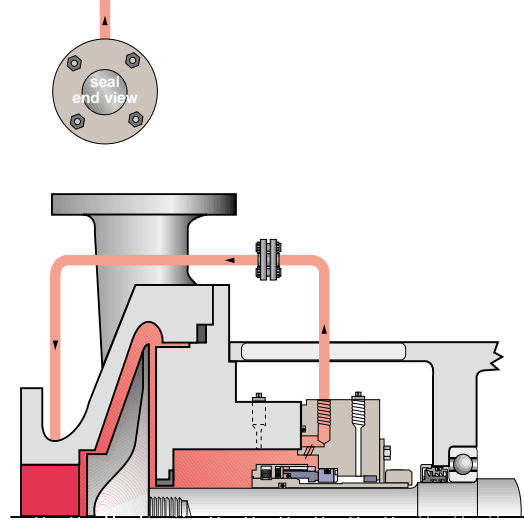

Recirculation to Pump Suction on Vertical Pumps
API Plan 13 (ANSI Plan 7313)

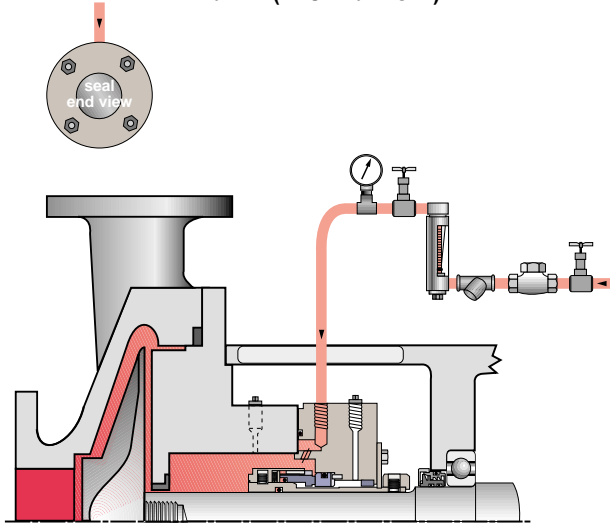

Injection of Clean Fluid from External Source
API Plan 32 (ANSI Plan 7332)

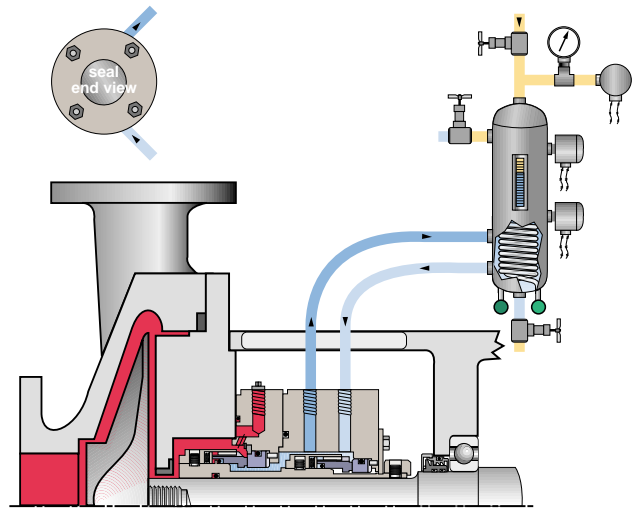

External Fluid Reservoir Pressurized; Forced Circulation
API Plan 53 (ANSI Plan 7353)

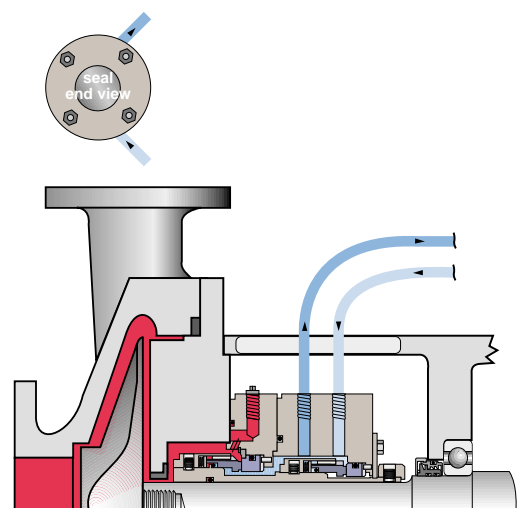

Circulation of Clean Fluid from an External System
API Plan 54 (ANSI Plan 7354)

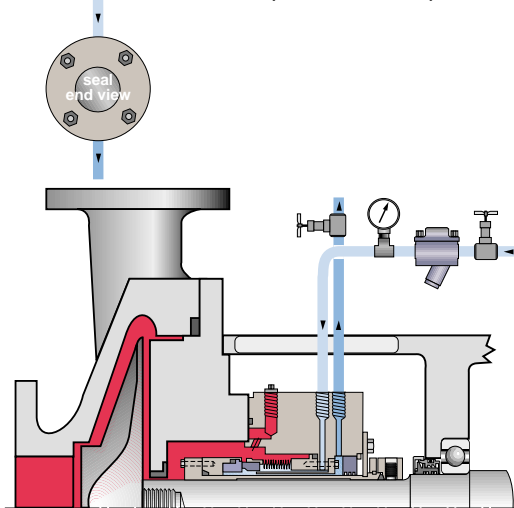

Injection of Steam or Water on Atmospheric Side of Seal
API Plan 62 (ANSI Plan 7362)

Corn Wet Milling Process Summary

Corn wet milling is a complex process developed to transform corn into many other useful products. The primary resource from corn is the kernel. Wet milling separates the kernels into the four main components of starch, germ, protein, and fiber.³

The type of corn used in wet milling affects the amount of yield produced and the economics of the process. Corn developers continually evaluate new varieties of corn to optimize characteristics for use in this process. The best kernel types are those that are large and softer in texture to make it easier for the process to separate the components.

The corn kernel is made up of four main parts as shown in Figure 3.⁶ The kernel coating or pericarp is an outer layer of fiber that provides protection from microorganisms and insects.⁵ During processing, it becomes part of the fibrous chaff that is used in the production of animal feed.

Corn Kernel Components

Figure 3

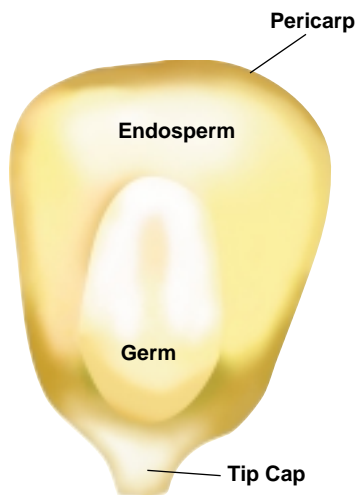

The germ or embryo is in the center and is the living portion of the kernel containing a mini plant with roots and leaves. It is the oil rich portion with about 25% of its weight being oil. The tip cap is at the base where the kernel was attached to the cob and was the pathway to obtain food and water while growing. The endosperm is the remaining portion, typically about 82% of the kernels dry weight. It contains starch, which is a complex carbohydrate, and gluten, which is a protein.⁵

Yellow dent corn, also referred to as field corn, is the type primarily used. Other types such as waxy or high amylose corn might be used when starches must be produced for specific needs. High oil corn might be used when corn oil will be the principle product.² Yellow dent corn gets its name from both its color and the inward dent on each side of the kernel. From one bushel of yellow dent corn, the typical yield is about 31.5 pounds of starch, 13.5 pounds of gluten feed, 2.5 pounds of gluten meal, and 1.6 pounds of corn oil.²

For comparison, yellow dent corn is much different from the sweet corn we eat as a vegetable. Sweet corn has a much thinner pericarp making it easy to eat. It is also high in sugar giving it a sweet taste. The thicker pericarp of yellow dent corn is much harder and does not soften up so it can be easily eaten in natural form, even after hours of cooking.⁷

The corn used by wet milling facilities is removed from the cob during field harvesting. In the United States, it is classified by U.S. Grading Standards that were established by the U.S. Department of Agriculture (USDA). These standards define the amounts of damaged kernels, broken corn, and foreign material that is allowed in the raw product.⁸

Corn wet milling has existed for more than 150 years and has evolved and been perfected over that time into the process used today.³ Wet milling is primarily a closed process with equipment, reactors, and tanks being enclosed wherever possible to prevent the entrance of foreign material. Ducts and pipes are located to ensure that any drips, condensate, dust, or debris does not contaminate the products being made. Plant structures and processing equipment are well maintained and properly sanitized for each step of the process. Continuous in-process and finished product analyses are conducted to ensure that the ingredients used in this process do not add harmful chemicals, pathogens, and other dangerous foreign materials to food products.⁸

Five basic steps are common to the wet milling process. These steps, shown in Figure 4, include:

1. Inspection and Cleaning
2. Steeping
3. Germ Separation
4. Fine Grinding and Screening
5. Starch Separation

The starch produced can be converted to syrups or it can be fermented to produce other products.

² Frequently Asked Questions, Corn Refiners Association, <http://www.corn.org/web/faq.htm>, (Reproduced with permission of Corn Refiners Association, Inc.)

³ The Process (step-by-step), Corn Refiners Association, <http://www.corn.org/web/process.htm>, (Reproduced with permission of Corn Refiners Association, Inc.)

⁵ The World of Corn 2003, National Corn Growers Association, <http://www.ncga.com>

⁶ Special Report No. 48, How a Corn Plant Develops, Iowa State University of Science & Technology, <http://maize.agron.iastate.edu/corngrows.html>

⁷ Yellow Dent Corn, Walton Feed, <http://waltonfeed.com/self/corn.html>

⁸ Corn Annual 2003, Corn Refiners Association, <http://www.corn.org>, (Reproduced with permission of Corn Refiners Association, Inc.)

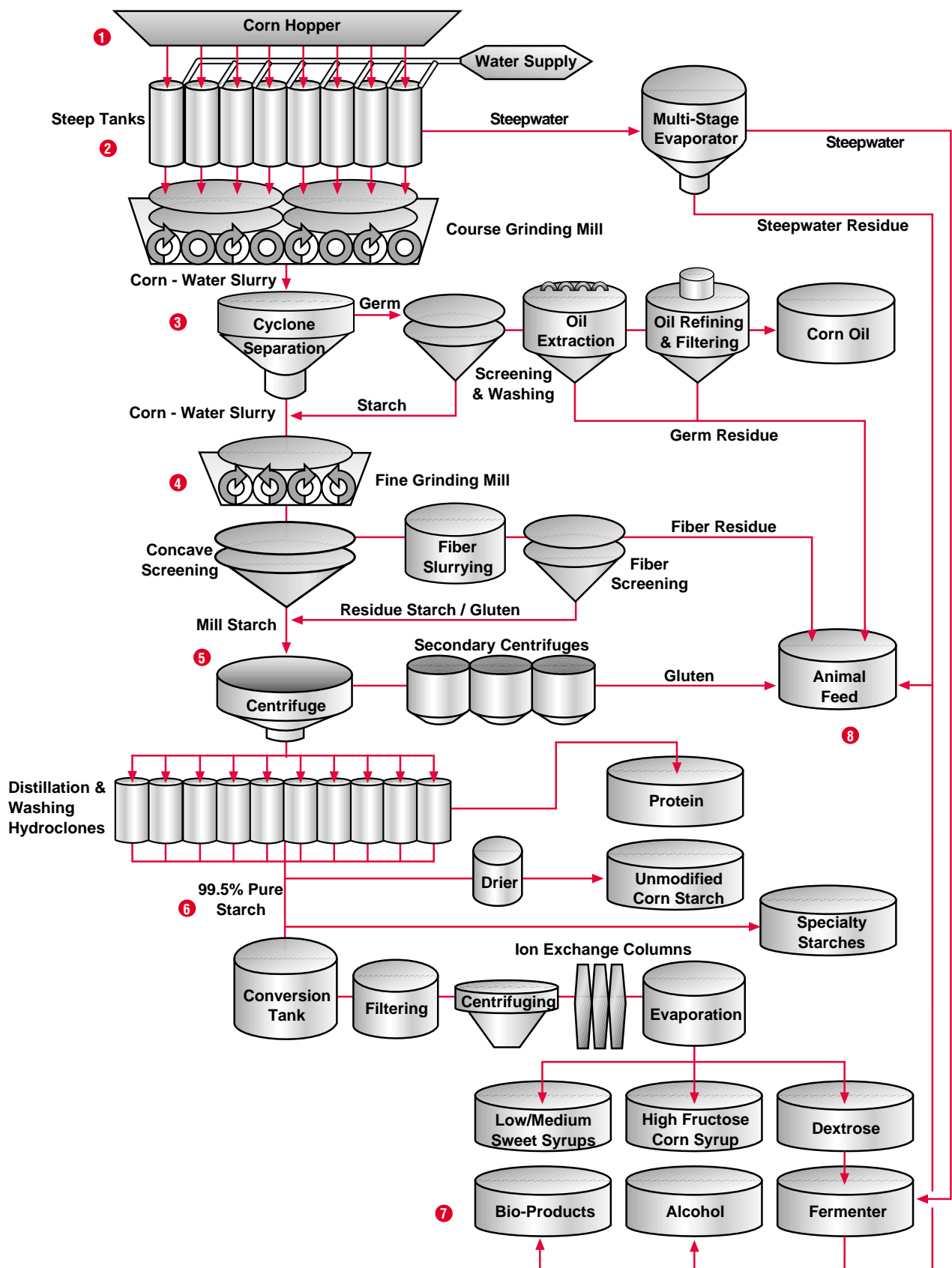

Inspection and Cleaning³ ①

The harvested corn that arrives in bulk at a milling facility usually contains dirt, cob residue, chaff, and other foreign materials. Before it goes into the milling process, it must be thoroughly inspected to identify the contaminants and ensure that the cleaning will remove all unwanted residue.

The cleaning process typically uses course wire mesh to sift out stones and other solid debris while ferrous magnets separate out metallic particles. This process is usually conducted twice to ensure that the corn is properly cleaned to meet the FDA's guidelines for particle size.

Steeping³ ②

The inspected and cleaned corn is transported from storage silos or hoppers and loaded into large stainless steel steep tanks. A typical plant may contain eight to ten steep tanks, some even more. These tanks are normally sized to accommodate about 3,000 bushels of corn where it is mixed with water. Each steep tank has a conical shaped bottom with screens and is fitted with its own pump to recirculate the water during steeping.

The corn is soaked at a temperature between 120° F and 127° F (49° C and 53° C) for a period of from 30 to 40 hours. During this soaking, the corn kernel moisture content increases from its normal 15-16% to about 45%. This softens the kernels and causes them to swell to more than twice their normal size.

Steeping is actually a controlled fermentation process where about 0.1% to 0.2% sulfur dioxide (SO₂) is added to control the amount of bacterial growth and increase the rate of water absorption into the corn. While the steepwater's mild acidity allows the gluten bonds within the kernel to loosen and begin releasing starch into the corn-water slurry, it can pit tungsten carbide seal faces and swell most elastomer materials typically used in pump seals except Aflas[®].

Over the years this process has evolved, much has been done to weigh various factors when optimizing the steeping time and temperature. The typical steeping time in itself is not optimal since recoverable nutrients are leached from the kernel. Shortening the cycle time reduces the efficiency of starch separation. Longer time periods yield starch with a lower viscosity. Both results are less⁹ desirable than what the existing process provides.

The steeping temperature also affects the process efficiency. Lower temperatures lengthen the process to achieve the same productivity. Higher temperatures can reduce the steeping time since it increases protein dispersion. However, a higher temperature provides excessive nutrient leaching and produces less recoverable starch.

When the corn kernels are sufficiently broken down so they can be adequately milled, sluce pumps transport the corn and steepwater from the steep tanks over dewatering screens to drain the lighter steepwater, typically containing between 5% and 7% solids, from the steep tanks. The steepwater is pumped to an evaporator where it is condensed to draw off important nutrients. Two types of evaporators, a falling film or a multi-effect, can be used depending on the refining process.

The nutrients pulled from the evaporator are used in the production of animal feed and in subsequent fermentation processes to manufacture other products. Most of the acids generated during steeping are volatile and evaporate with the water. Unusable condensate from the evaporator usually contains Volatile Organic Chemicals (VOC's) that must be treated before being discarded.

The corn and remaining water from the steep tanks or corn-water slurry is pumped to a course grinding mill where the germ is broken free from the rest of the kernel. Here, studded grinding drums, one rotating and one stationary, are used to open the kernel hulls to separate starch without damaging the germ. The size and distribution of the studs as well as the distance between the drums control how fine the corn is ground. A second grinder is used to open any unbroken kernels.

³ The Process (step-by-step), Corn Refiners Association, <http://www.corn.org/web/process.htm>, (Reproduced with permission of Corn Refiners Association, Inc.)

⁹ S. Gunasekaran & D. Farkas, High-Pressure Hydration of Corn, American Society of Agricultural Engineers Paper No. 87-6564, 1988

® Registered Trademark of Asahi Glass Co., Ltd.

Germ Separation³ ③

The ground corn slurry is pumped into cyclone separators to spin the lower density germ out of the slurry. About 85% of the oil is contained in the germ. Once separated, the germ is pumped over screens where it is washed several times to remove any residual starch and fiber.

Mechanical processes along with a hexane solvent wash are used to extract the oil from the germ. This initially yields a mixture of about 90% hexane and 10% oil. This fluid mixture is pumped back through the process to yield a more refined mixture of about 50% hexane and 50% oil. This extracted fluid is further processed until a mixture of about 20% hexane and 80% oil is obtained.

The hexane and oil mixture is then filtered and refined by boiling off the hexane in a cooker to produce 100% corn oil. The corn oil is stored in a holding tank until the market is ready to accept it for use. Pumps continually agitate the corn oil to help keep it well mixed. The remaining residue from the germ processing is collected and pumped on for use in animal feed production.

Fine Grinding and Screening³ ④

The corn water slurry that is recovered from the cyclone separation, washing, and screening of the germ is pumped to a fine grinding mill so the slurry can be ground more thoroughly. This fine grinding is performed in an impact grinder.

This process is similar to course grinding except that both drums are rotated with movement in opposite directions. Fine grinding releases starch, gluten, and fiber from the remaining kernel chaff.

This mixture is pumped over a series of concave screens where the fiber is filtered out. The remaining

filtrate is about 30% to 40% starch. The fiber removed is slurried and pumped through a series of course and fine screens, typically in 7 or more stages.

The wash water is pumped in a counterflow manner to remove any remaining starch and gluten for pumping to the starch recovery process. The fiber collected is pumped through dewatering cycles to increase the solids content to about 40% before it is pumped on for use in animal feed.

Starch Separation³ ⑤

The starch and gluten stock, or mill starch, that is recovered from the grinding and screening processes are pumped to a centrifuge where the gluten, having a lower density than the starch, is readily spun out. The gluten is dewatered using secondary centrifuges and filtered to produce corn gluten at about 90% solids for use in animal feed.

The remaining starch is pumped to a bank of hydroclones. Usually, there are ten hydroclones in a bank where water is pumped through a series of counterflow washes to dilute and redilute the starch to remove any remaining protein.

The water is deionized or purified to prevent any off flavor taste in syrups that will be produced. Each hydroclone contains a dedicated pump to transfer the high quality slurry at approximately 99.5% purity for further processing.

Syrup Conversion³ ⑥

A portion of the 99.5% pure starch is dried and sold as unmodified corn starch. Another portion is modified to become specialty starches.

However, a majority of the starch is processed into syrups and dextrose through syrup conversion. Acids, typically a hydrochloric acid solution, are used

³ The Process (step-by-step), Corn Refiners Association, <http://www.corn.org/web/process.htm>, (Reproduced with permission of Corn Refiners Association, Inc.)

to liquefy the starch suspended in water to convert it to a low dextrose solution. Enzymes may be added to convert the sugar that is stored in the corn to starch.

Pumping it through various processes that typically include filtering, centrifuging, and ion exchange columns refines the starch. Centrifuging removes any remaining medium to large particles. Filtering is a micro screening process that removes small particles to make the syrup food grade. The ion exchange or carbon columns purify the syrups and remove any remaining color. At the end, all excess water is evaporated.

This process allows the refiner to control the acid or enzyme activity to produce the end composition desired. Some syrups provide a low to medium sweetness by stopping the acid/enzyme action early in the process. When the acid/enzyme activity is allowed to work a longer period of time, the syrup becomes a pure dextrose, an ingredient used in industries such as pharmaceutical and alcohol production.

An intermediate acid/enzyme activity produces high fructose corn syrups. High fructose corn syrups are typically mild sweeteners used in canned fruit, condiments, and other processed foods where the natural food flavors should not be hidden. They can provide additional sweetening for ice creams, soft drinks, and frozen foods.

High fructose corn syrups can also provide a higher level of sweetening for natural and light foods where only a minimum of additional sweetening is necessary. High fructose corn syrup provides the greatest level of sweetening which, when combined with sugar, is used in cereals, instant beverages, and dry food mixes.

The syrup making processes are more proprietary to each refiner. The types of processes used and the resulting products also vary per refiner. Some do not get involved with processing starch into syrups, some concentrate on the production of corn syrup, and others process a variety of products for commercial and industrial use.

Fermentation³ 7

Many refiners pump dextrose to a fermenting facility for conversion to alcohol and bio-products. Dextrose is the best sugar form for fermentation. Conversion to alcohol is achieved by adding yeast and distilling the resulting broth or beer. The yeast or bacterial additions transform the dextrose into amino acids and other products through membrane separation.

This process takes about 40 to 50 hours in a cool environment to facilitate the yeast fermentation. Distillation dewateres the alcohol to provide a high quality, 190 to 200 proof, product. Blending the alcohol with a 5% denaturant such as gasoline makes it non-food grade and not subject to beverage grade alcohol taxes so it can be economically used as ethanol for fuel blending. The fermentation process also produces carbon dioxide (CO₂) that is recovered and sold to beverage manufacturers to produce the fizz we expect in many soft drinks. The nutrients recovered are pumped for use in animal feed production.¹⁰

Animal Feed Production³ 8

The condensed steepwater, germ, fiber, gluten, and fermentation residue may be pumped all or in part to an animal feed facility. Each of these residues contains a high amount of protein and energy nutrients that are good for animal feeds. Each residue's slurry is pumped through driers and evaporators to remove as much of the remaining water as possible. The drying processes thicken each slurry until they have about 50% solids.

Additional driers are used to further process the germ, fiber, and gluten residue to produce varying qualities of feed cakes and pellets using as much of these bi-products as necessary. The type of driers applied greatly depends on the color and consistency expected for the final feed product.

³ The Process (step-by-step), Corn Refiners Association, <http://www.corn.org/web/process.htm>, (Reproduced with permission of Corn Refiners Association, Inc.)

¹⁰ Ethanol Production Process, Renewable Fuels Association, http://www.ethanolrfa.org/prod_process.html

Seal Application Guidelines

Each step in the corn wet milling process requires the movement of liquids and slurries that utilize a large number of pumps, agitators, refiners, and other rotating equipment. There may be as many as 30 to 40 pieces of sealed equipment for these activities.

Some plants may not concentrate on all portions of the process and similar services may be performed in different steps depending on the refining plant involved. Besides the basic process activities, many auxiliary applications are performed which typically need to be sealed. These activities are equally important to the process and may include water circulation in many steps, corn syrup and corn oil transport to trucks and railway cars, caustic solution washes to clean lines and filters, and sulfuric acid additions for sanitation and to speed chemical reactions.

Wastewater in varying forms must also be dealt with. Lime slurries and soda ash may be added to control the pH levels of the wastewater. Sump pumps may be used to move wastewater from the various points of creation to its disposal.

The seal recommendations shown in Figure 5 cover the major services that may be encountered when processing corn in this manner. Temperature ranges are approximate and will depend on the refiner's process. They provide sealing options that may depend on the equipment involved and should be considered as generally preferred designs. Material codes for these designs are defined in Figure 6. In many cases, other Flowserve seals, seal arrangements, piping plans, and materials of construction may be equally or more suitable depending on the application and the customer preferences. For services not identified or if you are unsure of the suitability of a recommendation for a particular application, contact your Flowserve representative.

Seal Application Recommendations

Figure 5

Process Service	Temperature Range	Bellows Seal Type	Material Code	Pusher Seal Type	Material Code ^(A)	API Flush Plan ^(B)
Water - Clean	59-86° F (15-30° C)	ISC1BX	CSCBX----ECXV -	ISC1PX	CSCPX----ECXV-	11, 13, or 32
				ISC1EX	CSCEX----ECXV-	11, 13, or 32
				CPM PX	CPMPX----ECXV-	11, 13, or 32
				PSSII	ER7EFVV	11, 13, or 32
Water - Demineralized	59-86° F (15-30° C)	ISC1BX	CSCBX----ECXV-	ISC1PX	CSCPX----ECXV-	11, 13, or 32
				ISC1EX	CSCEX----ECXV-	11, 13, or 32
				CPM PX	CPMPX----ECXV-	11, 13, or 32
				PSSII	ER7EFVV	11, 13, or 32
Water - River or Lake	59-86° F (15-30° C)	ISC1BX	CSCBX----ECXV-	ISC1PX	CSCPX----EUXV-	11, 13, or 32
				ISC1EX	CSCEX----EUXV-	11, 13, or 32
				CPM PX	CPMPX----EUXV-	11, 13, or 32
				SLM-6000	B(2/V)2BPVV	02 (Dead-End)
Light (20%-30% Solids) Steepwater - Recirculation	120-127° F (49-53° C)	None	None	ISC2PP	CSCPX----EUCV-	53 or 54
				CPM PP	CPMPX----EUCV-	53 or 54
Medium (30%-40% Solids) Steepwater - Slewce Pumps	120-127° F (49-53° C)	None	None	ISC2PP	CSCPX----EUCV-	53 or 54
				CPM PP	CPMPX----EUCV-	53 or 54
Heavy (40%-50% Solids) Steepwater	120-127° F (49-53° C)	None	None	SLM-6200	(B/E)2(U/2)(B/E)FVV	53 or 54
				ISC2PP	CSCPX----EUCV-	53 or 54
				CPM PP	CPMPX----EUCV-	53 or 54
				SLM-6200	(B/E)2(U/2)(B/E)FVV	53 or 54
Steep Liquor Transfer	120-127° F (49-53° C)	None	None	ISC2PP	CSCPX----EUCV-	53 or 54
				CPM PP	CPMPX----EUCV-	53 or 54
				SLM-6200	(B/E)2(U/2)(B/E)FVV	53 or 54
				ISC2PP	CSCPX----EUCV-	53 or 54

Seal Application Recommendations continued

Process Service	Temperature Range	Bellows Seal Type	Material Code	Pusher Seal Type	Material Code A	API Flush Plan B
Corn Mash Dry Mill Slurry (15%-30% Solids)	136-176° F (58-80° C)	None	None	ISC2PP CPM PP	CSCPP----EUCV- CPMPP----EUCV-	53 or 54 53 or 54
Germ Separation	86-104° F (30-40° C)	None	None	ISC2PP CPM PP	CSCPP----EUCV- CPMPP----EUCV-	53 or 54 53 or 54
Germ Hexane Washing	86-104° F (30-40° C)	None	None	ISC1PX ISC1EX CPM PX	CSCPX----ECXV- CSCEX----ECXV- CPMPX----ECXV-	11, 13, or 32 11, 13, or 32 11, 13, or 32
Steep Liquor Corn Oil Extraction	140-176° F (60-80° C)	ISC1BX	CSCBX----EUXV-	ISC1PX CPM PX	CSCPX----EUXV- CPMPX----EUXV-	11, 13, or 32 11, 13, or 32
Steep Liquor Corn Oil Refining	140-176° F (60-80° C)	None	None	ISC2PP CPM PP	CSCPP----EUCV- CPMPP----EUCV-	53 or 54 53 or 54
Corn Oil Agitation	140-176° F (60-80° C)	ISC1BX	CSCBX----ECXV-	ISC1PX ISC1EX CPM PX	CSCPX----ECXV- CSCEX----ECXV- CPMPX----ECXV-	11, 13, or 32 11, 13, or 32 11, 13, or 32
Corn Oil Loading	68-122° F (20-50° C)	ISC1BX	CSCBX----ECXV-	ISC1PX ISC1EX CPM PX PSS II	CSCPX----ECXV- CSCEX----ECXV- CPMPX----ECXV- ER7EFVV	11, 13, or 32 11, 13, or 32 11, 13, or 32 11, 13, or 32
Fiber Separation	68-113° F (20-45° C)	None	None	ISC2PP CPM PP	CSCPP----EUCV- CPMPP----EUCV-	53 or 54 53 or 54
Fiber Washing	68-113° F (20-45° C)	ISC1BX	CSCBX----EUXV-	ISC1PX ISC1EX CPM PX	CSCPX----EUXV- CSCEX----EUXV- CPMPX----EUXV-	11, 13, or 32 11, 13, or 32 11, 13, or 32
Gluten Transfer	68-140° F (20-60° C)	None	None	ISC2PP CPM PP	CSCPP----EUCV- CPMPP----EUCV-	53 or 54 53 or 54
Gluten Dry Milling	122-140° F (50-60° C)	ISC1BX	CSCBX----EUXV-	ISC1PX ISC1EX CPM PX	CSCPX----EUXV- CSCEX----EUXV- CPMPX----EUXV-	11, 13, or 32 11, 13, or 32 11, 13, or 32
Dry Milling Liquor	140-176° F (60-80° C)	None	None	ISC2PP CPM PP	CSCPP----EUCV- CPMPP----EUCV-	53 or 54 53 or 54
Gluten Dewatering	86-104° F (30-40° C)	ISC1BX	CSCBX----EUXV-	ISC1PX ISC1EX CPM PX	CSCPX----EUXV- CSCEX----EUXV- CPMPX----EUXV-	11, 13, or 32 11, 13, or 32 11, 13, or 32
Gluten Spray Bars	86-104° F (30-40° C)	ISC1BX	CSCBX----EUXV-	ISC1PX ISC1EX CPM PX	CSCPX----EUXV- CSCEX----EUXV- CPMPX----EUXV-	11, 13, or 32 11, 13, or 32 11, 13, or 32
Starch Transfer	86-140° F (30-60° C)	None	None	ISC2PP CPM PP	CSCPP----EUCV- CPMPP----EUCV-	53 or 54 53 or 54
Starch Hydroclone Washing	140-176° F (60-80° C)	None	None	ISC2PP CPM PP SLM-6000 QCD SLM-6000 SLD	CSCPP----EUCV- CPMPP----EUCV- B(U/V)(U/2)BQVV B(U/V)(U/2)BQVV	53 or 54 53 or 54 11 / 62 11 / 62
Syrup Transfer	32-176° F (0-80° C)	ISC2BB	CSCBB----ECCV-	ISC2PP CPM PP	CSCPP----ECCV- CPMPP----ECCV-	53 or 54 53 or 54
Syrup Carbon Filtration (Ion Exchange)	32-194° F (60-80° C)	ISC2BB	CSCBB----EUCV-	ISC2PP CPM PP	CSCPP----EUCV- CPMPP----EUCV-	53 or 54 53 or 54
Syrup Pumps	32-158° F (0-70° C)	ISC2BB	CSCBB----ECCV-	ISC2PP CPM PP	CSCPP----ECCV- CPMPP----ECCV-	53 or 54 53 or 54
Syrup Loading	59-86° F (15-30° C)	ISC2BB	CSCBB----ECCV-	ISC2PP CPM PP	CSCPX----ECCV- CPMPX----ECCV-	53 or 54 53 or 54
Process Condensate	32-250° F (0-121° C)	ISC1BX	CSCBX----ECXV-	ISC1PX CPM PX	CSCPX----ECXV- CPMPX----ECXV-	11, 13, or 32 11, 13, or 32
Process Condensate	>250° F (>121° C)	None	None	QB	5A4N	11
Cooling Tower	<95° F (<35° C)	None	None	ISC1PX CPM PX PSS II	CSCPX----ECXV- CPMPX----ECXV- ER7EFVV	13 13 13 or 32
Water Circulation	32-122° F (0-50° C)	ISC1BX	CSCBX----ECXV-	ISC1PX ISC1EX CPM PX PSS II	CSCPX----ECXV- CPCEX----ECXV- CPMPX----ECXV- ER7EFVV	11, 13, or 32 11, 13, or 32 11, 13, or 32 11, 13, or 32

Figure 5

Process Service	Temperature Range	Bellows Seal Type	Material Code	Pusher Seal Type	Material Code ^A	API Flush Plan ^B
Effluent / Wastewater	32-140° F (0-60° C)	None	None	ISC1PX	CSCPX----EUXV-	11
				CPM PX	CPMPX----EUXV-	11
				PSS II	ER7EFVV	11
Sump Pump	32-104° F (0-40° C)	ISC1BX	CSCBX----EUXV-	ISC1PX	CSCPX----EUXV-	11, 13, or 32
				ISC1EX	CSCEX----EUXV-	11, 13, or 32
				CPM PX	CPMPX----EUXV-	11, 13, or 32
Quench Tank Transfer	32-140° F (0-60° C)	ISC2BB	CSCBB----ETTV-	ISC2PP	CSCPP----ETTV-	53 or 54
				CPM PP	CPMPX----EUUV-	53 or 54
Mixer Tanks	32-122° F (0-50° C)	None	None	MSS	ER7EPVV	02 (Dead End)
Caustic Feed (1-20% Sodium Hydroxide)	68-140° F (20-60° C)	ISC1BX	CSCBX----ECXE-	PSS II	ER7EFVV	11, 13, or 32
				ISC1PX	CSCPX----ECXE-	11 / 62
				ISC2PP	CSCPP----EUCE-	53 or 54
Caustic Feed (21-50% Sodium Hydroxide)	68-140° F (20-60° C)	ISC1BX	CSCBX----KUXE-	CPM PP	CPMPX----EUCE-	53 or 54
				ISC1PX	CSCPX----KUXE-	11 / 62
				ISC2PP	CSCPP----KUCE-	53 or 54
Caustic Feed (51-70% Sodium Hydroxide)	68-140° F (20-60° C)	ISC1BX	CSCBX----KUXE-	CPM PP	CPMPX----KUCE-	53 or 54
				ISC1PX	CSCPX----KUXE-	11 / 62
				ISC2PP	CSCPP----KUCE-	53 or 54
Hydrochloric Acid (<2%)	32-122° F (0-50° C)	ISC1BX	CSCBX----ICXV-	CPM PP	CPMPX----KUCE-	53 or 54
				ISC1PX	CSCPX----ICXV-	11
				ISC2PP	CSCPP----ICXV-	11
Hydrochloric Acid (<10%)	32-68 F (0-20° C)	ISC1BX	CSCBX----ICXV-	CPM PX	CPMPX----ICXV-	11
				ISC1PX	CSCPX----ICXV-	11
Hydrochloric Acid (<37%)	32-122° F (0-50° C)	None	None	RO	H75HFVV	11
Sulfuric Acid (0-90%)	77-104° F (25-40° C)	ISC1BX	CSCBX----KCXV-	ISC1PX	CSCPX----KCXV-	11, 13, or 32
Sulfuric Acid (90-100%)	77-104° F (25-40° C)	ISC1BX	CSCBX----KAXV-	CPM PX	CPMPX----KCXV-	11, 13, or 32
				ISC1PX	CSCPX----KAXV-	11, 13, or 32
				CPM PX	CPMPX----KAXV-	11, 13, or 32
Side Arm Transfer	32-230° F (0-110° C)	None	None	ISC2PP	CSCPP----ETTA-	53 or 54
Mud & Fat Transfer	32-176° F (0-80° C)	None	None	CPM PP	CPMPX----EUUA-	53 or 54
				ISC2PP	CSCPP----ETTV-	53 or 54
Glucose Transfer	32-122° F (0-50° C)	None	None	CPM PP	CPMPX----EUUV-	53 or 54
				ISC2PP	CSCPP----EUCV-	53 or 54
Lime Slurry (<40%)	<95° F (<35° C)	ISC1BX	CSCBX----DCXV-	CPM PP	CPMPX----EUCV-	53 or 54
				ISC1PX	CSCPX----ECXV-	11, 13, or 32
				CPM PX	CPMPX----ECXV-	11, 13, or 32
Soda Ash (<35%)	<140° F (<60° C)	ISC1BX	CSCBX----ECXV-	SLM-6000 QCD	B(2/V)2BQVV	11 / 62
				SLM-6000 SLD	B(2/V)2BQVV	11 / 62
				ISC1PX	CSCPX----ECXV-	11, 13, or 32
				CPM PX	CPMPX ---ECXV-	11, 13, or 32
Fuel Oil	59-95° F (15-35° C)	ISC1BX	CSCBX---ECXV-	SLM-6000 QCD	B(2/V)2BQVV	11 / 62
				SLM-6000 SLD	B(2/V)2BQVV	11 / 62
				ISC1PX	CSCPX----ECXV-	11, 13, or 32
				ISC1EX	CSCEX----ECXV-	11, 13, or 32
Fusel Oil	59-95° F (15-35° C)	None	None	CPM PX	CPMPX----ECXV-	11, 13, or 32
				ISC2PP	CSCPP----ECCA-	53 or 54
				CPM PP	CPMPX----ECCA-	53 or 54
Boiler Feed Water	<250° F (<121° C)	ISC1BX	CSCBX---ECXV-	ISC1PX	CSCPX----ECXV-	11
				CPM PX	CPMPX----ECXV-	11
Boiler Feed Water	>250° F (>121° C)	None	None	QB	5U4X	32
Beer Fermentation	122-194° F (50-90° C)	ISC1BX	CSCBX----ECXV-	ISC1PX	CSCPX----ECXV-	11
				ISC1EX	CSCEX----ECXV-	11
				CPM PX	CPMPX----ECXV-	11
Ethanol (Ethyl Alcohol)	95-176° F (35-80° C)	ISC1BX	CSCBX----ECXE-	ISC1PX	CSCPX----ECXE-	11
				CPM PX	CPMPX----ECXE-	11
		ISC2BB	CSCBB----ECCE-	53 or 54		
				CPM PP	CPMPX----ECCE-	53 or 54

^A The CPM materials shown are traditional recommendations. Graphitized Sintered Silicon Carbide versus Direct Sintered Silicon Carbide seal faces and TFE-Propylene secondary seals are available and should be considered for appropriate applications.

^B The flush plans listed target providing seal faces with clean and cool environments. Alternate seal face selections may require reassessment of the flush plan to ensure a clean and cool environment.

Seal Material Code Definitions

Flowserve 14 Digit Material Code - ISC Series and CPM Series Designs

1 st Digit (Program)	2 nd Digit (Standardization)	3 rd Digit (Standardization)	4 th / 5 th Digits (Seal Type)	6 th to 9 th Digits (Shaft/Seal Size)
C Complete ISC C CPM Series	P CPM Series S ISC Series	C Std ISC Elastomers M CPM Series	BB Dual Rotating Bellows BX Single Rotating Bellows EX Single Elastomer Bellows PP Dual Pusher PX Single Pusher	Example = 1375 for 1.375 Inch
10 th Digit (Gland/Sleeve Material)	11 th / 12 th Digits (Seal Face Combinations)		13 th Digit (Elastomers)	14 th Digit (Gland Configuration)
B 20 SS IB / 316 SS Gland D C-276 IB / 316 SS Gland E All 316 SS I All C-276 K All 20 SS	A Silicon Carbide / Silicon Carbide C Silicon Carbide / Carbon F Tungsten Carbide / Food Grade Carbon T Tungsten Carbide / Tungsten Carbide U Silicon Carbide / Tungsten Carbide X Filler (Single Seals Only) Z Carbon / Tungsten Carbide (IB Only)		A TFE-Propylene (Aflas [®]) E EPDM (EPR) V Fluoroelastomer (FKM)	B Enlarged Bore E Elliptical Gland I IDP Gland R Reverse Rotation S Standard Bore

Flowserve 7 Digit Material Code - SLM Series Designs

1 st Digit (Sleeve)	2 nd Digit (Rotor)	3 rd Digit (Stator)	4 th Digit (Gland)	5 th Digit (Gland Features)	6 th / 7 th Digits (Secondary Seals)
B Duplex 255 (CD4MCuN) E 316 SS I C-276 L High-Chrome Iron	2 Direct Sintered Silicon carbide 4 Reaction Bonded Silicon Carbide U Nickel Bound Tungsten Carbide V Fluoroelastomer (FKM) E EPDM (EPR) O Buna-N	2 Direct Sintered Silicon Carbide 4 Reaction Bonded Silicon Carbide U Nickel Bound Tungsten Carbide	B Duplex 255 (CD4MCuN) E 316 SS I C-276 L High-Chrome Iron	P Plain (Non-Lube) Q Quenching	E EPDM (EPR) L-AQ3 TFE-Propylene (FEPM) V Fluoroelastomer (FKM)

Flowserve 7 Digit Material Code - PSS II Designs

1 st Digit (Collar)	2 nd Digit (Stator)	3 rd Digit (Rotor)	4 th Digit (Gland)	5 th Digit (Gland Features)	6 th / 7 th Digits (Stator/Rotor Mounting)
E 316 SS K 20SS	2 Direct Sintered Silicon Carbide 4 Reaction Bonded Silicon Carbide R Resin Carbon	2 Direct Sintered Silicon Carbide 7 Aluminum Oxide	E 316 SS K 20 SS	F Flush	E EPDM (EPR) L-AQ3 TFE-Propylene (FEPM) V Fluoroelastomer (FKM)

* Springs, drive pins, and other selected parts may be upgraded without changing the metal parts Digit.

Flowserve 7 Digit Material Code - MSS and RO Designs

1st Digit (Rotary Unit)	2nd Digit (Rotor)	3rd Digit (Stator)	4th Digit (Gland)	5th Digit (Gland Features)	6th / 7th Digits (Secondary Seals)
E 316 SS	2 Direct Sintered	2 Direct Sintered	E 316 SS	F Flush	E EPDM (EPR)
H Alloy B	Silicon Carbide	Silicon Carbide	H Alloy B	F/V Flush, Vent, & Drain	L-AQ3 TFE-Propylene (FEPM)
I C-276	4 Reaction Bonded	4 Reaction Bonded	I C-276	P Plain (Non-Lube)	V Fluoroelastomer (FKM)
K 20 SS	Silicon Carbide	Silicon Carbide	K 20 SS	Q Quenching	
	7 Peramic	5 Resin Carbon		V Throttle Bushing, Vent, & Drain	
	R Resin Carbon	7 Peramic			
	U Nickel Bound	U Nickel Bound			
	Tungsten Carbide	Tungsten Carbide			

Flowserve 4 Digit Material Code - QB Series Designs

1st Digit (Metal Parts*)	2nd Digit (Rotating Face)	3rd Digit (Gaskets)	4th Digit (Stationary Face)
5 316 SS DB	A Resin Carbon	GE 1 Nitrile	GS N Nickel Bound LV
6 20 SS DY	U Antimony Carbon	RY 3 Perfluoroelastomer	ZV Tungsten Carbide
7 Alloy 400 HU		4 Fluoroelastomer (FKM)	X Reaction Bonded SL
9 C-276 NL		5 Ethylene Propylene (EPDM)	GU Silicon Carbide
F Duplex DX 2205		9 Perfluoroelastomer (FFKM)	MG Z Direct Sintered YO
		A TFE-Propylene (FEPM)	AD Silicon Carbide
		D Perfluoroelastomer (FFKM)	AF
			TW

* Springs, drive pins, and other selected parts may be upgraded without changing the metal parts Digit.

Glossary¹¹

A

Acidity – The amount of alkali needed to neutralize the acid level in a solution.

Alkalinity – The amount of acid needed to neutralize the alkaline level in a solution.

Ambient Conditions – The environmental conditions without applying any additional heating or cooling.

Amylose – The component of starch where anhydroglucose units are linked by glucose bonds. The level and molecular weight of amylose vary between different types of starches. Aqueous solutions of amylose can be unstable due to its structure which can increase viscosity and cause particles to precipitate out of solution.

Amylopectin – A component of starch with a polymer type or branched structure. Aqueous solutions of amylopectin usually provide high viscosity, clarity, stability, and resistance to gelling. The level of amylopectin varies between different types of starches. Waxy starches are almost 100% amylopectin.

Ash – The inorganic mineral residue resulting from complete combustion under defined conditions.

C

Carbohydrate – A chemical compound containing only the elements carbon, hydrogen, and oxygen. Cellulose, starch, and sugar are examples of carbohydrates.

Chaff – Fibrous debris removed before and sometimes during wet mill processing.

Chemical Gelatinization – Starch can be gelatinized in an aqueous solution by heating it or treating it with proper chemicals. The most common chemical gelatinization is to treat of starch with an alkali such as caustic soda.

Clarity – An indicator of the transparency level. For starch paste and syrup, it is measured by a number of methods based on light transmission.

Condensate – Material transformed from a gaseous phase to a liquid phase during processing.

Corn Gluten Feed – A commercial by-product from corn wet milling which includes fiber, gluten, starch, and oil.

Corn Gluten Meal – A commercial by-product from corn wet milling that includes fiber, gluten, starch, and oil. It is similar to corn gluten feed but has a higher gluten level.

Corn Oil – Corn oil is a by-product of the corn wet milling process produced by extracting and refining the germ oil.

Corn Starch – A complex carbohydrate extracted from corn during the wet milling process.

Corn Steep Liquor – The aqueous liquor resulting from corn steeping. It is concentrated before supplied as a

fermentation feedstock. It contains lactic acid, amino acids, peptides, proteins, carbohydrates, vitamins, trace metals, and minerals.

Corn Syrup – Also known as glucose syrup. This purified and concentrated solution is made from corn starch.

Cotyledon – The part of the seed plant embryo that enlarges upon germination and produces green leaves upon growth.

Crude Fiber – An insoluble cellulose material that may be present at very low levels in starch products.

D

Degradation – The reduction in size of starch molecules with the aid of chemicals or enzymes.

Dextrose – A glucose obtained by the complete hydrolysis of starch and its purification and crystallization.

Drum Dried Starch – Starch made by cooking and drying a starch paste for mill grinding to a desired particle size.

E

Embryo – The fundamental plant or germ enclosed within the corn kernel seed.

Emissions – Contaminants sent to the atmosphere.

Endosperm – A main component of the corn kernel containing most of the starch and protein. It is the nutritive tissue that surrounds and feeds the embryo or germ.

Enzyme – A chemical substance such as bacteria or fungus that is produced by living organisms and used to promote and catalyze specific chemical reactions.

F

Fiber – Term used to describe the predominantly cellulose like material present in a corn husk.

Flash Dryer – A dryer providing a very fast drying action using a flow of hot air.

Food Starch – Any starch, native or modified, used in food applications. All native starches are allowed for food use. Chemically-modified starches for food use are restricted.

G

Gelatinization – The irreversible swelling of starch particles due to the application of heat and/or chemicals in an aqueous solution to produce a starch paste.

Germ – The corn kernel embryo from which oil is extracted for refining into corn oil and other commercial products.

Germ Cake – Residue left over after oil is removed from the corn germ.

Glucose – A sugar found naturally in fruits and vegetables and one of the building blocks of starch.

Glucose Syrup – Also known as corn syrup. This purified and concentrated solution is made from corn starch.

Gluten – The water-insoluble protein extracted from corn. Corn gluten is used in animal feed. It is lighter than water which makes it easily separated out during wet milling.

¹¹ Dictionary of Food Starch Terms; Courtesy of FoodStarch.com; Copyright 2004; National Starch and Company, Bridgewater, NJ, USA

H

High Amylose Starch – A genetic starch that contains over 50% amylose. High amylose starch is highly crystalline and requires high temperatures and/or pressures to achieve full gelatinization. It has strong film forming and gelling capabilities.

High Fructose Corn Syrup – A special type of corn syrup containing a high level of fructose. Enzymes convert starch to dextrose. Additional enzyme application converts the dextrose to fructose.

Hydrolysis – A chemical reaction between a molecule and water to produce two or more smaller molecules. It can occur with the aid of an acid, alkali, or enzyme and is used to convert starch into glucose syrups.

K

Kernel – The corn grain or seed that is found on the cob and enclosed within the husk.

L

Lipids – Although lipids (fats) are mostly removed from corn as oil during wet milling, there is a low level (<1%) of residual lipids (fats) remaining in corn starch.

N

Native Starch – Original unmodified starch obtained through extraction processes. Modified starch is obtained by chemical reactions. New native starches are being developed with many of the properties of modified starches.

P

Pericarp – The outer covering of the corn kernel that protects it from deterioration and disease.

Permeate – The part of a solution that is capable of flowing through a filter.

pH – A universal scale that measures acidity in increasing levels from pH7 to pH0 and alkalinity in increasing levels from pH7 to pH14. pH7 is neutral and represents pure water.

R

Radical Root – The part of the corn kernel's embryo plant that develops into a root.

Retentate – The part of a solution that is held back or retained on the surface of a filter.

S

Seed Coat – Another term to describe the pericarp of a corn kernel, the outer protective coating.

Slurry – A suspension of insoluble fiber in water.

Starch – A granular carbohydrate found in corn as well as wheat, rice, and others plant products. It may have an amylose or an amylopectin structure. Plant species may provide various amounts of amylose and amylopectin to produce differences in paste texture, viscosity, and stability.

Starch Slurry – It is an aqueous solution of unswollen starch particles.

Steeping – The wet milling step that soaks corn kernels in liquid to soften them and prepare them for component extraction.

Steepwater – Liquid that has been used to soak and soften corn in steeping before milling the grain to remove components. After steeping, the steepwater contains dissolved proteins, minerals, and other substances. It is used to produce a gluten feed by-product, an ingredient in animal feed.

Sweetness – Simple sugar sweetness declines as molecular weight increases. A DP3 product is less sweet than a DP2 and a DP2 product is less sweet than a DP1. Product sweetness is compared to pure sucrose under the same conditions.

Swelling Power – A measure of starch hydration. Heating starch irreversibly swells its particles and the amount of swell depends on the starch and the physical or chemical activity.

T

Taste – The taste of natural or modified starch for food use must be neutral. Off flavor starches will alter natural food taste and can result from poor washing processes or conversion of natural fatty acids during chemical reactions.

Tip Cap – The attachment point of the kernel to the corn cob.

W

Washing – A process step used to aid in separating the components of the corn kernel for processing.

Waxy Starch – A starch containing mostly amylopectin. Waxy starches are more stable and can be chemically modified to improve their stability.

Wet Milling – The multi-step process used to separate corn into its component parts.

Y

Yellow Dent Corn – The typical type of corn used in corn wet milling processes.

¹¹ Dictionary of Food Starch Terms; Courtesy of FoodStarch.com; Copyright 2004; National Starch and Company, Bridgewater, NJ, USA

Bibliography

U.S. Corn Production: 1999-2001, Corn Refiners Association, <http://www.corn.org/web/uscprod.htm>
(Reproduced with permission of Corn Refiners Association, Inc.)

Frequently Asked Questions, Corn Refiners Association, <http://www.corn.org/web/faq.htm>
(Reproduced with permission of Corn Refiners Association, Inc.)

The Process (step-by-step), Corn Refiners Association, <http://www.corn.org/web/process.htm>
(Reproduced with permission of Corn Refiners Association, Inc.)

Food and Industrial Corn Use-1980 to Present, Corn Refiners Association, <http://www.corn.org/web/foodseed.htm>
(Reproduced with permission of Corn Refiners Association, Inc.)

The World of Corn 2003, <http://www.ncga.com>

Special Report No. 48, How a Corn Plant Develops, Iowa State University of Science & Technology, <http://maize.agron.iastate.edu/corngrows.html>

Yellow Dent Corn, Walton Feed, <http://waltonfeed.com/self/corn.html>

Corn Annual 2003, Corn Refiners Association, <http://www.corn.org>
(Reproduced with permission of Corn Refiners Association, Inc.)

S. Gunasekaran & D. Farkas, High-Pressure Hydration of Corn, American Society of Agricultural Engineers Paper No. 87-6564, 1988

Ethanol Production Process, Renewable Fuels Association, http://www.ethanolrfa.org/prod_process.html

Dictionary of Food Starch Terms; Courtesy of FoodStarch.com; Copyright 2004; National Starch and Company, NJ, USA

The information and specifications presented in this product brochure are believed to be accurate, but are supplied for information purposes only and should not be considered certified or as a guarantee of satisfactory results by reliance thereon. Nothing contained herein is to be construed as a warranty or guarantee, express or implied, with respect to the product. Although Flowserve Corporation can provide general application guidelines, it cannot provide specific information for all possible applications. The purchaser/user must therefore assume the ultimate responsibility for the proper selection, installation, operation and maintenance of Flowserve products. Because Flowserve Corporation is continually improving and upgrading its product design, the specifications, dimensions and information contained herein are subject to change without notice.

Primary Worldwide Flow Solutions Division Locations

Licensees, authorized agents, and affiliated companies located worldwide.

United States	Canada	Netherlands	Argentina	Australia
Kalamazoo, MI Phone 269-381-2650 Fax 269-382-8726	Edmonton, Alberta Phone 780-464-1188 Fax 780-464-1801	Roosendaal Phone 31-165-581400 Fax 31-165-552622	Buenos Aires Phone 54-11-4709-6800 Fax 54-11-4709-6800 ext 123	Marayong NSW Phone 61-2-8822-7100 Fax 61-2-9679-7511
Singapore	Mexico	Brazil	Japan	Germany
Phone 65-6-8465100 Fax 65-6-7471963	Tlaxcala Phone 52-2-461-6791 Fax 52-2-461-6847	Sao Paulo Phone 55-11-4231-6300 Fax 55-11-4231-6326	Osaka Phone 81-720-85-5571 Fax 81-720-85-5575	Dortmund Phone 49-231-6964-0 Fax 49-231-6964-248

www.flowserve.com

ISO 9000
Certified

FTA162