

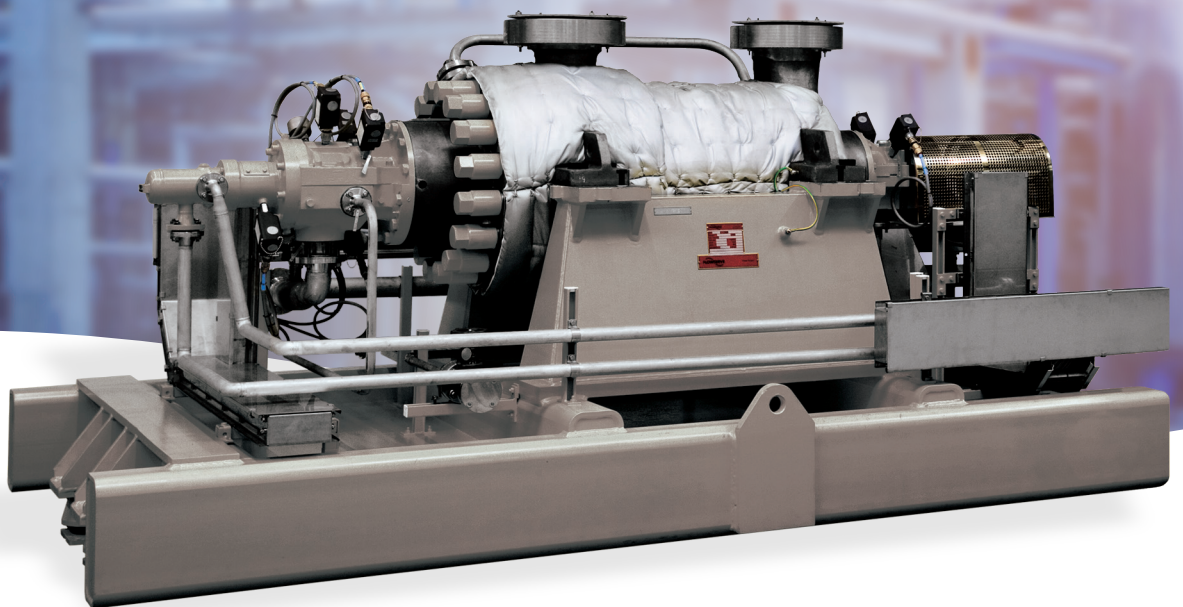

WCC General-Purpose Barrel Pump for the Oil and Gas Industry

ISO 13709/API 610 (BB5)



Experience In Motion



The preferred supplier for oil and gas barrel pumps

For more than 150 years, Flowserve has pioneered virtually every significant advancement in petroleum-related pumping technology. Our ability to understand the industry's high-pressure pumping needs is evidenced by our numerous innovative barrel pump designs, and the WCC pump is no exception.

Rated for discharge pressures to 300 bar (4,350 psi), the WCC is a pre-engineered process barrel pump meeting ISO 13709/API 610 (BB5), latest edition. The design configuration can be customized with numerous options to meet customer specifications.



A foundation of innovation and leadership

Since 1926, when we developed the first double-case pump for hot oil, Flowserve has been in the vanguard of pump development for the oil and gas industry. This leadership position was reinforced in 1934 with the introduction of high-pressure water and CO₂ injection pumps and cemented in 1982 when we built the world's largest water injection pump: a 17,900 kW (24,000 hp) behemoth.

Reflecting our leadership position, Flowserve was heavily involved in establishing the API 610 (BB5) standard governing the construction of double-case pumps. From water injection and pipeline to charge and decoking, Flowserve is the preferred provider of double-case pump technology worldwide.

Flexibility that benefits the bottom line

The WCC is a multistage, diffuser-type barrel pump with a tandem or opposed impeller rotor and a single-diameter balance drum to compensate for residual axial thrust. The standard cartridge-type construction facilitates rapid changeout with a spare to minimize lost production. When process requirements demand a fully compliant, API 610/ISO 13709 pump but also call for a flexible, cost-efficient solution, the WCC is the optimum choice. With its extensive list of options and metallurgical choices, it can fit almost any oil and gas application.

Classified as a general purpose barrel pump, the WCC pump conforms to ISO 13709/API 610 (BB5), latest edition, and is CE and ATEX compliant. Pressure-containing elements are designed to ASME Pressure Vessel Code Section VIII, Div. 1. In addition, Flowserve engineers will work with users to address and incorporate site-specific requirements, while, at minimum, meet the specifications for:

- Mechanical seals to ISO 21049/API 682
- Lubrication systems to API 610 or API 614

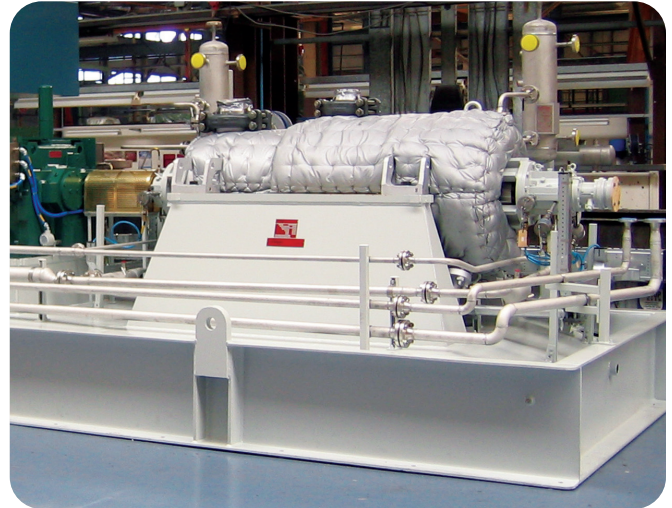

Typical applications

- Water or CO₂ injection
- Pipeline
- Amine feed
- Hydrocarbon charge
- Ethylene feed
- Acid gas reinjection
- Hydraulic power recovery turbine
- Boiler feedwater

Operating parameters

- Flows to 1,000 m³/h (4,500 US gpm)
- Heads to 4,000 m (13,100 ft)
- Pressure rating to 300 bar (4,350 psi)
- Temperatures from -73°C to 425°C (-100°F to 800°F)
- Speeds to 6,500 rpm

For parameters outside these limits, please contact Flowserve.

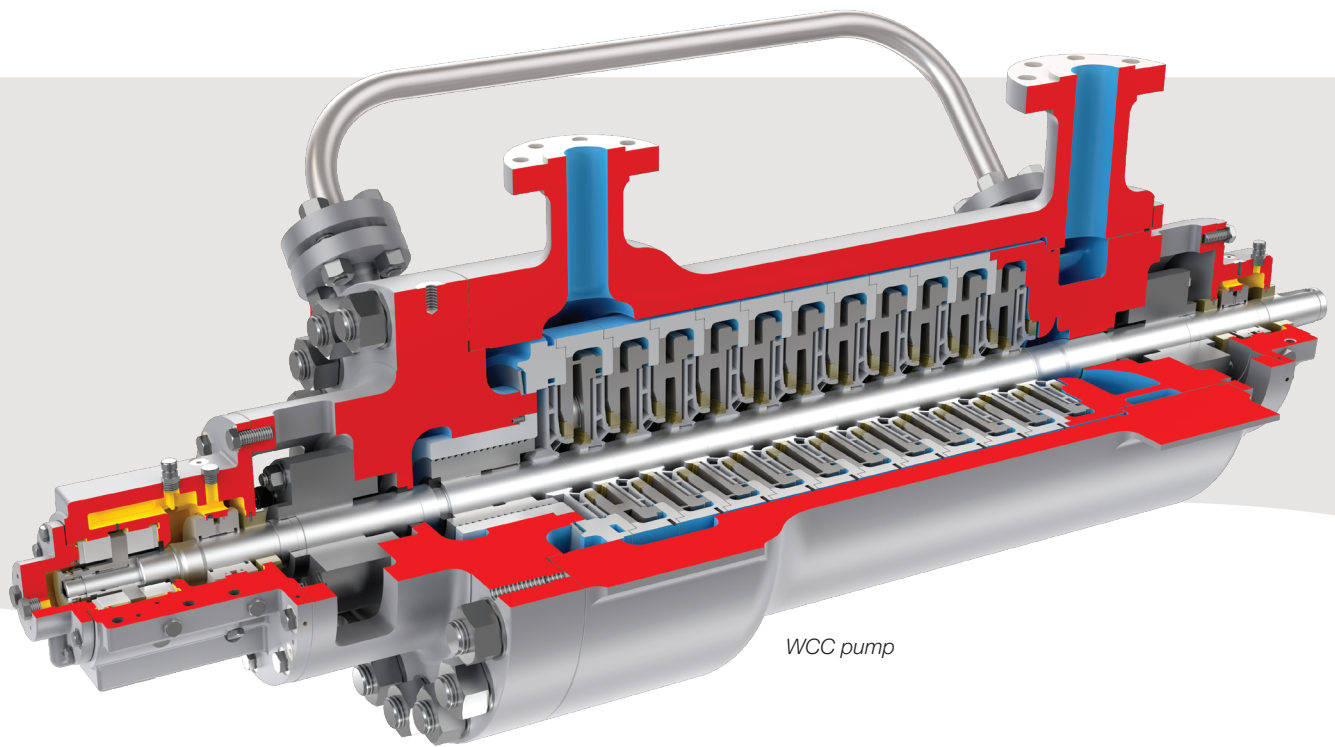

WCC pump

Engineered for performance and flexibility

Wrought shafts are incrementally stepped at each impeller fit for ease of assembly. Shafting is generously sized and machined to tight tolerances to minimize harmful vibrations. The standard shaft extension is a NEMA taper.

Precision-cast impellers ensure optimum hydraulic efficiency and repeatability of performance. Impeller wear surfaces—whether separate wear rings (standard) or integral (optional)—are engineered for the best possible performance. Standard materials can be upgraded with overlay materials like Stellite® or surface treatments like laser hardening for better durability.

Optional grooved impeller running fits increase the pump's tolerance to foreign materials and desensitize it during startup, stopping and system transients.

Proprietary integral cartridge compression device prevents internal leakage over the entire operating range.

Multivane diffusers balance radial loads over the operating range, while maximizing efficiencies at the duty condition. A continuous metal-to-metal seal between stage pieces minimizes risk of internal leakage.

Optional flanged balance drum ensures the ability to operate the pump over a wider range of duty conditions.

Single-diameter balance drum

A single-diameter balance drum compensates for residual axial thrust produced by the tandem impeller arrangement. The drum is designed to be plain or serrated as appropriate for the application to reduce leakage and optimize reliability and efficiency. It is installed via an interference fit against a step in the shaft and located axially with a split ring. A flanged drum design is optional.

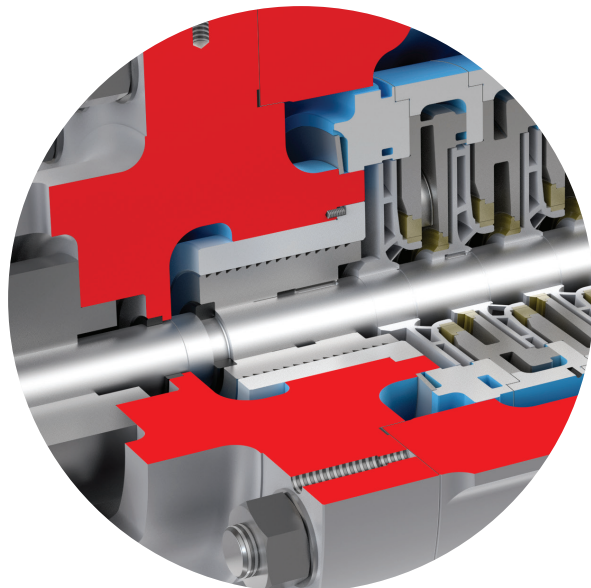

® Stellite is a registered trademark of Deloro Stellite.

Robust bearing system

The WCC pump is offered with a variety of bearing configurations to meet application requirements. For the most demanding applications, the standard bearing system consists of heavy-duty, journal-type radial bearings and self-equalizing, tilting pad thrust bearings due to their reliability and versatility.

The following bearing arrangements are available when permitted by ISO 13709/API 610 (BB5) and applications requirements allow:

- Rolling element thrust bearings may be used in conjunction with either rolling element radial or self-lubricated radial sleeve bearings. Air, fan or water cooling is available as needed to suit the application requirements.
- When space is at a premium, an integral lubrication circulation system can be supplied. This system offers the benefits of circulation while maintaining a compact size and minimizing maintenance demands.



Barrel pressure rating

All pressure boundary components are designed in accordance with ASME standards to meet the application requirements. The suction portion of the WCC barrel pump is engineered as a split pressure rated design. Sealing is metal-to-metal with fully confined, controlled compression gaskets that ensure proper sealing and alignment when handling hot liquids.

Numerous nozzle configurations

The standard nozzle configuration on the WCC pump is top suction, top discharge. It may be configured side suction, side discharge as an alternative.

Flange facing is raised face as standard with ring-type joint optional. Standard flange ratings range from 600 to 2,500 lb to suit the application.

Cartridge-type inner element

The WCC pump features a standard cartridge-type inner element. In this design, the inner element includes the rotor, diffusers, discharge head, suction head and bearing assembly, allowing the entire assembly to be removed as a single unit. This configuration eases maintenance and reduces downtime, allowing major assembly and disassembly in the workshop, rather than in the field.

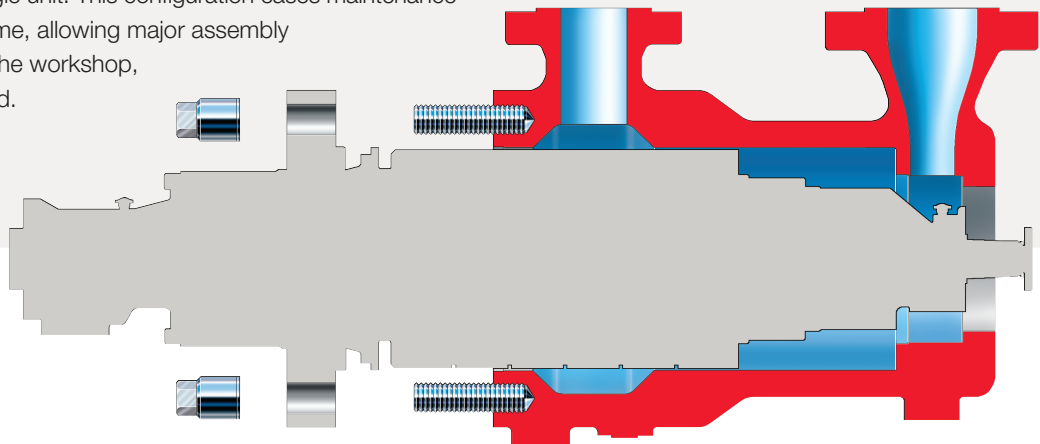

Options and technical data

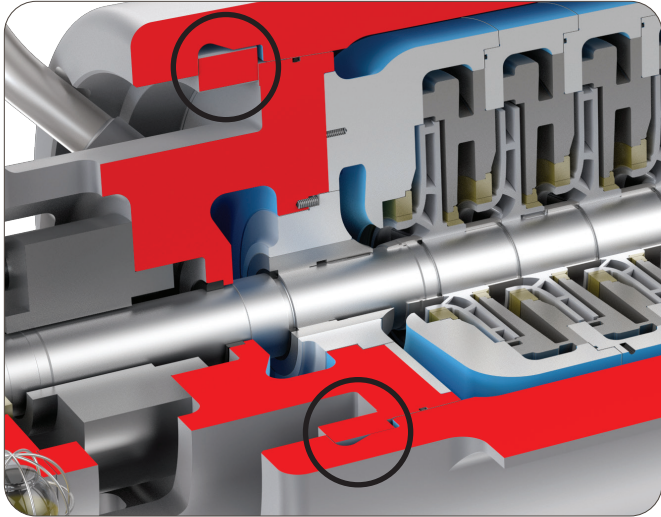

Optional shear ring closure system

A shear ring closure system replaces the traditional bolting on the discharge cover. In this configuration, the high-strength split seal ring is locked into the barrel body by cap nuts. This design maintains cartridge integrity but still allows maintenance with conventional tooling. The shear ring design is more compact and boasts one of the quickest maintenance turnarounds in the industry.

Optional back-to-back rotor design

Optional back-to-back rotor design ensures hydraulic balancing of the axial thrust. The center bushing and sleeve assure improved rotor dynamics by adding rotor stability and low vibration levels for higher stage counts, even for low-density applications.

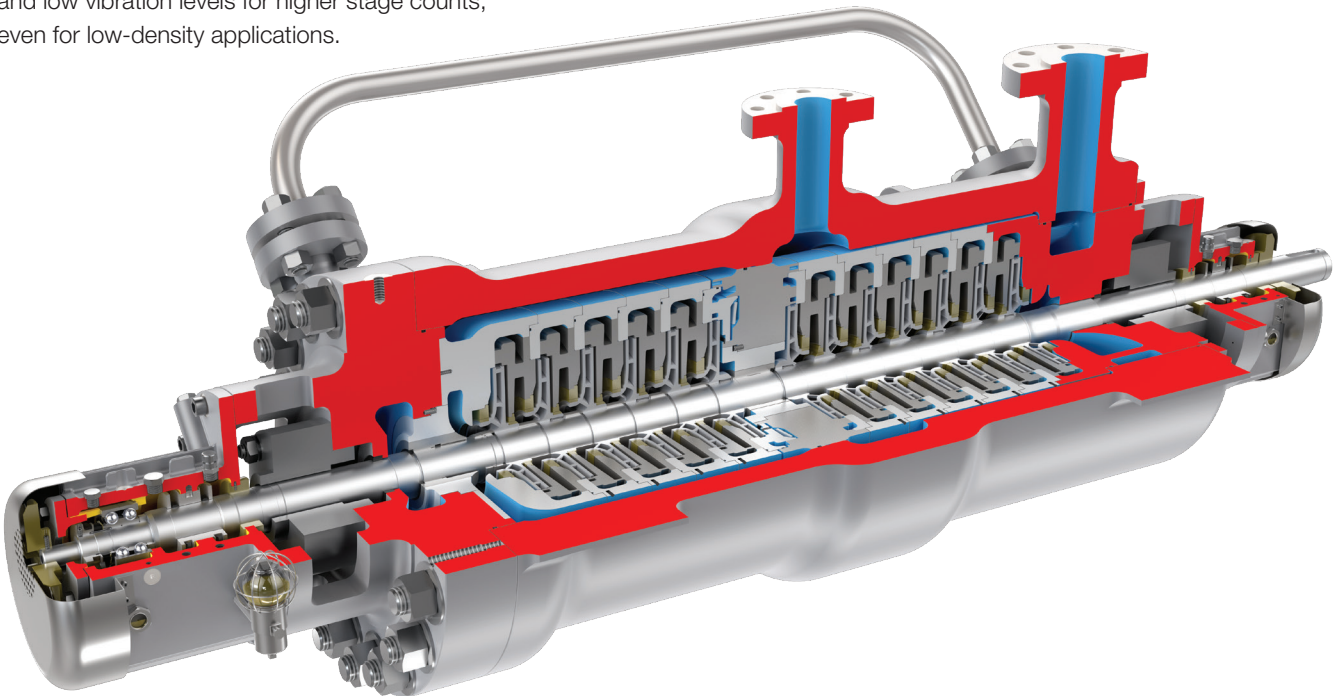

Materials of construction

The materials of construction of the WCC pump's barrel casing and discharge head meet ISO 13709/API 610, latest edition, Column S-6 and above. They include:

- Carbon steel
- High-chrome steel
- Austenitic stainless steel
- Duplex stainless steel
- Super duplex stainless steel

Special materials to meet customer requests or specific application requirements are available.

Tested to ensure performance

Each WCC pump is performance tested in accordance with API and Hydraulic Institute testing standards to ensure the unit meets the specified design conditions. Pumps can be tested at full flow, pressure and speed, up to 18,650 kW (25,000 hp).

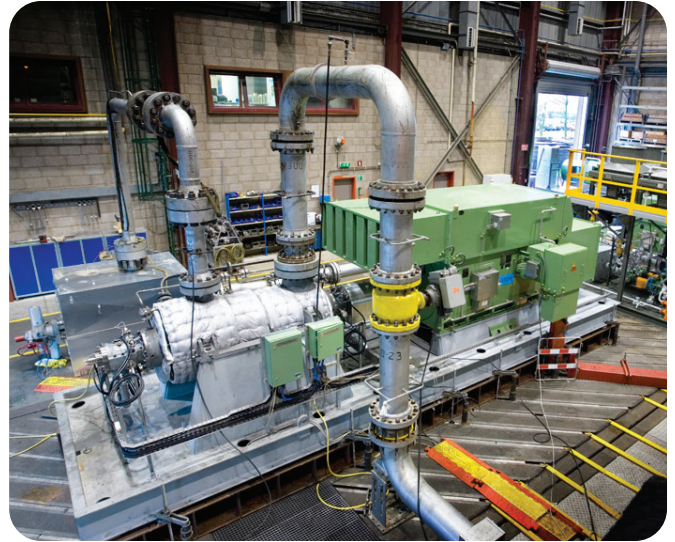

Advanced close-clearance technologies

For severe services, the WCC pump is available with state-of-the-art, erosion- and abrasion-resistant materials in the running fits. These materials are applied by various processes to ensure the ultimate in reliability for even the harshest environments:

- Through hardening: Metallurgically alters the microstructure of the metal component, resulting in a solid hard wearing part.
- Super-hard overlay: A second material possessing the desired wear characteristics, like tungsten carbide or Stellite 6, is overlaid onto the base metal via the HVOF or direct laser deposit processes.
- Non-metallic and ceramic materials

Flowserve will advise which materials and processes are recommended based on the specifics of the actual application.

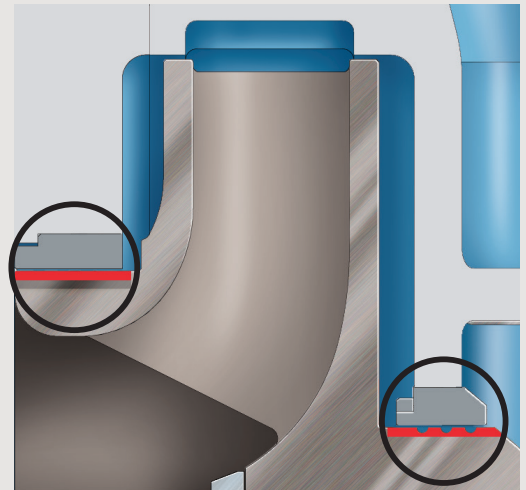

Optional grooved wear surface shown on impeller hub



Flowserve Corporation
5215 North O'Connor Blvd.
Suite 2300
Irving, Texas 75039-5421 USA
Telephone: +1 937 890 5839

Flowserve Corporation has established industry leadership in the design and manufacture of its products. When properly selected, this Flowserve product is designed to perform its intended function safely during its useful life. However, the purchaser or user of Flowserve products should be aware that Flowserve products might be used in numerous applications under a wide variety of industrial service conditions. Although Flowserve can provide general guidelines, it cannot provide specific data and warnings for all possible applications. The purchaser/user must therefore assume the ultimate responsibility for the proper sizing and selection, installation, operation, and maintenance of Flowserve products. The purchaser/user should read and understand the Installation Instructions included with the product, and train its employees and contractors in the safe use of Flowserve products in connection with the specific application.

While the information and specifications contained in this literature are believed to be accurate, they are supplied for informative purposes only and should not be considered certified or as a guarantee of satisfactory results by reliance thereon. Nothing contained herein is to be construed as a warranty or guarantee, express or implied, regarding any matter with respect to this product. Because Flowserve is continually improving and upgrading its product design, the specifications, dimensions and information contained herein are subject to change without notice. Should any question arise concerning these provisions, the purchaser/user should contact Flowserve Corporation at any one of its worldwide operations or offices.

©2020 Flowserve Corporation. All rights reserved. This document contains registered and unregistered trademarks of Flowserve Corporation. Other company, product, or service names may be trademarks or service marks of their respective companies.

PUBR000066-03 (EN/AQ) November 2020