



# *USER INSTRUCTIONS*

## *Valtek VL-ES Actuators*

*FCD VLENIM0114-01 – 05/13*

*Installation  
Operation  
Maintenance*



*Experience In Motion*

# Contents

1	General Information	3
1.1	Using	3
1.2	Applicability	3
1.3	Terms Concerning Safety	3
1.4	Protective Clothing	3
1.5	Qualified Personnel	4
1.6	Installation	4
1.7	Spare Parts	4
1.8	Service / Repair	4
1.9	Storage	5
1.10	Product Variations	5
2	Unpacking	5
3	Valve Installation	5
4	Dissassembly of VL-ES Actuator	6
5	Assembly of the VL-ES Actuator	7
6	Maintenance	10
7	Decommissioning the Spring-Can	11

# 1 General Information

## 1.1 Using

The following instructions are designed to assist in disassembling, reassembling and troubleshooting Flowserve Valtek valves equipped with VL-ES actuators. Separate installation, operation and maintenance instructions cover additional features (such as handwheels, limit stops, fail-safe systems, limit switches or positioners). Product users and maintenance personnel should thoroughly review this bulletin in conjunction with any handwheels or other accessory equipment before installing, operating or performing any maintenance on the valve. In most cases, Flowserve valves, actuators and accessories are designed for specific applications (e.g. with regard to medium, pressure, temperature). For this reason they should not be used in other applications without first contacting the manufacturer.

## 1.2 Applicability

The following instructions are applicable to the maintenance and installation of VL-ES actuators only. This document should be used in conjunction with the appropriate Installation, Operation and Maintenance Instructions specific to the model of the valve on which the actuator is installed.

## 1.3 Terms Concerning Safety

The safety terms DANGER, WARNING, CAUTION and NOTE are used in these instructions to highlight particular dangers and/or to provide additional information on aspects that may not be readily apparent.

☠ **DANGER:** indicates that death, severe personal injury and/or substantial property damage will occur if proper precautions are not taken.

⚠ **WARNING:** indicates that death, severe personal injury and/or substantial property damage can occur if proper precautions are not taken.

⚡ **CAUTION:** indicates that minor personal injury and/or property damage can occur if proper precautions are not taken.

**NOTE:** indicates and provides additional technical information which may not be obvious, even to qualified personnel.

Compliance with other notes, which may not be particularly emphasized, with regard to transport, assembly, operation and maintenance and with regard to technical documentation (e.g. in the operating instructions, product documentation or on the product itself), is essential in order to avoid faults, which, in and of themselves may directly or indirectly cause severe personal injury or property damage.

## 1.4 Protective Clothing

Flowserve products are often used in problematic applications (e.g. under extremely high pressures or with dangerous, toxic or corrosive mediums). When performing service, inspection or repair operations, always ensure that the valve and actuator are depressurized and that the valve has been cleaned and is free from harmful substances. In such cases, pay particular attention to personal protection (e.g. protective clothing, gloves, glasses and respirator as required).

## 1.5 Qualified Personnel

Qualified personnel are people who, on account of their training, experience, instruction and knowledge of relevant standards, specifications, accident prevention regulations and operating conditions, have been authorized by those responsible for the safety of the plant to perform the necessary work and who are able to recognize and avoid possible dangers.

- ☠ **DANGER:** Before installation, check the order number, serial number and/or the tag number to ensure that the valve/actuator is correct for the intended application.
- ⚠ **WARNING:** Standard industry safety practices must be followed when working on this or any process control product. Specifically, personal protection and lifting devices must be used as warranted.

## 1.6 Installation

- 1.6.1 Do not insulate extensions that are provided for hot or cold services.
- 1.6.2 Pipelines must be correctly aligned to ensure that the valve is not fitted under tension.
- 1.6.3 The user must provide fire protection.

## 1.7 Spare Parts

Use only Flowserve original spare parts. Flowserve cannot accept responsibility for any damages that occur from using spare parts or fastening materials from other manufactures. If Flowserve products (especially sealing materials) have been on store for long periods of time check these products for corrosion or deterioration before using them. The end user must provide fire protection for Flowserve products.

## 1.8 Service / Repair

To avoid possible injury to personnel or damage to products, the safety terms must be strictly adhered to (see Section 1.3). Modifying this product, substituting non-factory parts, or using maintenance procedures other than those outlined in this instruction manual can drastically affect performance, be hazardous to personnel and equipment, and may void existing warranties. Between the actuator and the valve there are moving parts. To avoid injury, Flowserve provides pinch-point-protection in the form of cover plates, especially where side-mounted positioners are fitted. If these plates are removed for inspection, service or repair special attention is required. After completing work the cover plates must be refitted. Apart from the operating instructions and the obligatory accident prevention directives valid in the country of use, all recognized regulations for safety and good engineering practices must be followed.

- ⚠ **WARNING:** Before products are returned to Flowserve for repair or service, Flowserve must be provided with an MSDS (Material Safety Data Sheet) and a certificate, which confirms that the product has been decontaminated. Flowserve will not accept deliveries if the MSDS and the certificate have not been provided (a form can be obtained from Flowserve). Since the packing box cannot be cleaned without removing packing, valve packing should be removed and the packing area flushed as part of the cleaning.

## 1.9 Storage

In most cases, Flowserve products are manufactured from stainless steel. Products not manufactured from stainless steel are provided with an epoxy resin coating. This means that Flowserve products are well protected from corrosion. Nevertheless, Flowserve products must be adequately stored in a clean, dry environment. Plastic caps are fitted to protect the flange faces by preventing the ingress of foreign materials. These caps should not be removed until the valve is actually mounted into the system.

## 1.10 Product Variations

These instructions cannot claim to cover all the details of every possible product variation, nor in particular can they provide information for every possible example of installation, operation and maintenance. This means that the instructions normally include only the directions to be followed by qualified personnel using the product for its defined purpose. If there are any uncertainties in this respect, particularly in the event of missing product related information, clarification must be obtained via the appropriate Flowserve sales office.

# 2 Unpacking

While unpacking the actuator, check the packing list against the materials received. Lists describing the actuator and accessories are included in each shipping container.

2.1 Position the lifting straps and hoist to avoid damage to the tubing and mounted accessories when lifting the actuator from the shipping container.

⚠ **WARNING:** When lifting an actuator with lifting straps through the yoke legs, be aware that the center of gravity may be above the lifting point. Therefore, support must be given to prevent the actuator from rotating, causing serious injury to personnel or damage to nearby equipment.

2.2 Contact your shipper immediately in the event of shipping damage.

2.3 Contact your Flowserve representative with any other problems.

# 3 Valve Installation

Prior to installation, make sure adequate overhead clearance is provided for the actuator to allow for proper removal from the valve body and for proper maintenance. Refer to Table I.

Table I: Disassembly Clearance

Actuator Size	Spring	Disassembly Clearance	
		in.	mm
100	Standard	9	229
150	Standard	9	229
150	Heavy Duty	9	229
200	Standard	9	229
200	Heavy Duty	9	229
300	Standard	9	229
300	Heavy Duty	9	229
400	Standard	9	229
400	Heavy Duty	9	229

- 3.1 Make sure the positioner mounting bolts, linkage and stem clamp are fastened securely.
- 3.2 Ensure all accessories, brackets and associated bolting are fastened securely.
- 3.3 Check rubber bellows for wear.
- 3.4 Spray soap solution around the base and top of the cylinder, lower actuator stem bushing and the piston stem bushings to check for air leaks through the O-rings.
- 3.5 Clean any dirt or foreign material from the actuator and piston stems.
- 3.6 If an air filter is supplied, isolate the air filter, then check and replace the cartridge as necessary.

## 4 Dissassembly of VL-ES Actuator

To disassemble the VL-ES actuator, refer to Figure 1 and 2 and then proceed as follows:

- 4.1 Shut off the air supply. If the actuator is installed on a Flowserve valve, remove the valve using the appropriate Installation Operation and Maintenance instructions.
  - ⚠ **WARNING:** To avoid serious injury, depressurize the line to atmospheric pressure and drain all fluids before working on the actuator.
- 4.2 Disconnect all tubing.
- 4.3 Remove the actuator from the valve body using air in the cylinder to move the plug stem to approximately mid stroke position. Remove the stem clamp and release the air from the cylinder slowly. Remove the yoke bolts. Using lifting rings in the place of two of the top plate bolts, lift the actuator up off the valve body subassembly. Set the actuator on a workbench or other sturdy work surface.
  - ⚠ **WARNING:** When lifting an actuator with lifting straps through the yoke legs, be aware that the center of gravity may be above the lifting point. Therefore, support must be given to prevent the actuator from rotating, causing serious injury to personnel or damage to nearby equipment.
  - ⚠ **WARNING:** Removing the stem clamp without relieving the pressure between the plug stem and the actuator stem can cause the stem clamp to suddenly jump, causing serious injury to personnel or damage to nearby equipment.
- 4.4 Remove the cover plate bolts, cover plate and cover plate O-ring.
- 4.5 For fail open, air to close (ATC) actuators, apply air the bottom port on the actuator, moving the piston to the top of the cylinder. Remove the piston stem half rings, collar and thrust washer.
- 4.6 Remove all but two of the spring-can bolts. Leave in two bolts on opposite sides of the actuator. Remove the two remaining bolts one flat at a time, turning each in order. Remove the spring-can by lifting it clear of the actuator.
  - ⚠ **DANGER:** The spring-can contains a pre-tensioned spring. The spring-can must not be disassembled in the field and requires special equipment and training to service. Disassembling the spring-can will cause serious injury or death. For instructions on decommissioning the spring-can, see section 7.0 below.
- 4.7 For fail closed, air to open (ATO) actuators, remove the spring guide and thrust washer.
- 4.8 Remove the four self-locking tie rod nuts by unscrewing them in an alternating pattern. Remove the cylinder end cap.

**NOTE:** When removing the tie rods, spinning the self-locking nuts may cause the entire rod to turn, removing the rods instead of the nuts. In this case, do not use vise-grip pliers or a similar device to keep the rod from turning. This will damage the surface of the tie rod and can cause the rod to fail in service. Instead allow the rod and nut to come out as one. Once the rod and nut are clear, use a soft grip vise to turn the nut off the tie-rod.

- 4.9 If the tie-rods did not come out with the locknuts, remove the tie rods from the yoke using two nuts locked together on the upper threads.
- 4.10 Lift the cylinder off the yoke and piston. If excessive O-ring resistance is felt, use a rubber mallet to gently tap around the cylinder perimeter and gently pry the cylinder off with a flat screwdriver. Remove the piston quad-seal, and two cylinder O-rings.
- ⚠ **WARNING:** To avoid serious personal injury, never use air pressure to remove the piston. The piston may fly out of the cylinder.
- 4.11 Remove the piston assembly.
- 4.12 Remove the piston stem, piston and piston O-ring from the actuator stem.
- 4.13 Remove the O-rings seals from the yoke and end cap.
- 4.14 The bushings in the yoke and end cap can be pushed out with a press if worn or damaged.

## 5 Assembly of the VL-ES Actuator

The quad seal and all of the O-rings should be replaced and lubricated with a calcium complex grease (Dow 55 or equivalent). Silicone O-rings must be lubricated with Magnalube-G lubricant or equivalent.

- 5.1 Inspect the bushing in the yoke and end cap for damage or excessive wear. Use Table II to determine if the bushings are useable. Excessive wear on these bushings will affect the cycle life of the actuator. Replace the bushing if necessary.

Table II: Bushing Tolerances

Actuator Size	Actuator Stem Bushing				Piston Stem Bushing			
	Minimum		Maximum		Minimum		Maximum	
	in.	mm	in.	mm	in.	mm	in.	mm
100	2.252	57.20	2.257	57.33	2.252	57.20	2.257	57.33
200	2.252	57.20	2.257	57.33	2.252	57.20	2.257	57.33
300	2.751	69.88	2.757	70.03	2.751	69.88	2.757	70.03
400	2.751	69.88	2.757	70.03	2.751	69.88	2.757	70.03

### 5.2 Replacing the yoke and end cap bushings

- 5.2.1 Remove the old bushings using a press and properly sized pushrods. Take note that the bushings only push out from one side.
- 5.2.2 Set the inside bushing by pressing it down to contact the step in the hole. The smaller bushing is pressed in first. Some bushings may be interchangeable.
- 5.2.3 Set the outside bushing to be flush with the surface. This provides the correct clearance for the O-ring to be installed later.

5.3 Inspect the piston stem, actuator stem, piston O-ring and piston for damage or wear. Assemble the piston assembly using Loctite® 266 thread locking compound or equivalent. During assembly, a vice may be used to hold the actuator stem, if desired.

**NOTE:** When using a vise grip to hold the actuator stem, take care not to damage the stem threads.

5.4 Lubricate and install the four O-rings for the yoke and yoke cap. Lubricate the bushings in the yoke and yoke cap with a light coat of grease.

5.5 Insert the piston assembly into the yoke and cylinder. A threaded hole in the piston stem has been provided as a lifting point. Generously lubricate the piston quad seal and install into the piston. The grease should fill the valley between each of the quad seal lobes. Install the protective rubber bellows on the actuator stem.

5.6 Lubricate the inside of the cylinder with a light coat of grease. Install the cylinder onto the yoke and piston assembly. Use a soft mallet to gently tap the cylinder into place.

**NOTE:** Care must be taken as the cylinder and top cap are installed or the O-rings and quad seal can be pinched. This will cause damage to the seals, which must then be replaced. Used quad seals will swell somewhat due the effects of the lubricant and new seals should be used whenever the actuator is reassembled.

5.7 Install the tie rods into the yoke using a removable thread-locker (Blue® 266 thread locking compound or equivalent). Using two nuts, jammed together, on the top threads of the tie rod will make installing these rods easier. Remove any nuts used to screw the rods into the yoke.

5.8 Install the end cap onto the piston stem and the cylinder. Take care to line up the air holes on both the yoke and the end cap.

⚠ **WARNING:** Damaged tie rods can fail, causing injury, property damage or death. Damaged tie rods should be replaced. Do not use vice grips or similar devices which can leave scores and dents in the surface of the tie rod. Chipped paint should be repainted.

⚠ **WARNING:** Tie rods must be fully threaded into the yoke. The tie rod must be flush, or extend slightly beyond the bottom of the yoke.

5.9 Install and tighten the tie rod lock nuts. Then loosen the lock nuts by one turn.

5.10 Using the minimum air supply required, stroke the actuator three times. This provides alignment between the upper and lower stem bushings.

5.11 Tighten the tie rod nuts using Table III to obtain the proper torque values.

Table III: Tie Rod Torque Values

Cylinder Size	Torque for Min. Assy Force (ft-lb)	Torque for Min. Assy Force (Nm)
100	73	99
150	110	149
200	142	193
300	241	327
400	293	397

5.12 For ATO, fail closed actuators, lubricate the thrust washer on both sides with a calcium complex grease and install both the spring guide and thrust washer.



- 5.13 Set the spring-can onto the cylinder assembly. Using appropriate anti-seize compound, install two opposing spring-can bolts and lock washers, tightening half a turn at a time to bring the spring-can down evenly onto the cylinder. Install and torque the remaining spring-can bolts and lock washers, again using appropriate anti-seize compound.
- 5.14 For ATC, fail open actuators, stroke the actuator open using the low pressure air. Lubricate the thrust washer with a calcium complex grease on both sides. Install the collar, thrust washer and half rings. The half rings are slightly bent to keep them locked into place. They will need to be gently tapped into place to squeeze them into the groove. Slowly release the air from the cylinder, locking the half rings into place.
- 5.15 Install the positioner, tubing and other accessories. Use of an air filter is always recommended. Use a soap solution to make sure all air connections are leak-free.
- 5.16 Install the maximum air supply pressure sticker and regulator if required.

**NOTE:** In some cases, air supply must be limited; this will be indicated by a sticker found near the upper air port on the cylinder.

⚠ **WARNING:** To avoid personal injury or equipment damage, do not exceed the recommended supply pressure.

- 5.17 Lower the actuator onto the valve body using lifting rings in place of two opposing cover plate holes and install the yoke bolts finger tight. Replace the lifting lugs with the bolts and lock washers using appropriate anti-seize. If the actuator uses a single piece stem clamp, this must be put over the plug stem before the actuator is installed.

⚠ **WARNING:** When lifting an actuator with lifting straps through the yoke legs, be aware that the center of gravity may be above the lifting point. Therefore, support must be given to prevent the actuator from rotating, causing serious injury to personnel or damage to nearby equipment.

- 5.18 Most VL-ES actuators use a split stem clamp. This clamp comes in two pieces and has male threads on the actuator and plug stem. One piece stem clamps have female threads in the actuator stem.
- 5.19 For split stem clamps:
  - 5.19.1 Make sure the plug is firmly seated into the seat ring. Using air, stroke the actuator stem down until it is about 1/8" from the plug stem. Install the stem clamp and tighten. Stroke the valve several times to align the actuator and plug stem. With the plug stem off the seat, tighten the yoke bolts to finger tight.
  - 5.19.2 Loosen the stem clamp to finger tight. Using the appropriate installation instructions, adjust the plug stem position and tighten the stem clamp.
- 5.20 For one piece stem clamps:
  - 5.20.1 With the actuator lowered onto the valve, the plug stem and actuator stem should be touching. Before proceeding, verify the stem clamp is on the plug stem. The actuator must be rotated to screw the actuator stem onto the plug stem. Rotate the actuator down on the plug stem engaging the threads between the plug and actuator stem. Use wrenches on the flats provided on the plug stem and actuator stem to turn the actuator. Continue to turn the actuator on until the yoke contacts the bonnet.
  - 5.20.2 Lift the stem clamp into place and tighten to finger tight.

- 5.21 Once the actuator is on the valve, the plug stem engagement into the actuator stem must be adjusted. This adjustment is critical to shutoff and fail action.
- 5.22 Verify that the stem clamp is only finger tight. Verify that the yoke bolts are in place, but loosened to a ¼ to ½ inch gap.
- 5.23 Using air on the actuator, lift the plug off the seat and adjust the plug as needed. Stroke the plug down and watch for a gap where the yoke meets the bonnet. Continue to repeat this step until the plug contacts the seat and lifts the actuator, making a gap between the yoke where it contacts the bonnet of about ⅛".

**NOTE:** Rotating the plug while it is in contact with the seat will cause damage to both the plug and seat ring. Take care not to allow the plug to rotate while threading the actuator onto the plug stem.

- 5.24 Apply air to the actuator to lift the plug off the seat. Tighten the stem clamp and yoke bolts. Use Table IV to find torque values for the yoke bolts. Stroke fully open to fully closed several times to verify operation.

Table IV: Yoke Bolt Torque Values

Actuator Size	Spud Size	Connection Type	Bolt Size	Carbon Bolting (ft-lb)	Stainless Bolting (ft-lb)
100-200	3.38	Bolted Bonnet	0.62-11	44	33
100-200	4.00	Bolted/Half Ring	0.62-11	44	33
100-200	4.75	Bolted Bonnet	0.62-11	44	33
300-600	3.38	Bolted Bonnet	0.75-10	80	60
300-600	4.00	Bolted/Half Ring	0.75-10	80	60
300-600	4.75	Bolted Bonnet	0.75-10	80	60

- 5.25 For ATC, fail open, valves, remove the air from the actuator and allow the valve plug to backseat on the bonnet. This should put the plug at the top of the stroke. Using feeler gauges check to make sure that the upper spring button is not contacting the top of the spring-can. If the upper spring button is in contact with the top of the spring-can, the spring load is not being applied into the plug and will need to be adjusted.
- 5.26 Install the cover plate, cover plate O-ring, bolts and lock washers, using anti-seize compound.

## 6 Maintenance

At least once every six months, check for proper operation by following the preventative maintenance steps outlined below. These steps should not be performed while the actuator is in service. If an internal problem is suspected with the actuator, refer to the Disassembly and Assembly sections (Sections 4 and 5 respectively).

**⚠ WARNING:** To avoid serious injury, the following steps should only be performed with the air supply or positioner input disconnected.

- 6.1 When disconnecting air supply, observe actuator for correct fail-safe action.
- 6.2 Examine the actuator for damage caused by corrosive fumes and process drippings.
- 6.3 Clean the actuator and repaint any areas of severe oxidation.
- 6.4 If possible, stroke the actuator and check for smooth, full-stroke operation.

10

**⚠ WARNING:** To avoid serious injury, keep hands, hair and clothing away from all moving parts while operating the actuator.

## 7 Decommissioning the Spring-Can

- **DANGER:** The spring-can contains a pre-tensioned spring. The welds on the spring-can should not be removed until the spring has been determined to be relaxed. Serious injury or death can result from removing the welds while the spring is still compressed.

Spring-cans must be disassembled using specialized equipment. Before the weld seal is broken, the can must be contained inside of a press. It is recommended that the spring can be returned to Flowserve for decommissioning.

Table V: Spare Parts Kits

Actuator Size	Soft Goods	Stem Bushings*
100	232693.999.000	232698.999.000
150	232694.999.000	
200	232695.999.000	
300	232696.999.000	232699.999.000
400	232697.999.000	

\* Includes both actuator and piston stem bushings

Figure 1: Air-to-Open

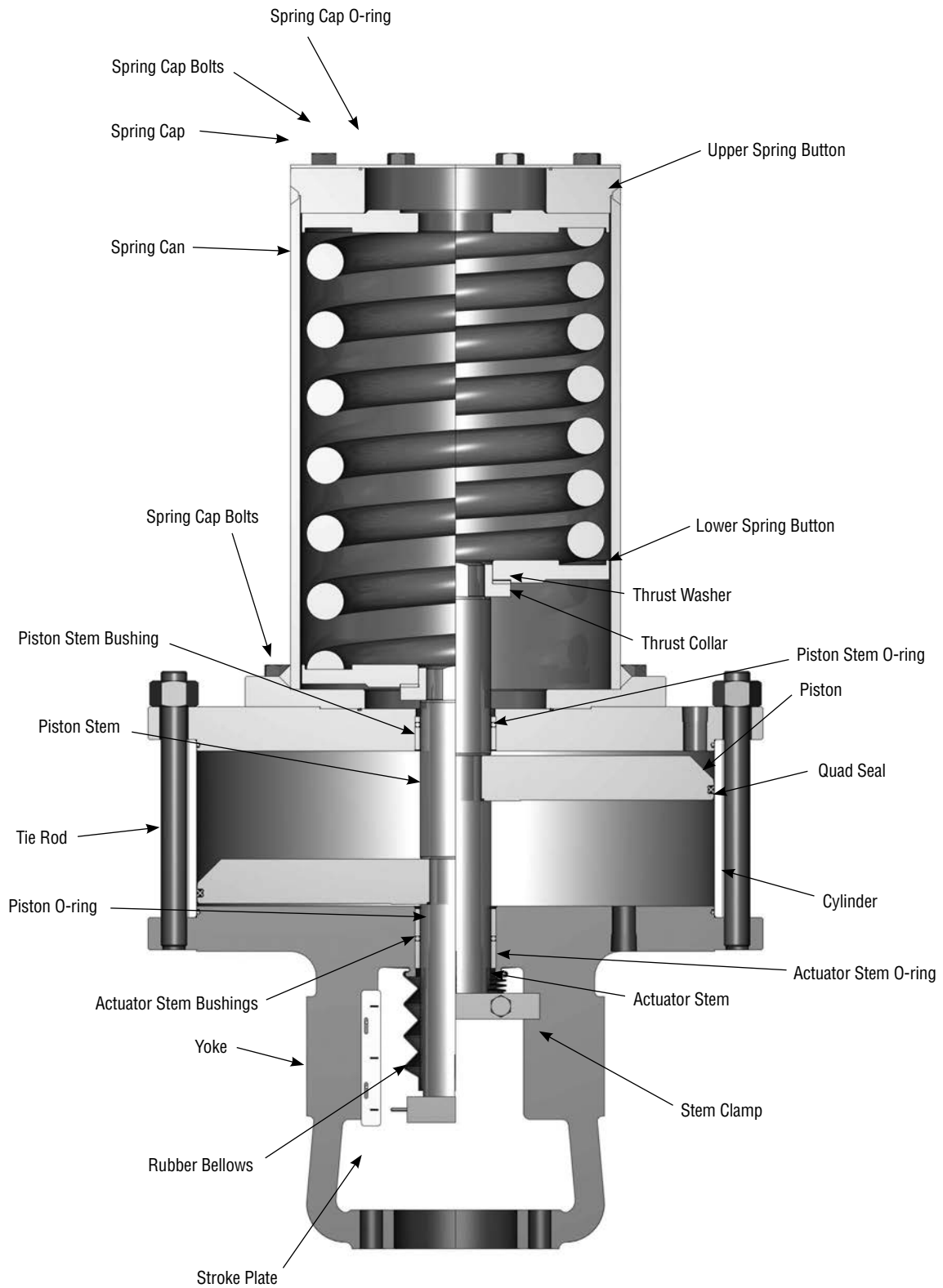

Figure 2: Air-to-Close

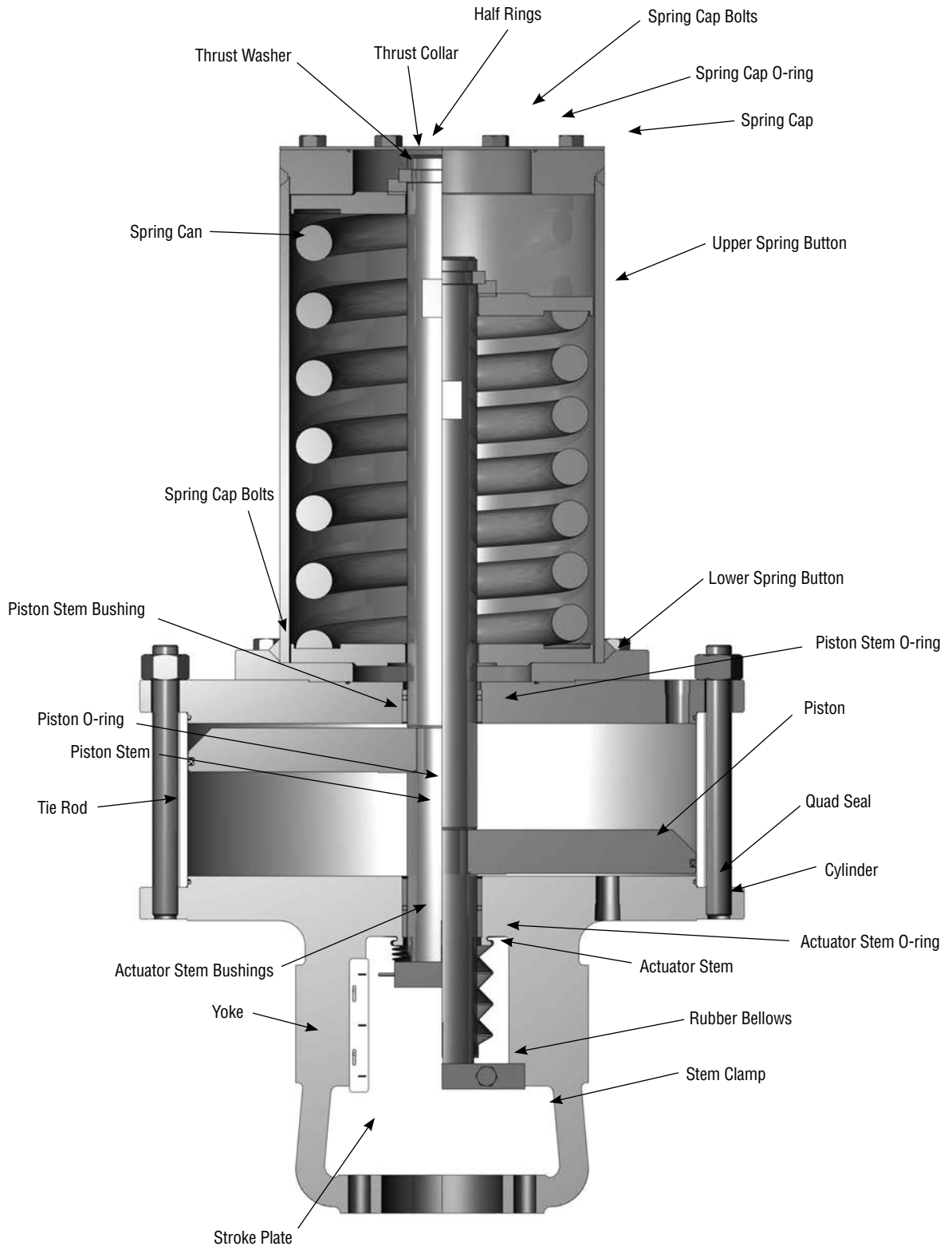

Figure 3: Exploded Drawing

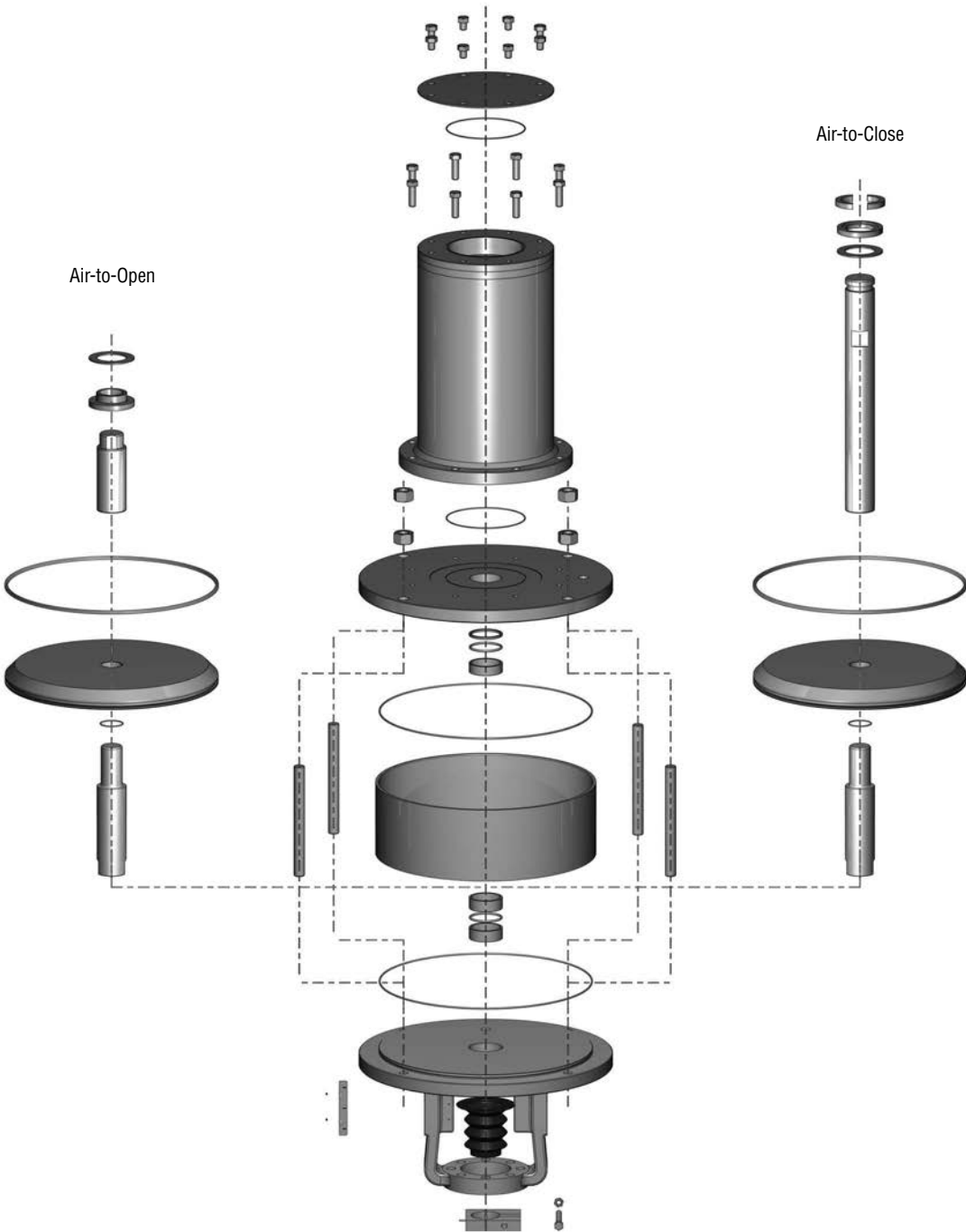
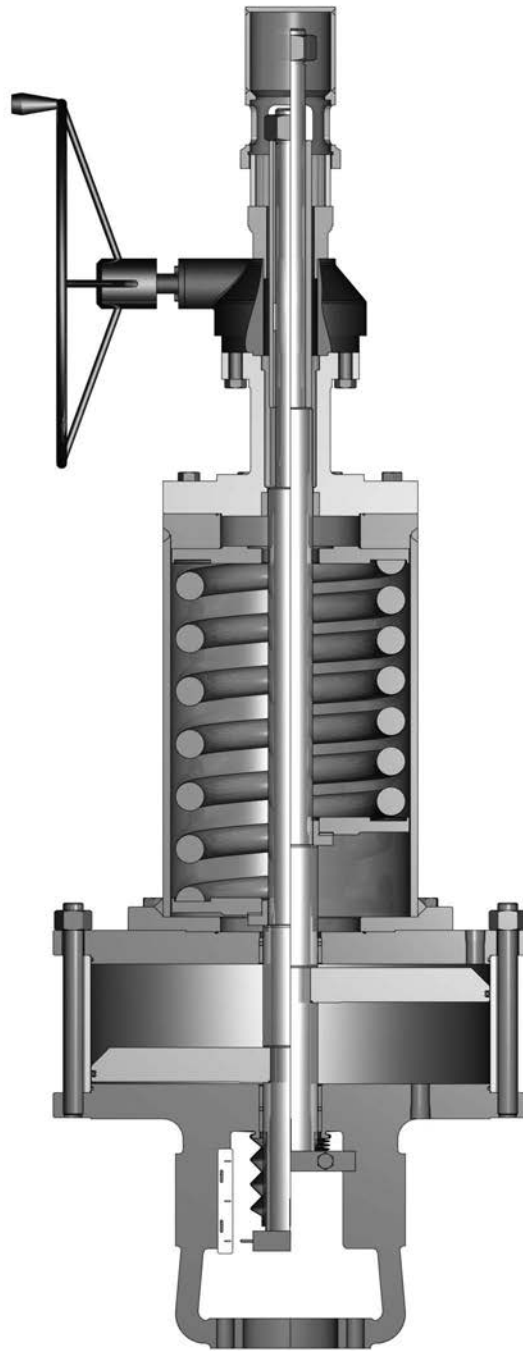

Figure 4: Optional Bevel Gear Operator Installation





**United States**  
Flowserve Corp.  
Flow Control  
Valtek Control Products  
1350 N. Mt. Springs Parkway  
Springville, UT 84663 USA  
Telephone: 1 801 489 8611  
Fax: 1 801 489 3719

FCD VLENIM0114-01 Printed in USA.

***To find your local Flowserve representative:***

For more information about Flowserve Corporation, visit  
[www.flowserve.com](http://www.flowserve.com) or call USA 1 800 225 6989

Flowserve Corporation has established industry leadership in the design and manufacture of its products. When properly selected, this Flowserve product is designed to perform its intended function safely during its useful life. However, the purchaser or user of Flowserve products should be aware that Flowserve products might be used in numerous applications under a wide variety of industrial service conditions. Although Flowserve can (and often does) provide general guidelines, it cannot provide specific data and warnings for all possible applications. The purchaser/user must therefore assume the ultimate responsibility for the proper sizing and selection, installation, operation, and maintenance of Flowserve products. The purchaser/user should read and understand the Installation Operation Maintenance (IOM) instructions included with the product, and train its employees and contractors in the safe use of Flowserve products in connection with the specific application.

While the information and specifications contained in this literature are believed to be accurate, they are supplied for informative purposes only and should not be considered certified or as a guarantee of satisfactory results by reliance thereon. Nothing contained herein is to be construed as a warranty or guarantee, express or implied, regarding any matter with respect to this product. Because Flowserve is continually improving and upgrading its product design, the specifications, dimensions and information contained herein are subject to change without notice. Should any question arise concerning these provisions, the purchaser/user should contact Flowserve Corporation at any one of its worldwide operations or offices.

© 2013 Flowserve Corporation, Irving, Texas, USA. Flowserve is a registered trademark of Flowserve Corporation.