



## ***Limitorque® B320 Series Bevel Gear Operators***

Rugged & dependable for manual or  
motorized valve control applications



***Experience In Motion***



## ***B320 bevel gear operators provide mechanical advantage for multi-turn actuation applications***

The Flowserve Limitorque B320 bevel gear operator not only makes it easy to manually operate multi-turn valves — it also makes it easy to convert to motorized service. Limitorque offers the B320 in an extended array of standard sizes and configurations to cover the widest range of applications, with the most common units are in stock for

immediate shipment. Limitorque also accommodates specialized needs with a variety of options, including handwheels, chainwheels, spur gears, and operating wrench nuts. Like every Limitorque product, the B320 is backed by Flowserve's worldwide service and parts supply network.

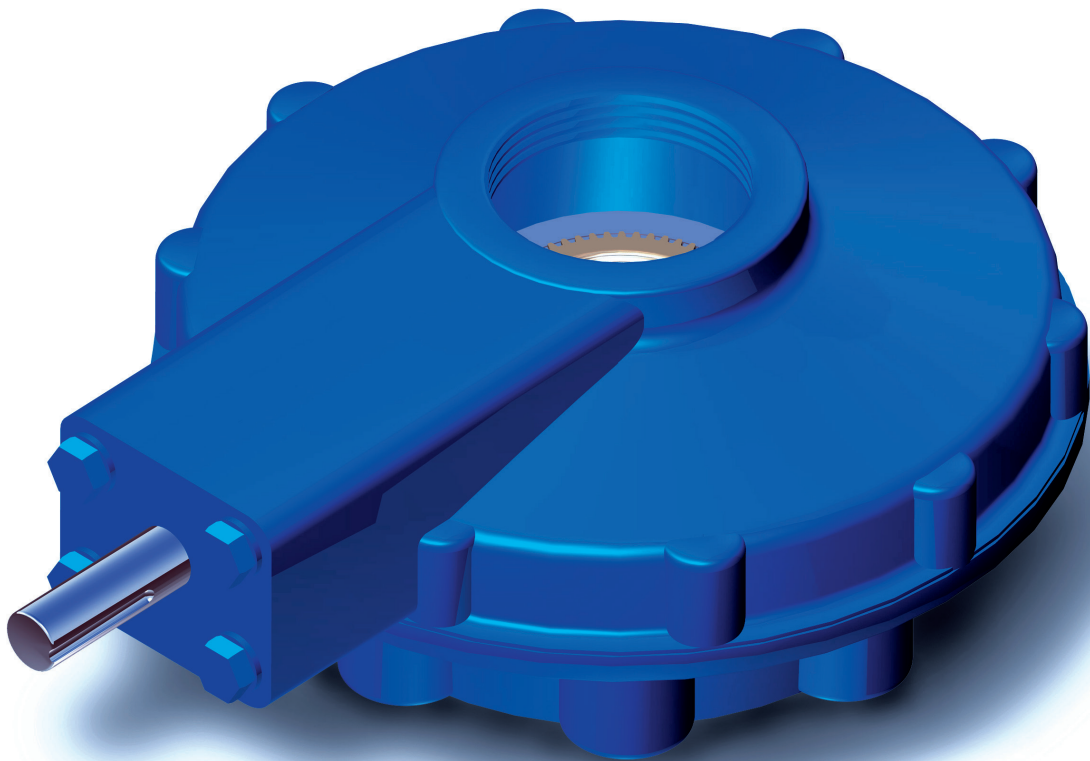

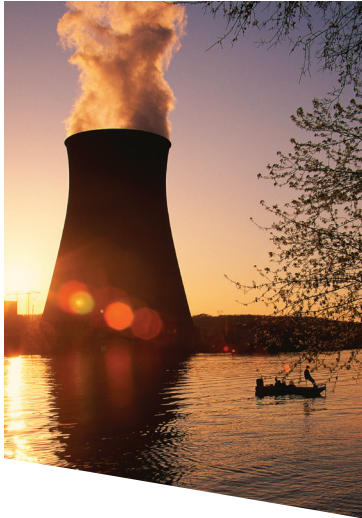

## ***B320 features: built for reliable valve control — whether manual or motorized***

The B320 offers torque ranges up to 8,000 ft-lb (10,856 N m) and thrust capacities to 325,000 lbs (1445 kN), for any application demanding a bevel gear operator with superior

strength and accuracy. It is most commonly used with sluice/slide gates, gate valves, and globe valves.

## ***Easily adaptable for other applications***

Flowserve Limatorque has designed the B320 to be configured to each customer's needs. Choose an optional handwheel for manual actuation. Add a spur gear attachment for greater mechanical advantage. And when manual operation simply

isn't practical, just couple the B320 with one of Limatorque's electric actuators for an economical, motorized, multi-turn package.

## ***Available options for the B320 operator include:***

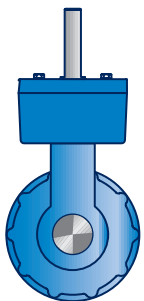

**Spur gear attachments for reduction of input torque**

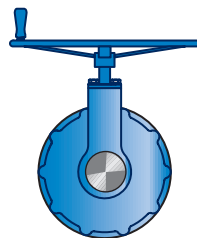

**Handwheels and chainwheels**

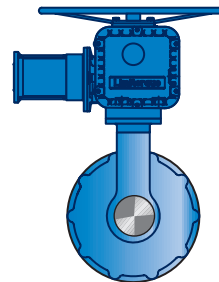

**Direct mounting to an electric valve actuator**

## ***Solid construction inside and out***

All B320 series operators are manufactured from the highest quality materials for maximum reliability. All gears are machined from high-strength alloy steel, ensuring smooth operation with minimum backlash. Input and output bevel gears — as well as the bevel pinion itself — are supported on low-friction roller bearings. Every B320 operator is permanently lubricated and fully waterproof to endure the harshest outdoor service. B320 series operators are suitable for weatherproof (NEMA 4) or temporary submergence service (NEMA 6, IP 67/68). All units are easily converted for motorized applications.

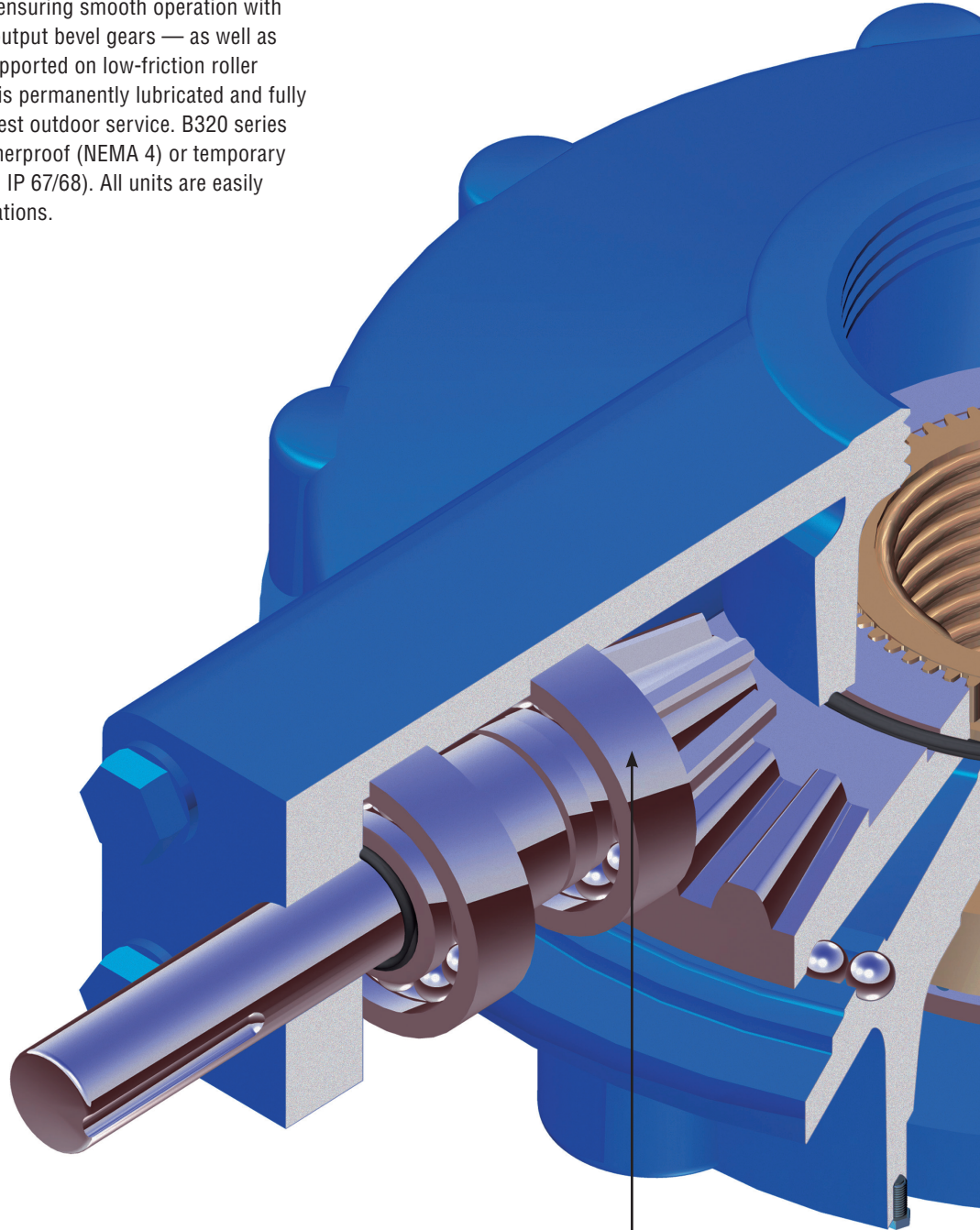

Bevel pinion and bevel gears are completely supported on anti-friction ball bearings.

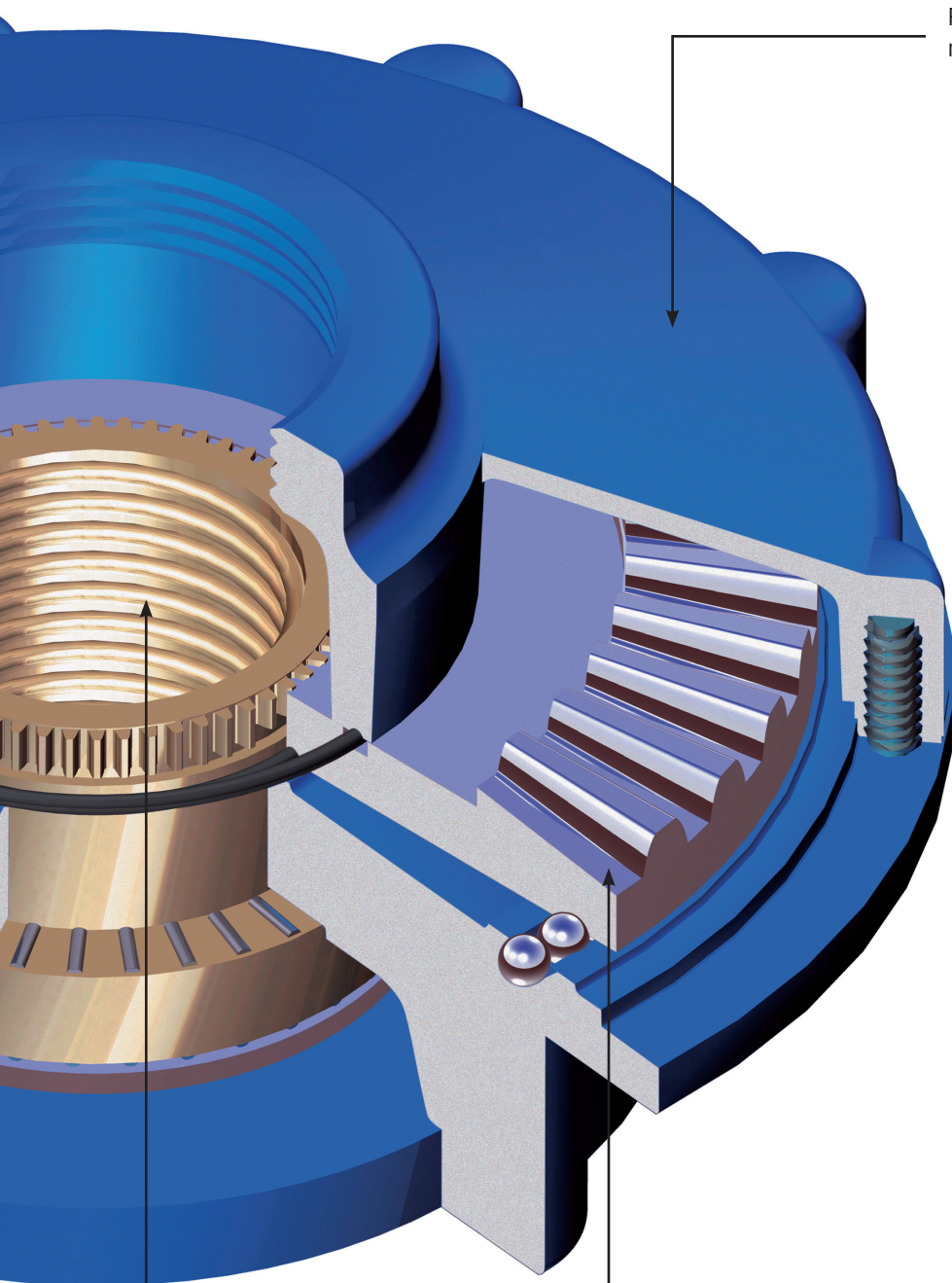

Rugged cast iron enclosure meets the most severe environmental conditions.

Splined bronze alloy stem nut is removable for threading or custom bore and key.

Machine-generated gearing assures minimum backlash and smooth operation.

# Physical Dimensions for B320 Series Bevel Gear Operator with MSS and ISO Mounting Base

## B320-20 through -80 Operators

## B320-90 operators

### Top view

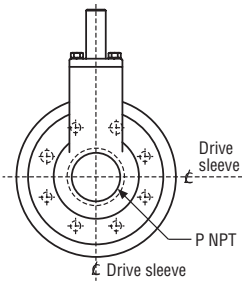

### Side view

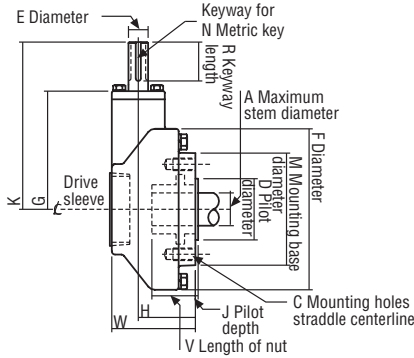

### Side view

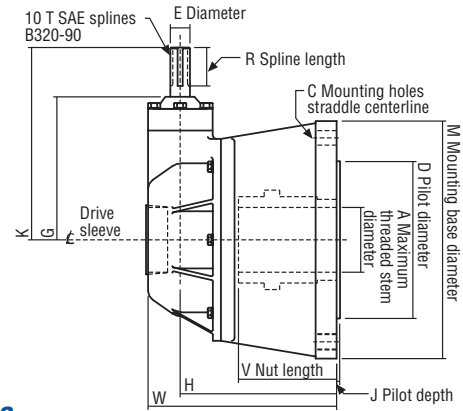

## B320 Series-20 through -90 bevel gear operator dimensions

MSS standard mounting configuration in inches

	Operator	A	C	D	E	F	G	H	J	K	M	N	P	R	V	W
	B320-20	2.36	(4) .625–11 x 1.38 DP, 5.500 BC (FA14)	3.750	0.982	7.6	5.6	3.6	.12	8.7	6.9	8 x 7	2.5	2.4	2.70	5.1
	B320-40	2.87	(4) .75–10 x 1.77 DP, 6.496 BC (FA16)	5.000	1.180	9.4	7.3	4.2	.12	10.4	8.3	8 x 7	3	2.4	3.29	5.8
	B320-50	3.54	(8) .625–11 x 1.38 DP, 10.000 BC (FA25)	6.000	1.378	14.0	9.1	5.0	.20	13.1	11.8	10 x 8	5	2.6	4.09	7.1
	B320-70	4.02	(8) .75–10 x 1.77 DP, 11.750 BC (FA30)	7.000	1.378	16.8	11.1	5.7	.20	15.1	13.8	10 x 8	5	2.6	4.76	7.8
	B320-80	5.12	(8) 1.25–7 x 2.76 DP, 14.000 BC (FA36)	8.500	1.769	19.7	13.4	6.5	.20	18.8	16.1	14 x 9	6	3.9	5.90	9.1
1p	B320-90	6.00	(8) 1.25–7 x 1.95 DP, 16.000 BC (FA40)	9.000	1.498	18.8	11.9	13.4	.375	15.68	18.8	10 T SAE spl.	6	2.3	8.00	16.4
2p <sup>1</sup>	B320-90	5.50	(8) 1.25–7 x 1.95 DP, 16.000 BC (FA40)	9.000	1.498	18.8	11.9	13.4	.375	15.68	18.8	10 T SAE spl.	6	2.3	8.00	16.4

ISO standard mounting configuration in millimeters

	Operator	A	C	D	E	F	G	H	J	K	M	N	P	R	V	W
	B320-20	60	(4) M16–2 x 35 DP, 140 BC (F14)	99.96	24.95	192	142	90.5	3	220	175	8 x 7	2.5	60	68.5	131
	B320-40	73	(4) M20–2.5 x 45 DP, 165 BC (F16)	129.96	29.95	240	185	106	3	263	210	8 x 7	3	60	83.5	147
	B320-50	90	(8) M16–2 x 35 DP, 254 BC (F25)	199.95	34.95	356	230	128	5	332	300	10 x 8	5	65	104	180
	B320-70	102	(8) M20–2.5 x 45 DP, 298 BC (F30)	229.95	34.95	426	282	145	5	384	350	10 x 8	5	65	121	198
	B320-80	130	(8) M30–3.5 x 70 DP, 356 BC (F35)	259.94	44.95	500	340	166	5	478	410	14 x 9	6	100	150	230
1p	B320-90	152	(8) M36–4 x 70 DP, 406 BC (F40)	300.00	38.05	–	302	340	7	398	478	10 T SAE spl.	6	57	203	416
2p <sup>1</sup>	B320-90	140	(8) M36–4 x 70 DP, 406 BC (F40)	300.00	38.05	–	302	340	7	398	478	10 T SAE spl.	6	57	203	416

Note 1: Two-piece drive sleeve standard. Optional one-piece drive sleeve available.

Note: • Dimensions for “P” are always shown in inches.

• Dimensions for “N” are always shown in millimeters.

• DP = deep; BC= bolt circle

## Physical Dimensions for B320 Series Bevel Gear Operator with 3:1 Spur Gear Attachment and MSS and ISO Mounting Bases

Front view

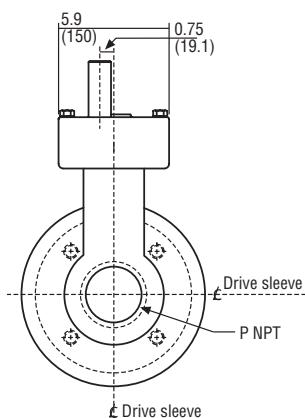

Side view

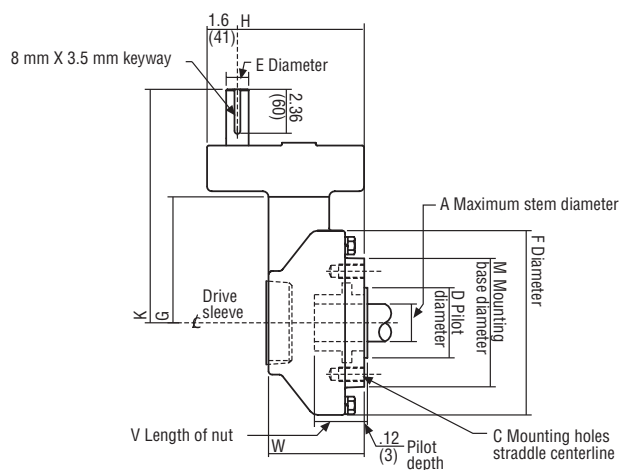

### B320-20 and -40 Series bevel gear operator with spur gear attachment dimensions

MSS standard mounting configuration in inches

Operator	A	C	D	E	F	G	H	K	M	P	V	W
B320-20	2.36	(4) .625-11 x 1.38 DP, 5.500 BC (FA14)	3.750	1.18	7.6	5.2	6.9	10.9	6.9	2.5	2.70	5.1
B320-40	2.87	(4) .75-10 x 1.77 DP, 6.496 BC (FA16)	5.000	1.180	9.4	6.9	7.5	12.6	8.3	3	3.29	5.8

ISO standard mounting configuration in millimeters

Operator	A	C	D	E	F	G	H	K	M	P	V	W
B320-20	60	(4) M16-2 x 35 DP, 140 BC (F14)	99.96	30	192	132	90.5	278	175	2.5	68.5	131
B320-40	73	(4) M20-2.5 x 45 DP, 165 BC (F16)	129.96	29.96	240	175	106	321	210	3	83.5	147

Note: • Dimensions for "P" are always shown in inches.

• DP = deep; BC= bolt circle

# Physical Dimensions for B320 Series Bevel Gear Operator with Spur Gear Attachment and MSS and ISO Mounting Bases

Front view

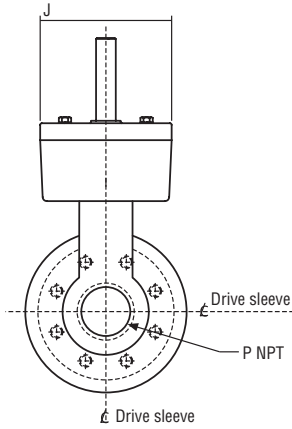

Side view

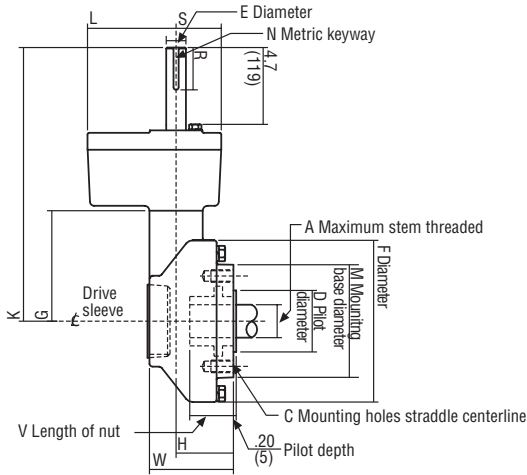

## B320-50 through -80 series bevel gear operator with spur gear attachment dimensions

MSS standard mounting configuration in inches

Operator	SGA Ratio	A	C	D	E	F	G	H	J	K	L	M	N	P	R	S	V	W
B320-50	10.8:1	3.54	(8) .625-11 x 1.38 DP, 10.000 BC (FA25)	6.000	1.180	14.0	9.1	5.0	6.1	18.6	5.4	11.8	8x3.5	5	2.6	2.8	4.09	7.1
B320-70	10.8:1	4.02	(8) .75-10 x 1.77 DP, 11.750 BC (FA30)	7.000	1.180	16.8	11.1	5.7	6.1	20.7	5.4	13.8	8x3.5	5	2.6	2.8	4.76	7.8
B320-80	10.8:1	5.12	(8) 1.25-7 x 2.76 DP, 14.000 BC (FA36)	8.500	1.180	19.7	13.4	6.5	7.9	23.8	7.2	16.1	8x3.5	6	3.9	3.9	5.90	9.1

ISO standard mounting configuration in millimeters

Operator	SGA Ratio	A	C	D	E	F	G	H	J	K	L	M	N	P	R	S	V	W
B320-50	10.8:1	90	(8) M16-2 x 35 DP, 254 BC (F25)	199.95	29.97	356	230	128	154	473	137	300	8x3.5	5	65	70	104	180
B320-70	10.8:1	102	(8) M20-2.5 x 45 DP, 298 BC (F30)	229.95	29.97	426	282	145	154	525	137	350	8x3.5	5	65	70	121	198
B320-80	10.8:1	130	(8) M30-3.5 x 70 DP, 356 BC (F35)	259.94	29.97	500	340	166	200	604	184	410	8x3.5	6	100	96	150	230

- Note:
- Dimensions for "P" are always shown in inches.
  - Dimensions for "N" are always shown in millimeters.
  - DP = deep; BC = bolt circle



## Physical Dimensions for B320 Series Bevel Gear Operator with 17.5:1 Spur Gear Attachment and MSS and ISO Mounting Bases

Front view

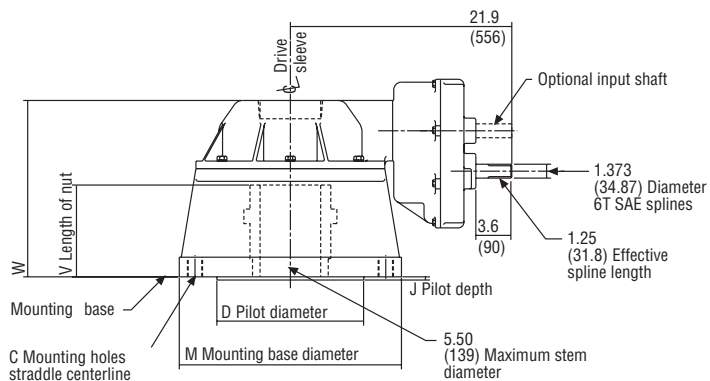

Side view

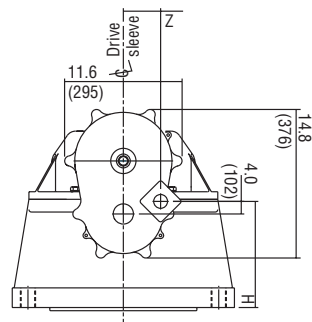

### B320-90 series bevel gear operator with spur gear attachment dimensions

MSS standard mounting configuration in inches

Operator	SGA Ratio	C	D	H	J	M	V	W	Z
B320-90	17.5:1	(8) 1.25-7 x 1.95 DP, 16.00 BC (FA40)	9.000 (+.000/-0.002)	17.4	.375	18.8	8.00	16.4	3.7

ISO standard mounting configuration in millimeters

Operator	SGA Ratio	C	D	H	J	M	V	W	Z
B320-90	17.5:1	(8) M36-4 x 70 DP, 406 BC (F40)	300 (+.00/-0.05)	442	7	475	203	416	94

Note: • Inch tap only available.

• DP = deep

\* BC = bolt circle

## General Specifications

Input torque can be calculated by dividing required output torque by ratio by efficiency.

Example: B320-20 at full manual rating

Input torque:  $750 / (3 \times 0.90) = 277 \text{ ft-lb}$

$1017 / (3 \times 0.90) = 376 \text{ N m}$

Operator	Operator Ratio	Operator Efficiency	Maximum Output Torque				Maximum Thrust		Stem Capacity		Attachment (SGA)	
			Manual		Motorized		lb	kN	in.	mm	Ratio	Eff.
			ft-lb	N m	ft-lb	N m						
B320-20	3:1 / 4:1	0.90	750	1017	600	813	40000	178	2.36	60	3:1	0.90
B320-40	4:1	0.90	1800	2443	1500	2035	80000	356	2.87	73	3:1	0.90
B320-40	6:1	0.90	1250	1696	1000	1357	80000	356	2.87	73	3:1	0.90
B320-50	4:1 / 6:1	0.90	3750	5088	3000	4071	100000	444	3.54	90	10.8:1	0.80
B320-70	6:1 / 8:1	0.90	6000	8142	4500	6106	150000	667	4.02	102	10.8:1	0.80
B320-80	6:1 / 8:1	0.90	8000	10856	6500	8820	200000	890	5.12	130	10.3:1	0.80
1p B320-90	6.2:1	0.90	8000	10856	8000	10856	325000	1446	6.00	152	17.5:1	0.80
2p <sup>1</sup> B320-90	6.2:1	0.90	8000	10856	8000	10856	325000	1446	5.50	140	17.5:1	0.80

Operator	HSG Cover Tap N.P.T.	Approximate Weights			
		lb		kg	
		Operator	With SGA	Operator	With SGA
B320-20	2.5	51	80	23	36
B320-40	3	68	97	31	44
B320-50	5	143	198	65	90
B320-70	5	254	309	115	140
B320-80	6	418	474	190	215
B320-90	6	745	875	339	398

Operator	Maximum Bore with Rectangular Key (Inches)	Maximum Bore with Square Key (Inches)	Maximum Bore with Metric Key
B320-20	2.00 Diameter with .5 x .375 Key	1.88 Diameter with .5 Key	50 mm with 14 x 9
B320-40	2.52 Diameter with .625 x .4375 Key	2.38 Diameter with .625 Key	64 mm with 18 x 11
B320-50	3.00 Diameter with .75 x .5 Key	2.88 Diameter with .75 Key	76 mm with 22 x 14
B320-70	3.70 Diameter with .875 x .625 Key	3.50 Diameter with .875 Key	94 mm with 25 x 14
B320-80	4.88 Diameter with 1.25 x .875 Key	4.50 Diameter with 1.00 Key	123 mm with 32 x 18
1p B320-90	5.50 Diameter with 1.25 x .875 Key	5.44 Diameter with 1.25 Key	140 mm with 36 x 20
2p <sup>1</sup> B320-90	5.00 Diameter with 1.25 x .875 Key	4.94 Diameter with 1.25 Key	130 mm with 32 x 18

Note 1: Two-piece drive sleeve standard. Optional one-piece drive sleeve available.

This page is left intentionally blank.



## Flowserve Corporation

### United States

Flowserve Limatorque  
5114 Woodall Road  
P.O. Box 11318  
Lynchburg, VA 24506-1318  
Phone: 434-528-4400  
Fax: 434-845-9736

### England

Flowserve Limatorque  
Euro House  
Abex Road  
Newbury  
Berkshire, RG14 5EY  
United Kingdom  
Phone: 44-1-635-46999  
Fax: 44-1-635-36034

### Singapore

Limatorque Asia, Pte., Ltd.  
12, Tuas Avenue 20  
Singapore 638824  
Phone: 65-6868-4628  
Fax: 65-6862-4940

### China

Limatorque Beijing, Pte., Ltd.  
RM A1/A2  
22/F, East Area, Hanwei Plaza  
No. 7 Guanghua Road, Chaoyang  
District  
Beijing 100004, Peoples Republic of  
China  
Phone: 86-10-5921-0606  
Fax: 86-10-6561-2702

### India

Flowserve Limatorque  
Plot No. #4, 1 A, Road No. 8, EPIP  
Whitefield, Bangalore – 560066  
Karnataka  
India  
Phone: 91-80-40146200  
Fax: 91-80-28410286

### Italy

Flowserve Limatorque  
Fluid Power Systems  
Via Rio Vallone 17  
20883 Mezzago MB  
Italy  
Phone: 39-039-620601  
Fax: 39-039-62060 213

FCD LMENBR3200-05-AQ Printed in USA. May 2015. © 2015 Flowserve Corporation

**To find your local Flowserve representative:**

visit [www.limatorque.com](http://www.limatorque.com) or call 1 434 528 4400