

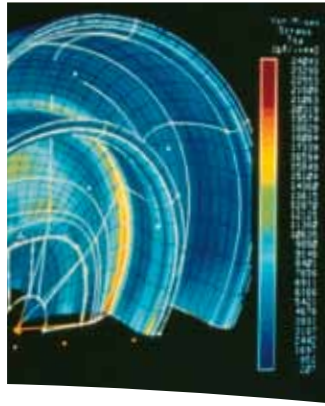

Nuclear Pump Upgrades WT and RLIJ



Experience In Motion



Pump Supplier To The World

Flowserve is the driving force in the global industrial pump marketplace. No other pump company in the world has the depth or breadth of expertise in the successful application of pre-engineered, engineered and special purpose pumps and systems.

Pumping Solutions

Flowserve is providing pumping solutions which permit customers to continuously improve productivity, profitability and pumping system reliability.

Market Focused Customer Support

Product and industry specialists develop effective proposals and solutions directed toward market and customer preferences. They offer technical advice and assistance throughout each stage of the product life cycle, beginning with the inquiry.

Dynamic Technologies

Flowserve is without peer in the development and application of pump technology, including:

- Hydraulic engineering
- Mechanical design
- Materials science
- Intelligent pumping
- Manufacturing technology

Broad Product Lines

Flowserve offers a wide range of complementary pump types, from pre-engineered process pumps, to highly engineered and special purpose pumps and systems. Pumps are built to recognized global standards and customer specifications.

Pump designs include:

- Single stage process
- Between bearing single stage
- Between bearing multistage
- Vertical
- Submersible motor
- Rotary
- Reciprocating
- Nuclear
- Specialty



Nuclear Pump Upgrades



The Nuclear Pump Leader

Flowserve has long maintained a leadership position in the nuclear industry. Its experience as a nuclear specialist dates to the birth of the nuclear industry. Today, Flowserve continues the tradition with pump and system upgrades that remain on the leading edge of technological advances in nuclear power.

Flowserve has developed numerous mechanical, metallurgical and hydraulic upgrades for the WT and RLIJ nuclear charge pumps. Through these proven upgrades, Flowserve can improve pump reliability, optimize hydraulic performance and reduce the total cost of ownership.

The goal of Flowserve is to share the responsibility for improved operational performance, lower equipment ownership costs and increase revenues for its customers. Flowserve engineers are available to review existing pump designs and maintenance histories. Upgrade recommendations will be based on feasibility and cost effectiveness.

Mechanical Design

Through its engineering expertise, Flowserve has developed numerous mechanical upgrade and retrofit options. Flowserve Pump Improvement Engineers diagnose the root causes of mechanical pump failure and recommend solutions to improve reliability and increase plant uptime.

- Robust rotor designs
- Mechanical seal upgrades
- 360° heavy-duty bearing housings
- Impeller and cover-to-cover interference fits

Materials Science

The proud heritage of Flowserve includes unsurpassed expertise in the development, processing and application of metallic and non-metallic materials. Flowserve materials engineers consult with customers to explore the application of new or improved materials to extend equipment life, improve performance and lower total ownership costs.

- Laser-hardening
- Cavitation resistant materials
- Superstraight™ pump shafts
- Diffusion alloying
- Non-metallic bearings
- Corrosion-resistant alloys

Hydraulic Engineering

Flowserve has extensive experience in implementing solutions that increase pump efficiency, lower NPSH requirements or adapt equipment operating performance. Flowserve can execute solutions that enhance performance, improve reliability and reduce operating costs.

- A-gap and B-gap modifications
- Biased wedge impellers
- Improved efficiency designs
- NPSH improvements

WT Upgrades

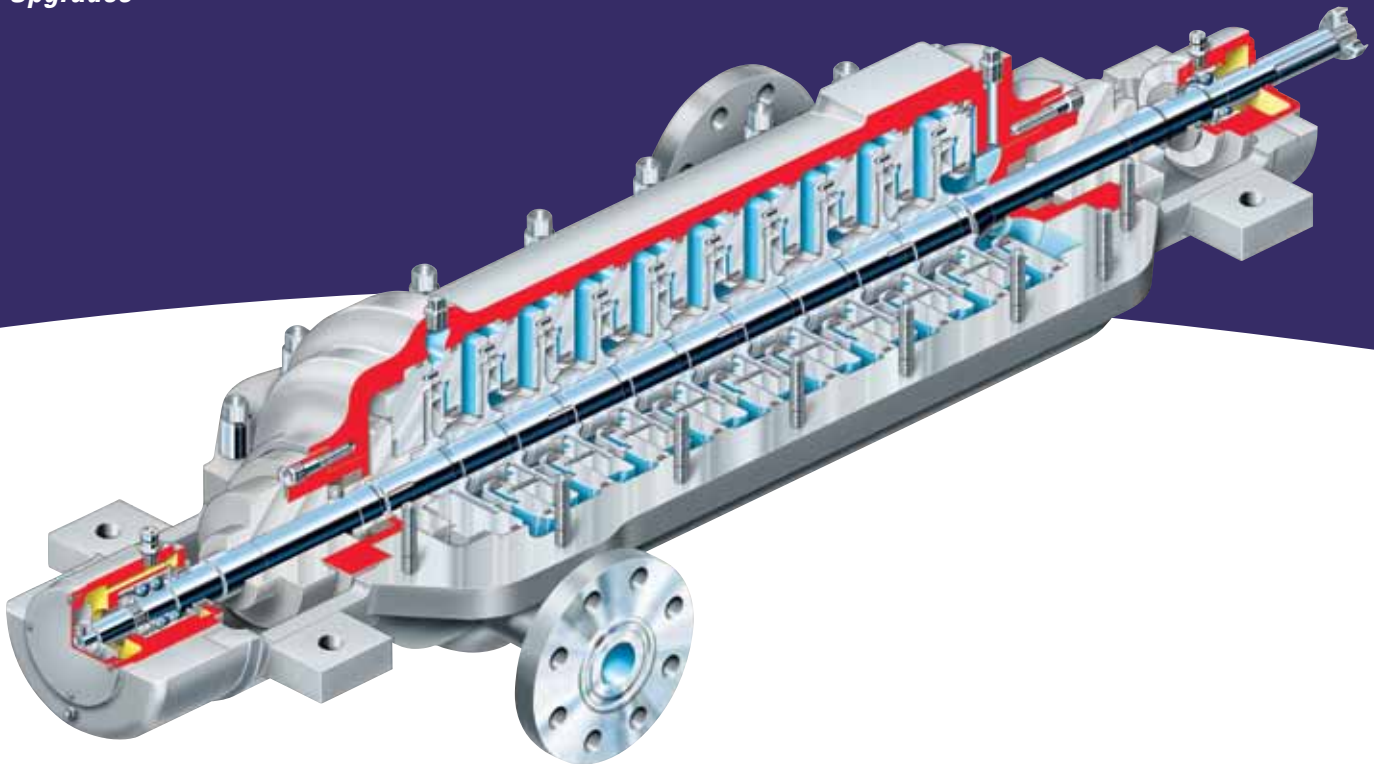

Flowserve engineers have developed several pre-engineered upgrades to prolong the useful life of WT pumps while simultaneously reducing the total cost of ownership. These upgrades make the pumps more tolerant of operating upsets, low flow operation, high speed operation and frequent starts and stops. The result is prolonged pump life, improved pump reliability and reduced pump maintenance costs.

Investment Cast Stainless Steel Impellers and Diffuser Return Channels

The precise dimensional and hydraulic passage uniformity of investment cast impellers and diffuser return channels results in:

- Optimized hydraulic efficiency
- Reduced power consumption

Furthermore, stainless steel offers improved toughness and increased resistance to corrosion and erosion.

Impeller Balancing

Impellers are dynamically balanced to stringent requirements to ensure hydraulic efficiency and to minimize vibration.

Vibration Reduction

Through dynamic impeller balancing and the use of Superstraight™ shaft material, vibration is virtually eliminated in the WT pump.

Available Stainless Steel Casing

WT casings are available in CA6NM stainless steel. This material exhibits increased strength and pressure integrity as well as improved resistance to corrosion and erosion. Furthermore, minor repair welds can be made without post weld heat treatment.

Horizontal Split Bolting

Horizontal split bolting allows for the increased bolt torque required to properly seat modern non-asbestos gaskets.

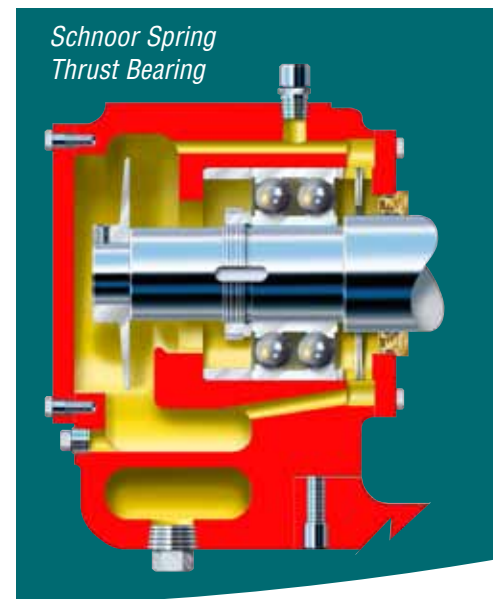
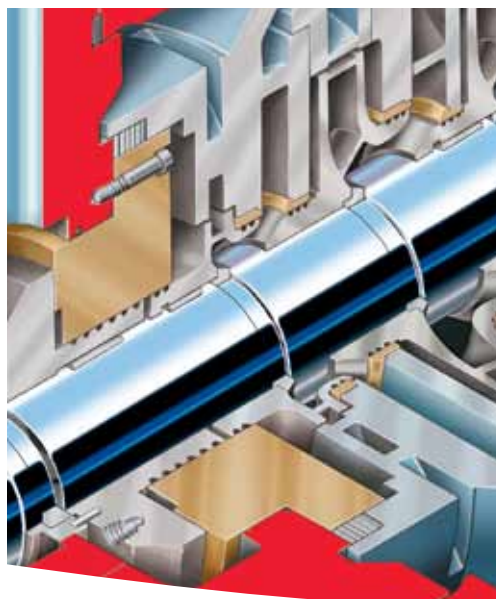

Laser Hardening Technologies

FlowsERVE offers two advanced laser treatments to create superior surface properties on critical parts. These treatments include:

- Laser hardening
- Direct laser deposition (DLD)

These processes are an effective means of improving component reliability and durability. The surfacing increases resistance to erosion, abrasion, galling and corrosion while maintaining critical clearances.

These treatments are often applied to:

- Impeller hubs
- Wear rings
- Bushings
- Balancing devices

Self-Compensating Balance Disc

Incorporating a laser hardened self-compensating balance disc (pictured top middle) will minimize unbalanced thrust and prolong bearing life. The self-compensating balance disc eliminates residual axial thrust on the thrust bearing and is able to handle a wide range of axial loads.

The disc is laser treated to a hardness in excess of 500 BHN to reduce wear and galling.

Split Ring Held Balance Disc

The WT balance drum is secured by a split ring and sleeve. This design replaces the threaded balance disc nut and eliminates broken or bent shafts.

Schnoor Spring Thrust Bearing

Fitting a Schnoor Spring to the thrust bearing helps to eliminate contact at the close running faces of the balance disc and balance sleeve during start-up and coast down. The result is reduced wear for prolonged bearing and pump life.

Superstraight™ Shaft Material

FlowsERVE Superstraight shafts provide trouble-free operation in vertical and horizontal pumps prone to undesirable shaft distortion. Applied to 410 martensitic stainless steel, the proprietary Superstraight heat treatment method inhibits distortion of shafts during operation. As a result, excess vibration is virtually eliminated and pump life is extended.



RLIJ Upgrades

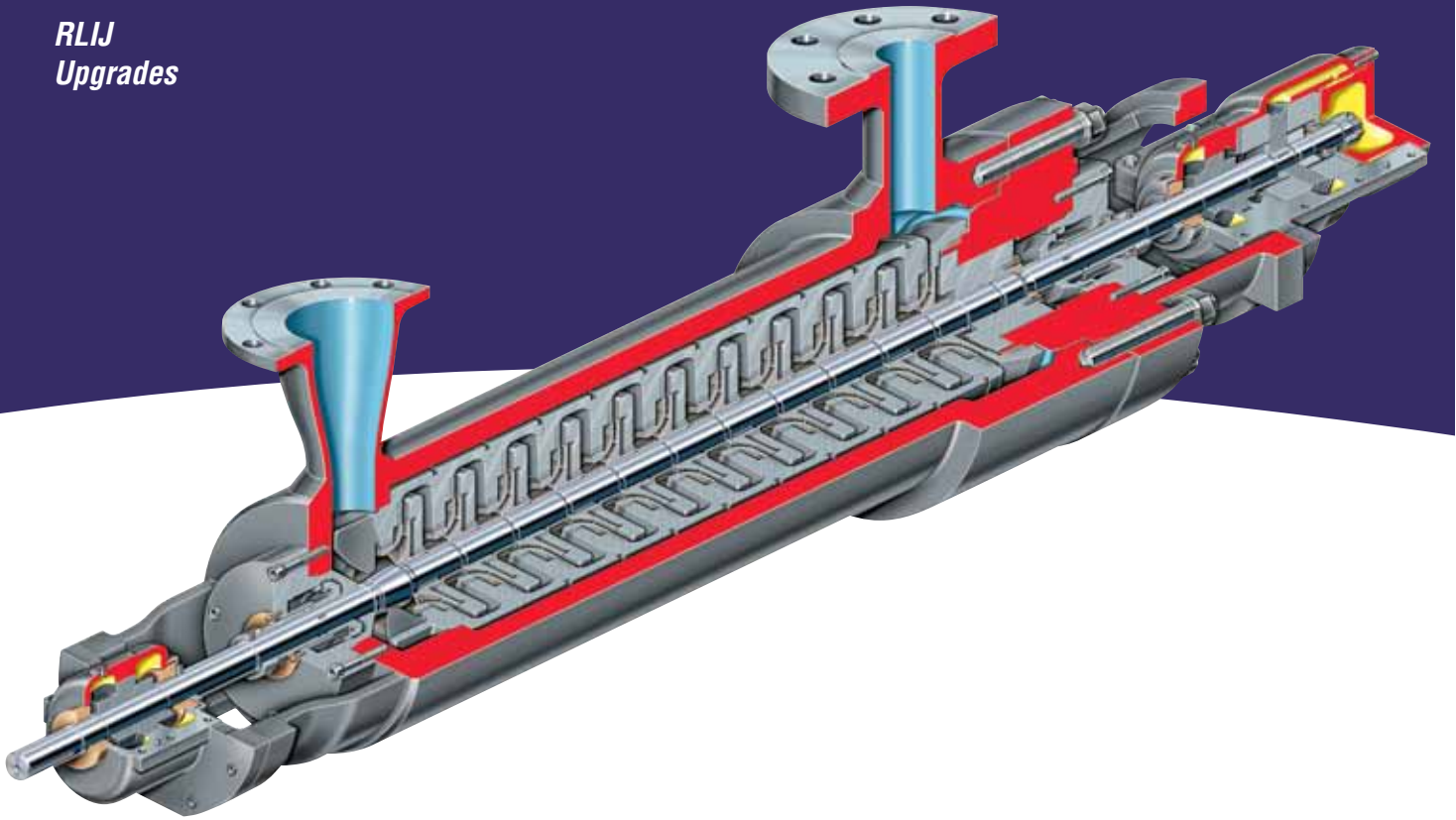

Flowserve has developed numerous upgrades to extend the useful life of RLII pumps while simultaneously reducing the total cost of ownership. These upgrades make the pumps more tolerant of operating upsets, low flow operation, high speed operation and frequent starts and stops. The result is prolonged pump life, improved pump reliability and reduced maintenance costs.

Impeller Interference Fits

The RLII can be upgraded with interference fit impellers. The resulting benefits are:

- Positive centralization in impeller diffuser flow passages
- Precision dynamic balance and repeatability

Investment Cast Impellers and Diffusers

The precise dimensional and hydraulic passage uniformity of investment cast impellers and diffusers result in:

- Optimized hydraulic efficiency
- Reduced power consumption

Furthermore, impeller and diffuser material upgrades provide improved toughness and increased resistance to corrosion and erosion.

Cover-to-Cover Interference Fits

Interference fit intermediate covers establish a tightly stacked bundle for ease of assembly. They also ensure that stationary running clearances remain in proper alignment with the rotor during operation.

- Precision radial alignment
- Positive axial centralization control

Shaft Material

High-strength CA625 shafting offers higher endurance limits, increased ductility and improved corrosion resistance. Moreover, new spherical radius retention grooves reduce shaft stresses.

Metal-to-Metal Discharge Head and Bearing Housing

A loose bearing housing can cause excessive vibration and premature wear. A metal-to-metal discharge head and bearing housing fit provides improved rigidity for enhanced rotor and stator internal alignment. Also includes:

- Tri-land bearings with cylindrical fit
- Stiffer 360° bearing bracket and drip pocket
- Six (6) bolt versus four (4) bolt bearing housing flange

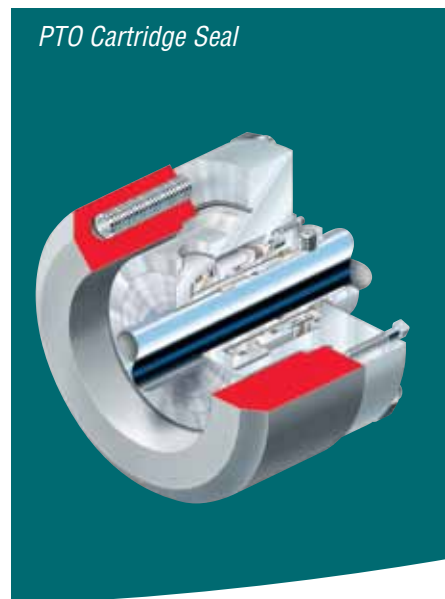
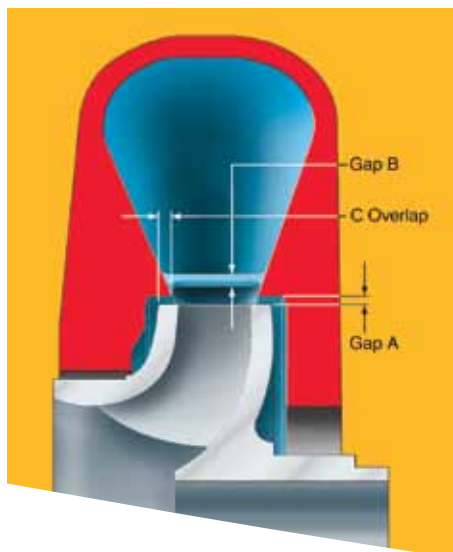

“A” Gap, “B” Gap, “C” Overlap Modifications

“A” Gap, “B” Gap, and “C” Overlap can be modified to current standards minimize low flow instability due to pressure pulsations and dynamic axial loads. Modifications are designed and tested to comply with narrow hydraulic performance band requirements. Benefits include:

- Reduced vibration and noise levels
- Longer bearing and seal life
- Reduced potential for volute or diffuser vane cavitation

Available Flanged Balance Drum

Incorporating a shrink-fit flanged balance drum will minimize unbalanced thrust and prolong bearing life.

- Self-compensating to eliminate residual axial thrust on the thrust bearing
- Handles wide range of axial loads
- Spring-loaded thrust bearing prevents wear during start-up and coast down

Laser Hardened Wear Surfaces

RLIJ impellers can be laser hardened to increase resistance to galling, wear and corrosion. The Laser Welded Surface Treatment (LWST) process deposits powdered metals without excessive heating of the base metal. Treated parts are not distorted and do not require additional heat treatment. The resulting application has a bond strength equal to the tensile strength of the base material.

Mechanical Seal Upgrade

The RLIIJ can be upgraded to the Flowsolve PTO cartridge seal for ease of installation and serviceability. This seal has an integral sleeve and pumping ring for enhanced self-aligning capabilities. Tungsten carbide versus carbon seal faces minimizes leakage and prolongs seal life. Internal recirculation eliminates coolers and external piping.

Additional Upgrades

- Instrumentation
 - Proximity probes: axial and radial
 - Remote monitoring
- Grooved wear rings
- Semi-circular split ring shaft retainers



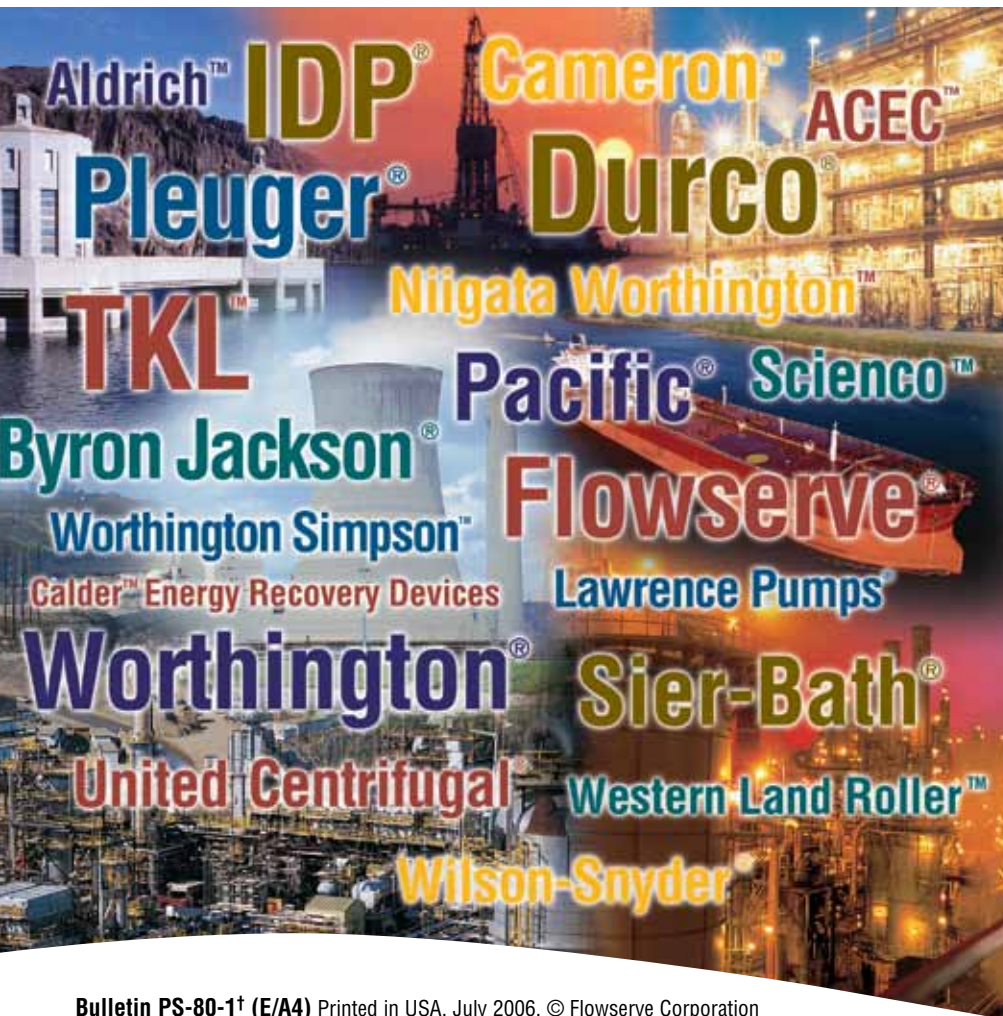

Bulletin PS-80-1† (E/A4) Printed in USA. July 2006. © Flowserve Corporation

To find your local Flowserve representative:

For more information about Flowserve Corporation,
visit www.flowserve.com or call USA 1 800 728 PUMP (7867)

USA and Canada

Flowserve Corporation
5215 North O'Connor Blvd.
Suite 2300
Irving, Texas 75039-5421 USA
Telephone: 1 972 443 6500
Telefax: 1 972 443 6800

Europe, Middle East, Africa

Flowserve Corporation
Via Rossini 90/92
20033 Desio (Milan), Italy
Telephone: 39 0362 6121
Telefax: 39 0362 303396

Latin America and Caribbean

Flowserve Corporation
6840 Wynnwood Lane
Houston, Texas 77008 USA
Telephone: 1 713 803 4434
Telefax: 1 713 803 4497

Asia Pacific

Flowserve Pte. Ltd.
200 Pandan Loop #06-03/04
Pantech 21
Singapore 128388
Telephone: 65 6775 3003
Telefax: 65 6779 4607