

**Manual No. 800-PC**  
**Issued: March 31, 2004**



**INSTRUCTION MANUAL**

**for**

**½" thru 2" 800 lb. Piston Lift Check Valves  
with Resilient Seat Option**

**Flowserve Corporation  
Flow Control Division  
1900 S. Saunders Street  
P.O. Box 1961  
Raleigh, NC 27603**

**Phone: (919) 832-0525  
FAX: (919) 831-3369**

## **Table of Contents**

1.0	Physical Description and Operation of Equipment
2.0	Design Conditions
3.0	Operating Conditions
4.0	Test Conditions
5.0	Operating Precautions and Limitations
6.0	Installation Instructions
7.0	Maintenance Requirements
8.0	Periodic Inservice Testing Recommendations and Procedures
9.0	Maintenance Instructions
10.0	Storage Requirements
11.0	Reference Drawings

Revision Sheet

<u>Revision</u>	<u>Date</u>	<u>Changes</u>
-	03/31/2004	Original Issue

## 1.0 **PHYSICAL DESCRIPTION AND OPERATION OF EQUIPMENT**

### 1.1 **Piston Check Valves (Figures 1 & 2 - See Section 11.0)**

Piston Lift Check valves are generally used in applications where pressure drop through the valve is not critical, although Flowserve piston check valves have a relatively low pressure drop.

These small piston lift check valves include a return spring to facilitate closing. All Flowserve piston check valves have body guided discs to provide resistance to wear, thus, insuring a longer life. An equalizing hole is provided in the disc as a drain for condensate in steam valves.

A dual seat may be supplied which provides a hard surface for high differential pressure sealing and a resilient seat for sealing during low differential pressure.

These instructions are being furnished to the customer for use in the installation, operation and maintenance of the 800 pressure class series piston lift check valves.

## 2.0 **DESIGN CONDITIONS**

N/A

## 3.0 **OPERATING CONDITIONS**

N/A

## 4.0 **TEST CONDITIONS**

4.1 Each valve covered by this manual has received the following hydrostatic tests:

4.1.1 Shell hydrostatic test at 1.5 times the 100°F pressure rating.

4.1.2 A seat leakage and disc closure test at 110% of the 100°F pressure rating.

#### 4.0 **TEST CONDITIONS** (Continued)

4.2 Each valve, supplied with resilient seated discs, received the following hydrostatic tests:

4.2.1 A low-pressure water seat test at 50 psig for containment isolation valves.

#### 5.0 **OPERATING PRECAUTIONS AND LIMITATIONS**

5.1 Maximum hydrostatic test pressure shall not exceed the values imposed by the ASME Code, Section III.

#### 6.0 **INSTALLATION INSTRUCTIONS**

##### 6.1 **Lifting and Handling Requirements and Limitations**

6.1.1 Good judgement should be exercised in selecting a lifting device that will safely support the unit's weight.

6.1.2 Remove the end covers.

6.1.3 Remove any blocks or heavy paper that might have been used to keep the disc from moving during shipment.

##### 6.2 **Installation**

6.2.1 Although the valves have been shipped in a clean condition, prior to installing the valves, examine the lines and the valve ports for foreign matter and clean them thoroughly if they have been exposed to the elements. (BEFORE CLEANING IN THIS FASHION, CHECK AT THE SITE TO SEE IF A SPECIFIC CLEANING PROCEDURE SHOULD BE FOLLOWED.) Flush the valves out with water if possible; otherwise blow them out with air or steam.

In performing this cleaning procedure, the ports should be vertical to assure complete removal of all matter which might have accumulated during storage.

6.2.2 Ensure that there is no line sag at the point of installation. Eliminate any pipeline deviation by the proper use of pipeline hangers or similar device.

## 6.2 **Installation** (Continued)

- 6.2.3 Extreme caution should be taken when installing check valves. The arrow on the valve body indicates flow direction. Therefore, when installing a check valve, place it so that the flow of the incoming fluid will open the valve and return flow will close it. Check valves installed in reverse position will stop the flow in the normal flow direction. Valves should be installed in a horizontal run of pipe with the gasket retainer on top. Maximum deviation from the horizontal should be  $\pm 15^\circ$ .
- 6.2.4 The valves should then be blocked or slung into position with apparatus that is sufficient to hold the valve assembly weight while the valve is being welded into the line. WELDING SHOULD TAKE PLACE WITH THE DISC IN THE OPEN POSITION. This is particularly important for valves with soft seats. Welding the valve with the disc closed will damage the resilient seat material. This may require removal of the internals prior to welding.
- 6.2.5 Remove the end protectors and clean the ends with a solvent such as acetone in preparation to welding.

## 7.0 **MAINTENANCE REQUIREMENTS**

### 7.1 **Preventative Maintenance**

- 7.1.1 Check all bolts periodically to ensure tightness and to forestall possible leaks.

### 7.2 **Recommended Spare Parts**

- 7.2.1 Recommended spare parts are pressure seal gasket (030), bonnet (002), disc assembly (004 & 005, 245 & 306 if equipped with resilient seated disc) and spring (429). The recommended quantity is 1 set for every 10 valves.
- 7.2.2 For consolidating spare parts (See 7.2.1), use the following guidelines:

- ½" thru 1" Piston Check Valves

Recommended spare parts are interchangeable throughout this size range. Note that similar materials should be ordered for valve body type (i.e. carbon steel bonnet for carbon steel valve).

## 7.0 MAINTENANCE REQUIREMENTS (Continued)

- 1½" and 2" Reduced Port Piston Check Valves

Recommended spare parts are interchangeable throughout this size range. Note that similar materials should be ordered for valve body type (i.e. carbon steel bonnet for carbon steel valve).

- 2" Full Port Piston Check Valves

Recommended spare parts are only interchangeable with other 2" Full Port Piston Check Valves. Same material restrictions stated above apply.

## 7.3 Lubrication

- 7.2.1 A light coating of lubricant should also be applied to the bonnet retainer threads if and when the valve is reassembled.

## 8.0 PERIODIC INSERVICE TESTING RECOMMENDATIONS AND PROCEDURES

- 8.1 This is not required for piston check valves without external operators.

## 9.0 MAINTENANCE INSTRUCTIONS

### 9.1 Disassembly

**WARNING**  
**PRIOR TO PERFORMING DISASSEMBLY,  
CLOSE OFF THE LINE PRESSURE TO  
THE VALVE, AND RELEASE ALL  
PRESSURE IN THE VALVE.**

- 9.1.1 Remove the anti-rotation pin (258) and the bonnet capscrew (216). The gasket retainer (033) may now be unscrewed and removed. Now thread the bonnet capscrew (216) directly into bonnet (002) and pull bonnet capscrew (216) directly upward.

Care should be taken to pull evenly and straight upward as not to score the neck walls of the valve and bonnet edges.

## 9.0 MAINTENANCE INSTRUCTIONS (Continued)

Pulling of the capscrew (216) will remove the bonnet (002) and pressure seal gasket (030). Lift out the spring (429) and disc (004).

It may be necessary to insert a wire hook into the holes located in the side of the disc in order to lift the disc out of the valve.

- 9.1.2 After removal of the disc from the valve, care should be taken to protect the seating surface from damage. The disc should be placed in a clean area until it is ready for replacement. THE SLIGHTEST NICK OR SCRATCH ON SEATING SURFACE MAY PREVENT COMPLETE SHUTOFF AND NECESSITATE EXTENSIVE REWORK OR REPLACEMENT.

### 9.1.3 Resilient Seat Removal (if so equipped)

To disassemble disc/resilient seat assembly:

- a) Remove retaining ring (245)
- b) Unscrew disc (004) from disc skirt (005)

Note: For removal, disc skirt should be held by the relieved outside diameter containing the drainage hole rather than by the outside diameter guiding surfaces. A slot for a fitted screw driver is provided at the top of the disc to facilitate removal and to prevent damage to these critical surfaces.

- c) Remove the resilient seat by carefully slipping it over the disc.

**CAUTION**  
**DO NOT EXPOSE THE RESILIENT SEAT TO ANY  
PETROLEUM BASED OILS OR GREASES OR OTHER  
CUTTING FLUIDS, LUBRICANTS, ETC. WHICH  
ARE HYDROCARBON BASED.**



## 9.0 **MAINTENANCE INSTRUCTIONS** (Continued)

### 9.2 **Refinishing Sealing Surfaces**

Minor discontinuities in the seat sealing surface, which may cause leakage can, in many cases, be removed by lapping. Major defects such as cracks or deep gouges will generally require replacement of the part.

Minor discontinuities on the valve disc sealing surfaces may be removed by remachining the surface to remove a few thousandths of material. Major defects will generally require replacement of the part.

(NOTE: Lapping is a polishing process where a sealing surface is ground with an abrasive held in place by a special fixture. The abrasive is commonly found in paste form or bonded to a paper backing. Detailed instructions on the use of lapping abrasives and fixtures, normally supplied with such equipment, should be adhered to.)

In order to maintain seat tightness in piston check valves, the sealing surfaces on both the disc and seat ring must be kept within close tolerances. Flowserve does not recommend lapping the disc directly to the seat. A good seal is dependent on line contact. Direct contact lapping will result in excessive seat widths.

Lapping equipment for the series 800 piston lift check valve seat is available through Flowserve. Contact your nearest Flowserve representative for information.

### 9.3 **Reassembly**

9.3.1 First, all dirt, scale and foreign matter should be removed from inside the valve body and bonnet.

9.3.2 Before reassembling the valve, check the seating surfaces to determine that no scratches or minor imperfections are on the disc or seat ring. If any are evident - lap these surfaces until none are visible. (Reference Para. 9.2)

## 9.0 **MAINTENANCE INSTRUCTIONS** (Continued)

### 9.3.3 **Resilient Seat Assembly** (if so equipped)

- a) Carefully place the resilient seat over the disc.
- b) Reassembly of the balance of the assembly is the reverse of that described in 9.1.3.
- c) Use nuclear grade thread lubricant on the threads, making sure that it does not come in contact with the resilient seat material.
- d) The disc skirt (005) is to be screwed firmly against the disc (004) shoulder prior to installing the retaining ring (245).

9.3.4 Reassembly of the valve is accomplished by inserting the disc or disc assembly (004) and spring (429), followed by the bonnet (002) and pressure seal gasket (030). Use a nuclear grade thread lubricant on the threads, making sure that it does not come in contact with the resilient seat material. Then screw in the gasket retainer (033). The bonnet capscrew (216) is then threaded into the bonnet through the hole in the retainer (033). A maximum of 5 ft-lbs of torque should be exerted on the bonnet capscrew. Insert the anti-rotation pin (258) in hole in top of the body (001).

NOTE: Consolidation of graphite during initial system pressurization is normal and will often cause the bonnet capscrew to become finger tight or even loose.

9.3.5 Retorque the bonnet capscrew to 50 to 60 inch-lbs. when the system is initially pressurized to ensure that the bonnets will not move out of the sealed position when the pressure is relieved.

## 9.4 **Trouble Shooting**

### A. **Leakage Between the Disc (004) and Seat Ring (013)**

This could be an indication that there is foreign matter on the seating surfaces.

Disassemble the valve and remove the source of the trouble. If no foreign matter is found, inspect the seating surfaces of the valve for signs of a scarred or damaged seat - in which case the seating surfaces of the Disc (004) and Seat Ring (013) should be lapped until no visible defects remain. (Refer to Para. 9.2)

## 10.0 **STORAGE REQUIREMENTS**

The valves have been shipped in the partially open position. Upon receipt of the valves at destination, the crates should be examined thoroughly for signs of mishandling or damage during shipment. With the valves strapped to the shipping skids, all bolting should be checked to ensure that the joints are secure. Bolting on occasion, may become loosened during shipment and handling.

The valves should then be stored in a sheltered area to protect them from the elements, dirt and foreign material. They should not be exposed to the atmosphere, uncrated or removed from the shipping skids except in a clean area just prior to installation.

If the valves are not to be installed within a short period of time after receipt, and will require long-term storage, the following should be adhered to:

- (a) They should be stored in an upright position and where there is minimal temperature variations and the temperature does not drop below 50°F.
- (b) In their storage condition, the valves should be wrapped in polyethylene to prevent accumulation of dust or foreign matter.
- (c) A check-off tag should be affixed to each unit and should be dated and signed off by the inspector witnessing the inspection which is recommended at 6-month intervals.

The shelf life for resilient seat materials is 5 years.

The shelf life for gaskets is indefinite.

**SECTION 11.0**

**REFERENCE DRAWINGS**

FIGURE 1

PISTON CHECK VALVE WITH  
HARD SEATED DISC

PART NO	QTY	DESCRIPTION
001	1	BODY
002	1	BONNET
004	1	DISC
013	1	SEAT RING
030	1	PRESSURE SEAL GASKET
032	1	SPACER RING
034	1	BONNET RETAINER
216	1	BONNET CAPSCREW
258	1	ANTI-ROTATION PIN
260	1	WIRE
345	1	NAMEPLATE
346	1	IDENTIFICATION PLATE
429	1	SPRING

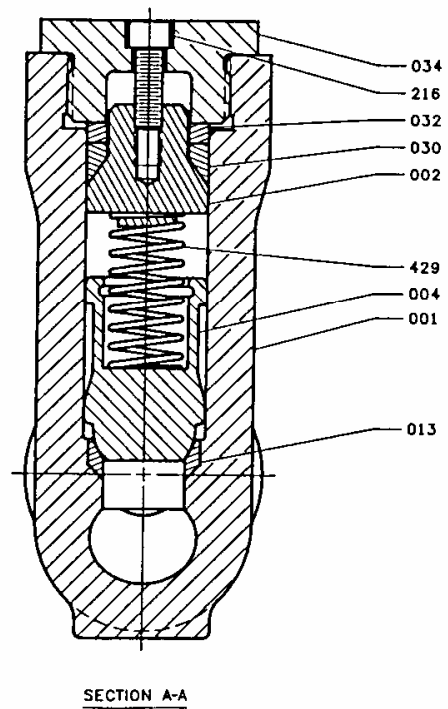
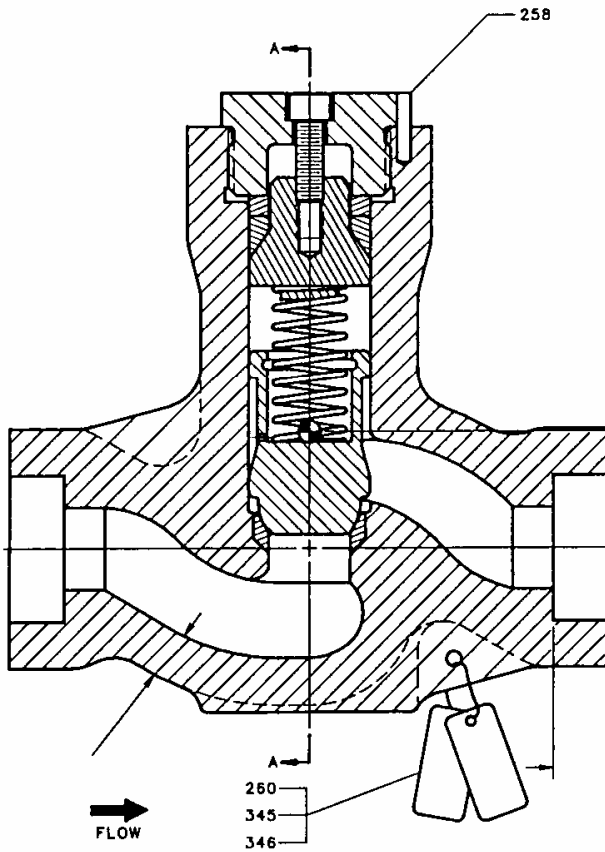
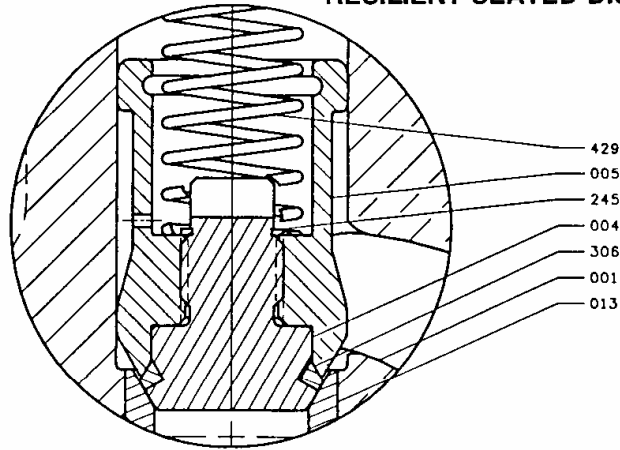

FIGURE 2

PISTON CHECK VALVE WITH  
RESILIENT SEATED DISC



ENLARGED DETAIL B

PART NO	QTY	DESCRIPTION
001	1	BODY
002	1	BONNET
004	1	DISC
005	1	DISC SKIRT
013	1	SEAT RING
030	1	PRESSURE SEAL GASKET
032	1	SPACER RING
034	1	BONNET RETAINER
216	1	BONNET CAPSCREW
245	1	RETAINING RING
258	1	ANTI-ROTATION PIN
260	1	WIRE
306	1	RESILIENT SEAT
345	1	NAMEPLATE
346	1	IDENTIFICATION PLATE
429	1	SPRING

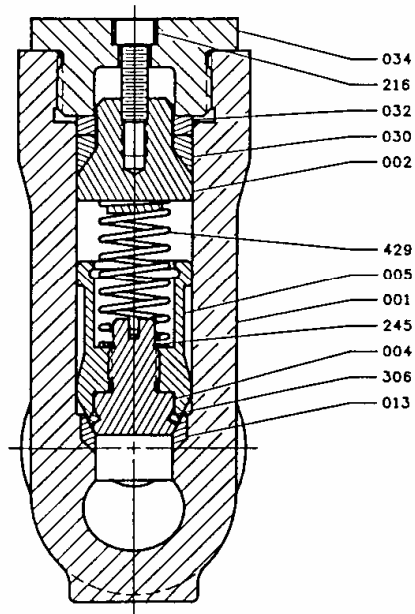
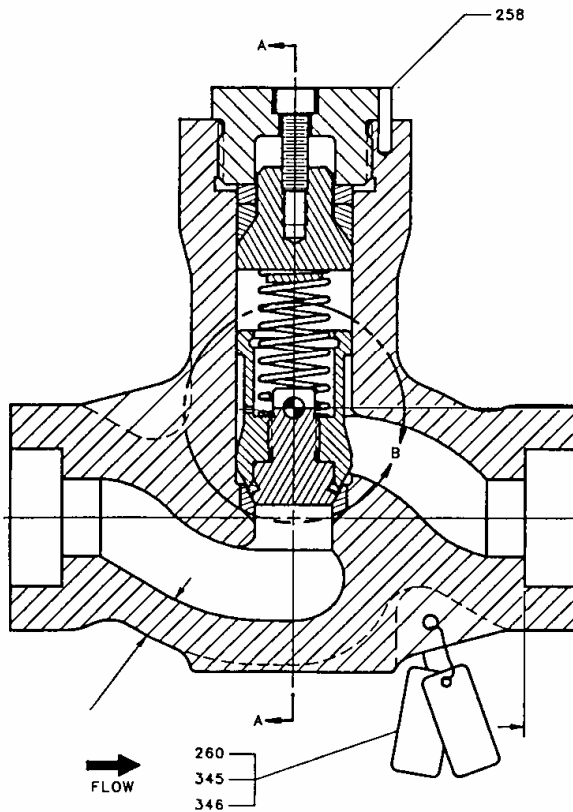

SECTION A-A