

MX-85/140 Actuator

FCD LMAIM1341-00

Maintenance and Spare Parts

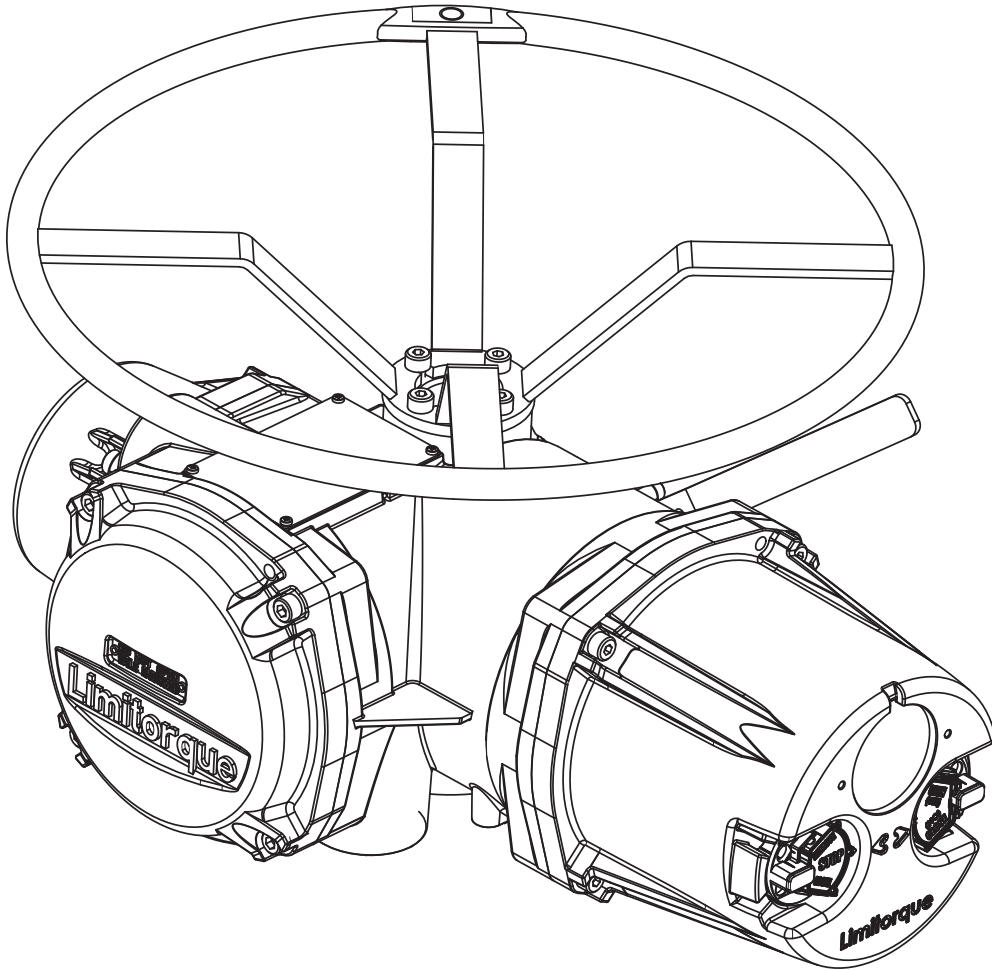

FLOWSERVE

Limitorque Actuation Systems

Contents

1	Introduction	1
1.1	Premise	1
1.2	Important Notes & Warning Statements	1
1.3	Procedure Emphasis	2
1.4	Reference Documents	2

2	Accutronix MX Actuator Subassembly	3
2.1	MX Actuator Subassembly Components	4
2.2	Product Information	4
2.2.1	Product Description	4
2.2.2	Storage	4
2.2.3	Unit Weights	5
2.3	Product Identification	5
2.3.1	Initial Inspection and Recording Suggestions	5
2.4	Maintenance	5
2.4.1	Recommended Maintenance	5
2.4.2	Unit Lubrication	6
2.4.3	O-rings and Lubrication	7
2.5	Subassembly Removal and Remounting Procedures	7
2.6	How to Order Replacement Subassemblies	7
2.6.1	Replacement Parts	7
2.6.2	Return Procedure	7

3	Remove Actuator from Mounting Adapter	9
3.1	Actuator Removal with Type B1/B4/B4E Base (Torque)	9
3.1.1	Removal (Type B1/B4/B4E Base)	9
3.1.2	Remounting (Type B1/B4/B4E Base)	10
3.2	Actuator Removal with Type A1/A1E Base (Thrust)	11
3.2.1	Removal (Type A1/A1E Base)— Actuator removal separate from thrust base	11
3.2.2	Remounting (Type A1/A1E Base)— Actuator remounting separate from thrust base	13
3.2.3	Removal (Type A1/A1E Base)— Actuator and thrust base as a unit	14
3.2.4	Remounting (Type A1/A1E Base)— Actuator and thrust base as a unit	15

4 Mechanical Assemblies 17

4.1	Motor	17
4.1.1	Removal	18
4.1.2	Remounting	19
4.2	Declutch	21
4.2.1	Removal	22
4.2.2	Remounting	23
4.3	Side-Mounted Handwheel with Spur Gear Attachment	25
4.3.1	Removal of Handwheel	26
4.3.2	Removal	26
4.3.3	Remounting	28
4.4	Thrust Base Type A1/A1E	31
4.4.1	Removal	33
4.4.2	Remounting	33
4.5	Baseplate Type B4	34
4.5.1	Removal	35
4.5.2	Remounting	36
4.6	Worm Shaft	36
4.6.1	Removal	37
4.6.2	Remounting	37
4.7	Drive Sleeve	39
4.7.1	Removal	40
4.7.2	Remounting	41
4.7.3	Optional Drive Sleeve and Baseplate Removal	42
4.7.4	Optional Drive Sleeve and Baseplate Remounting	44
4.8	Handwheel Worm Gear	46
4.8.1	Removal	46
4.8.2	Remounting	48
4.9	Clutch and Clutch Ring Components	50
4.9.1	Removal	51
4.9.2	Remounting	52

5 Electronic Assemblies 55

5.1	Accutronix Control Panel (ACP)	55
5.2	Installation and Removal of SMT Controls	56
5.2.1	Installation	56
5.2.2	Removal	59
5.2.3	Fuse Replacement	60
5.2.4	Control Module Return Options	60
5.3	Adding Electronic Options to Your Accutronix MX Actuator	60
5.4	Restoring Power to Actuator with New Control Module	61
5.5	Terminal Block	62
5.5.1	Removal	62
5.5.2	Remounting	65
5.6	Control Module—Contactor Assembly	67
5.6.1	Removal	68
5.6.2	Remounting	69
5.7	Encoder	71
5.7.1	Removal	72

5.7.2	Remounting	73
5.8	Encoder Drive Cartridge	74
5.8.1	Removal	75
5.8.2	Remounting	75
5.9	Motor Lead Harness	76
5.9.1	Removal	76
5.9.2	Remounting	77

6 Spare and Replacement Parts 79

6.1	Guidelines for Recommended Spare Parts	79
6.1.1	Wear Components	79
6.1.2	Bearings, O-rings and Seals	79
6.1.3	Critical Components	80
6.2	Recommended Spare Parts for MX Actuators	80
6.2.1	Commissioning and Startup	80
6.2.2	Short-Term Duty	80
6.2.3	Long-Term Duty	80
6.2.4	Severe Duty	81
6.3	Other Concerns	81

7 Regulatory Information 83

7.1	Declaration of Conformity	83
-----	---------------------------	----

Figures

Figure 2.1 – Accutronix MX Actuator	3
Figure 2.2 – Accutronix MX Nameplate	5
Figure 2.3 – Oil Fill/Plug Locations	6
Figure 4.1 – Motor	17
Figure 4.2 – Declutch	21
Figure 4.3 – Side-Mounted Handwheel With SGA	25
Figure 4.4 – Type A1 Thrust Base – F25 Flange	31
Figure 4.5 – Type A1 Thrust Base (MX-85) - F16 Flange	32
Figure 4.6 – Type B4 Baseplate	34
Figure 4.7 – 10:1 and 13:1 ratio	39
Figure 4.8 – Handwheel Worm Gear Assembly	46
Figure 4.9 – Clutch and Clutch Ring Components	50
Figure 4.10 – Clutch Ring	52
Figure 5.1 – Accutronix Control Panel	55
Figure 5.2 – Location of Fuses and Voltage Jumper	60
Figure 5.3 – Restoring Power to Actuator with New Control Module	61
Figure 5.4 – Terminal Block	62
Figure 5.5 – Control Module – Contactor Assembly	67
Figure 5.6 – Control Module – Contactor Assembly Wiring Diagram	67
Figure 5.7 – Encoder	71
Figure 5.8 – Encoder Drive Cartridge	74
Figure 5.9 – Motor Lead Assembly	76

Tables

Table 2.1 – MX Actuator Subassembly Components	4
Table 2.2 – Unit weights	5
Table 2.3 – MX-85 and 140 Oil Capacities when using Oil Fill/Plug Ports	6
Table 4.1 – Motor Parts List	17
Table 4.2 – Declutch Parts List	21
Table 4.3 – Side-Mounted Handwheel Parts List	25
Table 4.4 – Type A1 Thrust Base Parts List	31
Table 4.5 – Type A1 Thrust Base Parts List (MX-85)	32
Table 4.6 – Type B4 Baseplate Parts List	34
Table 4.7 – Worm Shaft Parts List	36
Table 4.8 – Drive Sleeve Parts List	39
Table 4.9 – Handwheel Worm Gear Assembly Parts List	46
Table 4.10 – Clutch and Clutch Ring Components Parts List	50
Table 4.11 – Clutch Ring Assembly Parts List	52
Table 5.1 – Accutronix Control Panel Parts List	55
Table 5.2 – Terminal Block Parts List	62
Table 5.3 – Control Module—Contactor Assembly Parts List	67
Table 5.4 – Encoder Parts List	71
Table 5.5 – Encoder Drive Sleeve Speed (rpm)	72
Table 5.6 – Encoder Drive Cartridge Parts List	74
Table 5.7 – Encoder Drive Cartridge Drive Sleeve Speed	74

1 Introduction

1.1 Premise

The MX actuator components are separated into subassembly groupings. This manual covers the Removal and Re-mounting procedures for each subassembly group. Use these instructions when disassembly is required for servicing, maintenance, or parts replacement.

1.2 Important Notes and Warning Statements

Please read this Maintenance & Spare Parts Manual carefully and completely before attempting to store or perform maintenance on your Limitorque valve actuator. Further installation, setup, and operation instructions are available in the Installation & Operation manual (LMAIM1306) located in the actuator terminal compartment at shipment.

- ⚠ **WARNING:** Be aware of electrical hazards within the actuator and high-pressure hazards of the attached valve or other actuated device when installing or performing maintenance on your MX actuator. Failure to observe these pre-cautions could result in serious bodily injury, damage to the equipment, or operational difficulty.
- ⚠ **WARNING:** Do not manually operate actuator with devices other than installed handwheel and declutch lever. Using additive force devices (cheater bars, wheel wrenches, pipe wrenches, or other devices of this nature) on the actuator handwheel or declutch lever may cause serious per-son-al injury and/or damage to the actuator or valve.

1.3 Procedure Emphasis

Please refer to the following methods used to emphasize text throughout this manual. Safety warnings, cautions, and notes present material that is important to user-safety. Be sure to read any safety notices you see as they could prevent equipment damage, personal injury, or even death to you or a co-worker.

Safety notices are presented in this manual in three forms:

☠ **WARNING:** Refers to personal safety. Alerts the user to potential danger. Failure to follow warning notices could result in personal injury or death.

⚠ **CAUTION:** Directs the user's attention to general precautions that, if not followed, could result in personal injury and/or equipment damage.

NOTE: Highlights information critical to the user's understanding of the procedure.

1.4 Reference Documents

- Accutronix Protection, Control & Monitoring features of MX Electric Actuators (LMABR1300)
- Accutronix MX Control, Performance & Value in Multi-turn Electric Valve Actuators (LMABR1302)
- Accutronix MX Installation Manual (Bulletin LM AIM1306)

The latest revisions to these documents are available on-line from Limitorque's web site, www.limitorque.com.

2

Accutronix MX Actuator Subassembly

Figure 2.1 – Accutronix MX Actuator

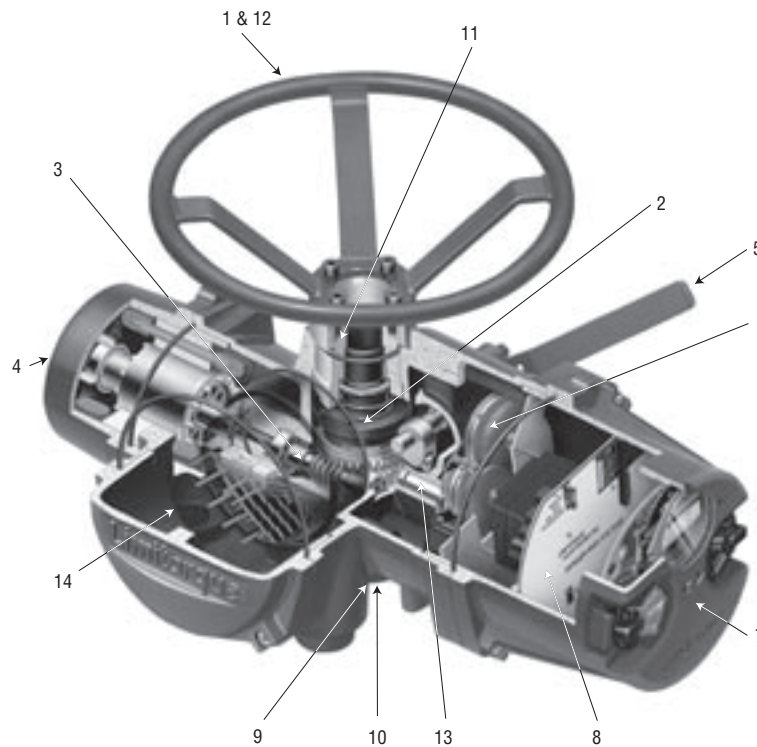

2.1 MX Actuator Subassembly Components

Table 2.1 – MX Actuator Subassembly Components

No.	Description
1	Top-mounted handwheel
2	Drive sleeve
3	Worm shaft
4	Motor
5	Declutch Lever
6	Encoder
7	Accutronix Control Panel (ACP)
8	Control module
9	Optional bases Thrust Base type: • A1 = Standard thrust base • A1E = Extended-reach thrust base
10	Baseplate-type B4 with stem nut options type: • B4 = stem nut with variable bore and key • B4E = extended-reach stem nut with variable bore and key
11	Handwheel worm gear
12	Side-mounted handwheel (not shown)
13	Encoder drive cartridge
14	Terminal block

2.2 Product Information

2.2.1 Product Description

Your MX actuator controls the opening and closing travel of valves and other actuated devices. OPEN and CLOSED limits are protected by an absolute encoder that provides optical sensing of valve position and measures valve position in both motor and handwheel operation. No battery or backup power supply is required. Output torque is derived from motor speed, temperature, and voltage. If the preset torque is exceeded, the motor shuts off. As a result of this reliable and advanced protection technology, all valve and other actuated devices are protected from potential damage from overload, improper seating, and foreign obstructions.

A range of control and network options is available and very simply added to the control capabilities already available on a standard actuator. Contact your local Limitorque distributor or Limitorque sales office for further information.

2.2.2 Storage

Storage Recommendations

Your MX actuator is double-sealed and weatherproof as shipped providing all compartment covers and cable entry plugs are left intact. Actuators should be stored in a clean, dry, protected warehouse until ready for wire-up. If actuators must be stored outdoors, they should be stored off the ground, high enough to prevent being immersed in water or buried in snow.

If your unit incorporates a rising stem application, it may be shipped with a plastic cap over the drive sleeve. If so, install a pipe plug or protective stem cover to protect the drive sleeve from possible corrosion.

Preferred Storage Orientation

Your MX actuator should be stored with the motor and terminal compartment in the horizontal position to obtain optimum service life.

2.2.3 Unit Weights

Table 2.2 – Unit weights

Unit	lb.	kg
MX-85	259	117
MX-140	300	136

NOTE: Weights include stem nut and lubricant.

2.3 Product Identification

2.3.1 Initial Inspection and Recording Suggestions

Upon receipt of the actuator, several steps should be initially followed to ensure condition of equipment and to establish proper record keeping.

1. After removing the actuator from the shipping carton or skid, thoroughly examine it for any physical damage which may have occurred during shipment. If you note any damage, immediately report the damage to the transport company and call Limitorque for further assistance.
2. A nameplate with important information is attached to each actuator. Record the following information for use when you need to contact Limitorque with any questions about your actuator:
 - Unit type/size
 - Limitorque order number
 - Serial number

Figure 2.2 – Accutronix MX Nameplate



2.4 Maintenance

2.4.1 Recommended Maintenance

Under normal operating conditions, the MX is a maintenance-free actuator. Therefore, for normal applications, no formal actuator maintenance is required; although visual inspection for oil leakage and excessive noise is recommended every 1 million drive sleeve turns or every 3000 cycles. When conditions are severe, due to frequent operation or high

temperatures, inspect the oil level and oil quality more often. Replace any seals that permit oil leakage or water ingress. When installing pipe plugs, use Teflon® tape or paste to achieve a proper seal.

2.4.2 Unit Lubrication

Check for proper oil level every 1 million drive sleeve turns (reference Installation and Operation Manual – Diagnostics Section to learn how to view drive sleeve turns data). Change oil every 6000 unit cycles or if water or other foreign material is found during oil inspection.

Oil Level Inspection and Fill Criteria

(Reference Lubrication Data table below for oil capacities when mounted in varying positions.)

- Actuator viewed in upright position (top-mounted handwheel up): Oil level should be approximately 1 inch (25.4 mm) below the outer surface of the housing at the oil fill port.

NOTE: Do not overfill with oil because oil will expand during actuator operation. Actuators are shipped with an oil volume suitable for any mounting position. When checking the factory-supplied oil level, excess oil may drain from the highest oil fill port due to the various mounting orientations of each application.

- Actuator viewed in side-mounted position (terminal compartment up): Oil level should be up to the bottom of the oil fill plug.
- Actuator viewed in all other positions than described previously should have the oil capacities maintained. Fill through the highest oil fill port until the oil is at a level that will contact the bottom of the pipe plug when installed in oil fill port.

Figure 2.3 – Oil Fill/Plug Locations

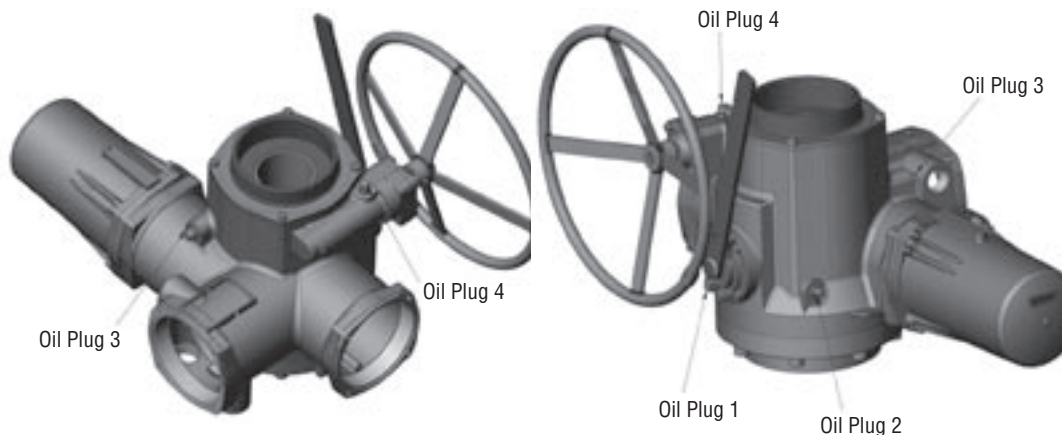

Lubrication Data

- Oil Specifications

MX actuators are oil-filled using Mobil SHC-632, which is a synthetic oil suitable for ambient temperatures of -22°F to 250°F (-30°C to 120°C). For extreme low temperature conditions, alternative lubricants are available – consult factory for further information.

Table 2.3 – MX-85 and 140 Oil Capacities when using Oil Fill/Plug Ports

Nominal Oil Capacities	oz.	liters
All Configurations	192	5.7

2.4.3 O-rings and Lubrication

O-rings and seals should be replaced anytime an actuator is disassembled. Lubricate with a substance that is compatible with Buna N seals.

2.5 Subassembly Removal and Remounting Procedures

This manual divides each MX actuator subassembly into a Removal and Remounting procedure. Use the following procedures to remove subassemblies for inspection, repair or replacement. Some subassemblies require prior subassembly removal before allowing the desired subassembly removal. Note the First Remove instructions at the beginning of each subassembly removal procedure. Remove these subassemblies first, then remove the desired subassembly according to the instructions. Once removed, evaluate subassembly components to determine requirement for a new subassembly. If a new subassembly is required, see Section 2.6, How to Order Replacement Subassemblies. Once components have been identified and replaced, remount following the appropriate Re-mounting procedures.

2.6 How to Order Replacement Subassemblies

2.6.1 Replacement Parts

Replacement parts are sold in modular subassemblies; therefore, when part replacement is required, order parts at the subassembly levels as shown in this manual. Parts may be ordered from your local Limitorque representative (see web site at www.limitorque.com) or direct from the factory:

Telephone: 1-434-528-4400

Fax: 1-434-845-9736

Please have the following information, found on the actuator nameplate, available to help us facilitate your order:

- Unit type/size
- Limitorque order number
- Serial number

2.6.2 Return Procedure

When parts are identified for warranty or other component replacement, a Return Material Authorization (RMA) must be obtained from Limitorque. All returned parts must be accompanied by documentation with the following information to obtain credit for returned goods:

- Return Material Authorization (RMA)
- Unit type/size
- Limitorque order number
- Serial number

Return parts to the address listed below:

Limitorque Actuation Systems
5114 Woodall Road
Lynchburg, VA 24502

This page is intentionally blank.

3

Remove Actuator from Mounting Adapter

3.1 Actuator Removal with Type B1/B4/B4E Base (Torque)

3.1.1 Removal (Type B1/B4/B4E Base)

STEP 1

▲ WARNING: Hazardous Voltage! Turn off all power sources to actuator before removing actuator from mounting plate. Power sources may include main power or control power. If necessary, disconnect incoming power leads L1, L2, L3, and control wiring from the terminal block.

Remove the bolts that secure the actuator to the mounting adapter.

If type B1 or B4E base is used in addition to the standard type B4 baseplate, you may leave the B1 base attached to the mounting adapter and remove the actuator only. Or if required, you may remove the bolts that mount type B1 base to mounting adapter.

This will allow actuator removal along with optional B1 base.



STEP 2

▲ WARNING: Potential high pressure vessel!
Before disassembling your actuator, ensure that the valve or other actuated device is isolated and is not under pressure.

Lift actuator from mounting adapter.



3.1.2 Remounting (Type B1/B4/B4E Base)

STEP 3

Ensure stem nut (#1-22) is secured inside actuator drive sleeve with retaining ring (#1-23). Lower actuator onto the mating component, making sure to align stem nut key and keyway with mating component.

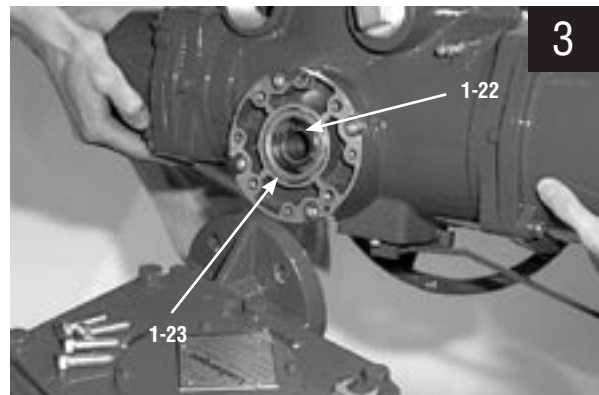

STEP 4

Ensure that the actuator and mounting adapter flange mating holes are aligned correctly.



STEP 5

▲ WARNING: Hazardous Voltage! Turn off all power sources before rewiring incoming power leads L1, L2, L3, and control wiring in the terminal block.

Secure the actuator to the mounting adapter with mounting bolts.



STEP 6

Reconnect incoming power leads L1, L2, L3, and control wiring to the terminal block. Restore power source when ready for operation.

3.2 Actuator Removal with Type A1/A1E Base (Thrust)

NOTE: Two procedure options are available for removing the actuator and thrust base:

1. Remove actuator from thrust base, leaving thrust base mounted to mounting flange or removing thrust base separately.
2. Remove actuator and thrust base as a unit from mounting flange.

3.2.1 Removal (Type A1/A1E Base)—Actuator removal separate from thrust base

STEP 1

▲ WARNING: Hazardous Voltage! Turn off all power sources to actuator before removing actuator from mounting plate. Power sources may include main power or control power. If necessary, disconnect incoming power leads L1, L2, L3, and control wiring from the terminal block.

Remove the bolts (#10-10) that secure the actuator to the thrust base assembly (#10).

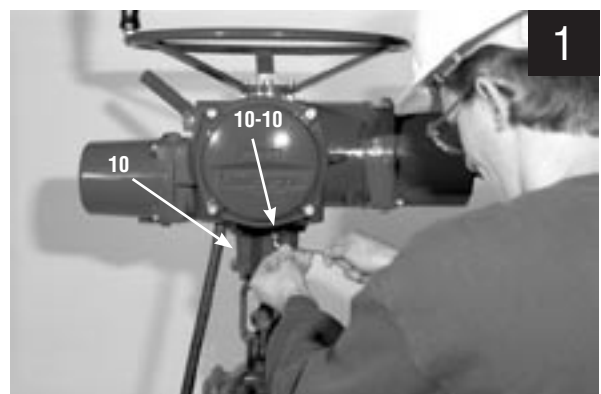

STEP 2

▲ WARNING: Potential high-pressure vessel!
Before disassembling your actuator, ensure that the valve or other actuated device is isolated and is not under pressure.

Lift actuator from thrust base assembly (#10).

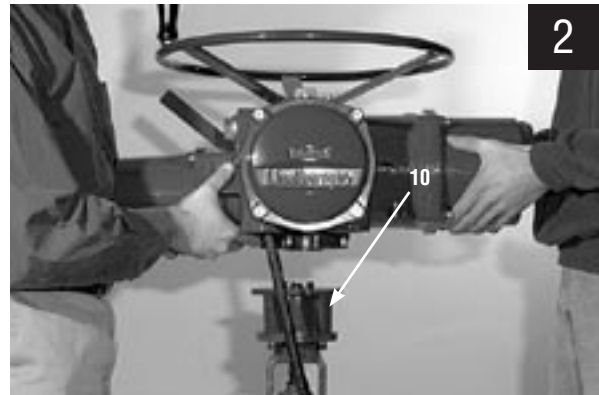

STEP 3

▲ WARNING: Potential for actuated device to change position! The thrust base will maintain position only if non-backdriving thread lead is used. Ensure proper thread lead is used in your application before allowing thrust base to be used for maintaining position when actuator is removed.

Thrust base removal (if required)

The valve position will be maintained if a locking thread lead is used on the valve stem. If thrust base removal is required, use the following removal procedure.

Remove the bolts that secure the thrust base to the mounting adapter.



STEP 4

Rotate the thrust base (#10) until it feeds off the threaded stem.



3.2.2 Remounting (Type A1/A1E Base)—Actuator remounting separate from thrust base

STEP 5

Thrust base remounting (if required)

Ensure the thrust base stem nut has the two lugs positioned upward to engage with the drive sleeve slots when actuator is reinstalled onto thrust base. Thread thrust base back onto mounting adapter.



STEP 6

Secure thrust base to mounting adapter with mounting bolts.



STEP 7

Actuator remounting

Lower the actuator onto the thrust base, making sure thrust nut lugs align and properly engage with drive sleeve slots.



STEP 8

Install bolts (#10-10) to secure the actuator to the thrust base assembly (#10).



STEP 9

▲ WARNING: Hazardous Voltage! Turn off all power sources before rewiring incoming power leads L1, L2, L3, and control wiring in the terminal block.

Reconnect incoming power leads L1, L2, L3, and control wiring to the terminal block. Restore power source when ready for operation.

3.2.3 Removal (Type A1/A1E Base)—Actuator and thrust base as a unit

STEP 1

▲ WARNING: Hazardous Voltage! Turn off all power sources to actuator before removing actuator from mounting plate. Power sources may include main power or control power. If necessary, disconnect incoming power leads L1, L2, L3, and control wiring from the terminal block.

Actuator + thrust base removal

Remove the bolts that secure the actuator and thrust base (#10) to the mounting adapter.



STEP 2

▲ WARNING: Potential high-pressure vessel!
Before disassembling your actuator, ensure that the valve or other actuated device is isolated and is not under pressure.

Declutch the actuator to manual mode.



STEP 3

Rotate the handwheel until the actuator lifts off the threaded stem.



3.2.4 Remounting (Type A1/A1E Base)—Actuator and thrust base as a unit

STEP 4

Actuator + thrust base remounting

Declutch the actuator to manual mode. Lift actuator up to the threaded stem and carefully align threads with thrust base threaded stem nut.



STEP 5

Rotate the handwheel to lower the actuator along the threaded stem and onto the mounting adapter plate.

**STEP 6**

Install the mounting bolts to secure the actuator and thrust base (#10) to the mounting adapter.

**STEP 7**

▲ WARNING: Hazardous Voltage! Turn off all power sources before rewiring incoming power leads L1, L2, L3, and control wiring in the terminal block.

Reconnect incoming power leads L1, L2, L3, and control wiring to the terminal block. Restore power source when ready for operation.

4 Mechanical Assemblies

4.1 Motor

NOTE: Proper motor testing is required when replacing motor. Consult your Limerorque representative or the Limerorque factory to replace with correct motor.

Table 4.1 – Motor Parts List

Part Number	Description	Qty.
4-1	Motor Cover	1
4-2	Stator	1
4-3	Rotor Assembly	1
4-4	Bearing	1
4-8	Bearing Preload Spring	1
4-9	Setscrew	1

Figure 4.1 – Motor

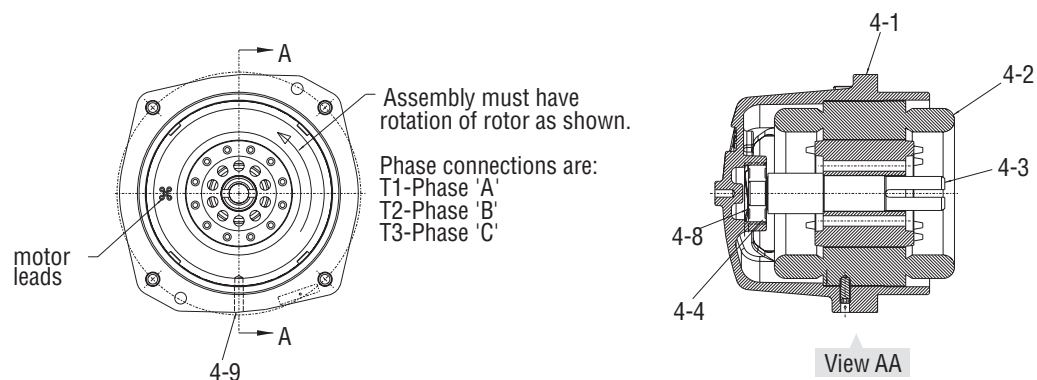

4.1.1 Removal

STEP 1

- ⚠ **WARNING:** Hazardous Voltage! Turn off all power sources to actuator before removing motor assembly. Power sources may include main power or control power.

Using an M8 hex key, remove the four M10 screws (#1-14) that mount the motor assembly to the actuator.

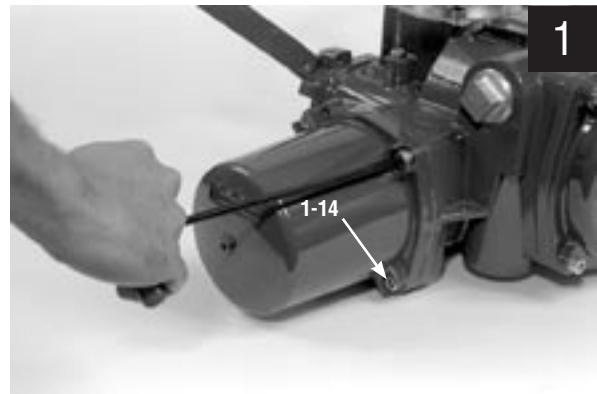

STEP 2

- ⚠ **CAUTION:** The rotor is not connected to the motor housing; when removing the motor, ensure the rotor is carefully removed and not dropped from the motor housing.

Withdraw the complete motor (subassembly #4), including the rotor (#4-3), until the wiring harness is accessible. Note the O-ring (#1-15) on the spigot/pilot of the motor assembly; replace at remounting.

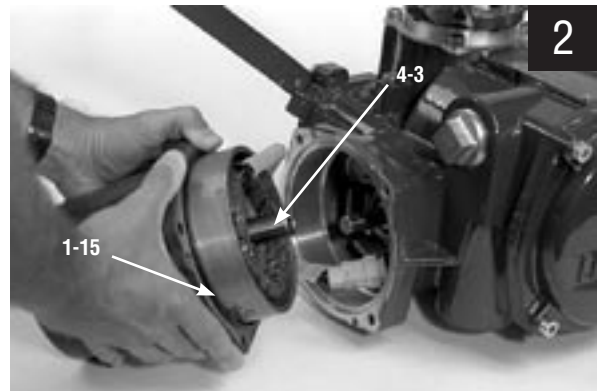

STEP 3

Disconnect the motor power plug from the motor power socket connector.



4.1.2 Remounting

STEP 4

⚠ WARNING: Hazardous Voltage! Turn off all power sources to actuator before removing motor assembly. Power sources may include main power or control power.

Lightly lubricate O-ring (#1-15) that is installed around the motor spigot/pilot (subassembly #4).

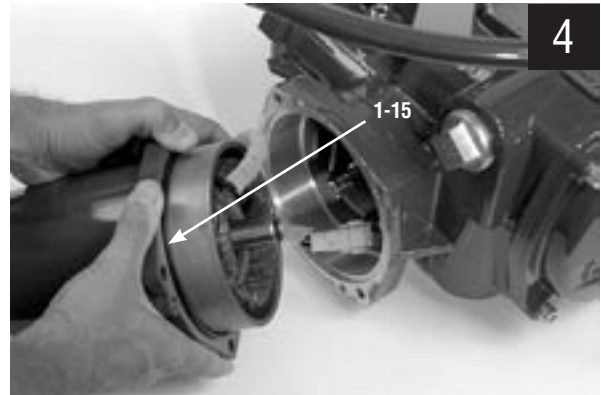

STEP 5

Hold the motor assembly (housing/stator/rotor) close to the actuator housing and reconnect the motor power plug to the motor power socket connector.

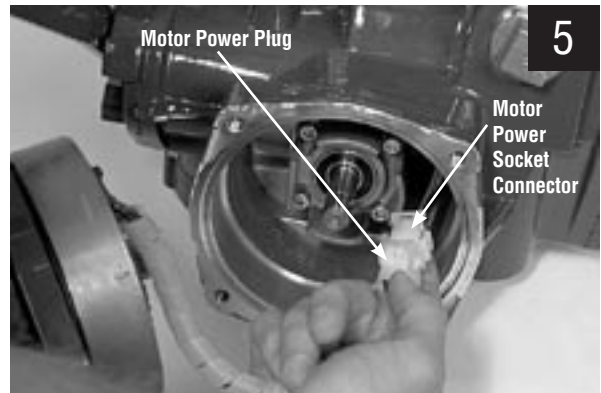

STEP 6

Coil the spiral-wrapped motor power wiring inside the motor cavity and around the motor bearing housing to ensure that it does not come into contact with the rotor shaft.

The motor wiring will wrap around about 180°.



STEP 7

Push the rotor shaft onto the protruding worm shaft, aligning the rotor shaft slots with the worm shaft pin. Slide the motor housing spigot/pilot into the actuator housing.

**STEP 8**

Fit the four screws (#1-14) into the motor subassembly mounting holes and tighten.

4.2 Declutch

Table 4.2 – Declutch Parts List

Part Number	Description	Qty.
5-1	Declutch Cover	1
5-2	Declutch Shaft	1
5-3	Declutch Cam	1
5-4	Declutch Spring	1
5-9	Retaining Ring	2
5-10	Socket Head Set Screw	1
5-11	O-ring	1
5-12	Socket Head Set Screw	2
5-13	Spiral Pin	1
5-15	O-ring	1
5-16	Pipe Plug	1

Figure 4.2 – Declutch

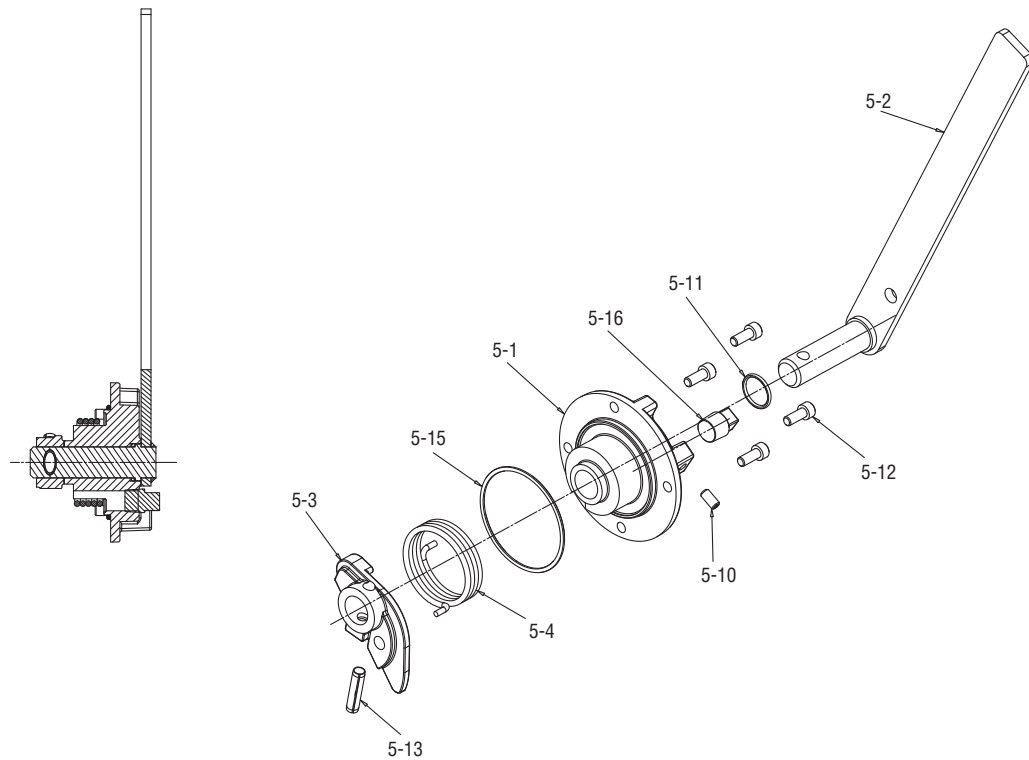

4.2.1 Removal

NOTE: The declutch assembly may be removed and remounted without other subassembly removal.

STEP 1

⚠ WARNING: Potential to operate while dangerous mechanical parts are exposed during subassembly removal. To prevent injury, turn off all power sources to actuator before removing side-mounted handwheel assembly. Power sources may include main power or control power.

Drain oil from actuator using the lowest of three plugs in your application mounting orientation.

NOTE: Oil removal is not necessary on if actuator is mounted with declutch lever up.

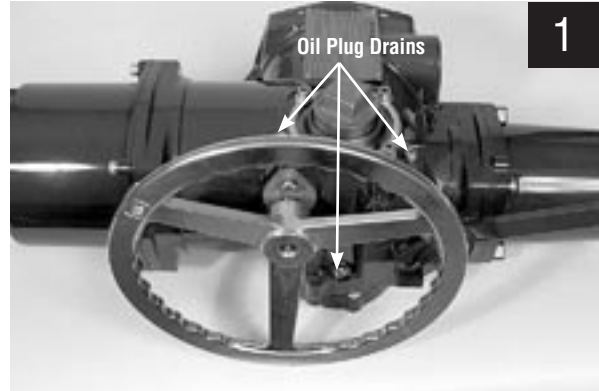

STEP 2

⚠ WARNING: Potential to operate while dangerous mechanical parts are exposed during subassembly removal. To prevent injury, turn off all power sources to actuator before removing declutch assembly. Power sources may include: main power or control power.

Using a 6 mm hex key, remove the four M8 screws that retain the declutch assembly cover (#5-1) on the actuator housing.

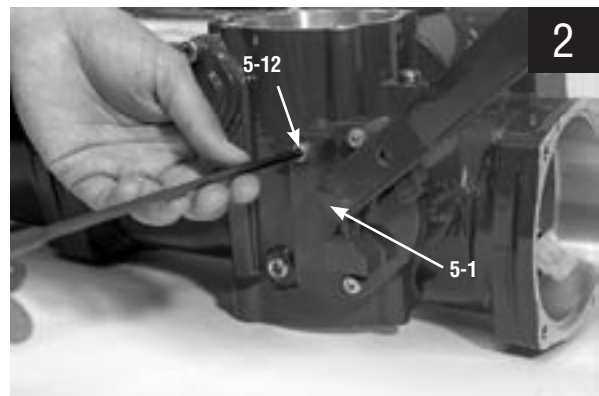

STEP 3

Withdraw the complete declutch assembly, slightly twisting, if necessary, to remove. Note the O-ring (#5-15) with the declutch assembly cover (#5-1). Replace at remounting.

Picture 3 is a typical MX-85/140.



4.2.2 Remounting

STEP 4

Lightly lubricate the O-ring (#5-15) and fit it to the inner race of the declutch cover (#5-1).

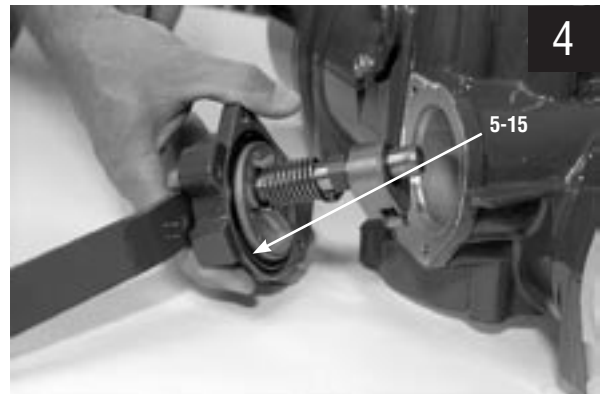

STEP 5

Tip: Picture 5a shows proper alignment between the cam and the clutch ring roller.

Fit the complete declutch assembly into the actuator housing, slightly twisting, if necessary, to remount into actuator.



STEP 6

Set screw adjustment. Install drive sleeve, base-plate, clutching and handwheel worm gear components. Assure the clutch lugs are fully engaged to the motor worm gear lugs before the adjustment. With declutch lever resting on cap pad (not the set screw) place declutch cap assembly (1-4) into housing without mounting screws. Rotate cap assembly clockwise until declutch cam is resisted by the roller, clutch ring and clutch combination. Holding the declutch lever, rotate the set screw clockwise thru declutch cap, (this will rotate the cap counterclockwise) until the cap mounting holes are inline with the taps in the housing. Install declutch assembly mounting screws. Then rotate set screw counterclockwise $\frac{1}{4} \pm \frac{1}{8}$ turn. Adjustment is complete.

STEP 7

Fit the four M8 screws to retain the declutch assembly cover (#5-1) on the housing. Tighten using a 6 mm hex key. Picture 7 shows the four screws.



4.3 Side-Mounted Handwheel with Spur Gear Attachment

Table 4.3 – Side-Mounted Handwheel Parts List

Part Number	Description	Qty.
13-1	Handwheel Worm Shaft	1
13-2	Spur Adapter Plate	1
13-3	Ball Bearing	1
13-5	Spiral Pin	1
13-6	Gasket	1
13-7	Key	1
13-8	Needle Bearing	1
13-9	Socket Head Cap Screw M8x25	4
13-10	Side-Mounted Handwheel	1
13-11	Ball Bearing	1
13-12	Handwheel Input Gear	1
13-13	Spur Adapter Cap	1
13-14	Handwheel Input Pinion	1
13-15	Oil Seal	1
13-17	Dowel Pin	1
13-18	Set Screw	1
13-19	Gasket	1
13-20	Socket Head Cap Screw M8x20	4
13-22	Ball Bearing	1
13-23	Ball Bearing	1
13-24	Key	2
13-28	Retaining Ring	1

Figure 4.3 – Side-Mounted Handwheel With SGA

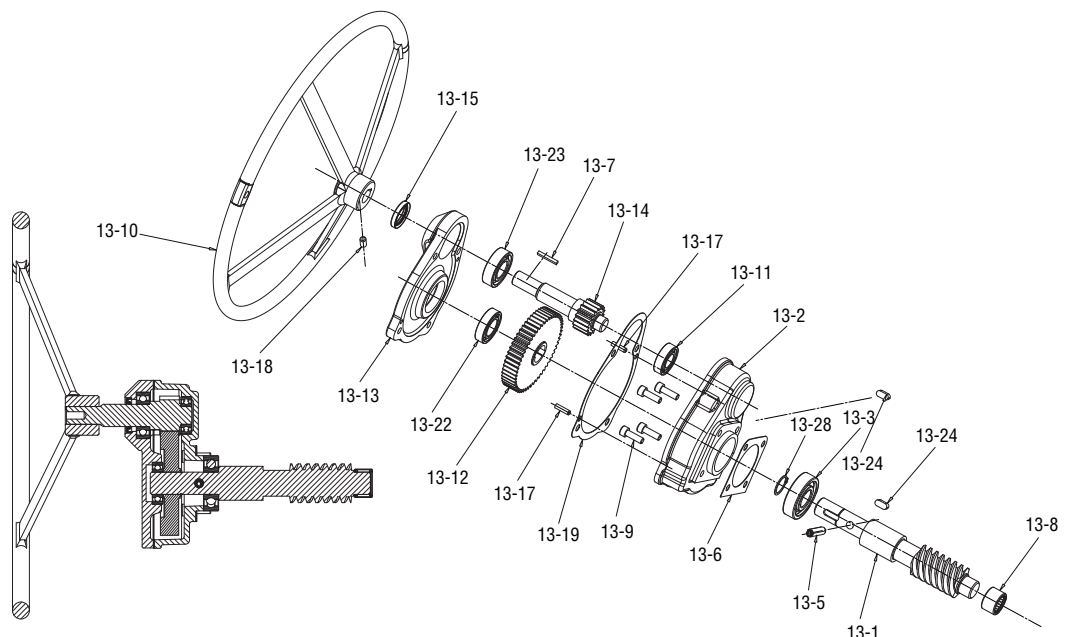

4.3.1 Removal of Handwheel

NOTE: The handwheel is mounted with a set screw (#13-18) and a key (#13-7). See pictures a and b.



STEP 4

Remove the four M6 screws (#13-9) from the worm shaft plate (#13-2).

4.3.2 Removal

STEP 1

⚠ WARNING: Potential to operate while dangerous mechanical parts are exposed during subassembly removal. To prevent injury, turn off all power sources to actuator before removing side-mounted handwheel assembly. Power sources may include: main power or control power.

Drain oil from actuator using the lowest of three plugs in your application orientation.

NOTE: Oil removal is not necessary if the actuator is mounted on valve or other device with the drive sleeve in a vertical position.

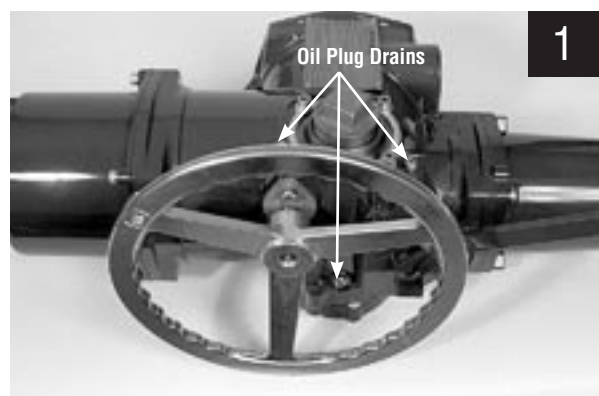

STEP 2

▲ CAUTION: Be aware of the inner bearing (#13-8) when removing the side-mounted handwheel. It may stay in the actuator housing or come out with the side-mounted handwheel assembly. Ensure it is inserted back in actuator housing before remounting side-mounted handwheel assembly.

Remove the four screws (#13-20) from the hand-wheel spur gear cap (#13-13).

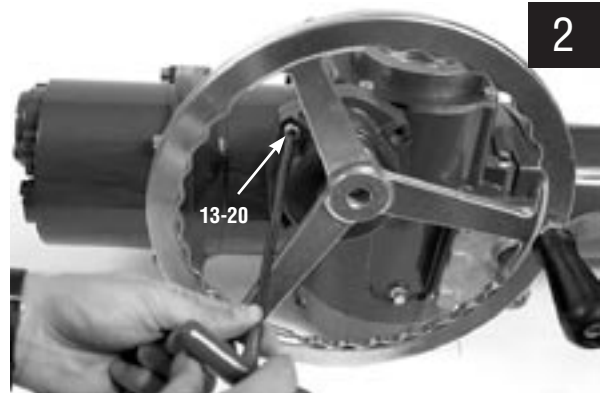

STEP 3

Remove handwheel spur gear cap assembly. Note when assembly is removed, the spur gear (#13-12) is loose in spur gear cap. Remove spur gear.

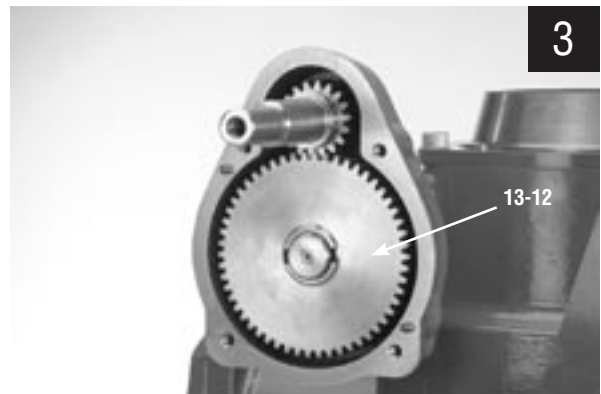

STEP 4

Remove the four M6 screws (#13-9) from the worm shaft plate (#13-2).

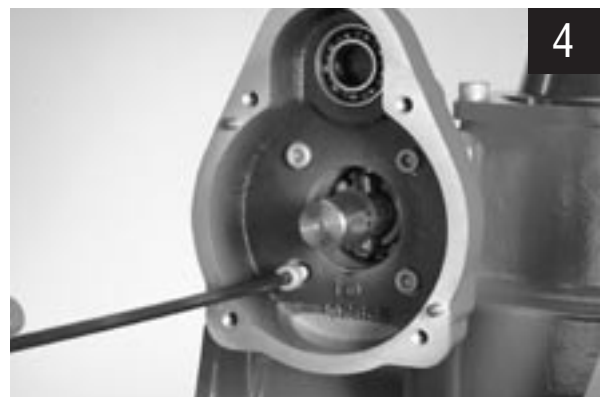

STEP 5

Removing worm shaft assembly.

Remove adapter plate, then remove worm assembly.

NOTE: When removing the side-mounted handwheel, the inner bearing (#13-8) should remain in place in the housing.

Rotate the handwheel assembly clockwise (CW) to withdraw the complete worm shaft plate subassembly.



STEP 6

If needed, remove the handwheel worm gear assembly (#12). (See Section 4.8.2 for removal procedure).



4.3.3 Remounting

STEP 7

Check that bearing (#13-8) is correctly in place in the actuator housing, it is press fit in the housing.

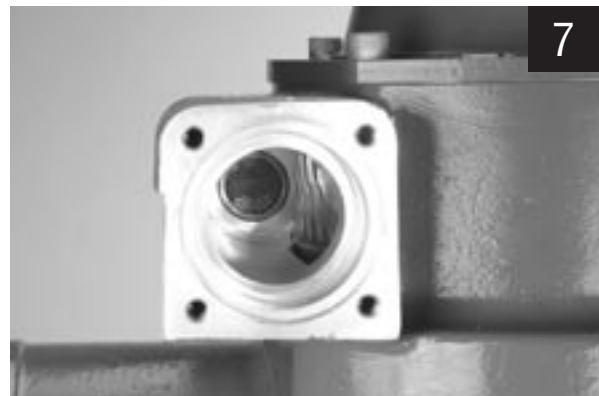

STEP 8

If previously removed, install handwheel worm gear assembly (#12). (See Section 4.8.2 for remounting procedure).



STEP 9

Insert worm shaft assembly into actuator housing. Rotate assembly in counterclockwise (CCW) direction to properly mate with handwheel worm gear assembly (#12).



STEP 10a AND b

Ensure gasket (#13-6) is placed on adapter (#13-2) and install adapter to housing and secure with four M8 screws (#13-9).



STEP 11a AND 11b

Fit gear (#13-12) onto end of worm shaft. Ensure both keys (#13-24) are in place in worm shaft.

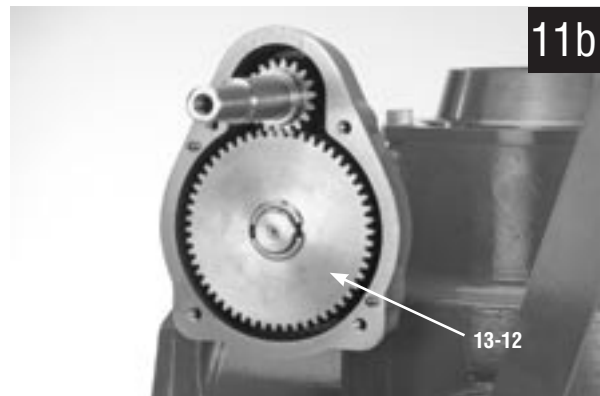
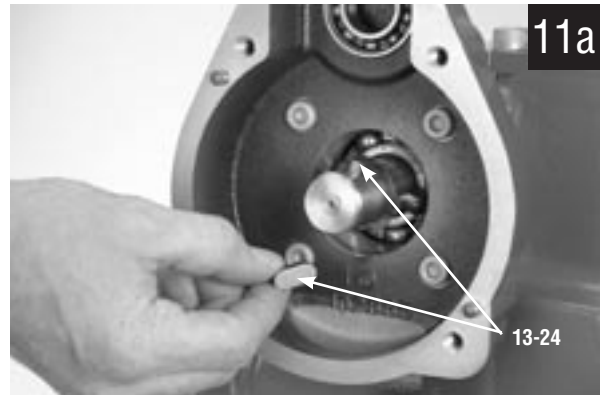

STEP 12

Ensure gasket (#13-19) is in place on adapter (#13-2).

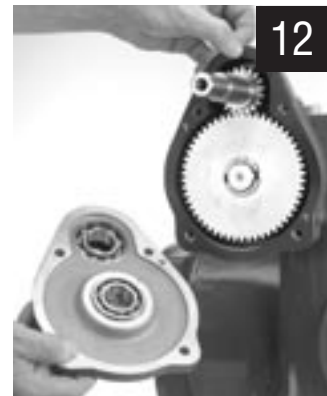

STEP 13

Check that seal (#13-15), and ball bearings (#13-11, 13-22, and 13-23) are correctly placed in adapter (#13-2) and cap (#13-13).

Install handwheel spur cap assembly. Secure with screws (#13-20). Remount handwheel (#13-10) if removed with key (#13-7) and set screw (#13-18).

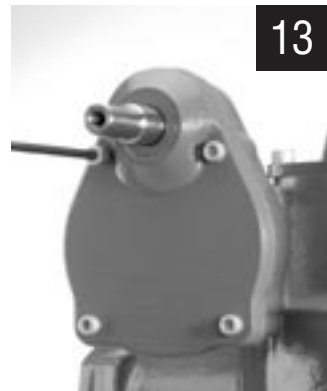

4.4 Thrust Base Type A1/A1E

Table 4.4 – Type A1 Thrust Base Parts List

Part No.	Description	Qty.
10-1	Thrust Base Housing	1
10-2	Thrust Pilot	1
10-3	Thrust Nut (A1 or A1E)	1
10-6	Socket Head Cap Screw	2
10-7	Washer	2
10-10	Socket Head Cap Screw	1
10-10	Hex Head Cap Screws	2
10-11	Grease Fitting	4
10-12	Thrust Bearing	2
10-13	Thrust Washer	1
10-16	Quad Ring	8
10-17	Gasket	1

Figure 4.4 – Type A1 Thrust Base – F25 Flange

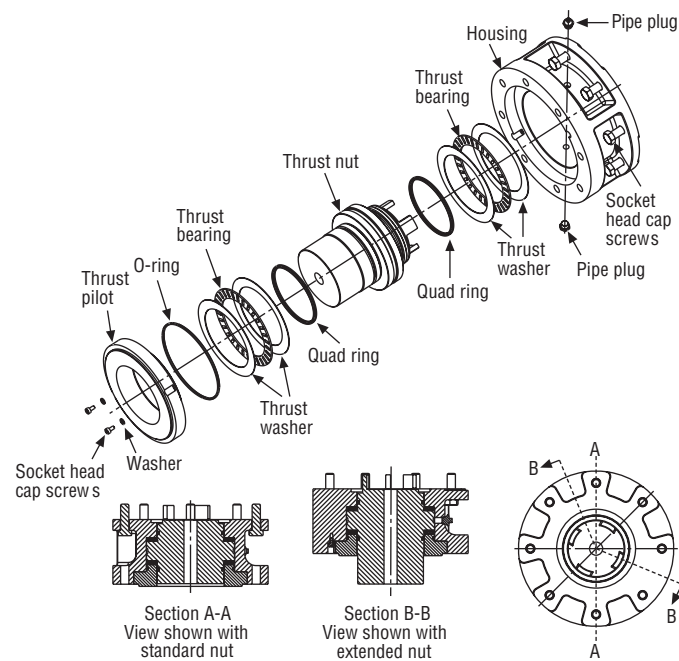
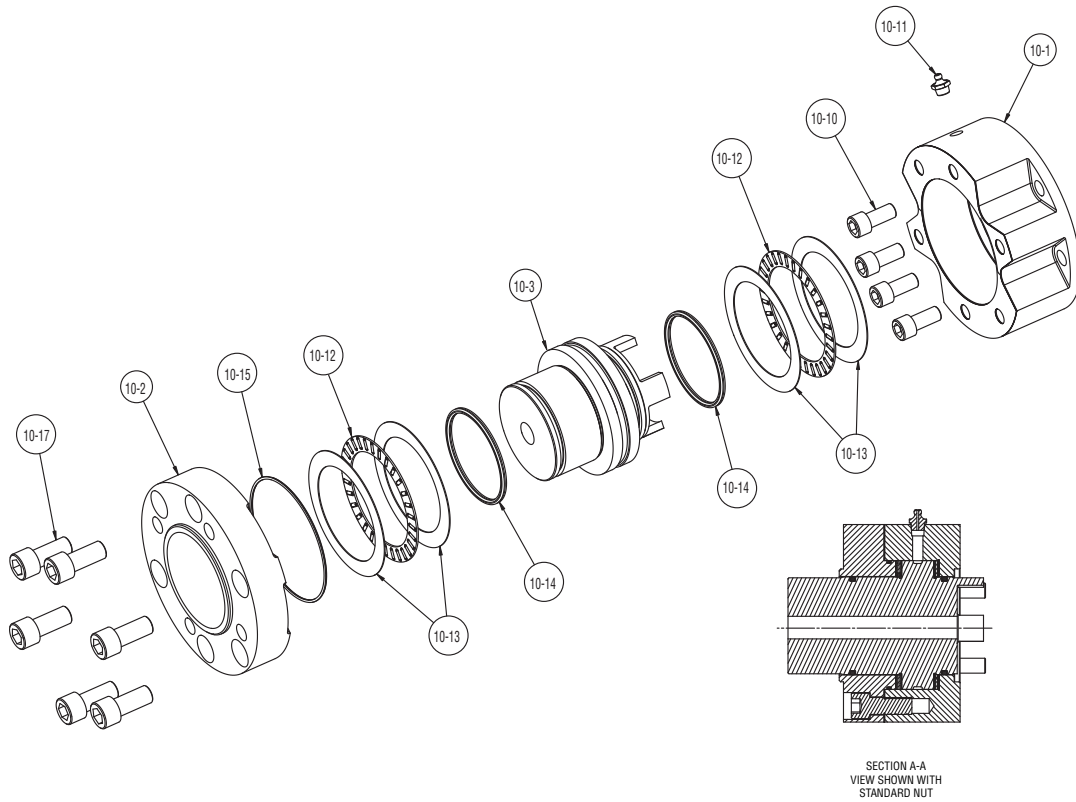

Table 4.5 – Type A1 Thrust Base Parts List (MX-85)

Part Number	Description	Qty.
10-1	Thrust Base Housing	1
10-2	Thrust Base	1
10-3	Thrust Nut (A1 or A1E)	1
10-10	Socket Head Cap Screw	1
10-11	Grease Fitting	1
10-12	Thrust Bearing	2
10-13	Thrust Washer	4
10-14	Quad Ring	2
10-15	O-ring	1
10-17	Socket Head Cap Screw	6

Figure 4.5 – Type A1 Thrust Base (MX-85) - F16 Flange



4.4.1 Removal

First Remove

1. Remove actuator from mounting adapter.

STEP 1

▲ WARNING: Potential to operate while dangerous mechanical parts are exposed during subassembly removal. To prevent injury, turn off all power sources to actuator before removing thrust base assembly. Power sources may include: main power or control power.

Remove the four screws (#10-10) and pull the thrust base assembly off the actuator.



4.4.2 Remounting

STEP 2

Secure the thrust base with the four screws (#10-10).



4.5 Baseplate Type B4

Table 4.6 – Type B4 Baseplate Parts List

Part Number	Description	Qty.
11-1	Baseplate	1
11-3	Seal-Quad Ring	1
11-4	O-ring	1
11-5	Socket Head Cap Screw	8

Figure 4.6 – Type B4 Baseplate

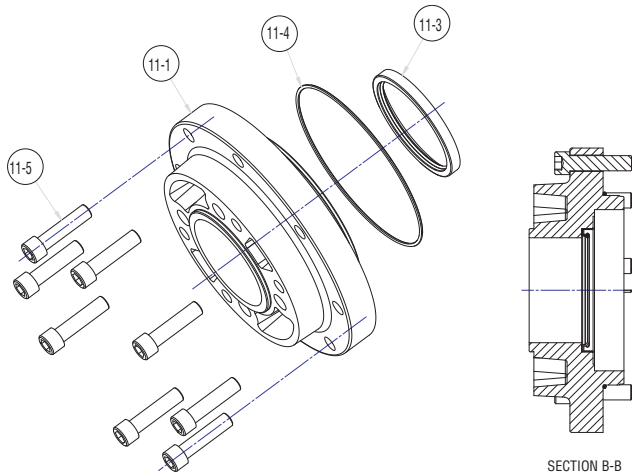

Stem Nuts (B4, B4E, and BL) Various stem nuts are used with the B4 baseplate:

1. B4 stem nut with variable bore and key
2. B4E stem nut for extended reach and variable bore and key
3. BL stem nut (6 or 36 splines)

The B4 stem nut is secured by a snap ring and the B4E and BL stem nuts are secured by a spiral-wound ring. Reference the MX Installation Manual LMAIM1306 for more information about stem nut options.

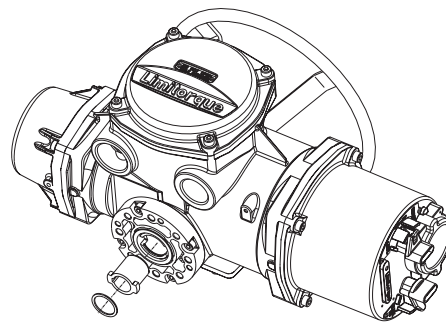

Typical MX actuator with standard B4 stem nut and snap ring

4.5.1 Removal

First Remove

1. Remove actuator from mounting adapter.
2. Drain oil.
3. Remove thrust base (subassembly #10) - if fitted.
4. Remove stem nut.

STEP 1

▲ WARNING: Potential to operate while dangerous mechanical parts are exposed during subassembly removal. To prevent injury, turn off all power sources to actuator before removing base plate assembly. Power sources may include main power or control power.

Using a hex key, remove the eight screws (#11-5).

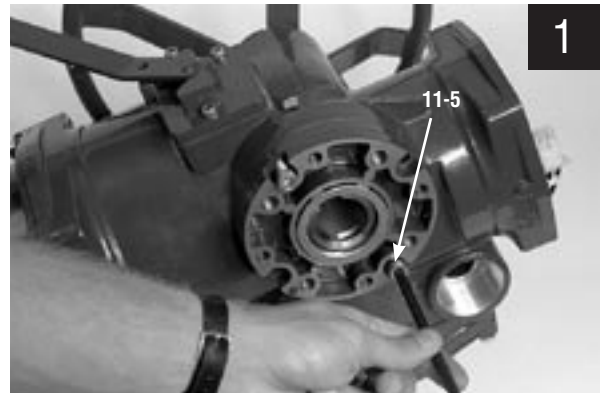

STEP 2

Pull the baseplate (#11-1) off the drive sleeve.

⚠ WARNING: If handwheel worm gear assembly has previously been removed, the drive sleeve assembly may slip and fall out of housing. Hold drive sleeve assembly in from opposite end. See Sections 4.7.3 and 4.7.4 for optional removal and remounting.

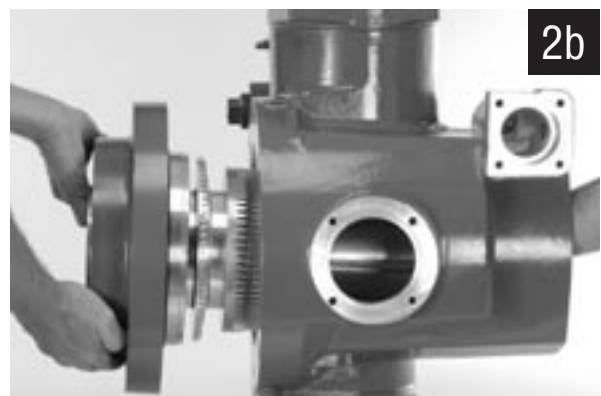
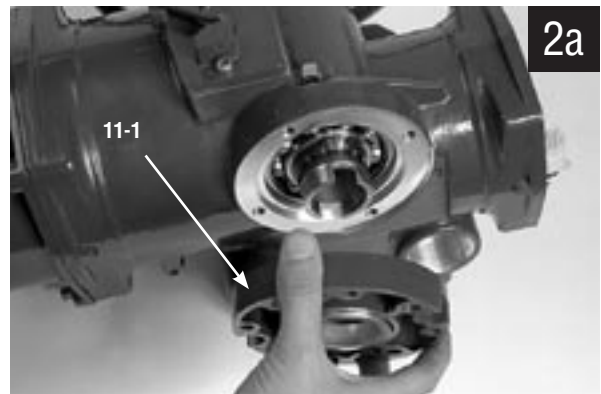

4.5.2 Remounting

STEP 3

▲ CAUTION: To ensure actuator is fully secured on mounting plate, ensure baseplate (#11-1) is tightened with 90 ft-lb (114 N m) on mounting screws (#11-5).

Lightly lubricate the outside of the drive sleeve, the quad ring or seal (#11-3), and O-ring (#11-4) before remounting baseplate.

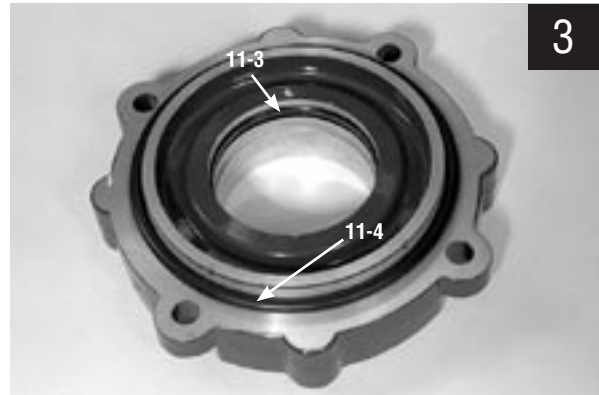

STEP 4

NOTE: Match mounting holes in baseplate to housing taps. Baseplate and housing has one hole/tap that is not equally spaced.

Carefully push the baseplate assembly onto the end of the drive sleeve, ensuring that the quad ring or seal (#11-3) is not damaged. Align the mounting holes and secure the baseplate with the screws (#11-5).



4.6 Worm Shaft

Table 4.7 – Worm Shaft Parts List

Part Number	Description	Qty.
3-1	Worm	1
3-2	Worm Shaft Cap	1
3-3	Ball Bearing	1
3-4	Ball Bearing	2
3-6	Oil Seal	1
3-7	O-ring	1
3-8	Pin	2
3-9	Socket Head Cap Screw	4

4.6.1 Removal

First Remove

1. Remove actuator from mounting adapter.
2. Drain oil.
3. Remove motor (subassembly #4). (See Section 4.1.1.)

STEP 1

▲ WARNING: Potential to operate while dangerous mechanical parts are exposed during subassembly removal. To prevent injury, turn off all power sources to actuator before removing worm shaft assembly. Power sources may include: main power or control power.

Remove the four screws (#3-5) that secure the worm shaft cap (#3-2) to the actuator housing.

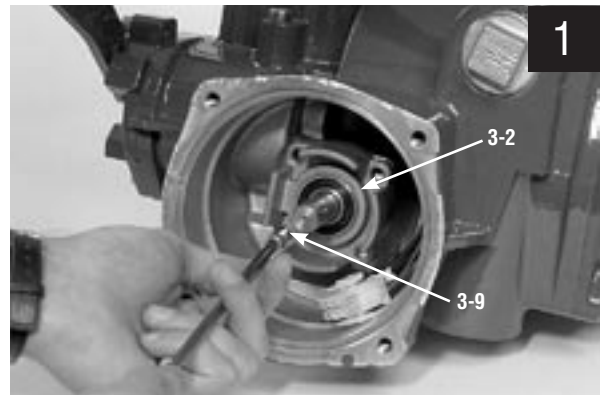

STEP 2

NOTE: The inboard bearing (#3-5), at the end of the worm shaft (#3-1) should remain in the actuator housing. If it falls out while removing the worm shaft assembly, ensure it is replaced during remounting process.

Withdraw the complete worm shaft assembly from the actuator housing, turning/rotating it if necessary to free the worm from the worm gear. Note the O-ring (#3-7) that is on the worm shaft assembly. Replace at remounting.

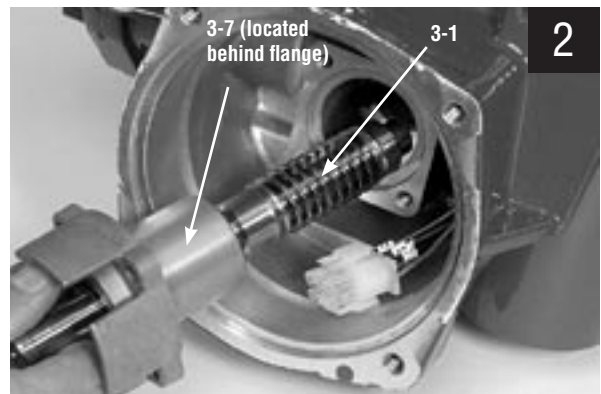

4.6.2 Remounting

STEP 3

Check that the bearing (#3-5) is seated firmly in the actuator housing.



STEP 4

NOTE: Lightly lubricate O-ring (#3-7) before remounting worm shaft (subassembly #3).

Push the complete worm shaft assembly into the actuator housing until the worm contacts the worm gear. Turn the worm so it engages the worm gear and continue rotating until the end of the worm shaft is isolated in the inboard bearing (#3-4).

Be sure the motor wiring harness is pushed in, then rotate worm shaft cap (#3-2) around so that tab is holding wiring harness in place. See Section 5.9 for motor wiring harness installation.

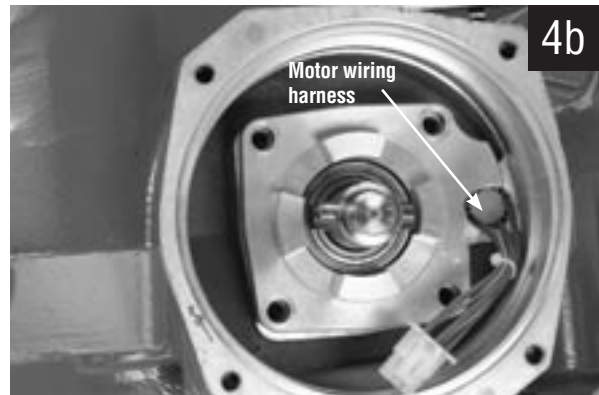
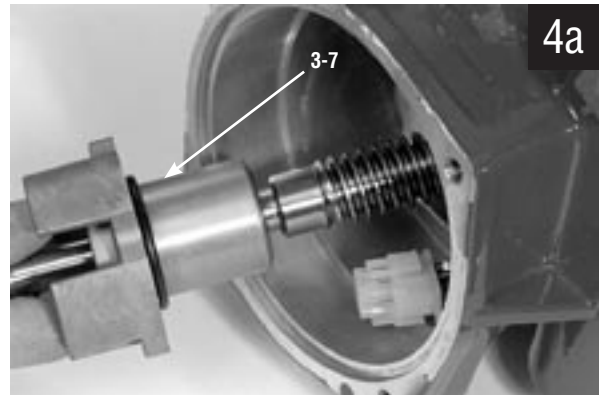

STEP 5

Using a hex key, fit the four M10 screws (#3-9) into worm shaft cap (#3-2) mounting holes and tighten.

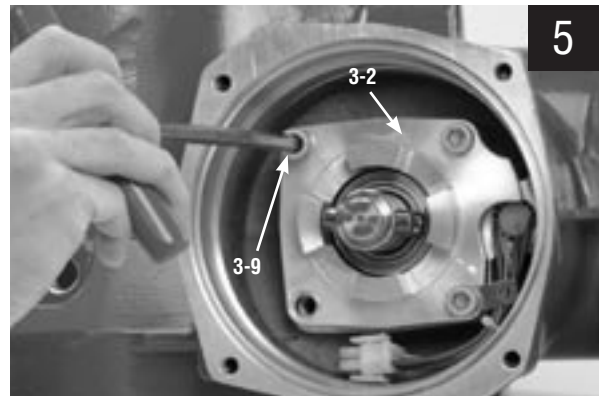

4.7 Drive Sleeve

Table 4.8 – Drive Sleeve Parts List

Part Number	Description	Qty.	Qty. 10:1 and 13:1 Ratio
2-1	Drive Sleeve	1	1
2-2	Worm Gear	1	1
2-3	Encoder Drive Gear	1	1
2-4	Ball Bearing	1	1
2-6	Drive Sleeve Key	1	1
2-7	Spacer	N/A	3
2-8	Ball Bearing	N/A	2
2-9	Retaining Ring	N/A	1

Figure 4.7 – 10:1 and 13:1 ratio

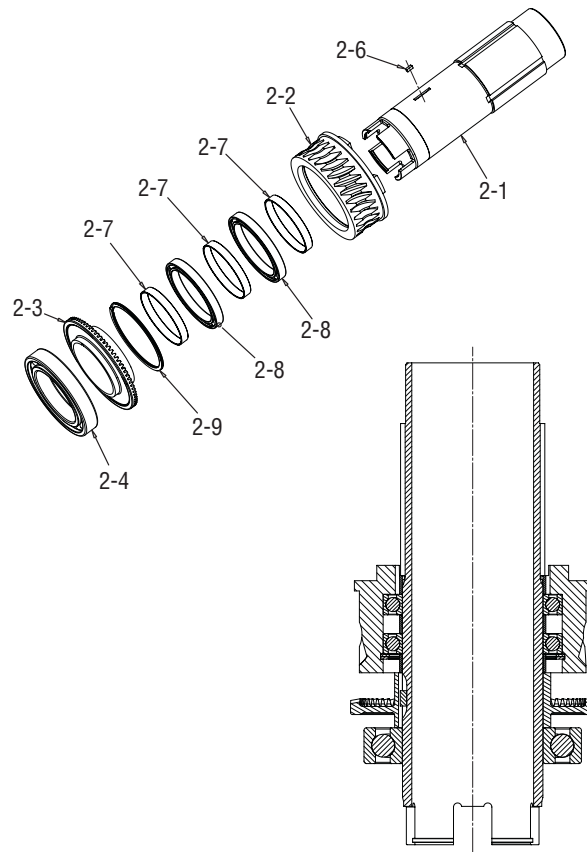

4.7.1 Removal

First Remove

1. Remove actuator from mounting adapter.
2. Drain oil.
3. Remove thrust base (subassembly #10) - if fitted. (See Section 4.4.1.)
4. Remove motor (subassembly #4). (See Section 4.1.1.)
5. Remove worm shaft (subassembly #3). (See Section 4.6.1.)
6. Remove side-mounted handwheel (subassembly #16). (See Section 4.3.1.)
7. Remove handwheel worm gear (subassembly #12). (See Section 4.8.1.)
8. Remove clutch and clutch ring (subassembly #16). (See Section 4.9.1.)
9. Remove handwheel declutch (subassembly #5). (See Section 4.2.1.)
10. Remove base plate (subassembly #11). (See Section 4.5.1. or Section 4.7.3)

- ⚠ **WARNING:** The drive sleeve assembly may slip and fall out of housing when removing baseplate assembly. Hold drive sleeve assembly in from opposite end when removing baseplate assembly. See optional drive sleeve and baseplate removal Section 4.7.3 and 4.7.4.

STEP 1

- ⚠ **WARNING:** Potential to operate while dangerous mechanical parts are exposed during subassembly removal. To prevent injury, turn off all power sources to actuator before removing drive sleeve assembly. Power sources may include: main power or control power.

Once all other subassemblies are removed, pull out the drive sleeve assembly (#2) until the lower bearing (#2-4) is released from the actuator housing. Remove drive sleeve assembly from actuator.



STEP 2

(Viewed from baseplate side of actuator)

Tip: To avoid interference between drive sleeve assembly and encoder drive cartridge (subassembly #14), turn flat on worm gear to be parallel and on same side as encoder bevel gear.

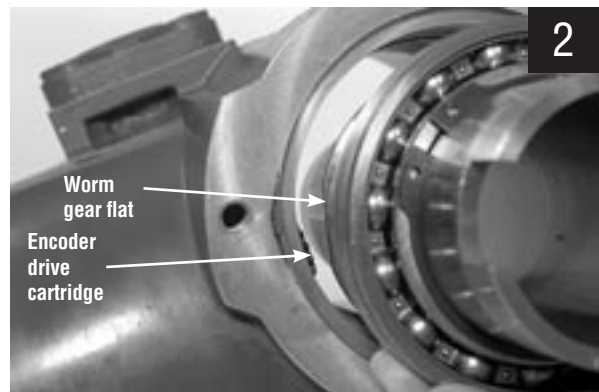

STEP 3

(Viewed from top-mounted handwheel side of actuator)

Tip: Worm gear flat turned parallel with encoder drive cartridge (subassembly #14) to permit drive sleeve assembly removal.

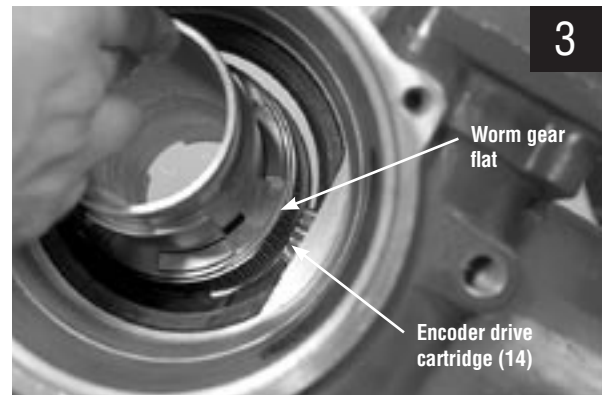

4.7.2 Remounting

STEP 4

NOTE: Before remounting drive sleeve assembly, ensure that bearing (#3-5) is in place in the actuator housing. (Refer to motor subassembly #3 Step 1 for details.)

Lightly lubricate the top and bottom of the drive sleeve assembly as shown.

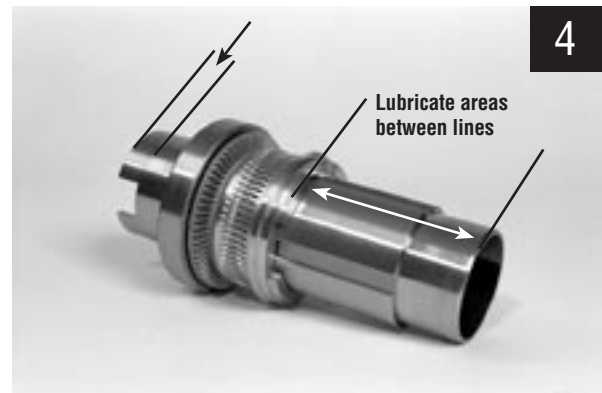

STEP 5

Push the drive sleeve assembly into the base of the actuator housing until the lower bearing (#2-4) is fully engaged in the housing up to the shoulder. If the bearing is a tight fit, gently tap the bottom of the drive sleeve (#2-1) with a mallet to properly seat.

See Section 4.7.4 for optional remounting of drive sleeve and baseplate.

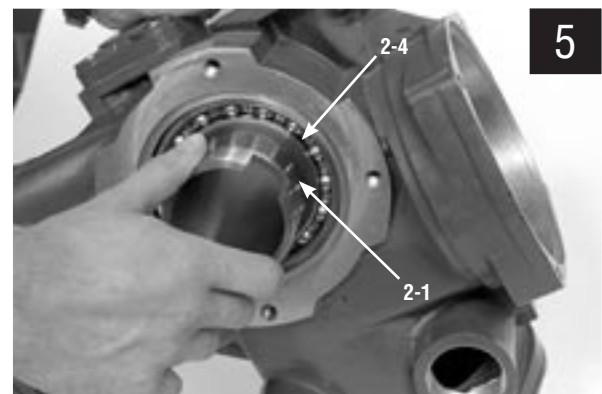

4.7.3 Optional Drive Sleeve and Baseplate Removal

First remove

1. Remove actuator from mounting adapter.
2. Drain oil.
3. Remove thrust base (subassembly #10) - if fitted. (See Section 4.4.1.)
4. Remove motor (subassembly #4). (See Section 4.1.1.)
5. Remove worm shaft (subassembly #3). (See Section 4.6.1.)
6. Remove side-mounted handwheel (subassembly #16). (See Section 4.3.1.)
7. Remove handwheel worm gear (subassembly #12). (See Section 4.8.1.)
8. Remove clutch and clutch ring (subassembly #16). (See Section 4.9.1.)
9. Remove handwheel declutch (subassembly #5). (See Section 4.2.1.)

STEP 1

Lay actuator on its side with the drive sleeve horizontal. Using a hex key, remove seven of the baseplate screws (#11-5).



STEP 2

Lay actuator on a table or suitable structure with one of the screws (#11-5) hanging over the edge. Remove screw. If needed, rotate actuator around and remove all other screws.

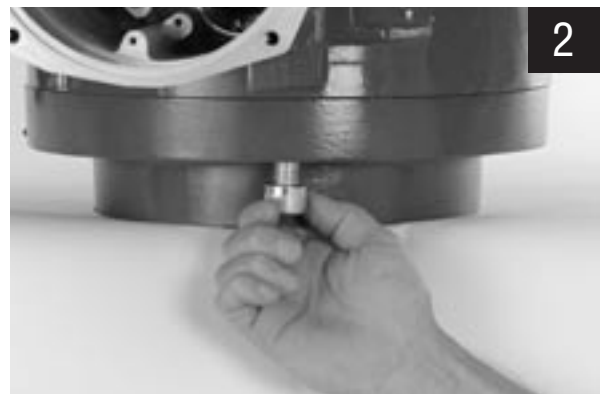

STEP 3

With help, lift housing straight up and off baseplate and drive sleeve assemblies.



STEP 4

Using the encoder gear (#2-3), lift drive sleeve assembly out of the baseplate assembly. Turn the drive sleeve assembly over (lugs of drive sleeve up) and set down on table.

NOTE: The drive sleeve assembly is not held together and will fall apart if set down on a lug end of drive sleeve.

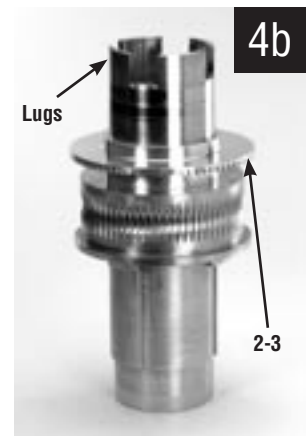

4.7.4 Optional Drive Sleeve and Baseplate Remounting

STEP 1

Assemble drive sleeve assembly with drive sleeve lying on opposite end of lugs. Place worm gear (#2-2), key (#2-6) and encoder drive gear (#2-3) onto the drive sleeve (#2-1). Place the ball bearing (#2-4) into the baseplate assembly. See picture 4b.

Lightly lubricate the bottom of the drive sleeve (#2-1) and the baseplate seal (#11-3).

Lift the drive sleeve assembly up, and holding the encoder drive gear (#2-2), turn the drive sleeve over and place into the baseplate assembly. See picture 4a.

STEP 2

With help, lift housing and place over the drive sleeve and baseplate assemblies. Match up the mounting holes in the baseplate and housing. With the actuator sitting on the baseplate, slide the unit over to the edge and mount one or two of the baseplate screws (#11-5). Turn unit over on its side with the drive sleeve horizontal and secure the baseplate with the rest of the mounting screws.

NOTE: The drive sleeve is held in from the top by the handwheel worm gear. Without the handwheel worm gear, the drive sleeve may slip out of position. Push the drive sleeve back into position from the handwheel worm gear end. See picture 3, 2, and 1, in that order from Section 4.7.3.

STEP 3

Remount all removed subassemblies according to their remounting instructions in the following order:

1. Base plate (subassembly #11). (See Section 4.5.2.)
2. Worm shaft (subassembly #3). (See Section 4.6.2.)
3. Handwheel declutch (subassembly #5). (See Section 4.2.2.)
4. Clutch and clutch ring (subassembly #16). (See Section 4.9.2.)
5. Handwheel worm gear (subassembly #12). (See Section 4.8.2.)
6. Side-mounted handwheel (subassembly #13). (See Section 4.3.2.)
7. Motor (subassembly #4). (See Section 4.1.2.)
8. Thrust base (subassembly #10) - if fitted. (See Section 4.7.2.)

4.8 Handwheel Worm Gear

Table 4.9 – Handwheel Worm Gear Assembly Parts List

Part Number	Description	Qty.
12-1	Handwheel Worm Gear	1
12-2	Ball Bearing	1
12-3	Quad Ring	1
12-4	O-ring	1

Figure 4.8 – Handwheel Worm Gear Assembly

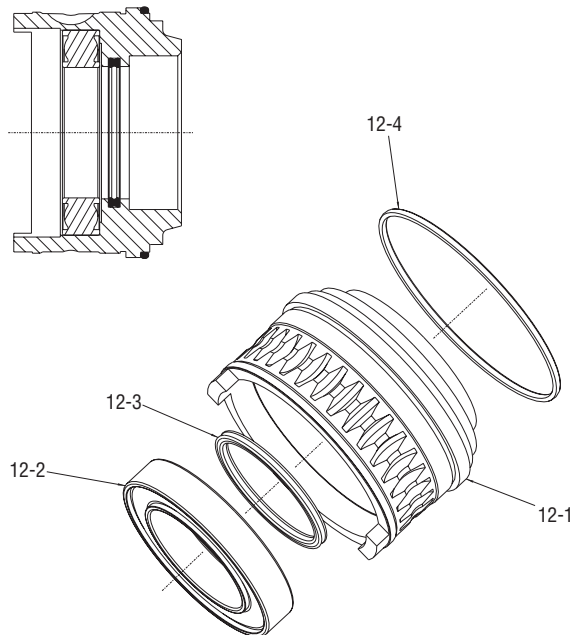

4.8.1 Removal

First Remove

1. Side-mounted handwheel (subassembly #13).
(See Section 4.3.1.)

NOTE: Before removing handwheel and handwheel worm gear assembly, turn handwheel approximately 45° to permit declutch lever to fully engage therefore making handwheel assembly easy to remove.



STEP 1

⚠ WARNING: Potential to operate while dangerous mechanical parts are exposed during subassembly removal. To prevent injury, turn off all power sources to actuator before removing handwheel worm gear assembly. Power sources may include main power or control power.

Remove the four screws (#1-33) from the retainer plate (#1-32).

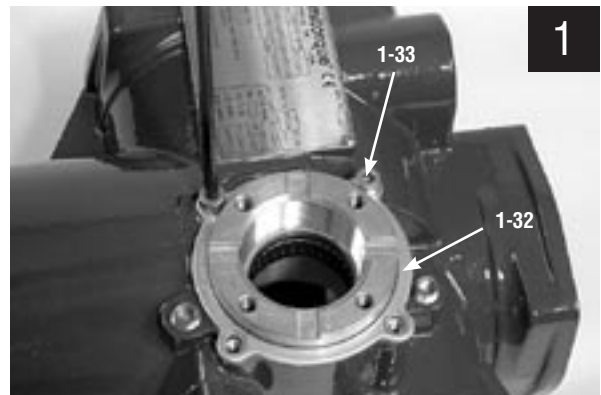

STEP 2

Lift off the retainer plate (#1-32).



STEP 3

Pull the handwheel worm gear assembly (#12) out of the actuator housing.

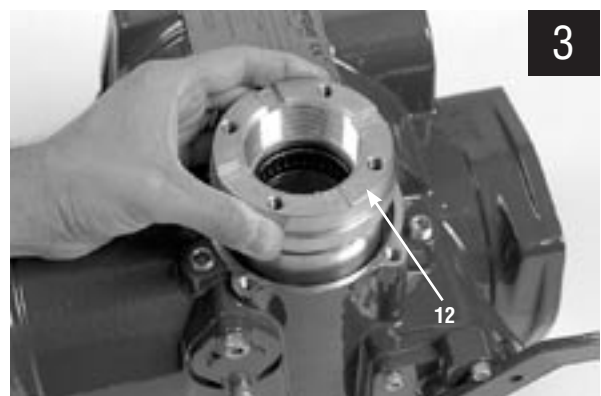

4.8.2 Remounting

STEP 4

NOTE: Lightly lubricate quad rings/O-rings before remounting subassemblies.

Fit the handwheel worm gear assembly (#12) into the top of the actuator housing. Slowly rotate the assembly as it approaches its lower position in the actuator; this will allow the quad ring (#12-3) to ease over the end of the drive sleeve avoiding damage to the quad ring.

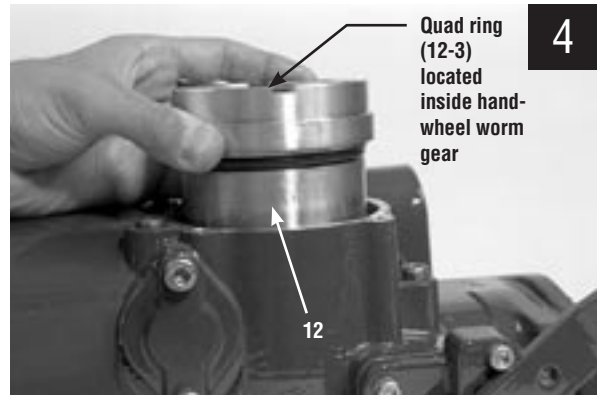

STEP 5

NOTE: Retainer plate (#1-32) may sit slightly above actuator housing until screws are retightened.

⚠ WARNING: The MX requires precaution to prevent damage to the declutch latch. This applies while installing the handwheel worm gear assembly (#1-35), retainer plate (#1-32) and screws (#1-33). If the unit is in the clutched position (handwheel operation) during assembly, a lug-to-lug condition can result between the clutch and the handwheel worm gear. In this situation the latch will be compressed and damaged when the plate screws are tightened.

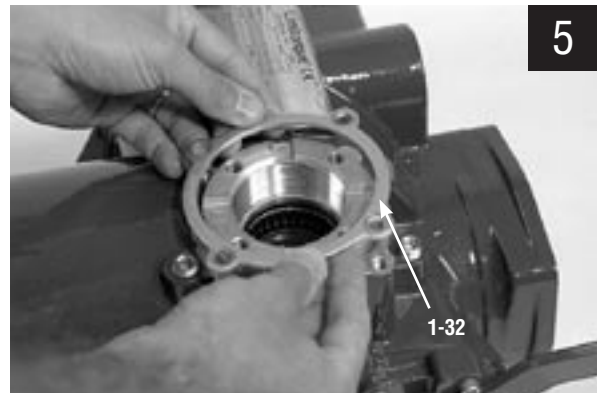

Assure the clutch lugs are fully engaged to the bronze gear lugs before installing the handwheel worm gear assembly. The latch must be rotated down and not holding the clutch off the bronze worm gear. When installing the handwheel worm gear, ensure these lugs fall between the clutch lugs. This position will allow the handwheel worm gear lugs to be fully engaged to the clutch lugs. The final step is to install the retaining plate and socket head cap screws.

Place the retainer plate (#1-32) on the top of the actuator housing. Align the mounting taps, and secure with screws (#1-33).

STEP 6

Install handwheel (#1-8) onto handwheel worm gear assembly (#12), align the handwheel with screw holes and tighten the four socket head cap screws (#1-11).

4.9 Clutch and Clutch Ring Components

Table 4.10 – Clutch and Clutch Ring Components Parts List

Part Number	Description	Qty.
1-38	Clutch	1
1-37	Clutch Ring	1
1-39	Clutch Spring	1
1-40	Spring Spacer	1

Figure 4.9 – Clutch and Clutch Ring Components

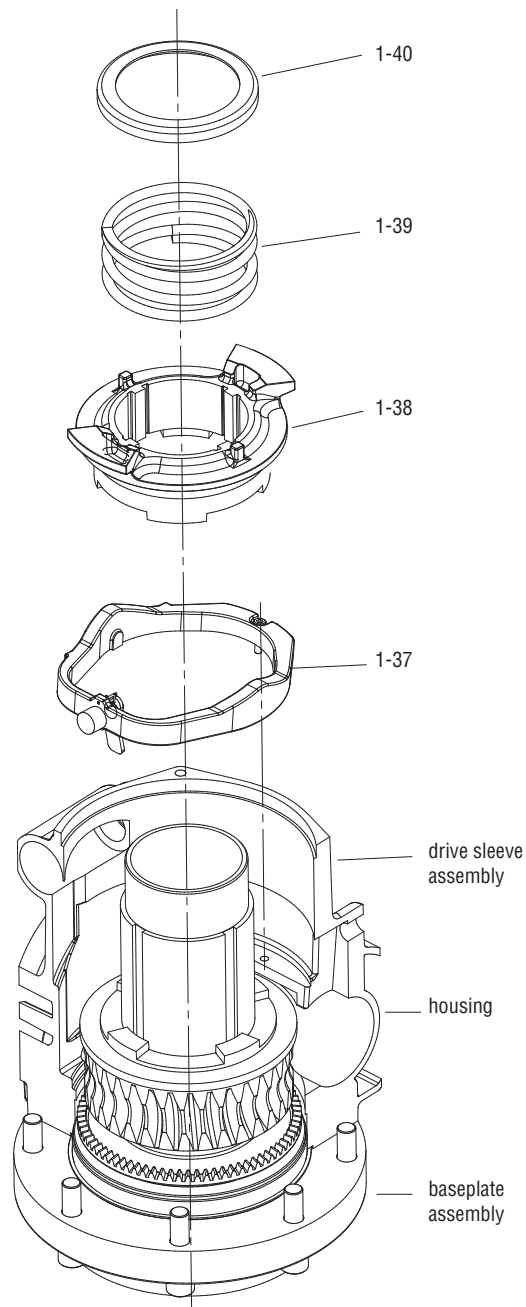

4.9.1 Removal

First Remove

1. Drain oil.
2. Remove side-mounted handwheel (subassembly #13). (See Section 4.3.1.)
3. Remove handwheel worm gear assembly (subassembly #12). (See Section 4.8.1.)

STEP 1

⚠ WARNING: Potential to operate while dangerous mechanical parts are exposed during subassembly removal. To prevent injury, turn off all power sources to actuator before removing clutch and clutch ring components. Power sources may include: main power or control power.

Remove spring spacer (#1-40).

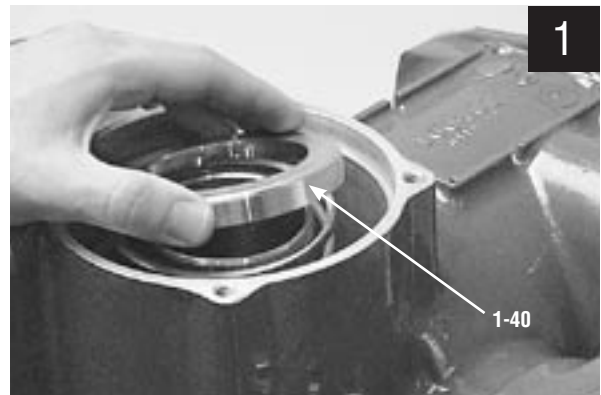

STEP 2

Remove clutch spring (#1-39) that is positioned over the drive sleeve assembly (#2).



STEP 3

Remove clutch (#1-38).



STEP 4

Remove clutch ring (#1-37).

While pulling up on clutch ring end with socket head cap screw (#15-9), rotate latch 90° and slide clutch ring over drive sleeve and out of housing.



4.9.2 Remounting

⚠ WARNING: Potential to operate while dangerous mechanical parts are exposed during subassembly removal. To prevent injury, turn off all power sources to actuator before removing clutch and clutch ring components. Power sources may include: main power or control power.

Table 4.11 – Clutch Ring Assembly Parts List

Part Number	Description	Qty.
15-1	Clutch Ring	1
15-2	Roller	1
15-3	Roll Pin	1
15-4	Spacer	1
15-5	Latch Spring	1
15-6	Roll Pin	1
15-7	Latch	1
15-8	Roll Pin	1
15-9	Socket Head Cap Screw	1

Figure 4.10 – Clutch Ring

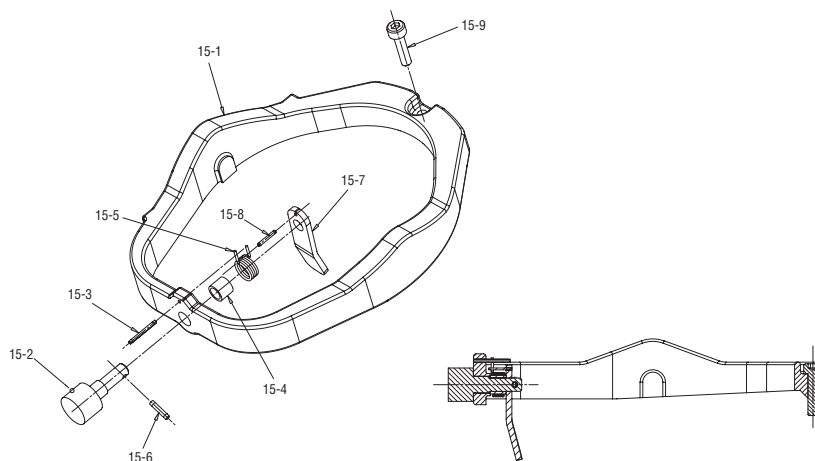

STEP 5

Fit the clutch ring (#1-37) over the drive sleeve. With the roller (#15-2) down and holding the latch (#15-7) 90° from free position. See 5a.

NOTE: The clutch ring socket head cap screw (#15-9) must fit into hole in housing to keep ring from rotating. See 5b. See Warning Note in Section 4.8.2, Step 5.

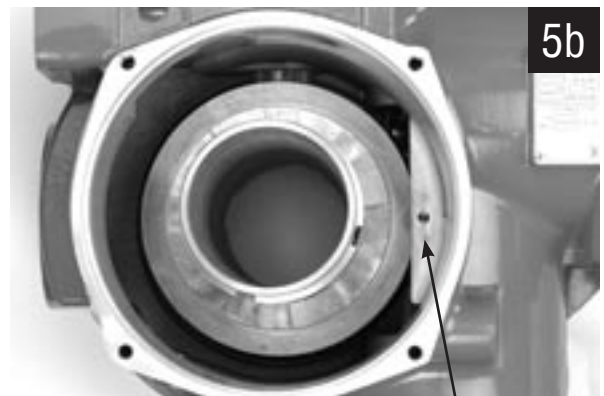

Housing hole for clutch ring screw for anti-rotation of clutch ring assembly

STEP 6

Slide clutch (#1-38) over drive sleeve assembly.



STEP 7

Slide spring (#1-39) over drive sleeve assembly.

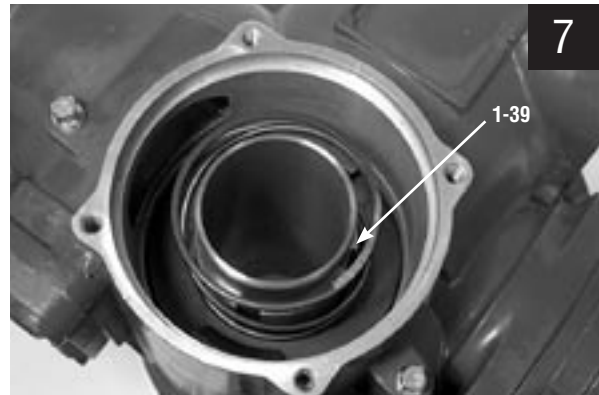

STEP 8

Slide spring spacer (#1-40) over drive sleeve assembly.

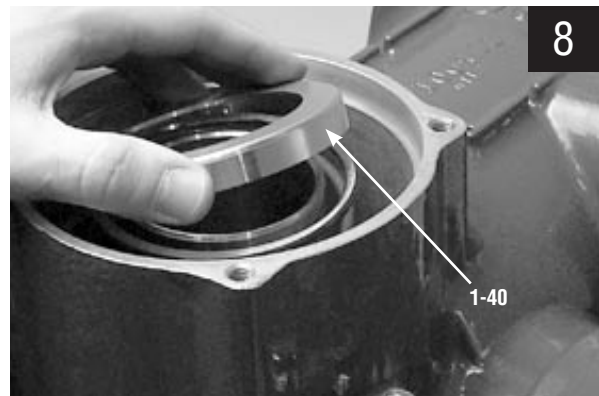

STEP 9

Remount removed subassemblies according to their remounting instructions in the following order:

1. Handwheel worm gear assembly (subassembly #12). (See Section 4.8.2.)
2. Side-mounted handwheel (subassembly #13). (See Section 4.3.2).

5

Electronic Assemblies

5.1 Accutronix Control Panel (ACP)

Table 5.1 – Accutronix Control Panel Parts List

Part Number	Description	Qty.
7-3	Black Knob	1
7-4	Red Knob	1
7-5	Brass Pin (not shown)	2
7-6	Self-Tapping Screw	2
7-7	Black Knob Cap	1
7-9	Extension Spring	1
7-10	Ball (not shown)	1
7-12	Torsion Spring	1
7-14	Red Knob Cap	1
7-19	O-ring Retainer	1
7-21	O-ring	1
7-23	Controls Cover	1
7-24	Window	1
7-25	Snap Ring	1
7-26	O-ring	1
7-27	Socket Head Cap Screw	4
8-24	PC Board	1
8-25	Pan Head Machine Screw (M4x6)	4

Figure 5.1 – Accutronix Control Panel

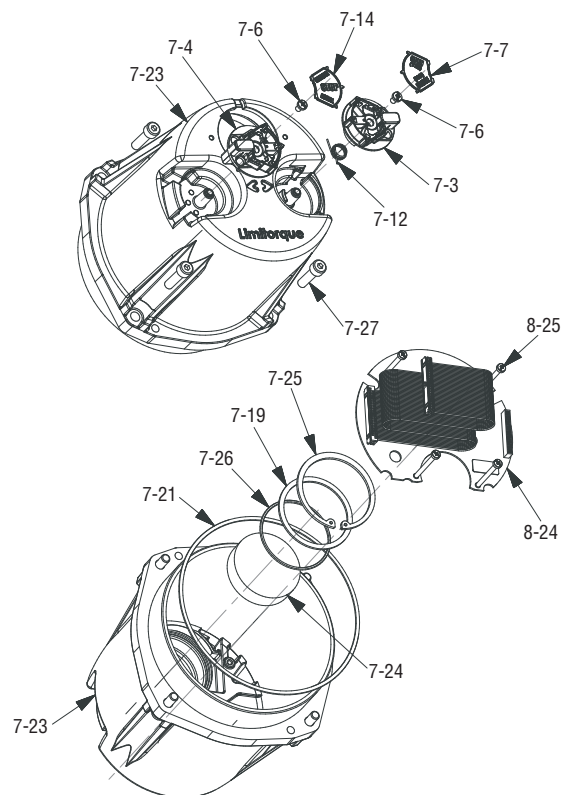

5.2 Installation and Removal of SMT Controls

5.2.1 Installation

STEP 1

▲ CAUTION: Ensure the voltage jumper on power board is located in the proper slot for the nameplate and motor voltage! Follow the template provided on the Mylar protection barrier for proper voltage jumper location.

▲ CAUTION: Potential to cause electrostatic damage to electronic components. Before handling electronic components, ensure that you are discharged of static electricity by briefly touching a grounded metal object. Flowserve recommends the use of a wrist strap grounded to an appropriate ground.



STEP 2 (IF NECESSARY)

Attach the SMT Terminal Block conversion wiring harness (P/N 64-825-0010-4) to the existing through hole wiring harness. Connect each through hole Molex connector to its corresponding SMT Molex connector.

STEP 3

Install tie wrap on the mated 20 pin Molex connector pair so that they cannot be separated.

STEP 4

Connect the 6-pin Molex wire harness to plug P2 and 16-pin Molex harness to plug P3, and the 20 pin Molex wire harness to plug P4 on Power board.



STEP 5

Position power assembly over the three mounting screw heads (#1-45). Rotate the subassembly in clockwise (CW) direction until all three screws are seated in the key slots. (The keyhole slots in the mounting plate (#8-1) are spaced in such a way that the control module assembly will mount in only one position).

Tighten the three screws (#1-45) with a 3 mm hex key.

**STEP 6**

Connect the AMP power connector to the fuse section on the Power board (P1).

**STEP 7**

Connect the 10-pin encoder ribbon cable to plug P3 on the Main/LCS processor board. Align the polarization plug with the slot in the center of connector J1.

**STEP 8**

Connect the 4-pin Molex harness to plug P4 on the Main/LCS processor board.

STEP 9

If DDC, Foundation Fieldbus H1 or Profibus DP/PA board is installed, stack the network board onto the Main/LCS board (or I/O option board) assuring proper mating of the board to board connector P1. Connect 10-pin Molex harness to plug P2 on these boards (network processor board).

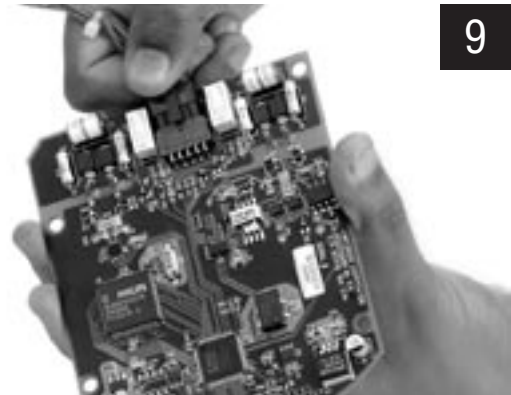

9

STEP 10

If I/O option board is installed, stack the I/O option board onto the Main/LCS board assuring proper mating of the board to board connector P2. Connect 24-pin Molex harness to plug P1 on I/O option board.

NOTE: If network or I/O option boards are installed, they may be stacked on the Main/LCS board in any order.



10

STEP 11

Before mounting the LCS/Main processor board into the ACP, replace the knobs per instructions #102254 (supplied with the knob conversion kit).

NOTE: Applies only to version 1 of ACP (V1 = triangle-shaped knobs)

Mount the LCS/Main processor board inside the ACP cover as follows:

STEP 12

Using a screwdriver, install the four M4 screws (#7-44) to retain the LCS/Main board inside the ACP cover. Select the screws based upon the number of option boards in the actuator; M4 X 6 mm for standard set, M4 X 25 mm for one option board, and M4 X 45 mm for two option boards.

Ensure O-ring (#7-21) is intact on the ACP spigot/pilot. Hold the ACP in front of the control module assembly and connect 40-pin ribbon connector plug to connector J1 on the power board. This ribbon cable is to always remain connected to the LCS/Main board. Align the polarization tab of the ribbon connector with the slot in J1.

STEP 13

▲ CAUTION: Potential to pinch cables. When remounting ACP cover, take special care not to pinch ribbon cables.

Dress the cables as shown being careful to position wires so that they pass perpendicularly over the housing flange.

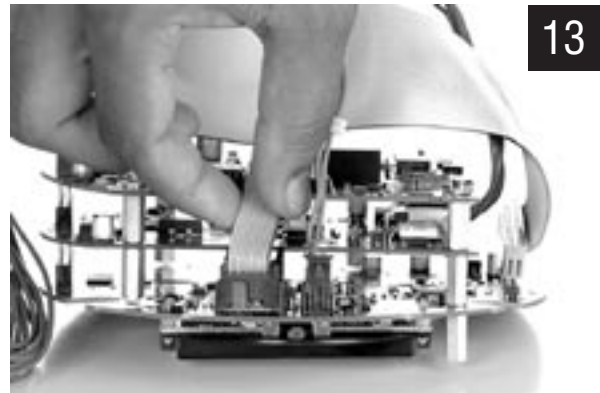

STEP 14

NOTE: The face of the ACP may be installed in any one of four 90° incremental positions. When changing ACP position, avoid over-twisting the ribbon cable.

Rotate the ACP until the display orientation of the front face is correct for normal viewing, then slide the ACP assembly into the actuator housing.



5.2.2 Removal

For removal, follow installation instructions in reverse.

5.2.3 Fuse Replacement

The view below shows the control module with the chassis assembly removed.

Figure 5.2: Location of Fuses and Voltage Jumper

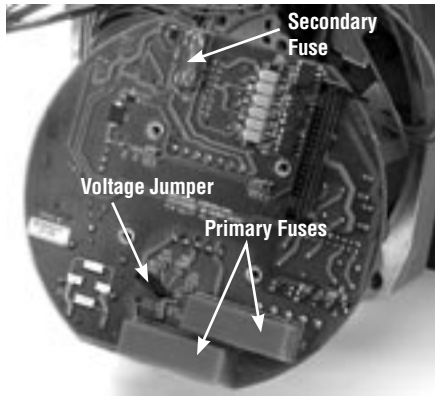

Primary Fuse

Remove plastic covers, fuses, and replace with 1A, 600V fuses.

Secondary Fuse

Remove plastic cover, fuse, and replace with 0.1A, 250V fuse

Voltage jumper selection

Remove and replace in proper slots according to nameplate voltage

5.2.4 Control Module Return Options

Please contact factory for return instructions.

5.3 Adding Electronic Options to Your Accutronix MX Actuator

Listed below are the options available for the Accutronix MX.

1. Modutronic option; does not require any hardware, however, a “keycode” from the factory is required.
2. Two-speed timer; does not require any hardware, however a “keycode” from the factory is required.
3. APT option; Analog Position Transmitter, non-contacting 4-20 mA position transmitter requiring the addition of the I/O (input/output) option board.
4. ATT option; Analog Torque Transmitter, non-contacting 4-20 mA torque transmitter requiring the addition of the I/O (input/output) option board.
5. AR option; Alarm Relays, three non-latching relays requiring the addition of the I/O (input/output) board. Non-latching relays change state when power is removed from the actuator, e.g. if the relay is CLOSED and power is removed, the relay will OPEN.
6. DDC option; network communication field board that is required for two-wire twisted pair, MODBUS communication.
7. FF option; network communications board required for Foundation Fieldbus communication.

The procedure for adding electronic options to your MX actuator is as follows:

- For adding the Modutronic and two-speed timer options, the actuator QA Stamp ID must be supplied in order to acquire the necessary keycode.
- Each MX actuator is supplied a unique “QA Stamp ID.” This number is assigned during the end-of-line test sequence for each unit.

- This serial number is located on the second screen after the “Restricted Settings” screen. It is an eight digit number after the letters “S/N”. Please refer to the IOM manual, LMAIM1306, supplied with your actuator for the Menu sequence.
- User must supply this number. Example: 12345678
- Also record the Order Number and Serial Number of the actuator. These numbers can be found on the unit nameplate.
- Once you have acquired the QA Stamp, O/N and S/N, please contact your assigned Service Coordinators for the keycodes required to turn-on the desired options @ (434) 528-4400.
- The “keycode” is then entered into the desired option menu found in “Restricted Settings” using the black knob on the ACP. A “NO” answer will change the value form 0-9 and A-E. A “YES” answer will truncate to the next space.
- After enabling the Modutronic option, please change the remote control wiring scheme to “3-wire maintained.”
- For adding the APT, ATT, and AR options, the I/O option board is required. When the I/O board is received and installed into the actuator, it will already have the option(s) enabled. The unit will recognize the board and turn on the required software menu feature. Please refer to the IOM manual, LMAIM1306, supplied with your actuator for the Menu sequence. The user will need to enable the menu options. Please contact your assigned Service Coordinators for purchase of these desired options @ (434) 528-4400.
- For adding the DDC or FF option, the DDC or FF option board is required. When the DDC option board is received and installed into the actuator, it will recognize the board and turn on the required software menu feature. Please refer to the IOM manual, LMAIM1306, supplied with your actuator for the Menu sequence. The user will need to enable the menu options. Please contact your assigned Service Coordinators for purchase of the DDC option @ (434) 528-4400.

5.4 Restoring Power to Actuator with New Control Module

Figure 5.3 – Restoring Power to Actuator with New Control Module

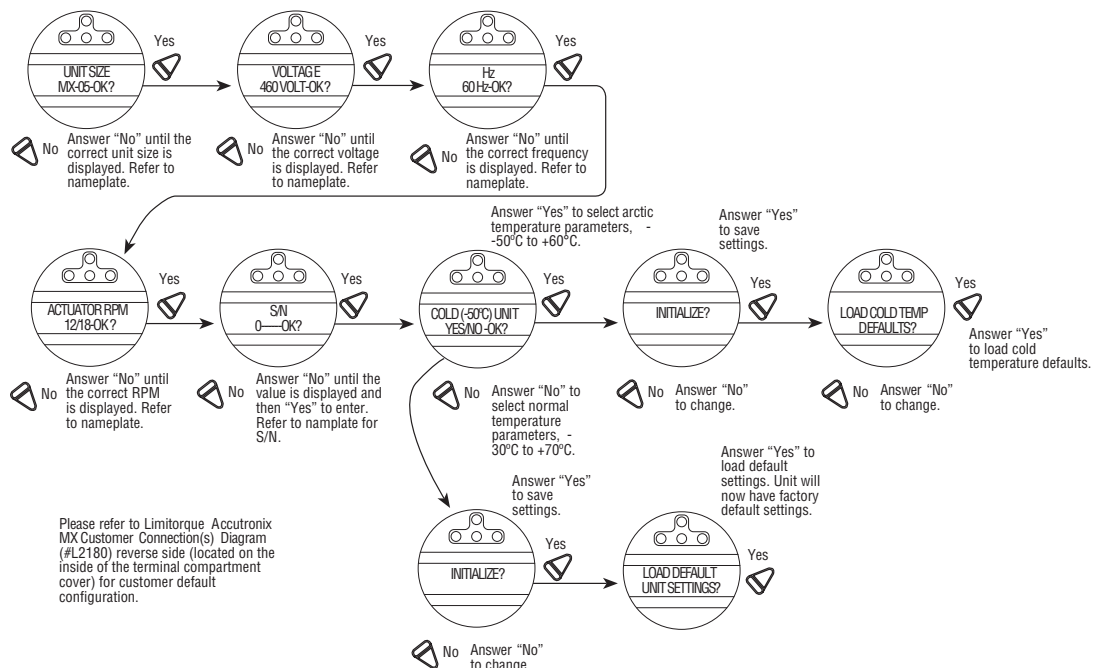

5.5 Terminal Block

Table 5.2 – Terminal Block Parts List

Part Number	Description	Qty.
1-20	O-ring	1
1-21	Retaining Ring	1
1-43	Pan Head (M3x4) Plastic Screw	2
8-15	Terminal Block	1
8-16	Self-Lock Combo Head Screw (M3x5)	48
8-17	Self-Lock Combo Head Screw (M5x8)	3
8-18	Cover Plate	1
8-19	Pan Head Self-Tapping Screw	2
8-20	Control Wiring Harness	1

Figure 5.4 – Terminal Block

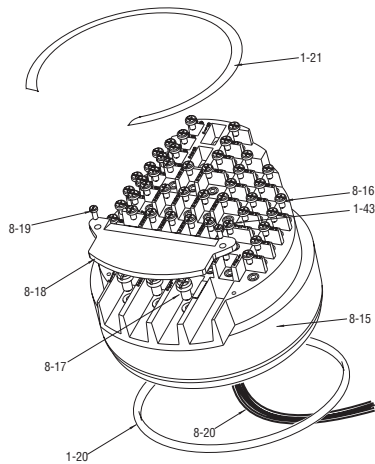

5.5.1 Removal

▲ CAUTION: Potential to cause electrostatic damage to electronic components. Before handling electronic components, ensure that you are discharged of static electricity by briefly touching a grounded metal object.

First Remove

1. Accutronix control panel (subassembly #7). (See Section 5.1.)
2. Control module (subassembly #8). (See Section 5.2.1.)

STEP 1

⚠ WARNING: Hazardous Voltage! Turn off all power sources to actuator before removing terminal block assembly. Power sources may include main power or control power.

Using an M6 hex key, remove the four M8 screws (#8-14) that mount the terminal compartment cover to the actuator.



STEP 2

If actuator is already in service, disconnect incoming power leads L1, L2, and L3 (and control wiring from the terminal block if terminal block replacement is required).



STEP 3

Using a flat head screwdriver, insert the screwdriver blade underneath the edge of the snap ring (#1-21) and work the blade around the back of the snap ring to remove it from the groove, thus allowing terminal block removal.

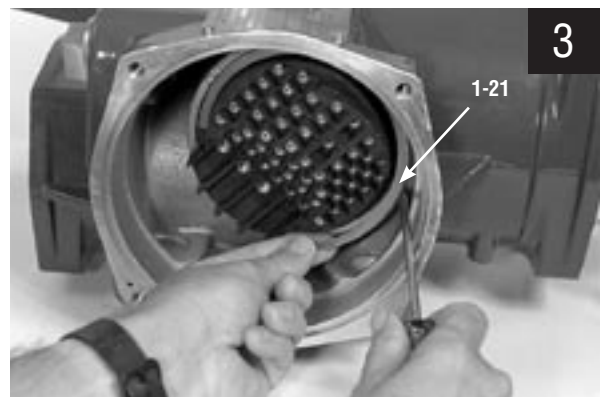

STEP 4

Remove terminal block assembly.

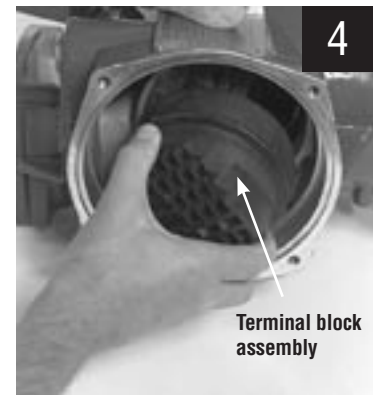
**STEP 5**

Disconnect leads L1, L2, and L3 from back of terminal block.

**STEP 6**

Feed the terminal block harness plugs over the contactor assembly (in the control module compartment) while removing the terminal block from the terminal block compartment. Notice an O-ring (#1-20) is included with the terminal block assembly. Ensure you retain or replace the O-ring at remounting.

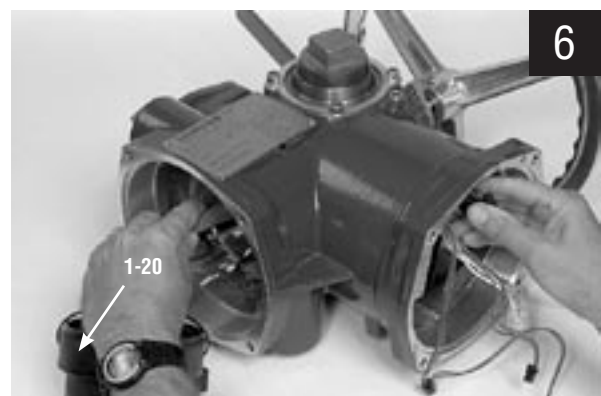

5.5.2 Remounting

STEP 7

⚠ **WARNING:** Hazardous Voltage! Turn off all power sources to actuator before remounting terminal block assembly. Power sources may include main power or control power.

If necessary, to allow terminal block wiring bundle to pass across the end of the contactor and into the controls compartment, use a M3 hex key to loosen the two 4 mm contactor screws (#8-28). Pull contactor assembly off the screws and lower assembly to create extra space for the wire harness to pass over the contactor and into the controls compartment.

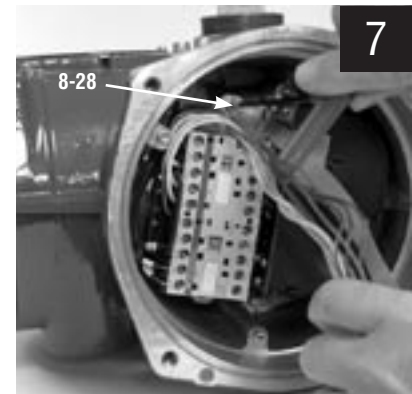

STEP 8

Plug power leads L1, L2, and L3 from contactor assembly into terminal connectors L1, L2, and L3 on back of terminal block. Verify that O-ring (#1-20) is installed on back of terminal block. Lightly lubricate O-ring before installing terminal block.

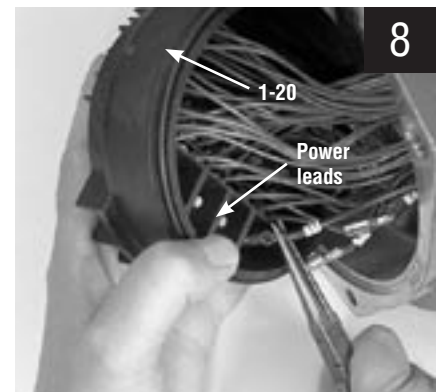

STEP 9

Insert terminal block into terminal block mounting cavity.



STEP 10

Insert retaining ring (#1-21) into retaining ring groove—snap retaining ring into groove by working a flat blade screwdriver around the edge of the retaining ring until it seats into groove.

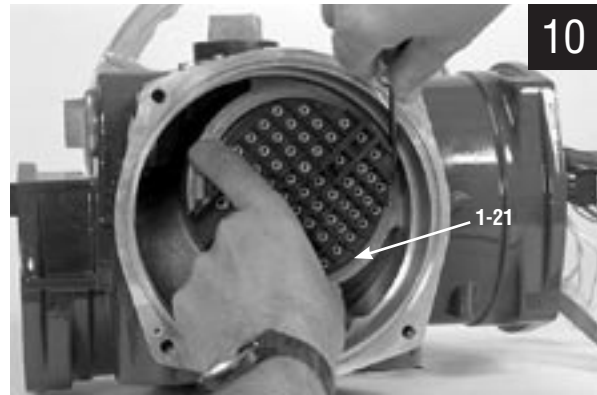
**STEP 11**

If contactor assembly was loosened in Step 7, then remount contactor on screws (#8-28). Retighten with M3 hex key.

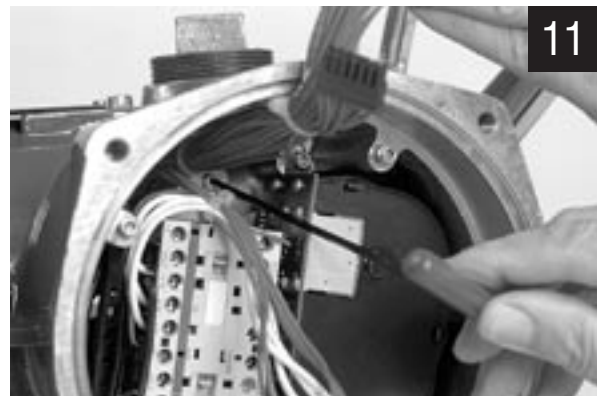
**STEP 12 AND 13**

Connect incoming power leads and control wiring according to application wiring diagram if terminal block has been replaced.

Install the terminal compartment cover and secure with four M8 screws using a 6 mm hex key.



5.6 Control Module—Contactor Assembly

Table 5.3 – Control Module—Contactor Assembly Parts List

Part Number	Description	Qty.
8-27	Contactor Bracket	1
8-28	Socket Head Cap Screw (M4x8)	1
8-29	Contactor Assembly	1

Figure 5.5 – Control Module – Contactor Assembly

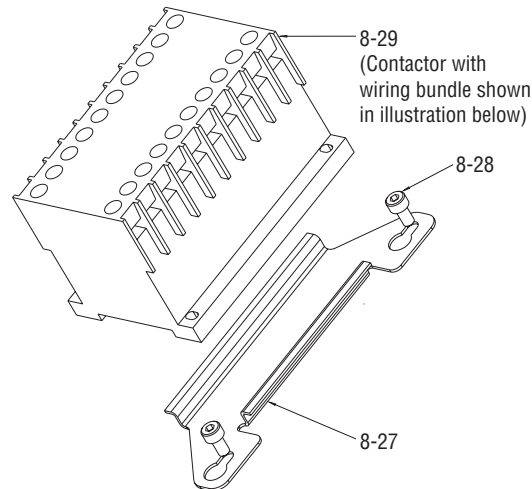
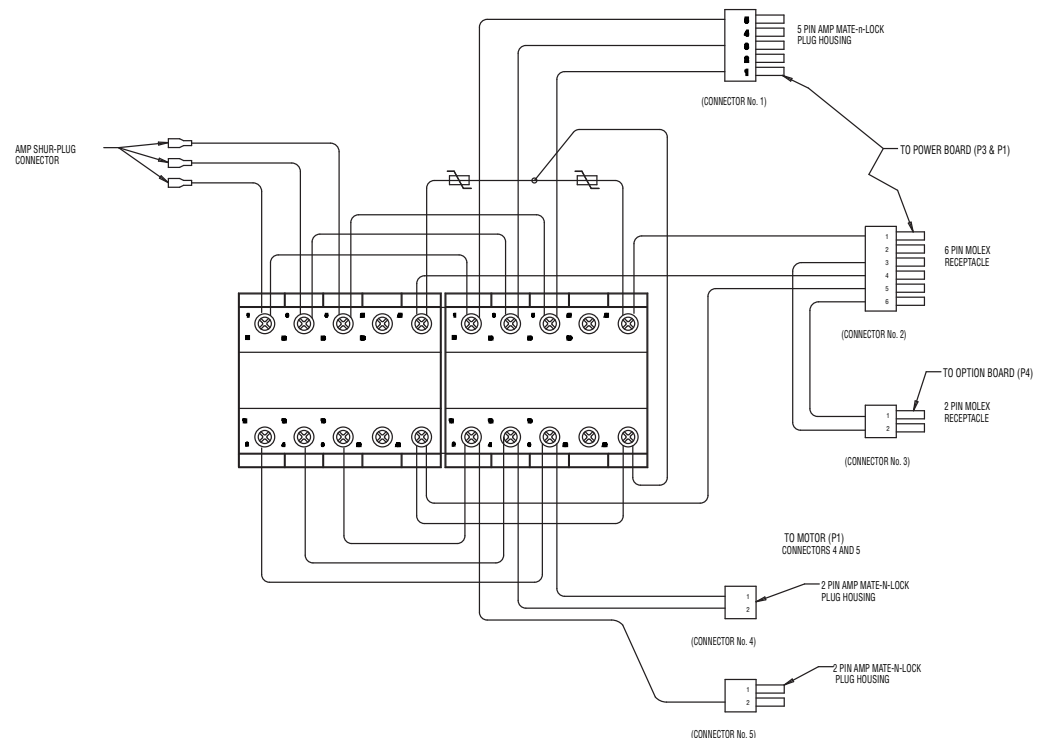

Figure 5.6 – Control Module – Contactor Assembly Wiring Diagram



5.6.1 Removal

First Remove

1. Remove motor (subassembly #4). (See Section 4.1.1.)
2. Remove Accutronix control panel (subassembly #7). (See Section 5.1.)
3. Remove control module (subassembly #8). (See Section 5.2.1.)
4. Remove terminal block (subassembly #15). (See Section 5.5.1.)

STEP 1

Using an M3 hex key, loosen the two 4 mm screws (#8-28) that mount the contactor assembly to the actuator.

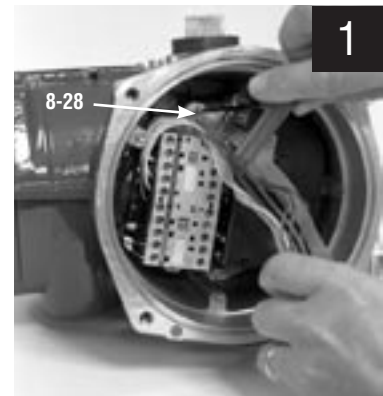

STEP 2

Lift contactor assembly until the keyhole slots in the contactor mounting plate allow the heads of the M4 screws to pass through.

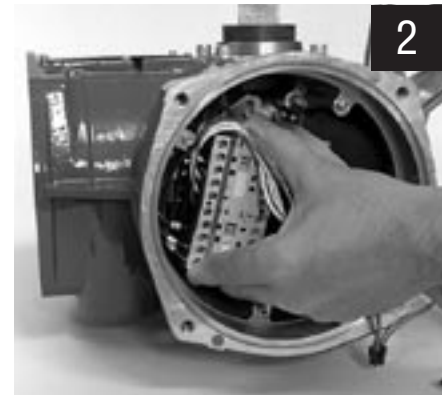

STEP 3

Remove the contactor assembly while threading the motor power socket out of the motor compartment.

Disconnect connectors 4 and 5 to motor lead harness.

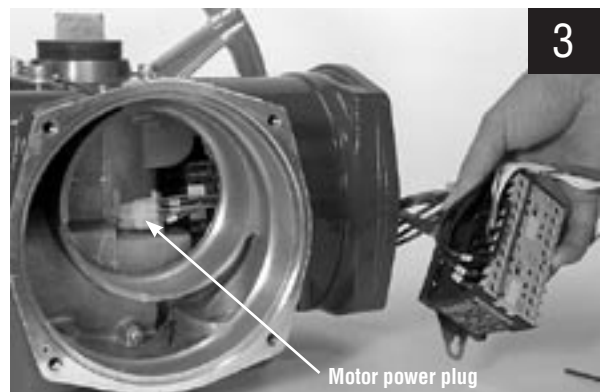

5.6.2 Remounting

STEP 4

Insert contactor assembly into control module cavity.

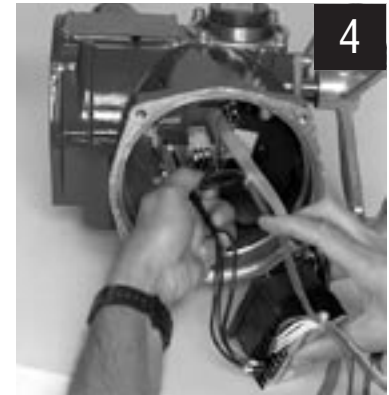

STEP 5

Route leads L1, L2, and L3 (input power) to the terminal block cavity.

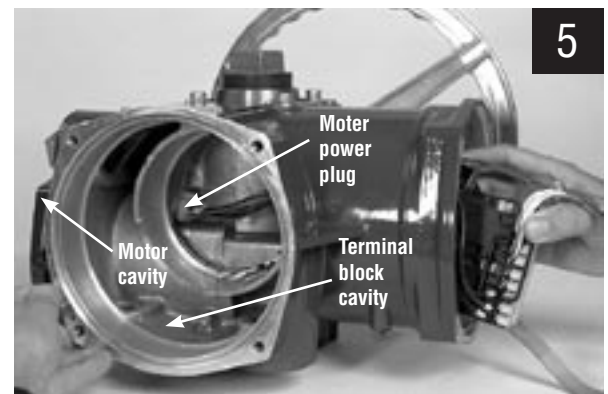

STEP 5A

Reconnect connectors 4 and 5 to motor lead harness.



STEP 6

Leave contactor assembly unmounted in control module compartment to allow space for terminal block harness plug bundle to be threaded over the top of the contactor assembly and pulled into the control module cavity.



STEP 7

Reference Terminal Block Assembly procedures to remount terminal block assembly into actuator. (See Section 5.5.2.)

Before mounting the contactor assembly, ensure the terminal block wiring harness bundle is positioned across the end of the contactor.

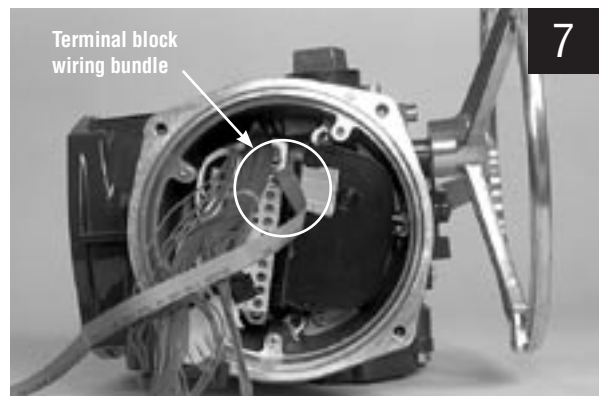

STEP 8

Position the contactor assembly so that the keyhole slots in the contactor mounting plate allow the M4 screw heads to pass through; shift the contactor assembly until the screw heads seat in the key slots. Tighten screws using 3 mm hex key to secure assembly.



STEP 9

Remount all removed subassemblies according to the remounting instructions in the following order:

1. Terminal block (subassembly #15).
(See Section 5.5.2.)
2. Control module (subassembly #8).
(See Section 5.2.2.)
3. Accutronix control panel (subassembly #7).
(See Section 5.1.)
4. Motor (subassembly #4). (See Section 4.1.2.)
If the motor voltage has changed, please see Section 5.2.2, Step 10 to ensure the voltage jumper on the power board is located in the proper slot.

5.7 Encoder

Table 5.4 – Encoder Parts List

Part Number	Description	Qty.
1-6	Encoder Assembly	1
1-36	Socket Head Cap Screw (M4x16)	3
6-11	Input Gear, 78-tooth (I.D. 3 through 7)	1
6-24	Input Gear, 69-tooth (I.D. 1 or 2)	1

Figure 5.7 – Encoder

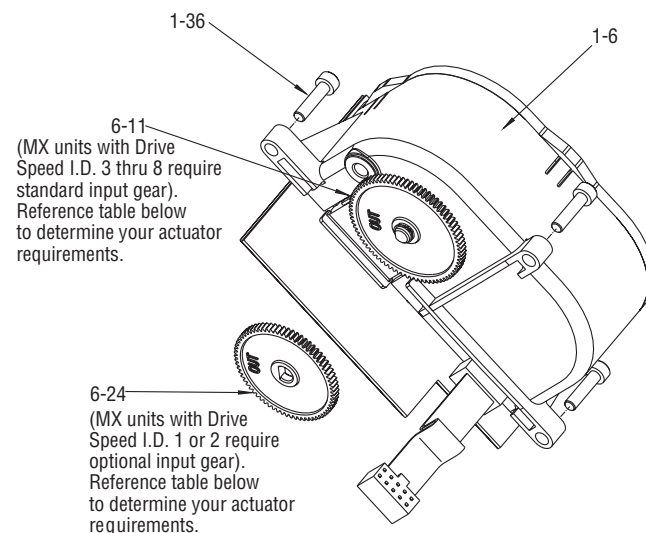

Table 5.5 – Encoder Drive Sleeve Speed (rpm)

Drive Sleeve Speed I.D.	1	2	3	4	5	6	7
50 Hz.	15	22	33	43	65	110	143
60 Hz.	18	26	40	52	77	131	170

NOTE: MX units with Drive Speed I.D. 1 or 2 require an optional input gear. Reference the Output RPM block located on the MX nameplate and cross-reference in table above to determine the unit Drive Speed I.D.

5.7.1 Removal

First Remove

⚠ CAUTION: Potential to cause electrostatic damage to electronic components. Before handling electronic components, ensure that you are discharged of static electricity by briefly touching a grounded metal object.

1. Remove Accutronix control panel (subassembly #7). (See Section 5.1.)
2. Remove control module (subassembly #8). (See Section 5.2.1.)

NOTE: The encoder is a sealed assembly of high-precision components and not suitable for repair. Should the encoder fail, it will be necessary to install a factory replacement.

STEP 1

⚠ WARNING: Hazardous Voltage! Turn off all power sources to actuator before removing encoder assembly. Power sources may include main power or control power.

⚠ CAUTION: To avoid accidental oil leakage when removing encoder screws (#1-36), be careful not to remove the encoder cartridge mounting screw (#14-8). The encoder cartridge screw is located near one of the encoder mounting screws. Accidentally removing the encoder cartridge mounting screw could cause oil leakage into the control compartment. (See Picture 1a.)

Remove the encoder by locating and removing the three M4 screws (#1-36) that mount the encoder to the actuator housing. Use a 3 mm hex key to remove the screws. (Reference Picture 1a to locate screws (#1-36); note important cautionary statement discussed with Step 1 and 1a).

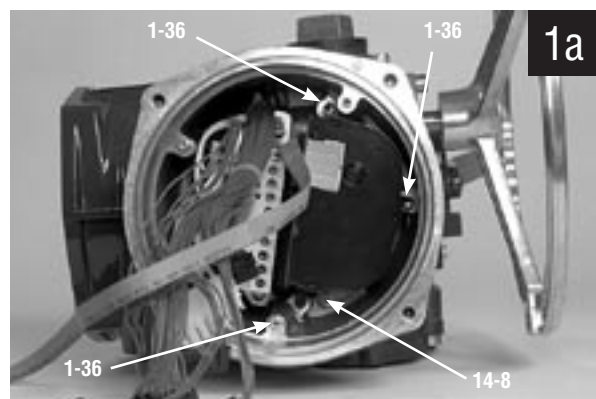
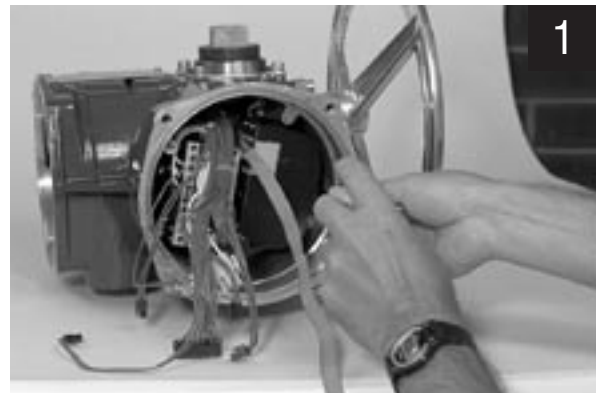

STEP 2

Pull the complete encoder straight out of the mounting holes to disengage the gear drive from the encoder drive cartridge pinion.



5.7.2 Remounting

STEP 3

⚠ WARNING: Hazardous Voltage! Turn off all power sources to actuator before remounting encoder assembly. Power sources may include main power.

If actuator uses drive sleeve speed I.D. 1 or 2, ensure optional encoder input gear (#6-24) is installed on encoder (see NOTE on page 5-24 for details). Align the three encoder mounting holes with the matching holes in the actuator housing and push the encoder straight on to the mounting boss, carefully positioning the encoder to ensure correct meshing with the encoder drive cartridge pinion. If needed to align gearing, declutch actuator and turn handwheel until encoder gear engages with drive cartridge pinion). Fit the three M4 screws (#1-36) and tighten using a 3 mm hex key. Do not overtighten.



5.8 Encoder Drive Cartridge

Table 5.6 – Encoder Drive Cartridge Parts List

Part Number	Description	Qty.
14-1	Encoder Drive Cartridge	1
14-2	Encoder Drive Shaft	1
14-3	Encoder Pinion	1
14-4	Ball Bearing	2
14-5	Oil Seal	1
14-6	Retaining Ring	1
14-7	Roll Pin	1
14-8	Socket Head Cap Screw	1
14-9	O-ring	1
6-25	Input Gear, 19-tooth	1

Table 5.7 – Encoder Drive Cartridge Drive Sleeve Speed

Drive Sleeve Speed I.D.	1	2	3	4	5	6	7
50 Hz. RPM	15	22	33	43	65	110	143
60 Hz. RPM	18	26	40	52	77	131	170

NOTE: Reference the Output RPM block located on the MX nameplate and cross-reference in table above to determine the unit Drive Speed I.D.

Figure 5.8 – Encoder Drive Cartridge

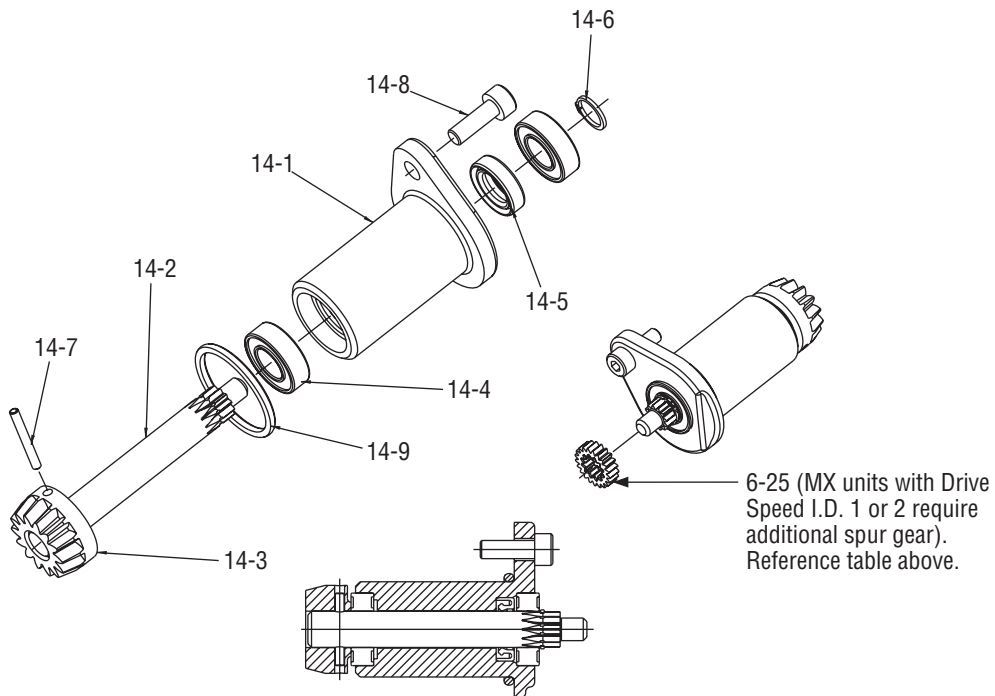

5.8.1 Removal

First Remove

1. Drain oil.
2. Remove ACP cover (subassembly #7). (See Section 5.1.)
3. Remove control module (subassembly #8). (See Section 5.2.1.)
4. Remove encoder (subassembly #6). (See Section 5.7.1.)

STEP 1

- ⚠ **WARNING:** Hazardous Voltage! Turn off all power sources to actuator before removing encoder drive cartridge. Power sources may include main power or control power.

Remove the M4 screw (#14-8) using a 3 mm hex key.

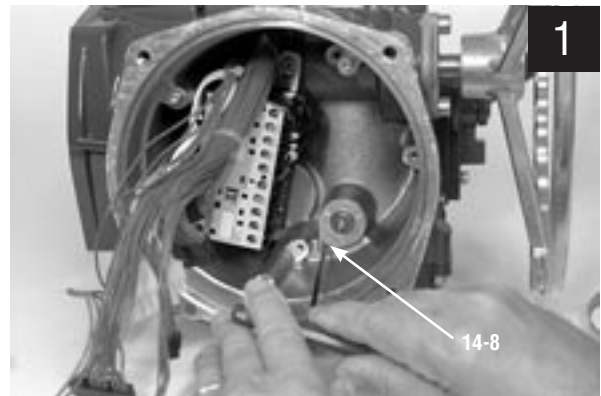

STEP 2

Withdraw the complete encoder drive cartridge from the actuator housing.

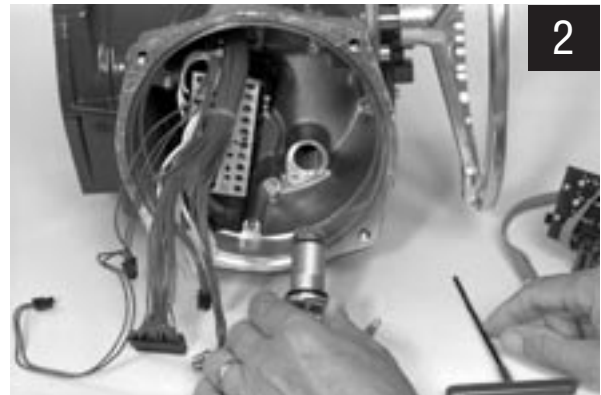

5.8.2 Remounting

STEP 3

If actuator uses drive sleeve speed I.D. 1 or 2, ensure input gear (#6-25) is installed on encoder (see NOTE on page 5-28 for details). Fit the encoder drive cartridge into the actuator housing.

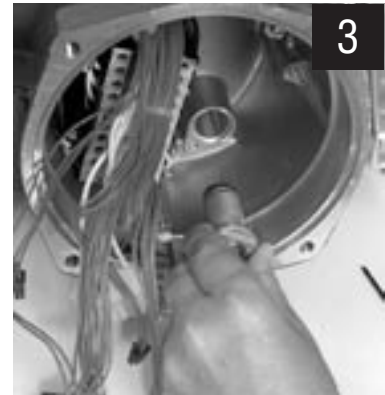

STEP 4

Using a 3 mm hex key, fit the M4 screw (#14-8) into the actuator housing to secure the encoder cartridge.



5.9 Motor Lead Harness

Figure 5.9 – Motor Lead Assembly

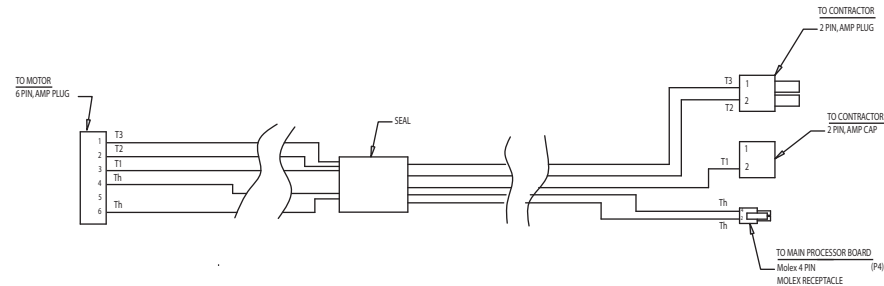

5.9.1 Removal

First Remove

1. Remove motor (subassembly #4). (See Section 4.1.1)
2. Remove Accutronix control panel (subassembly #7). (See Section 5.1.)
3. Remove control module (subassembly #15). (See Section 5.2.1)
4. Remove contactor assembly (subassembly #8). (See Section 5.6.1)

STEP 1

If worm shaft assembly (subassembly #3) is still mounted in unit, remove the four screws (#3-9) and rotate cap (CCW) to rotate cap tab away from motor lead seal.

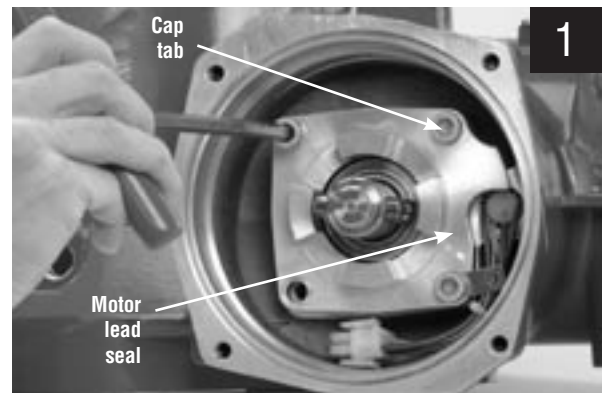

STEP 2

Remove motor lead harness by threading the harness back through housing and out motor end. Work the three connectors out through the hole/slot in the housing one at a time.



5.9.2 Remounting

STEP 3

Work the three connectors through the hole/slot in the housing. (Hole/slot is located in the motor cavity next to the worm shaft bore.) Thread the three connectors through the housing into the controls compartment cavity until the lead seal fits completely into the hole/slot in the housing.



STEP 4

Remount all removed subassemblies according to the remounting instructions in the following order.

1. Contactor assembly (subassembly #8).
(See Section 5.6.1)
2. Control module (subassembly #15).
(See Section 5.2.1)
3. Accutronix control panel (subassembly #7).
(See Section 5.1.)
4. Motor (subassembly #4). (See Section 4.1.1)

6

Spare and Replacement Parts

6.1 Guidelines for Recommended Spare Parts

Since every Limitorque actuator is designed to meet a specific application, the recommended spare parts needed to support the actuator will vary for every project. The following guidelines are provided to assist in determining the specific spare parts requirements for your Limitorque MX actuators.

6.1.1 Wear Components

The following components will eventually wear under normal use and should therefore be planned as spares. The expected lifetime of these parts will vary from application to application. They are listed in order of most frequent to least frequent replacement. Limitorque recommends stock levels of between 5% and 10% of the total population of each part with a minimum of 1 of each in order to support the product for life.

1. Stem Nut
2. Worm Shaft subassembly
3. Drive Sleeve subassembly

6.1.2 Bearings, O-rings and Seals

All bearings should be replaced any time an actuator is refurbished. Therefore, all bearings should be planned for stock for any scheduled refurbishment. In addition, any O-ring or seals should be replaced anytime an actuator is disassembled. Complete actuator seal kits are available for MX-85/140. Limitorque recommends stock levels for seal kits of 10% of the total population of each actuator model and size. Also, an adequate supply of Limitorque approved oil (Mobil SHC-632) should be maintained in stock to support any necessary maintenance or refurbishment.

6.1.3 Critical Components

The following parts are not subject to wear but are still recommended for stock due to their critical nature. Limitorque recommends stock levels of between 5% and 10% of the total population of each part with a minimum of 1 of each in order to support the product for life.

1. Motor
2. Encoder
3. Control Module

6.2 Recommended Spare Parts for MX Actuators

6.2.1 Commissioning and Startup

No additional spare parts are required. All necessary spares are included in the end-user bag.

6.2.2 Short-Term Duty

This is defined as up to 3000 seats or up to 1 million drive sleeve turns, whichever occurs sooner. There are no spare parts required for the actuator during short-term duty.

6.2.3 Long-Term Duty

This is defined as service beyond short-term duty but less than 6000 seats and less than 1.5 million drive sleeve turns. The spares suggested for long-term duty are as follows:

- Quad rings at the top and bottom of the drive sleeve
- Drive sleeve assembly which includes the Worm Gear
- Wormshaft assembly
- Encoder Cartridge assembly
- Motor assembly
- Fuse (Controls, quantity 1)
- Fuses (Power, quantity 2)
- Encoder assembly
- Reversing Starter/Contactor with harness
- Control Module (includes PCB-power, main, ACP, and optional DDC and I/O boards)
- Bronze drive sleeve for thrust base
- Quad rings in thrust base
- Quad rings in B1 base

NOTE: Oil should be changed every 6000 seats or sooner if the oil has been contaminated with water or other foreign material.

6.2.4 Severe Duty

This is defined as open/close service when run loads exceed 30% of the unit rating. This also includes all modulating applications.

NOTE: Oil should be changed every 3000 seats for open close service, or sooner if the oil has been contaminated.

The spares suggested for severe duty are identical to the long-term duty spares.

6.3 Other Concerns

There are other unique application requirements that may result in additional parts being added to the list of recommended spares. Some additional issues or requirements that should be considered when determining required spare parts include (but are not limited to):

1. Maintenance Program
2. Frequency of operation
3. Modulating duty
4. Frequent operation by handwheel
5. Regular testing
6. Stall/overload condition

Limitorque strongly recommends using OEM parts to support and maintain your Limitorque actuator. Installing parts other than genuine Limitorque parts could cause premature failure of your Limitorque actuator and voids any remaining warranty.

The above guidelines are provided to assist you in determining your unique spare parts needs. Please contact your local Limitorque Sales Office or local Au-tho-rized Stocking Distributor for additional help in evaluating your needs.

This page is intentionally blank.

7

Regulatory Information

7.1 Declaration of Conformity

Application of Council Directive(s)

89/336/EEC; EMC Directive
98/37/EEC; Machinery Directive

Standard(s) to which Conformity is Declared

Machinery; EN 60204 EMC
EMC; EN 50081-1 & 2
Applicable Emissions Standards; EN 50011:1998

- Radiated emissions; EN 55011:1998 & FCC Part 15, subpart J
- Conducted emissions; EN 55011:1998 & FCC Part 15, subpart J

 Applicable Immunity Standards;

- IEC EN 61000-6-1:2001
- ESD; IEC 61000-4-1:1995
- Radiated RF Immunity; IEC 61000-4-3:1995
- Fast Transients and Bursts; IEC 61000-4-4:1995
- Voltage Surges; IEC 61000-4-5:1995
- Conducted RF Immunity; IEC 61000-4-6:1996
- Magnetic Field Immunity; IEC 61000-4-8:1993
- Voltage Dips and Interrupts; IEC 61000-4-11:1994

Manufacturer's Name

Limitorque

Manufacturer's Address

5114 Woodall Road
Lynchburg, VA 24502

Importer's Name

Limitorque

Importer's Address

Abex Road
Newbury
Berkshire, RG14 5EY
England

Type and Description of Equipment

Valve Actuators

Model Number

MX Series

Note

Tested with Limitorque products only

I, the undersigned, hereby declare that the equipment specified above conforms to the above Directive(s) and Standard(s). List as follows:



(Signature)

Barry Morse

(Full Name)

Internal Sales Manager

(Title)

Newbury, England

Place

November 1, 1999

Date

This page is intentionally blank.

This page is intentionally blank.

This page is intentionally blank.



Flowserve Corporation has established industry leadership in the design and manufacture of its products. When properly selected, this Flowserve product is designed to perform its intended function safely during its useful life. However, the purchaser or user of Flowserve products should be aware that Flowserve products might be used in numerous applications under a wide variety of industrial service conditions. Although Flowserve can (and often does) provide general guidelines, it cannot provide specific data and warnings for all possible applications. The purchaser/user must therefore assume the ultimate responsibility for the proper sizing and selection, installation, operation, and maintenance of Flowserve products. The purchaser/user should read and understand the Installation Operation Maintenance (IOM) instructions included with the product, and train its employees and contractors in the safe use of Flowserve products in connection with the specific application.

While the information and specifications contained in this literature are believed to be accurate, they are supplied for informative purposes only and should not be considered certified or as a guarantee of satisfactory results by reliance thereon. Nothing contained herein is to be construed as a warranty or guarantee, express or implied, regarding any matter with respect to this product. Because Flowserve is continually improving and upgrading its product design, the specifications, dimensions and information contained herein are subject to change without notice. Should any question arise concerning these provisions, the purchaser/user should contact Flowserve Corporation at any one of its worldwide operations or offices.

For more information about Flowserve Corporation, visit www.flowserve.com or call USA 1-800-225-6989.



Limatorque
5114 Woodall Road, P.O. Box 11318
Lynchburg, VA 24506-1318
Phone: 434-528-4400
Facsimile: 434-845-9736
www.limatorque.com

Limatorque
Abex Road
Newbury
Berkshire, RG14 5EY
England
Phone: 44-1-635-46999
Facsimile: 44-1-635-36034

Limatorque Nippon Gear Co., Ltd.
Asahi-Seimei Bldg. 4th Floor
1-11-11 Kita-Saiwai, Nishi-Ku
Yokohama-Shi, (220-0004)
Japan
Phone: 81-45-326-2065
Facsimile: 81-45-320-5962

Limatorque India, Ltd.
15/4, Mile Stone
Mathura Road
Faridabad 121002
India
Phone: 91-129-2276586
Facsimile: 91-129-2277135

Flowserve Australia, Pty. Ltd.
14 Dalmore Drive
Scoresby, Victoria 3179
Australia
Phone: 61 3 9759 3300
Facsimile: 61 3 9759 3301

Limatorque Asia, Pte., Ltd.
12, Tuas Avenue 20
Singapore 638824
Phone: 65-6868-4628
Facsimile: 65-6862-4940