



## *Flowserve RF Butterfly Valves Flanged Rubber Seated*



*Experience In Motion*

## RF Butterfly Valves

FLOWERVE RF FLANGED BUTTERFLY VALVES meet the specifications of AWWA C504. Our single design allows all components to be standardized for your convenience and flexibility. We offer a size range of 350 mm (14in.) to 2600 mm (104 in). The heavy duty construction is designed for dependability and long term service.

We offer the following features in our valves:

- The bubble tight 360° rubber ring seal is set at the factory to assure a positive seal. A final leak test confirms tightness of the seal
- Replaceable body seat - Rubber seat vulcanized to a metal ring (350 mm-1000 mm) may be easily replaced if necessary by removing the retaining ring
- Reduced maintenance - The double eccentric design offers long service life

### General Specifications

Sizes...350 mm (14 in) to 2600 mm (104 in)

Maximum Working Pressure ..... 10 bar (150 psi)

Shell Test Pressure (For Body) ..... 20 bar (300 psi)

Seat Test Pressure ..... 10 bar (150 psi)

Valves with seats in Viton are limited to 6 bar (90 psi) maximum pressure

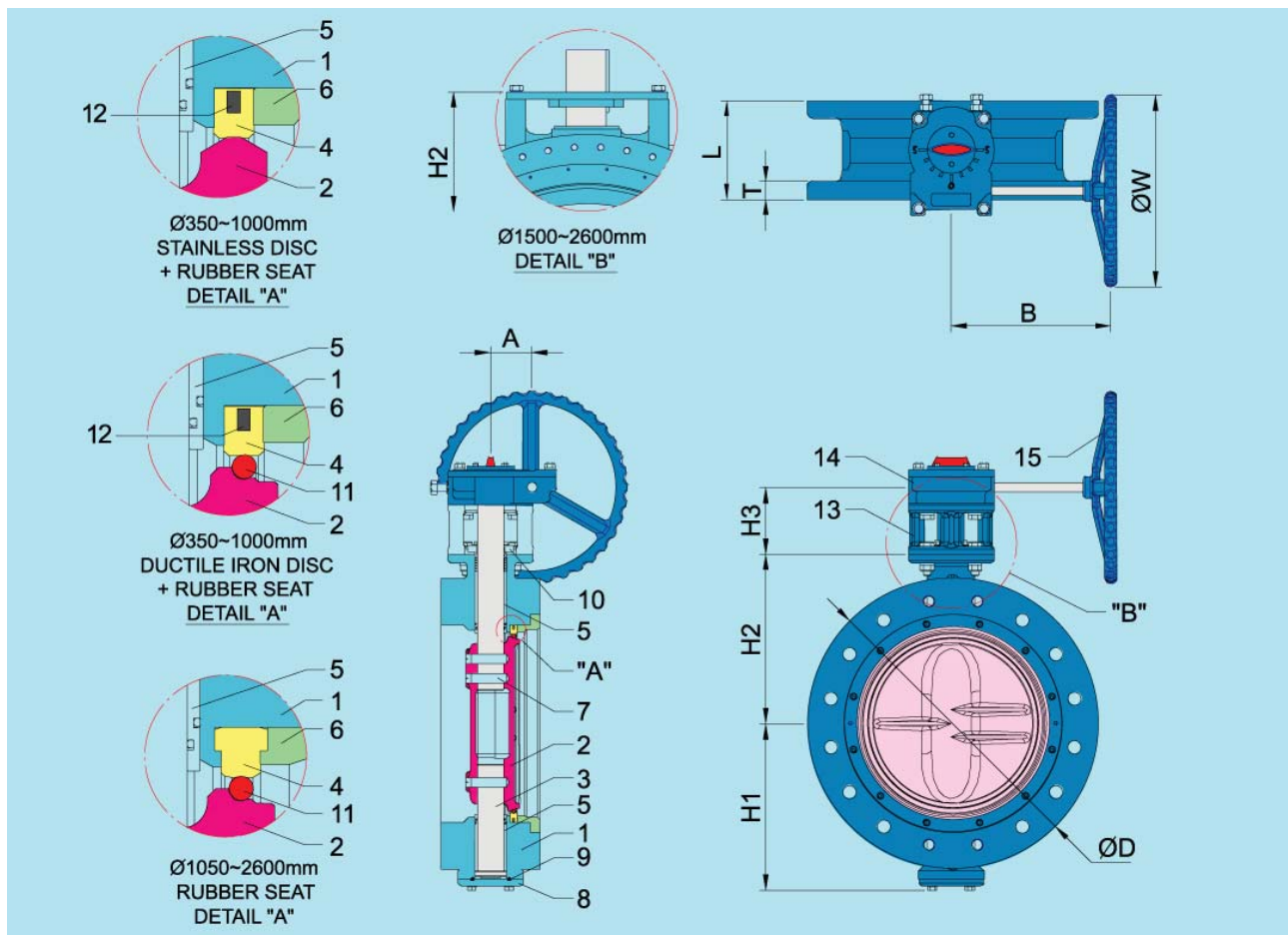

## Standard Materials

No.	Name	Materials	Specification	
			JIS	ASTM
1	Body	Cast Iron	FC200	A126-B
		Ductile Iron	FCD400	A395
2	Disc	Ductile Iron	FCD400	A395
		Stainless Steel	SCS13A SCS14A	A351 CF8 A351 CF8M
3	Stem	Stainless Steel	SUS410	A182 F410
4	Seat	NBR (Nitrile)		
		EPDM		
		Neoprene (CR)		
		Viton		
5	Bushing	Bronze	BC6	B62
6	Seat Ring	Ductile Iron	FCD400	A395
7	Pin	Stainless Steel	SUS410	A182 F410
8	Bottom Cover	Cast Iron	FC200	A126-B
9	Stem Seal	NBR (Nitrile)		
10	Gland	Bronze	BC6	B62
11	Disc Edge Ring	Stainless Steel	SUS304	A182 F304
12	Metal Ring	Steel	SS400	A36
13	Yoke	Ductile Iron	FCD450	A536-65-45-12
14	Gear Operator	Ductile Iron	FCD450	A536-65-45-12
15	Handwheel	Ductile Iron	FCD450	A536-65-45-12

Note: Body, disc, stem are available in super duplex stainless steel

## Temperature Guide

NBR (Nitrile)	14°F to 176°F (-10°C to 80°C)
EPDM	-4°F to 248°F (-20°C to 120°C)
Neoprene (CR)	32°F to 176°F (0°C to 80°C)
Viton	0°F to 400°F (-18°C to 204°C)

## Applicable Standards

Valve Design	Reference Standard
Valve design	AWWA C504
Valve flange design	AWWA C207 Class E Table 4
Face to face dimensions	AWWA C504 short body
Mounting flange dimensions	ISO 5211
Hydraulic test	AWWA C504

## Dimensions

SIZE		L		ØD		H1		H2		H3		T		A		B		ØW	
mm	in	mm	in	mm	in	mm	in	mm	in	mm	in	mm	in	mm	in	mm	in	mm	in
350	14	203	8.0	535	21.1	302	11.9	305	12.0	152	6.0	35	1.4	81	3.2	280	11.0	400	15.7
400	16	203	8.0	597	23.5	332	13.1	326	12.8	152	6.0	37	1.5	81	3.2	280	11.0	400	15.7
450	18	203	8.0	640	25.2	366	14.4	395	15.6	206	8.1	40	1.6	123	4.8	307	12.1	400	15.7
500	20	203	8.0	700	27.6	391	15.4	400	15.7	206	8.1	43	1.7	123	4.8	307	12.1	400	15.7
600	24	203	8.0	815	32.1	449	17.7	455	17.9	206	8.1	45	1.8	123	4.8	307	12.1	400	15.7
700	28	305	12.0	927	36.5	549	21.6	552	21.7	295	11.6	48	1.9	160	6.3	370	14.6	400	15.7
750	30	305	12.0	985	38.8	551	21.7	575	22.6	295	11.6	54	2.1	160	6.3	370	14.6	400	15.7
800	32	305	12.0	1060	41.7	602	23.7	616	24.3	295	11.6	55	2.2	160	6.3	370	14.6	400	15.7
900	36	305	12.0	1170	46.1	632	24.9	690	27.2	346	13.6	60	2.4	197	7.8	471	18.5	600	23.6
1000	40	305	12.0	1289	50.7	734	28.9	789	31.1	346	13.6	64	2.5	197	7.8	471	18.5	600	23.6
1050	42	305	12.0	1347	53.0	733	28.9	789	31.1	346	13.6	67	2.6	197	7.8	471	18.5	600	23.6
1100	44	305	12.0	1405	55.3	773	30.4	800	31.5	346	13.6	67	2.6	197	7.8	471	18.5	600	23.6
1200	48	381	15.0	1512	59.5	822	32.4	880	34.6	310	12.2	70	2.8	247	9.7	564	22.2	600	23.6
1350	54	381	15.0	1683	66.3	880	34.6	966	38.0	310	12.2	76	3.0	247	9.7	564	22.2	600	23.6
1500	60	381	15.0	1854	73.0	998	39.3	1100	43.3	161	6.3	79	3.1	330	13.0	736	29.0	600	23.6
1600	64	381	15.0	1785	70.3	1203	47.4	1130	44.5	161	6.3	65	2.6	330	13.0	736	29.0	600	23.6
1650	66	457	18.0	2032	80.0	1078	42.4	1185	46.7	161	6.3	86	3.4	330	13.0	736	29.0	600	23.6
1800	72	457	18.0	2197	86.5	1177	46.3	1280	50.4	314	12.4	89	3.5	336	13.2	859	33.8	600	23.6
2000	78	508	20.0	2362	93.0	1277	50.3	1380	54.3	314	12.4	99	3.9	336	13.2	859	33.8	600	23.6
2200	88	580	22.8	2642	104.0	1397	55.0	1500	59.1	314	12.4	89	3.5	336	13.2	859	33.8	600	23.6
2400	96	580	22.8	2877	113.3	1555	61.2	1615	63.6	221	8.7	108	4.3	554	21.8	1204	47.4	600	23.6
2600	104	580	22.8	3048	120.0	1596	62.8	1700	66.9	221	8.7	117	4.6	554	21.8	1204	47.4	600	23.6

## Mounting Details

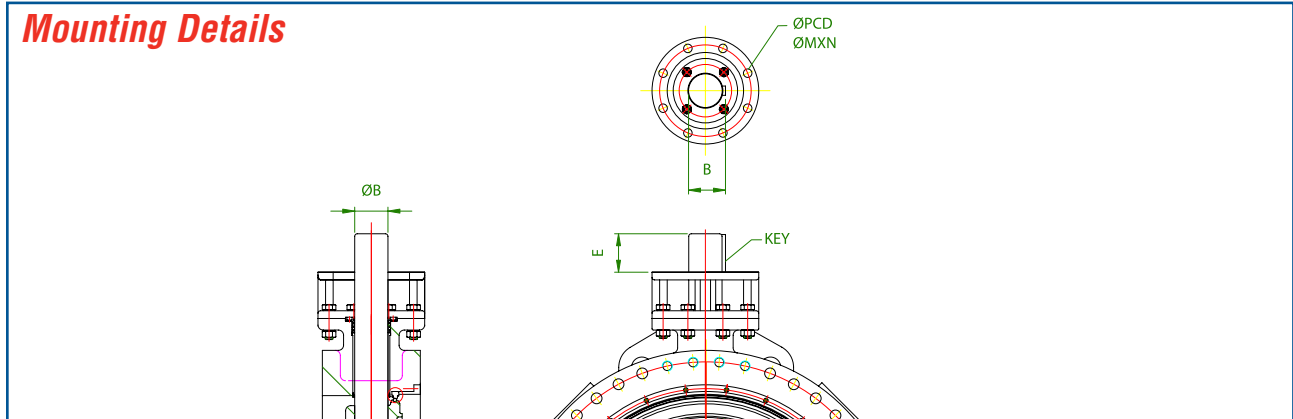

## Mounting Dimensions

SIZE		MOUNTING FLANGE (ISO 5211)				SHAFT END			KEY
mm	inch	TYPE	PCD	ØM	N	ØB	B	E	
350		F14	140	18	4	44.7	47.7	70	12x8
	14		5.51	0.71		1.76	1.88	2.8	
400		F14	140	18	4	54.7	58.7	70	16x10
	16		5.51	0.71		2.15	2.31	2.8	
450		F16	165	22	4	59.7	64.2	85	18x12
	18		6.50	0.87		2.35	2.53	3.3	
500		F16	165	22	4	59.7	64.2	85	18x12
	20		6.50	0.87		2.35	2.53	3.3	
600		F16	165	22	4	69.7	74.2	85	18x12
	24		6.50	0.87		2.74	2.92	3.3	
700		F25	254	18	8	84.5	92.5	110	24x16
	28		10.0	0.71		3.33	3.64	4.3	
750		F25	254	18	8	89.5	97.5	110	24x16
	30		10.0	0.71		3.52	3.84	4.3	
800		F25	254	18	8	84.5	92.5	110	24x16
	32		10.0	0.71		3.33	3.64	4.3	
900		F30	298	22	8	99.3	105.3	150	28x16
	36		11.7	0.87		3.91	4.15	5.9	
1000		F30	298	22	8	104.3	110.3	150	28x16
	40		11.7	0.87		4.11	4.34	5.9	
1050		F30	298	22	8	114.3	121.3	150	32x18
	42		11.7	0.87		4.50	4.78	5.9	
1100		F30	298	22	8	114.3	121.3	180	32x18
	44		11.7	0.87		4.50	4.78	7.1	
1200		F35	356	33	8	129.3	137.3	180	36x20
	48		14.0	1.30		5.09	5.41	7.1	
1350		F35	356	33	8	149	158	180	40x22
	54		14.0	1.30		5.87	6.22	7.1	
1500		F40	406	39	8	160	169	170	40x22
	60		16.0	1.54		6.30	6.65	6.7	
1600		F40	406	39	8	179	189	170	45x25
	64		16.0	1.54		7.05	7.44	6.7	
1650		F40	406	39	8	179	189	190	45x25
	66		16.0	1.54		7.05	7.44	7.5	
1800		F48	483	39	12	190	201	200	50x28
	72		19.0	1.54		7.48	7.91	7.9	
2000		F48	483	39	12	205	216	220	50x28
	78		19.0	1.54		8.07	8.50	8.7	
2200		F48	483	39	12	203	214	220	50x28
	88		19.0	1.54		7.99	8.43	8.7	
2400		F48	483	39	12	203	214	230	50x28
	96		19.0	1.54		7.99	8.43	9.1	
2600		F60	603	39	20	260	272	300	63x32
	104		23.7	1.54		10.24	10.71	11.8	

## Weights

SIZE		VALVE WITH BARE SHAFT		VALVE WITH GEAR OPERATOR	
mm	inch	kg	lb	kg	lb
350	14	135	298	160	353
400	16	170	375	195	430
450	18	200	441	258	569
500	20	240	529	275	606
600	24	400	882	459	1012
700	28	610	1345	719	1585
750	30	700	1543	843	1858
800	32	891	1964	1000	2205
900	36	1050	2315	1125	2480
1000	40	1250	2756	1350	2976
1050	42	1450	3197	1550	3417
1100	44	1785	3935	1965	4332
1200	48	2121	4676	2500	5512
1350	54	3121	6881	3500	7716
1500	60	3220	7099	4220	9303
1600	64	3026	6671	4026	8876
1650	66	3812	8404	4812	10609
1800	72	6518	14370	7300	16094
2000	78	7110	15675	8109	17877
2200	88	7709	16995	8709	19200
2400	96	7500	16535	8500	18739
2600	104	9892	21808	11382	25093





**Torque Values**

SIZE		TORQUE @ ΔP 0kg/cm <sup>2</sup> 0 psi		TORQUE @ ΔP 3kg/cm <sup>2</sup> 43 psi		TORQUE @ ΔP 4.5kg/cm <sup>2</sup> 64 psi		TORQUE @ ΔP 7.5kg/cm <sup>2</sup> 107 psi		TORQUE @ ΔP 10kg/cm <sup>2</sup> 142 psi	
mm	inches	N-m	Ft-lb	N-m	Ft-lb	N-m	Ft-lb	N-m	Ft-lb	N-m	Ft-lb
350	14	320	234	325	237	330	241	625	456	890	650
400	16	460	336	475	347	490	358	875	639	1,340	978
450	18	625	456	650	475	675	493	1,200	876	1,825	1,332
500	20	760	555	850	621	950	694	1,725	1,259	2,425	1,770
600	24	1,300	949	1,450	1,059	1,625	1,186	2,675	1,953	3,950	2,884
700	28	1,775	1,296	2,125	1,551	2,525	1,843	4,125	3,011	6,025	4,398
750	30	2,075	1,515	2,450	1,789	2,890	2,110	4,730	3,453	6,890	5,030
800	32	2,675	1,953	3,175	2,318	3,780	2,759	6,025	4,398	8,690	6,344
900	36	3,825	2,792	4,550	3,322	5,410	3,949	8,425	6,150	12,050	8,797
1000	40	4,975	3,632	6,025	4,398	7,310	5,336	11,500	8,395	16,275	11,881
1050	42	5,475	3,997	6,650	4,855	8,060	5,884	12,675	9,253	17,940	13,096
1100	44	6,650	4,855	8,075	5,895	9,800	7,154	15,100	11,023	21,950	16,024
1200	48	8,300	6,059	10,200	7,446	12,550	9,162	19,500	14,235	28,125	20,531
1350	54	11,500	8,395	14,325	10,457	17,840	13,023	26,775	19,546	39,300	28,689
1500	60	16,225	11,844	19,975	14,582	24,600	17,958	36,660	26,762	53,210	38,843
1600	64	18,450	13,469	22,725	16,589	27,990	20,433	41,710	30,448	60,540	44,194
1650	66	19,675	14,363	24,200	17,666	29,770	21,732	44,360	32,383	64,375	46,994
1800	72	23,425	17,100	28,800	21,024	35,430	25,864	52,790	38,537	76,625	55,936
2000	78	28,925	21,115	35,560	25,959	43,740	31,930	65,175	47,578	94,590	69,051
2200	88	35,000	25,550	43,030	31,412	52,925	38,635	78,850	57,561	114,450	83,549
2400	96	41,675	30,423	51,225	37,394	62,975	45,972	93,825	68,492	136,200	99,426
2600	104	48,900	35,697	60,125	43,891	73,925	53,965	110,250	81,316	159,850	116,691

## Kv and Cv Values - Valve Sizing Coefficient

Size		Disc angle (Degrees open)								
mm	inch	10	20	30	40	50	60	70	80	90
350	14	145	386	681	1115	1672	2444	3482	4378	4546
		124	330	582	953	1429	2089	2976	3742	3885
400	16	197	540	952	1561	2333	3345	4863	6090	6347
		168	462	814	1334	1994	2859	4156	5205	5425
450	18	261	703	1243	1942	3019	4546	6347	7960	8320
		223	601	1062	1660	2580	3885	5425	6803	7111
500	20	347	943	1668	2744	4117	6004	8492	10627	11065
		297	806	1426	2345	3519	5132	7258	9083	9457
600	24	523	1415	2509	4091	6261	9178	12780	15869	16555
		447	1209	2144	3497	5351	7844	10923	13563	14150
700	28	721	1947	3456	5575	8577	12609	17627	21959	22902
		616	1664	2954	4765	7331	10777	15066	18768	19574
750	30	832	2230	3988	6690	10036	14582	20329	25390	26419
		711	1906	3409	5718	8578	12463	17375	21701	22580
800	32	1020	2753	4897	8063	12008	17927	24961	31051	32595
		872	2353	4185	6891	10263	15322	21334	26539	27859
900	36	1363	3679	6544	10722	16126	24017	33367	41688	43747
		1165	3144	5593	9164	13783	20527	28519	35631	37391
1000	40	1737	4683	8320	13724	20586	30622	42460	53010	55755
		1485	4003	7111	11730	17595	26173	36291	45308	47654
1050	42	1955	5292	9401	15525	23245	34568	47950	59873	62274
		1671	4523	8035	13269	19868	29545	40983	51174	53226
1100	44	2144	5807	10293	16984	25561	37999	52582	65706	68365
		1832	4963	8797	14516	21847	32478	44942	56159	58432
1200	48	2581	6973	12352	20329	30708	45462	63132	78915	82089
		2206	5960	10557	17375	26246	38856	53959	67449	70162
1350	54	3396	9092	15954	26333	39801	59015	81918	102076	106365
		2903	7771	13636	22507	34018	50440	70015	87244	90910
1500	60	4297	11494	20415	33281	50351	74627	103791	129525	134671
		3673	9824	17449	28445	43035	63784	88710	110705	115103
1600	64	4975	13381	23760	38771	58758	86636	120947	151055	156974
		4252	11437	20308	33138	50221	74048	103374	129107	134166
1650	66	5404	14582	25905	42288	64076	94441	132098	169840	181849
		4619	12463	22141	36144	54766	80719	112904	145162	155426
1800	72	6604	17756	31566	51552	78058	114942	161263	207583	222165
		5644	15176	26979	44062	66716	98241	137832	177421	189885
2000	78	8406	22473	39972	65191	98644	145822	204152	262481	281352
		7185	19208	34164	55719	84311	124634	174489	224343	240472
2200	88	10379	27877	49751	80632	122662	180992	253045	325957	349117
		8871	23826	42522	68916	104839	154694	216278	278596	298391
2400	96	12866	33968	60730	98644	150111	221307	308801	398010	425460
		10997	29032	51906	84311	128300	189151	263932	340179	363641
2600	0	15440	40916	72997	118373	180134	265912	371419	478642	512096
		13197	34971	62391	101174	153961	227275	317452	409096	437689

## Flowserve RF Automated Valve Systems

Flowserve offers a comprehensive range of Automax, Norbro and Worcester electrical and pneumatic actuators and instrumentation allowing us to supply complete automated on-off or modulating packages to meet exacting customer requirements.



### Actuators

For pneumatic and hydraulic applications, we are pleased to offer the Automax RG-Series Scotch Yoke actuators that provide torque outputs up to 2.2 million in-lbs which can handle the full torque requirements of the RF range of valves. The RG actuators achieve superior performance by using a superior yoke support system that significantly reduces transverse loads. The RG actuators feature modular construction which allows convenient interchangeability and maximizes flexibility in the field including:

- Double acting or spring return (FCW or FCCW) modules
- Pneumatic or hydraulic pressure modules
- Torque module with symmetrical or canted yokes
- Override options - direct drive jackscrew, bevel gear jackscrew, hydraulic override or declutchable sandwich gear override.

### Instrumentation

From actuators to positioners, limit switches to solenoid valves, Flowserve is recognized worldwide as a leader in the development and manufacture of valve automation systems and equipment. Backed by Flowserve's global resources of R&D, technical support, world class manufacturing and distribution network, we will continue to lead the industry in automation products and systems including:

- Digital network communication
- Superior diagnostics
- Intelligent valve controllers
- Comprehensive user-friendly sizing and selection software
- Dedicated technical and engineering design support

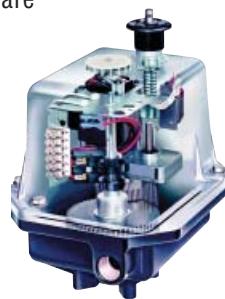



## How to specify RF Butterfly Valves



**Example: 18-RFF-1-D10A-1 shall designate a 18" (450mm) RF double offset butterfly valve, flange style, Class 150 flange drilling with ductile iron body, 316 SS disc, NBR seat, 410 SS shaft, enclosed gear operator**

VALVE SIZE	
14 in (350 mm)	14
16 in (400 mm)	16
18 in (450 mm)	18
20 in (500mm)	20
24 in (600 mm)	24
28 in (700 mm)	28
30 in (750 mm)	30
32 in (800 mm)	32
36 in (900mm)	36
40 in (1000 mm)	40
42 in (1050 mm)	42
44 in (1100 mm)	44
48 in (1200 mm)	48
54 in (1350 mm)	54
60 in (1500 mm)	60
64 in (1600 mm)	64
66 in (1650 mm)	66
72 in (1800 mm)	72
78 in (2000 mm)	78
88 in (2200 mm)	88
96 in (2400 mm)	96
104 in (2600 mm)	104

TYPE	
RF double offset butterfly valve	RF

END CONNECTION	
Flange	F

FLANGE DRILLING	
ASME Class 150	1
DIN PN10	2
DIN PN16	5
JIS 10K	J
AWWA C207	A

BODY MATERIAL	
Cast iron	W
Ductile cast iron	D
Super Duplex SS CE3MN	M

DISC MATERIAL	
Ductile iron	D
304 SS	9
316 SS	1
Super Duplex SS CE3MN	M

SHAFT MATERIAL	
410 SS	0
Super Duplex SS CE3MN	M

SEAT MATERIAL	
NBR (Nitrile/Buna N)	A
EPDM	E
Viton	V
Neoprene (CR)	N

OPERATOR	
Gear operator	1
Bare Stem	9

FCENBR0005-00 08/09 Printed in USA.

Flowserve Corporation has established industry leadership in the design and manufacture of its products. When properly selected, this Flowserve product is designed to perform its intended function safely during its useful life. However, the purchaser or user of Flowserve products should be aware that Flowserve products might be used in numerous applications under a wide variety of industrial service conditions. Although Flowserve can (and often does) provide general guidelines, it cannot provide specific data and warnings for all possible applications. The purchaser/user must therefore assume the ultimate responsibility for the proper sizing and selection, installation, operation, and maintenance of Flowserve products. The purchaser/user should read and understand the Installation Operation Maintenance (IOM) instructions included with the product, and train its employees and contractors in the safe use of Flowserve products in connection with the specific application. While the information and specifications contained in this literature are believed to be accurate, they are supplied for informative purposes only and should not be considered certified or as a guarantee of satisfactory results by reliance thereon. Nothing contained herein is to be construed as a warranty or guarantee, express or implied, regarding any matter with respect to this product. Because Flowserve is continually improving and upgrading its product design, the specifications, dimensions and information contained herein are subject to change without notice. Should any question arise concerning these provisions, the purchaser/user should contact Flowserve Corporation at any one of its worldwide operations or offices.

© 2009 Flowserve Corporation, Irving, Texas, USA. Flowserve is a registered trademark of Flowserve Corporation.

### Flowserve Corporation

Flow Control, 1978 Foreman Drive, Cookeville, Tennessee 38501, USA  
Phone: 931 432 402, Fax: 931 432 3105

### Flowserve Ahaus GmbH

Von Braun Straße 19a, D-48683 Ahaus, Germany  
Phone: +49 2561 686-0, Fax: +49 2561 686-39

### Flowserve Pte. Ltd.

12 Tuas Avenue 20, Republic of Singapore 638824  
Phone: +65 862 3332, Fax: +65 862 2800

### Flowserve Australia Pty. Ltd.

14 Dalmore Drive, Scoresby, Victoria, 3179, Australia  
Phone: +613-97593300