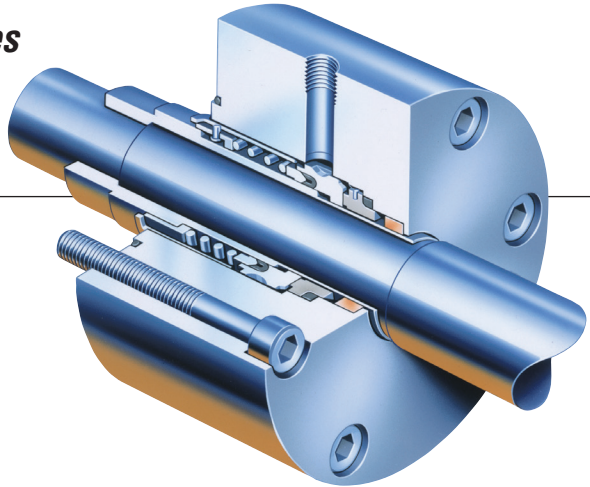

BW Seals[®] D Series

Balanced Pusher Seal
D, DP, DQ, DX, DZ

**1 Equipment Check**

- 1.1 Follow plant safety regulations prior to equipment disassembly:
 - 1.1.1 Wear designated personal safety equipment
 - 1.1.2 Isolate equipment and relieve any pressure in the system
 - 1.1.3 Lock out equipment driver and valves
 - 1.1.4 Consult plant Safety Data Sheet (SDS) files for hazardous material regulations
- 1.2 Disassemble equipment in accordance with the equipment manufacturer's instructions to allow access to seal installation area.
- 1.3 Remove existing sealing arrangement (mechanical seal or otherwise).
Clean seal chamber and shaft thoroughly.
- 1.4 Inspect surfaces under gaskets to ensure they are free from pits or scratches. Break all sharp corners on shaft steps, threads, reliefs, shoulders, key ways, etc. over which gasket(s) must pass and/or seal against.
- 1.5 Check shaft or sleeve OD, seal chamber bore, seal chamber depth, gland pilot, stud diameter, stud bolt pattern and distance to first obstruction to ensure they are dimensionally the same as shown in the seal assembly drawing.
- 1.6 Check seal assembly drawings for any modifications (reworks) to be made to the equipment for mechanical seal installation and act accordingly.
- 1.7 The equipment must be earthed to prevent sparks due to static electricity discharge.

Shaft runout should be checked against the equipment manufacturer's specifications. Generally, should not exceed 0.05 mm (0.002 inch) TIR (Total Indicator Reading) at any point along the shaft for ball or roller type bearings. For sleeve type bearings, refer to manufacturer instructions. If the equipment is not completely dismantled, verify runout near seal location.

The above values apply to shaft speeds in the range from 1000 to 3600 RPM. For values above and below, consult your Flowserve representative. See Figure 1.

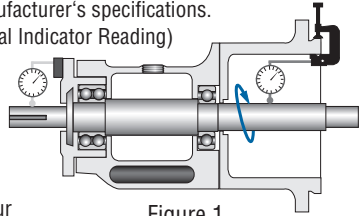

Figure 1

Shaft endplay should not exceed 0.25 mm (0.010 inch) TIR, regardless of thrust bearing type. See Figure 2.

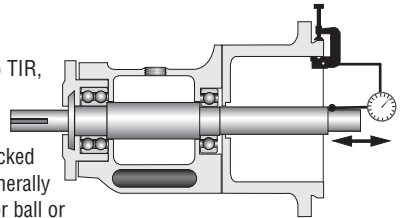

Figure 2

Radial bearing play at seal chamber face should be checked against the equipment manufacturer's specifications. Generally 0.05 - 0.10 mm (0.002 - 0.004 inch) will be applicable for ball or roller type bearings. For sleeve or journal type bearings, values will generally be in the order of 0.10 - 0.15 mm (0.004 - 0.006 inch). If equipment is found outside the general range, contact the equipment manufacturer and your Flowserve representative to verify the equipment's suitability for the seal.

Seal chamber squareness to the shaft centerline should be within 0.0005 mm/mm (0.0005 inch/inch) of seal chamber bore TIR.

Note: make sure that shaft endplay does not affect the reading. Verify the smoothness of the seal chamber face for a good gasket joint. See Figure 3.

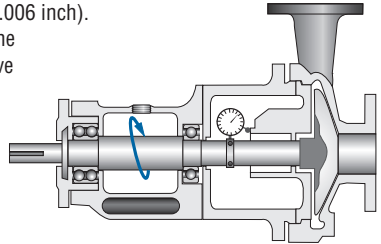

Figure 3

Concentricity of the shaft to the seal chamber bore or gland pilot register should be within 0.025 mm per 25 mm shaft diameter (0.001 inch per 1 inch shaft diameter) to a maximum of 0.125 mm (0.005 inch) TIR. See Figure 4.

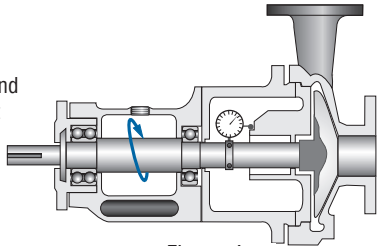
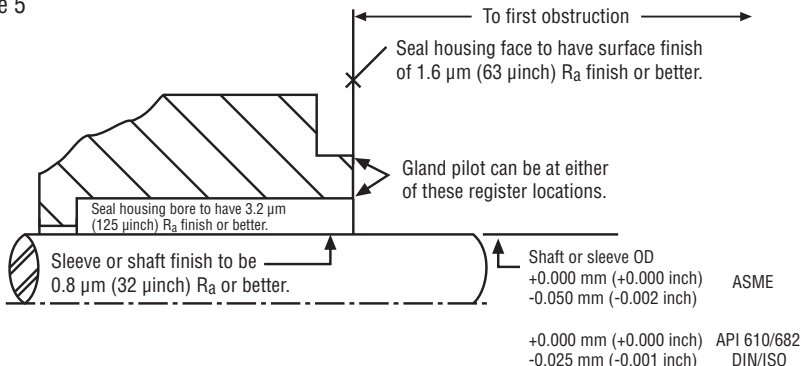

Figure 4

Surface finish requirements

Figure 5



2 Mechanical Seal Installation

- 2.1 **Review seal assembly drawing, seal assembly, and equipment** prior to installation. Read all notes on the seal assembly drawing. For hook sleeve designs, confirm the seal setting length shown on the assembly drawing matches the equipment. See Figure 1.
- 2.3 **Lightly lubricate external gaskets** with a lubricant compatible with both handled product and gasket material. Generally, silicon grease is suitable.
- 2.4 Install the seal onto the shaft and **locate it against the face of the seal chamber**. If applicable, ensure the sleeve is aligned with drive features on the shaft.
- 2.5 **Orient the ports** on the seal gland(s) as indicated by the seal assembly drawing and connected piping.
- 2.6 **Evenly torque gland bolts/nuts** for uniform gland pressure against the seal chamber. On cartridge seals, do not yet tighten drive collar screws.
- 2.7 Complete the remaining equipment assembly including bearings, if applicable.
- 2.8 On cartridge seals, **evenly tighten drive collar screws**.
- 2.9 **Disengage setting plates** from the sleeve and secure in disengaged position.
- 2.10 **Inspect equipment and driver alignment** in accordance with coupling and/or equipment manufacturer's instructions.
- 2.11 After bringing the equipment up to operating conditions, **recheck alignment** and make adjustments as necessary.

Installed Cartridge Seal Assembly and Plan 23

Figure 2

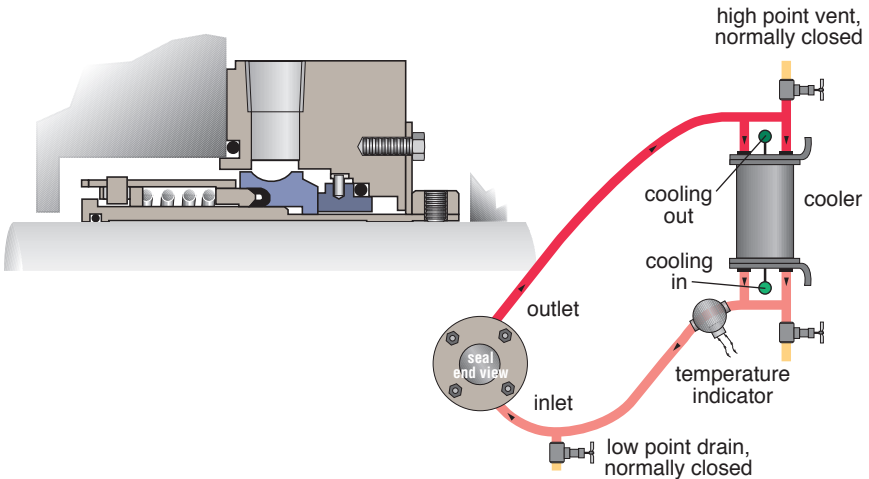

3 Piping Instructions

- 3.1 **Refer to the seal assembly drawing** for recommended seal piping plans. D seals are designed for Plan 23, follow all installation and operating instructions provided with these systems.
- 3.2 **Minimize restrictions**, total tubing length and number of bends especially in closed loop systems. Unless otherwise specified, the minimum internal diameter for tubing and connecting hardware should be 19 mm (0.750 inch).



TO REORDER REFER TO

B/M # _____

F.O. _____

- 3.3 **In Plan 23 loop systems**, pipe runs should be sloped continuously for proper venting and draining, and to promote thermosyphoning in standby condition. Include a high point vent. Unless otherwise specified, coolers must be mounted 45 - 60 cm (18 - 24 inches) above and up to 90 cm (36 inches) laterally from the center of the shaft. Reservoirs follow the same vertical guidelines and are allowed up to 120 cm (48 inches) lateral distance from the center of the shaft.
- 3.4 **Do not start the equipment dry. Vent the equipment, seal chamber, and all piping systems** then startup support systems before starting equipment.

4 Repair

This product is a precision sealing device. The design and dimension tolerances are critical to seal performance. Only parts supplied by Flowserve should be used to repair a seal. To order replacement parts, refer to the part code and B/M number. A spare backup seal should be stocked to reduce repair time.

When seals are returned to Flowserve for repair, **decontaminate the seal assembly** and include an order marked "**Repair or Replace.**" A **signed certificate of decontamination** must be attached. **A Safety Data Sheet (SDS) must be enclosed** for any product that came in contact with the seal. The seal assembly will be inspected and, if repairable, it will be rebuilt, tested, and returned.

The images of parts shown in these instructions may differ visually from the actual parts due to manufacturing processes that do not affect the part function or quality.

FIS173eng 09/2018 Printed in USA

To find your local Flowserve representative
and find out more about Flowserve Corporation,
visit www.flowserve.com

Flowserve Corporation has established industry leadership in the design and manufacture of its products. When properly selected, this Flowserve product is designed to perform its intended function safely during its useful life. However, the purchaser or user of Flowserve products should be aware that Flowserve products might be used in numerous applications under a wide variety of industrial service conditions. Although Flowserve can provide general guidelines, it cannot provide specific data and warnings for all possible applications. The purchaser/user must therefore assume the ultimate responsibility for the proper sizing and selection, installation, operation, and maintenance of Flowserve products. The purchaser/user should read and understand the Installation Instructions included with the product, and train its employees and contractors in the safe use of Flowserve products in connection with the specific application.

While the information and specifications contained in this literature are believed to be accurate, they are supplied for informative purposes only and should not be considered certified or as a guarantee of satisfactory results by reliance thereon. Nothing contained herein is to be construed as a warranty or guarantee, express or implied, regarding any matter with respect to this product. Because Flowserve is continually improving and upgrading its product design, the specifications, dimensions and information contained herein are subject to change without notice. Should any question arise concerning these provisions, the purchaser/user should contact Flowserve Corporation at any one of its worldwide operations or offices.

© 2016 Flowserve Corporation

USA and Canada

Kalamazoo, Michigan USA
Telephone: 1 269 381 2650
Telefax: 1 269 382 8726

Europe, Middle East, Africa

Etten-Leur, the Netherlands
Telephone: 31 765 028 200
Telefax: 31 765 028 487

Asia Pacific

Singapore
Telephone: 65 6544 6800
Telefax: 65 6214 0541

Latin America

Mexico City
Telephone: 52 55 5567 7170
Telefax: 52 55 5567 4224