

Waukesha 88 is also recommended for highly abrasive services where entry of black particulate matter into the product stream is not allowable.

Stellite

Stellite balls and seats will normally be specified for the most highly abrasive services.

Stellite retains its hardness to temperatures of 1500°F. It resists erosion and galling, as well as, corrosion from a wide range of acids, alkalis, and molten metals. In addition, Stellite exhibits excellent impact strength and resistance to thermal shock.

Typical applications for Stellite balls and seats in McCannaSeal's are: a limestone slurry at 1000°F in a coal gasification plant; Catalyst Regeneration Systems with the valves handling highly abrasive alumina oxide pellets and fines at 1000°F; and Iron Ore reduction plants where application temperatures can reach 1500°F.

Stellite has an excellent resistance to wire drawing and erosion and can be used in saturated steam applications considerably above the limits of carbon graphite seats. The suggested limit for Stellite seats in steam applications is 700 psig at 502°F.

In valves 3" and under, the ball and seats are constructed of solid Stellite components. In sizes 4" through 14", hard Stellite facing over SS316 substrates is used.

Special Preparation

For maximum effectiveness and sealing capabilities, the ball and seats are lapped together as a matched set ensuring full contact of seating surfaces. Back faces of the metal seats and seat surface faces of the valve body are lapped flat and smooth resulting in maximum sealing effectiveness while reducing valve torque to a minimum.

Because metal seats are utilized in severe services with cyclic temperatures, highly abrasive materials, and other similar situations, these conditions can cause the ball and seat assembly to drop further than desired into the wedge. This "dropping" occurs especially

in high temperature services where the valve body expands and then contracts during cool down. Therefore, all metal-seated ball valves are equipped with a ball stop.

The ball stop prevents the ball and seats from dropping too far into the wedge. Sealing ability is not impaired as the line pressure creates the seal by driving the ball into the downstream seat.

The ball stop sub assembly is inserted through a hole at the bottom of the body cavity and seal welded. Adjustment is not made until the stop just touches the ball when the valve is at room temperature. The ball stop can be readjusted to compensate for wear.

Extended Bonnets

Extended bonnets are recommended for temperatures above 500°F and are required for applications in the 650°F to 1000°F range. Graphite stem seals and bonnet gaskets are standard on all metal-seated ball valves.

How to Specify Order

Metal seated McCannaSeal ball valves are available in the full range of sizes (½" through 14" regular port and 1" through 12" full port) and may be specified using the standard figure number system. Waukesha 88 is the standard metal seat. Optional Stellite seats should be specified in writing on the order. Ball stops, extended bonnets, optional stem seal and bonnet gasket materials should also be specified if required.

Details of the application-pressures, temperatures, and media should be spelled out in order for Flowserve to supply the correct valve configuration (specifically the correct stem seals, bonnet gaskets, etc.) so that accurate pricing may be quoted.

Examples of Figure Number Code System

3" S301-S6-M-S0 with ball stop, extended bonnet, carbon graphite stem seals and bonnet gaskets (this indicates Waukesha 88 seats).

3" S301-S6-M-S6 with Stellite ball and seats, ball stop, extended bonnet, carbon graphite stem seals and bonnet gasket.

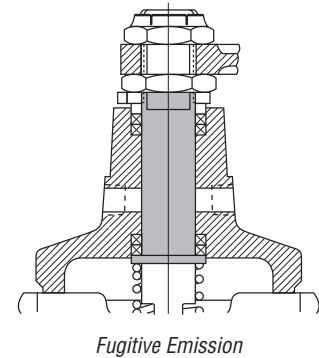
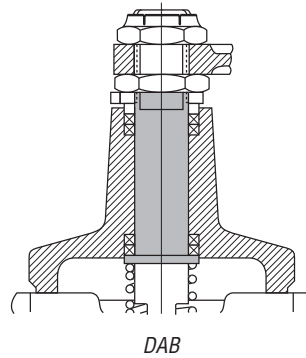
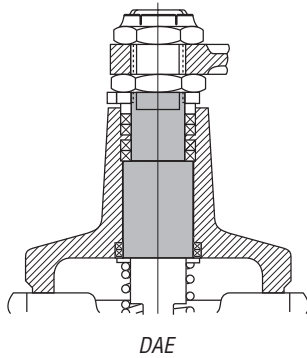
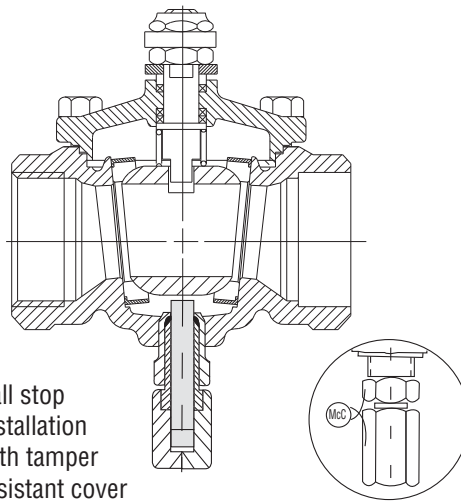



McCannaSeal® is a registered trademark of Flowserve Corporation.
Marpac® is a registered trademark of Flowserve Corporation.

For more information about Flowserve Corporation, visit www.flowserve.com or call USA 1-800-225-6989.

**FLOWSERVE CORPORATION
FLOW CONTROL DIVISION**

1978 Foreman Drive
Cookeville, Tennessee 38501 USA
Phone: 931 432 4021
Facsimile: 931 432 3105
www.flowserve.com