

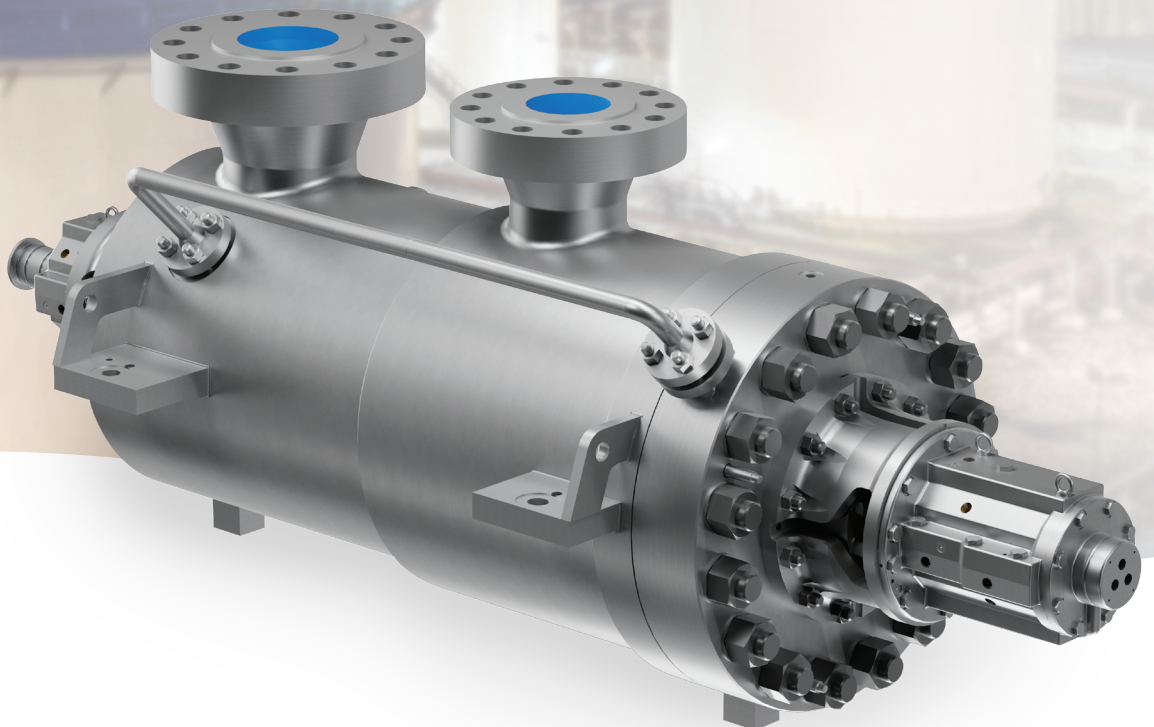

# **Oil and Gas Barrel Pumps API 610 (BB5) Multistage, Double Case Pumps**

WXB, WCC, HDO/HSO, WIK



*Experience In Motion*



## Superior barrel pump reliability for demanding oil and gas services

Multistage, double case pumps for oil and gas applications from Flowserve have been designed to meet or exceed API 610 (BB5) criteria and provide industry-leading reliability and low total cost of ownership (TCO).

Our multistage, double case, barrel pumps can be custom engineered to meet unique process requirements when installed with a spare or as an unspared unit. Superior durability is achieved through a precise combination of no-compromise rotor design, advance materials, and auxiliary seal and lubrication systems.

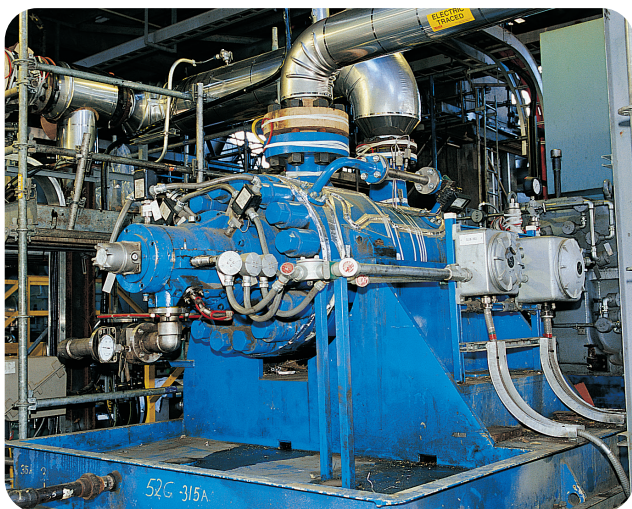

In addition, oil and gas customers benefit from our global manufacturing capabilities and decades of proven experience with BB5 pumps.

### Support for the entire pump lifecycle

Through our extensive industry experience and hydraulic engineering expertise, Flowserve is able to assist our oil and gas customers to precisely fit and economically tailor an appropriate pump and driver package for their specific applications' needs.

And with manufacturing and services operations in North and South America, Europe and Asia Pacific, we are well-positioned to meet the needs of barrel pump users worldwide.

Our global network of Quick Response Centers (QRCs) provides the engineering expertise and technical support to increase uptime for barrel pump users worldwide throughout the equipment lifecycle.

Our specialists are available to assist customers remotely and on-site. They're stocked with spare parts and tools needed for maintenance and repairs to enable customers to minimize unplanned downtime.



## A foundation of innovation and leadership

Since 1926, when we developed the first double case pump for hot oil, Flowserve has been in the vanguard of pump development for the oil and gas industry. We reinforced this leadership position in 1934 with the introduction of high-pressure water injection pumps and cemented it in 1982 when we built one of the world's largest water injection pumps (17,900 kW [24,000 hp]).

Today, we continue to be involved in establishing the API 610 standard governing the construction of these and other pumps for the oil and gas industry.

## Pump designs to meet application needs

Flowserve offers both diffuser and volute type, double case pump models for the oil and gas industries. These pumps are CE-compliant and manufactured to stringent criteria, often exceeding those established in the current edition of API 610 (BB5).

- **API performance testing** is conducted on each pump prior to shipment.
- Materials of construction are selected to meet service requirements.
  - Common options include: carbon steels, chromium steels, austenitic stainless steels, duplex stainless steels and super duplex stainless steels

- For more corrosive applications, wetted components may be carbon steel overlaid with Inconel®.
- Close clearances and critical seating fits may be fortified with a stainless steel overlay to reduce wear and erosion.
- **Wear parts and surfaces** will be optimized for each application.
  - Standard materials can be upgraded with customized surface treatments like laser hardening or Stellite®
  - Other non-metallic materials like Graphalloy® and PEEK® may be used.

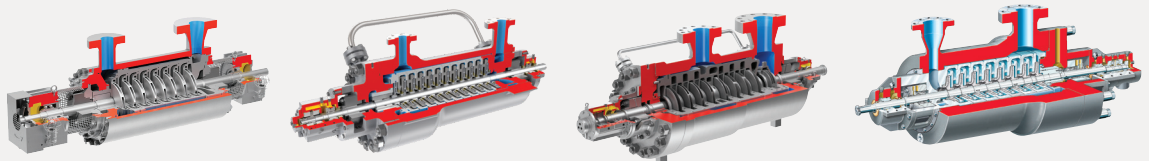

Parameter	WXB	WCC	HSO/HDO	WIK/WIKO
<b>Configuration</b>	API 610 (BB5); diffuser-style	API 610 (BB5); diffuser-style	API 610 (BB5); volute-style	API 610 (BB5); diffuser-style
<b>Flows to</b>	300 m <sup>3</sup> /h (1,320 US gpm)	1,000 m <sup>3</sup> /h (4,500 US gpm)	4,000 m <sup>3</sup> /h (17,610 gpm)	1,600 m <sup>3</sup> /h (7,000 gpm)
<b>Heads to</b>	1,200 m (3,940 ft)	4,000 m (13,100 ft)	5,500 m (18,000 ft)	7,000 m (23,000 ft)
<b>Pressures to</b>	200 bar (2,900 psi)	300 bar (4,350 psi)	450 bar (6,525 psi)	650 bar (9,425 psi)
<b>Temperatures to</b>	300°C (572°F)	425°C (800°F)	450°C (840°F)	450°C (840°F)

© Graphalloy is a registered trademark of the Graphite Metallizing Corporation.

© Inconel is a registered trademark of the International Nickel Co., Inc.

© PEEK is a registered trademark of Victrex plc Corp.

© Stellite is a registered trademark of Deloro Stellite.

## WXB multistage, diffuser barrel pump

The WXB is an API-style barrel pump that offers features common to API latest edition pumps, such as a cartridge design and renewable wear rings. It is designed for users who need the hydraulic range of a ring section pump, but demand the design and maintenance attributes of a barrel pump.

Boasting a compact, space-saving design, the WXB pump is field-proven in oil refineries and chemical, power and hydrocarbon plants throughout the world. It is an ideal choice for lower-capacity and lower-pressure services. Multiple hydraulic selections allow pumps to be sized to operate in the best efficiency range.

### Typical operating parameters

- Flows to 300 m<sup>3</sup>/h (1,320 US gpm)
- Heads to 1,200 m (3,940 ft)
- Pressures to 150 bar (2,175 psi) as standard; to 200 bar (2,900 psi) on back-to-back configuration
- Temperatures to 300°C (572°F)

### Applications

- Produced water re-injection
- Crude oil
- Solvents
- Naphtha
- Wash oil
- Hydrocarbon charge
- Condensate
- Refinery boiler feed
- Booster and recycle

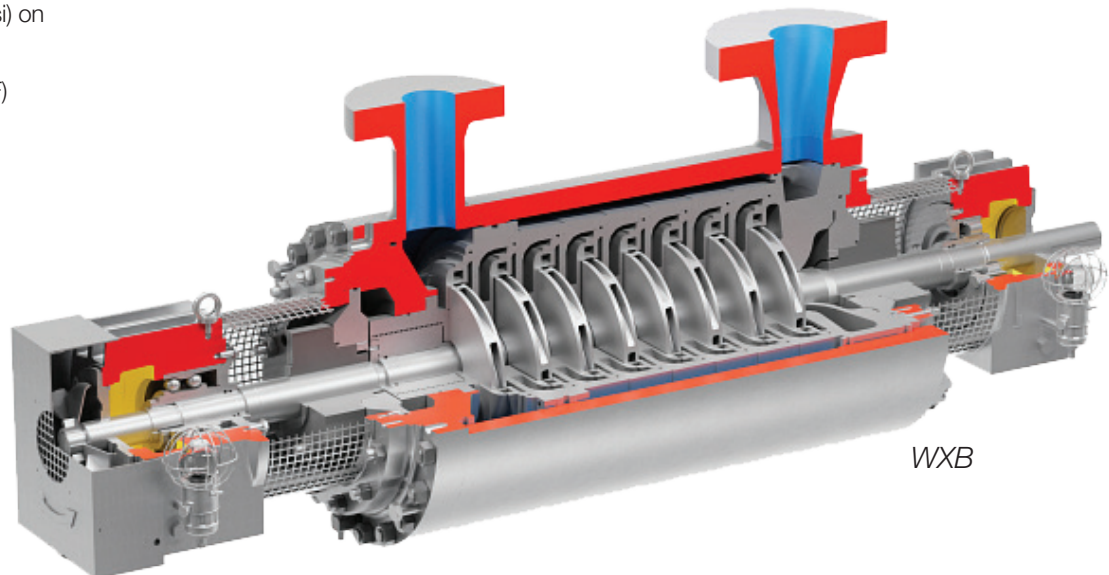

## Features and benefits

**Multi-vane diffuser construction** results in balanced radial loads over the entire flow range, including partial-load operation.

**Radially split inner case sub-assembly** includes radial and thrust bearings to facilitate maintenance in the field.

**An innovative thrust balancing device** creates nearly constant axial thrust, resulting in minimal balance line flow and improving efficiency at all loads.

**Generous shaft diameter** results in low shaft deflection, thereby increasing bearing, mechanical seal and wear ring life.

**ASME or DIN flanges** are available to meet application requirements. Other flange standards available upon special request.

**Nozzles** are top suction, top discharge as standard. Side suction, side discharge is optional.

**Cartridge-type mechanical seals** are standard and minimize downtime.

**Renewable wear rings** are standard on all casings and impellers to permit economical restoration of running clearances.

## Precision cast impellers

Impellers are precision cast and dynamically balanced to ensure hydraulic efficiency and performance repeatability. A large-eye, first-stage impeller optimizes NPSH characteristics. Each assembled rotor is checked for run-out to minimize vibration.

## Antifriction bearings

Radial bearings are antifriction rolling element type, and thrust bearings are back-to-back angular contact type. Bearings are sleeve mounted to facilitate removal when service for the bearings or the mechanical seals is required. The bearing lubrication system includes an oil bath, a constant level oiler and an oil sight glass.

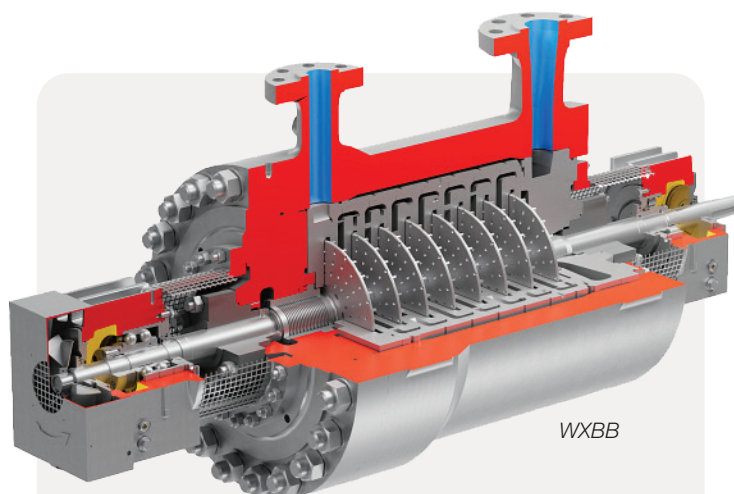

## Available low-flow configuration

An extension of the well-proven WXB product range, the WXB pump incorporates Barske-style impellers to produce stable low-flow performance. It is a reliable, direct-drive solution for low-flow, high-head applications.

- Constantly rising head curve induces stable operation at low flows.
- API-compliant vibration levels result in high reliability and extended mean time between planned maintenance.

## Optional opposed impeller configuration

A back-to-back impeller configuration is available for applications requiring higher discharge pressure. The center bushing and sleeve ensure rotor stability for pumps with higher stage counts and improve rotor dynamics.

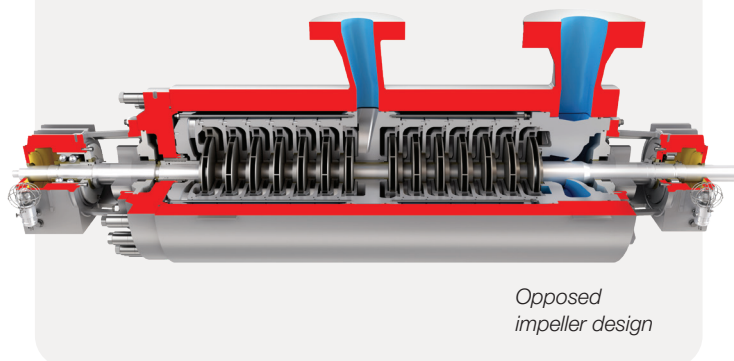

## WCC multistage, diffuser barrel pump

When process requirements demand a pump that is cost-effective, flexible *and* fully compliant with API 610 (BB5), the WCC pump is the optimum choice. With an impressive worldwide installation base, it boasts a proven design and an extensive list of options and metallurgical choices that enable it to fit almost any oil and gas application. And, its standard cartridge-type construction facilitates maintenance or a rapid changeout with a spare to minimize costs and lost production.

### Typical operating parameters

- Flows to 1,000 m<sup>3</sup>/h (4,500 US gpm)
- Heads to 4,000 m (13,100 ft)
- Pressure ratings to 300 bar (4,350 psi)
- Temperatures from -73°C to 425°C (-100°F to 800°F)
- Speeds to 6,500 rpm

### Applications

- Water injection
- Pipeline
- Amine
- Hydrocarbon charge
- Ethylene feed
- Refinery boiler feed
- Power recovery device

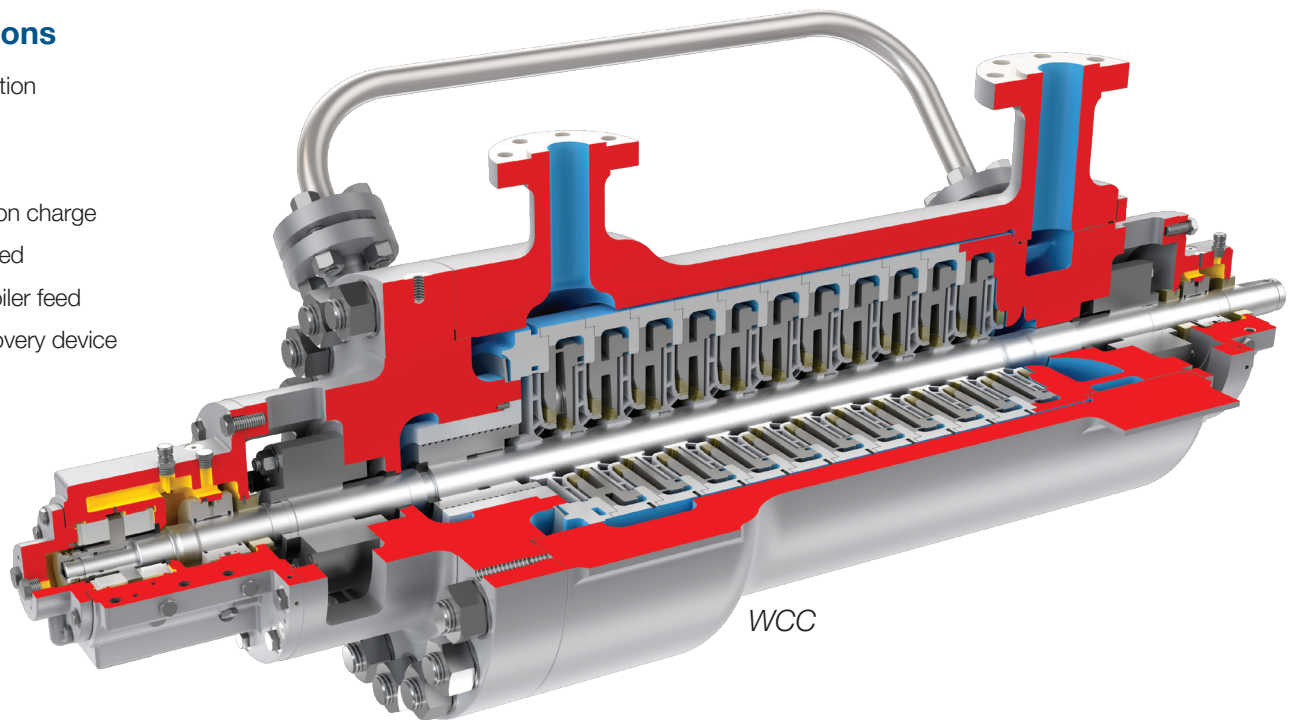

## Features and benefits

**Multi-vane diffusers** balance radial loads over the operating range while maximizing efficiencies at the duty condition. A continuous metal-to-metal seal between stage pieces minimizes risk of internal leakage.

**The standard cartridge-type inner element** includes the rotor, diffusers, discharge head, suction head and bearing assembly, allowing the entire assembly to be removed as a single unit. This design eases maintenance and reduces downtime, allowing major assembly and disassembly in the workshop, rather than the field.

**Wrought shafts** are incrementally stepped at each impeller fit for ease of assembly. Shafting is generously sized and machined to tight tolerances to minimize vibration.

**Precision cast impellers** ensure optimum hydraulic efficiency and repeatability of performance. Impeller wear surfaces—whether separate wear rings (standard) or integral (optional)—are engineered for the best possible performance.

**The single-diameter balance drum** compensates for residual axial thrust produced by the tandem impeller arrangement. The drum may be plain or serrated as appropriate for the application to reduce leakage and optimize reliability and efficiency.

**A proprietary integral cartridge compression device** prevents internal leakage over the entire operating range.

## Robust bearing system

The WCC pump is offered with a variety of bearing configurations to meet application requirements. For the most demanding applications, the standard bearing system consists of heavy-duty journal radial bearings and self-equalizing, tilting pad thrust bearings due to their reliability and versatility.

The following bearing arrangements also are available:

- Rolling element thrust bearings may be used in conjunction with either rolling element radial or self-lubricated radial sleeve bearings. Air, fan or water cooling is available as needed to suit the application requirements.
- When space is at a premium, an integral lubrication circulation system can be supplied. This system offers the benefits of circulation while maintaining a compact size and minimizing maintenance demands.

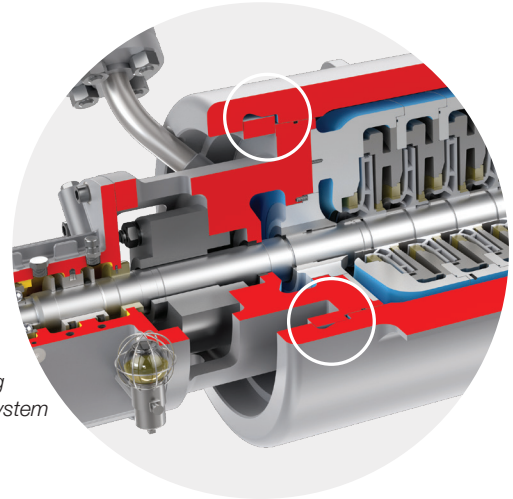

*Shear ring closure system*

## Optional shear ring closure system

As an option, a shear ring closure system can replace the traditional bolting on the discharge cover. In this configuration, the high-strength split seal ring is locked into the barrel body by cap nuts. This design maintains cartridge integrity but still allows maintenance with conventional tooling. The shear ring design is more compact and boasts one of the quickest maintenance turnarounds in the industry.

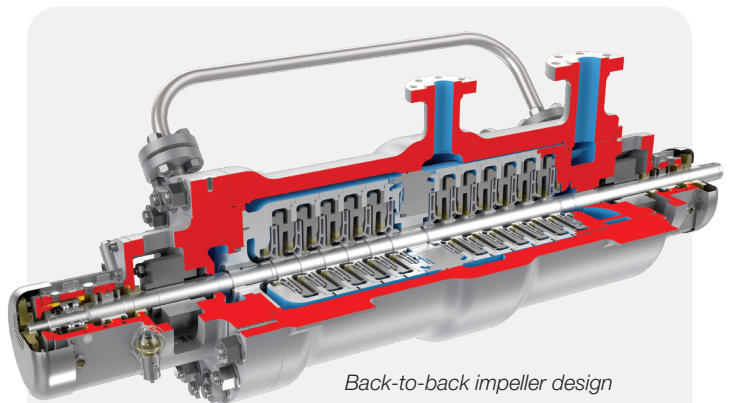

*Back-to-back impeller design*

## Available back-to-back impeller rotor

An optional back-to-back impeller configuration ensures hydraulic balance of axial thrust. This allows for rolling element bearing selections, even for conditions reaching beyond the API 610 limits. The center bushing and sleeve provide improved rotor dynamics by adding rotor stability and low vibration levels for higher stage counts, even in low-density applications.

The cross-under/crossover piece is designed specifically for each hydraulic to guarantee an optimized performance and reliable operation.

## HDO and HSO multistage, volute barrel pumps

HDO and HDO pumps are unique in that they are offered in general or special purpose configurations. While the two configurations address different applications requirements, both are fully compliant with API 610 (BB5).

General purpose HSO and HDO pumps are designed for those users who have an installed spare but prefer a volute design. With a hydraulic envelope that fits many general service applications, the versatile HSO and HDO pumps offer a volute solution for customers who do not need the premium design features and expenses of a special purpose pump, but still desire the advantages of a volute design.

For applications that require the highest reliability and the features of a volute design, special purpose HSO and HDO pumps are the optimum choice. The special purpose pump design retains all of the advantages of a volute double case while offering enhanced features for service in critical processes.



### Typical operating parameters

- Flows to 4,000 m<sup>3</sup>/h (17,610 US gpm)
- Heads to 5,500 m (18,000 ft)
- Pressures to 450 bar (6,525 psi)
- Temperatures to 450°C (840°F)
- Speeds to 9,000 rpm

### Applications

- Water injection
- Pipeline
- Amine
- Hydrocarbon charge
- Ethylene feed
- Refinery boiler feed
- Power recovery device

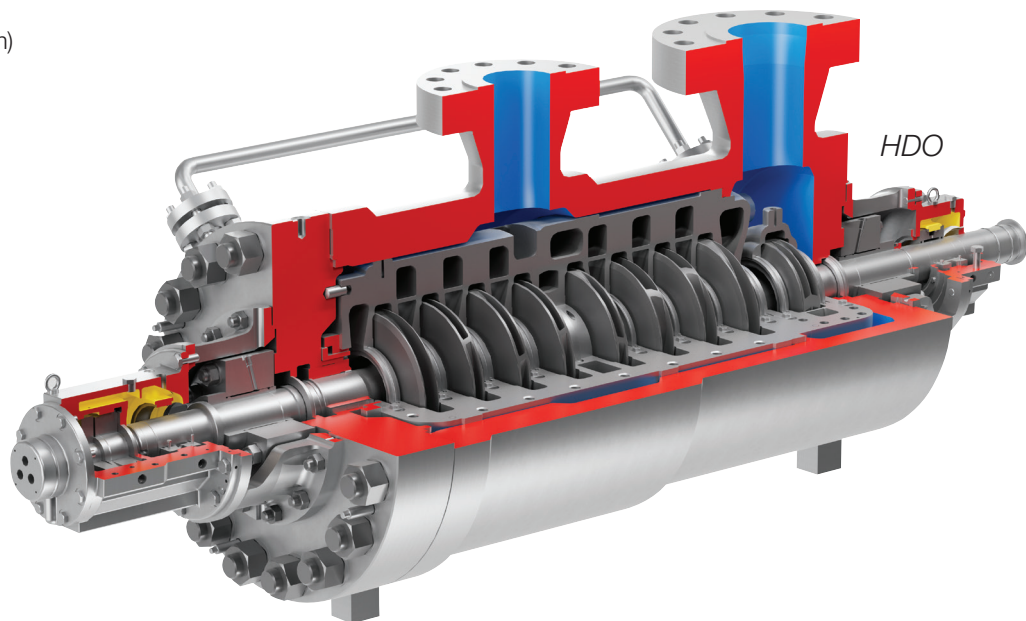



## Features and benefits

**Double volute casing** consists of two identical halves which feature dual volutes with outlets 180 degrees apart. This design assures radial balance throughout the entire operating range, reducing harmful vibration and ensuring dependable performance.

**Nozzles** have standard raised face flanges. Nozzle orientation can be adjusted to suit site requirements. Several nozzle configurations are available. Weld-end, ring-type joint, and tongue and groove flanges are optional.

**Wrought shafts** are incrementally stepped at each impeller fit for ease of assembly. The standard shaft extension is a shaft end taper.

**Sleeve journal radial bearings** and tilting pad thrust bearings are standard, utilizing either air or water cooling as needed. Duplex ball and sleeve/ball bearings are available where appropriate and permitted by API 610 (BB5).

**Dynamically balanced rotor** provides excellent rotor dynamic stability. The fully assembled rotor is balanced as a complete unit before installation.

## Axially balanced configuration

The volute-type opposed impeller design of the HDO and HSO pumps results in nearly balanced axial hydraulic thrust over the full operating range of the pump. Furthermore, this arrangement limits the pressure breakdown across the running clearances to a maximum of 50% of the pressure differential at the center bushing and the balance stage piece.

## Precision-cast impellers

Impellers are precision cast to improve hydraulic efficiency and performance repeatability. The impellers are secured to the stepped shaft with a shrink-fit. Axial movement is prevented by split rings. Standard single-suction (HSO) or optional double-suction (HDO), first-stage impellers provide the flexibility to meet a variety of NPSH requirements.

## Fully machined inner casing halves

Inner casing halves are fully precision machined and operate under hydraulic compression, thereby eliminating the need for gasketing. Only light bolting is required, facilitating dismantling for maintenance.



# WIK multistage, diffuser barrel pump

When the pump specification analysis results in the need to install only one pump and still have unmatched dependability, the WIK pump is the preferred choice. With a design based on an uncompromised engineering philosophy, the WIK pump is unmatched by any pump in its class. Fully compliant with API 610, this special purpose diffuser-style pump includes superior rotor dynamics, unequalled mechanical design, and a proven record of global experience in unspared service.

## Typical operating parameters

- Flows to 1,600 m<sup>3</sup>/h (7,000 US gpm)
- Heads to 7,000 m (23,000 ft)
- Pressure to 650 bar (9,425 psi)
- Temperatures to 450°C (840°F)
- Speeds to 9,000 rpm

## Applications

- Decoking jet water
- Hydrocarbon charge
- Seawater injection
- Produced water re-injection
- Main oil line
- Pipeline
- Lean solution/amine gas processing service
- Reactor feed/ethylene charge
- High-pressure CO<sub>2</sub> injection

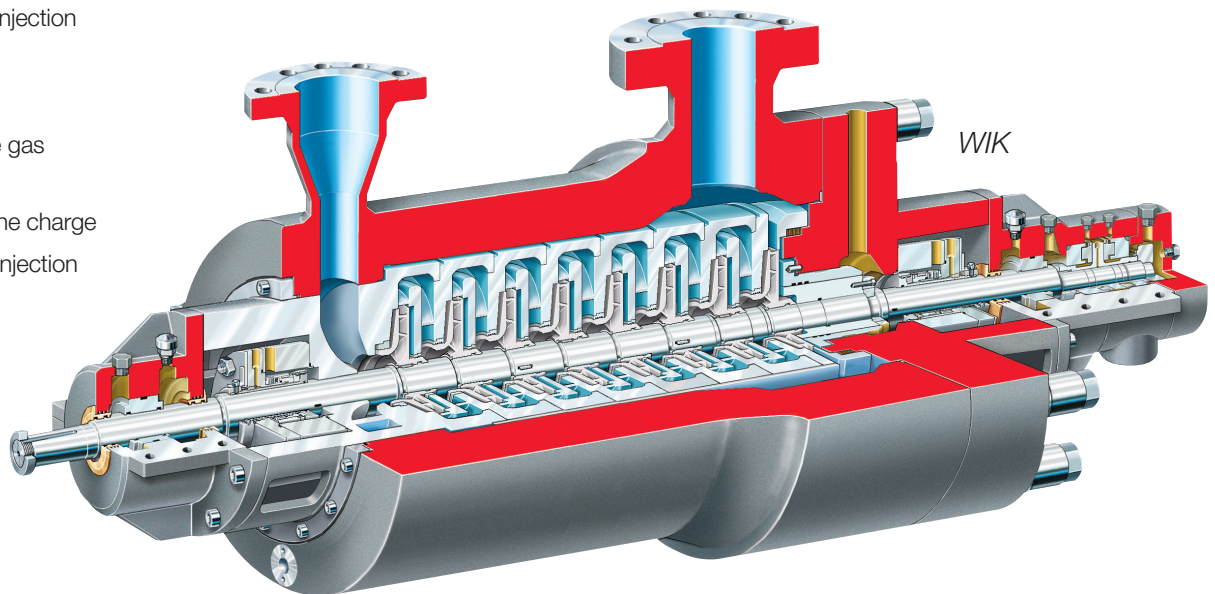

## Features and benefits

**High-stiffness rotor** with low static deflection is the result of a large-diameter shaft, short bearing spans, unique low specific speed hydraulic designs and high design speeds. This reduces the risk of accidental contact within the running clearances and improves the pump's tolerance to operational upsets.

**Multi-vane, radially split diffuser and channel ring collectors** are cast components, eliminating radial imbalance across the entire operating range. Collectors provide continuous metal-to-metal sealing between stages and also between inner and outer casings. Collectors are milled to create smooth passageways and ensure repeatability of performance.

**Large-diameter shafts** are incrementally stepped at all of the impeller, seal and thrust collar fits for ease of assembly. Shafts are thermally stabilized to eliminate potential distortion from residual stresses.

**Heavy-duty, journal-type radial bearings** are pressure-lubricated for long life.

**Heavy-duty tilting pad thrust bearings** are leading edge groove (L.E.G.) pressure-lubricated, self-equalizing type. Bearings and forced feed lubricating systems are conservatively sized for each application.

**Normal single, dual pressurized and unpressurized mechanical seals** are contained within a full API 682 seal chamber. Wet and dry gas seals are also available and utilized when appropriate.

**Forged barrel casing and discharge head** are custom designed for each application and manufactured from high-strength forgings to ensure unparalleled durability.

## Unique low specific speed impellers

Precision cast, low specific speed impellers are statically and dynamically balanced. Impellers are double keyed and positively secured against axial movement by split rings and a shrink-fit on a stepped shaft. Large-eye, single-suction or alternate double-suction, first-stage impellers are available, depending on NPSH conditions. Impeller hubs have integral hardened wear surfaces.

## Single-diameter balance drum

The single-diameter balance drum compensates for the residual axial thrust produced by the tandem impeller arrangement. The sleeve is grooved against the flow to improve rotor stability, lower balancing leak-off flow, and reduce the risk of galling in the running clearance. It is mounted with a shrink-fit key driven and located with a split ring.

## Back pullout, cartridge construction

The standard construction cartridge-style inner case sub-assembly includes the rotor, diffusers, discharge head, suction head, seals and bearing assemblies. This design eases maintenance by allowing quick replacement of the entire sub-assembly. Major assembly, disassembly, and mechanical seal and rotor setting can then be performed in the shop, rather than in the field. A conventional construction version is also available.

## WIKO pump: Opposed impeller design for extreme pressures

The WIKO pump was developed to meet ever-increasing customer requirements for extreme discharge pressures and the need to balance residual axial thrust. By pairing an opposed impeller rotor with diffuser collectors and a single-diameter balance drum, this design can be customized to meet higher pressures.

Every WIKO pump is custom designed and built to order for specific ultra high-pressure applications.

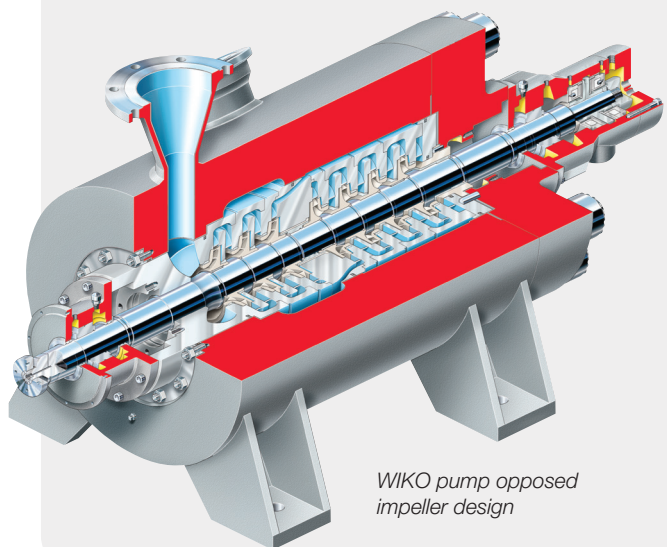

WIKO pump opposed impeller design



## Increase uptime with predictive maintenance

Flowserve barrel pumps are RedRaven Ready. RedRaven is a predictive maintenance service from Flowserve that improves plant performance by detecting anomalies in pumps, valves and seals. It enables you to predict when and why your critical assets may experience issues so you can take preventive action.

RedRaven is a complete end-to-end proactive maintenance solution. It enables you to leverage the internet of things (IoT) for a connected platform of smart products, software and services. It gives you the tools you need to monitor, analyze and predict the performance of your pumps, seals and valves, as well as the insights you need to make more informed decisions for improving your plant's reliability, efficiency, productivity and bottom line.



### A ready-to-deploy, scalable solution

Most Flowserve fluid motion and control equipment is RedRaven Ready. That means it's designed and built to accept RedRaven wired or wireless sensors using cloud architecture for condition monitoring and predictive analytics services.

RedRaven Ready pumps, seals and valves securely connect to an IoT platform that includes hazardous area-certified equipment sensors, secure communication, performance analytics and trend reporting tools — all tailored to your plant's unique needs.

Options include:

**Condition monitoring:** Enables you to capture asset performance data for analysis

**Predictive analytics:** Applies data analysis software and algorithms to help you identify and diagnose equipment problems

For more information on RedRaven, contact your Flowserve representative or visit [www.flowserve.com/redraven](http://www.flowserve.com/redraven)

Flowserve Corporation  
5215 North O'Connor Blvd.  
Suite 700  
Irving, Texas 75039-5421 USA

Flowserve Corporation has established industry leadership in the design and manufacture of its products. When properly selected, this Flowserve product is designed to perform its intended function safely during its useful life. However, the purchaser or user of Flowserve products should be aware that Flowserve products might be used in numerous applications under a wide variety of industrial service conditions. Although Flowserve can provide general guidelines, it cannot provide specific data and warnings for all possible applications. The purchaser/user must therefore assume the ultimate responsibility for the proper sizing and selection, installation, operation, and maintenance of Flowserve products. The purchaser/user should read and understand the Installation Instructions included with the product, and train its employees and contractors in the safe use of Flowserve products in connection with the specific application.

While the information and specifications contained in this literature are believed to be accurate, they are supplied for informative purposes only and should not be considered certified or as a guarantee of satisfactory results by reliance thereon. Nothing contained herein is to be construed as a warranty or guarantee, express or implied, regarding any matter with respect to this product. Because Flowserve is continually improving and upgrading its product design, the specifications, dimensions and information contained herein are subject to change without notice. Should any question arise concerning these provisions, the purchaser/user should contact Flowserve Corporation at any one of its worldwide operations or offices.

©2023 Flowserve Corporation. All rights reserved. This document contains registered and unregistered trademarks of Flowserve Corporation. Other company, product, or service names may be trademarks or service marks of their respective companies.

PUBR000067-08 (EN/A4) June 2023