

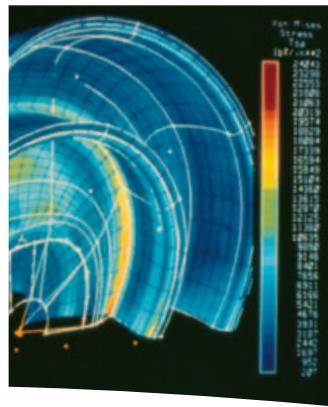

***MVX***  
***Solids-Handling, Wet-Pit Pump***



***Experience In Motion***



## ***Pump Supplier to the World***

*Flowserve is the driving force in the global industrial pump marketplace. No other pump company in the world has the depth or breadth of expertise in the successful application of pre-engineered, engineered and special purpose pumps and systems.*

### ***Life Cycle Cost Solutions***

Flowserve is providing pumping solutions which permit customers to reduce total life cycle costs and improve productivity, profitability and pumping system reliability.

### ***Market Focused Customer Support***

Product and industry specialists develop effective proposals and solutions directed toward market and customer preferences. They offer technical advice and assistance throughout each stage of the product life cycle, beginning with the inquiry.

### ***Broad Product Lines***

Flowserve offers a wide range of complementary pump types, from pre-engineered process pumps, to highly engineered and special purpose pumps and systems. Pumps are built to recognized global standards and customer specifications.

Pump designs include:

- Single-stage process
- Between bearing single-stage
- Between bearing multistage
- Vertical
- Submersible motor
- Rotary
- Reciprocating
- Nuclear
- Specialty

### ***Product Brands of Distinction***

*ACEC™ Centrifugal Pumps*

*Aldrich™ Pumps*

*Byron Jackson® Pumps*

*Calder™ Energy Recovery Devices*

*Cameron™ Pumps*

*Durco® Process Pumps*

*Flowserve® Pumps*

*IDP® Pumps*

*Lawrence Pumps®*

*Niigata Worthington™ Pumps*

*Pacific® Pumps*

*Pleuger® Pumps*

*Scienco™ Pumps*

*Sier-Bath® Rotary Pumps*

*TKL™ Pumps*

*United Centrifugal® Pumps*

*Western Land Roller™ Irrigation Pumps*

*Wilson-Snyder® Pumps*

*Worthington® Pumps*

*Worthington Simpson™ Pumps*

**MVX  
Solids-Handling,  
Wet-Pit Pump**

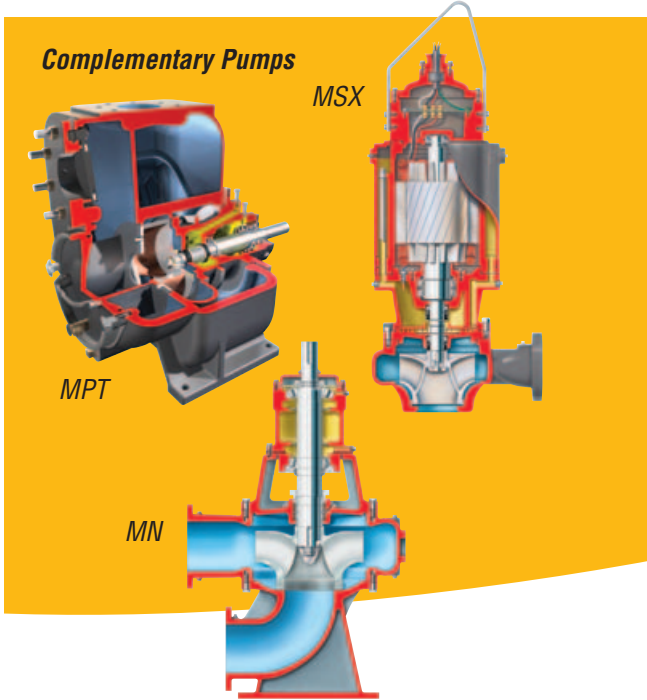

**Robust and Dependable**

The Flowserve MVX is a rugged wet-pit pump designed for use in solids-handling applications and other wet-pit services. Built and tested in conformance with the standards of the Hydraulic Institute, the MVX non-clog pump boasts numerous reliability and performance enhancing benefits:

- Large waterways to minimize clogging
- The absence of a bearing below the impeller allows unrestricted intake of large solids
- Smallest model passes spherical solids up to 76 mm (3 in) diameter; larger models pass spherical solids up to 152 mm (6 in) diameter
- Multi-volute design with perfect balance of radial reactive forces for smooth performance
- Specially designed solids-handling impeller
- Splitter vane to prevent solids from wrapping around the enclosing tube
- Enclosed lineshaft to protect bearing surfaces from abrasives

**Typical Applications**

- Raw Sewage
- Return Activated Sludge
- Waste Activated Sludge
- Effluent
- Mixed Liquor
- Filter Backwash
- Industrial Wastewater
- Irrigation
- Flood Protection
- Dewatering
- Leachate
- Trash Pumping
- Raw Water

**Complementary Pump Designs**

Flowserve also provides the following non-clog, solids-handling pump models:

- MF and MN dry-pit pumps with side or bottom suction
- MPT self-priming pump
- MSX submersible pump



**MVX**  
**Solids-Handling,**  
**Wet-Pit Pump**

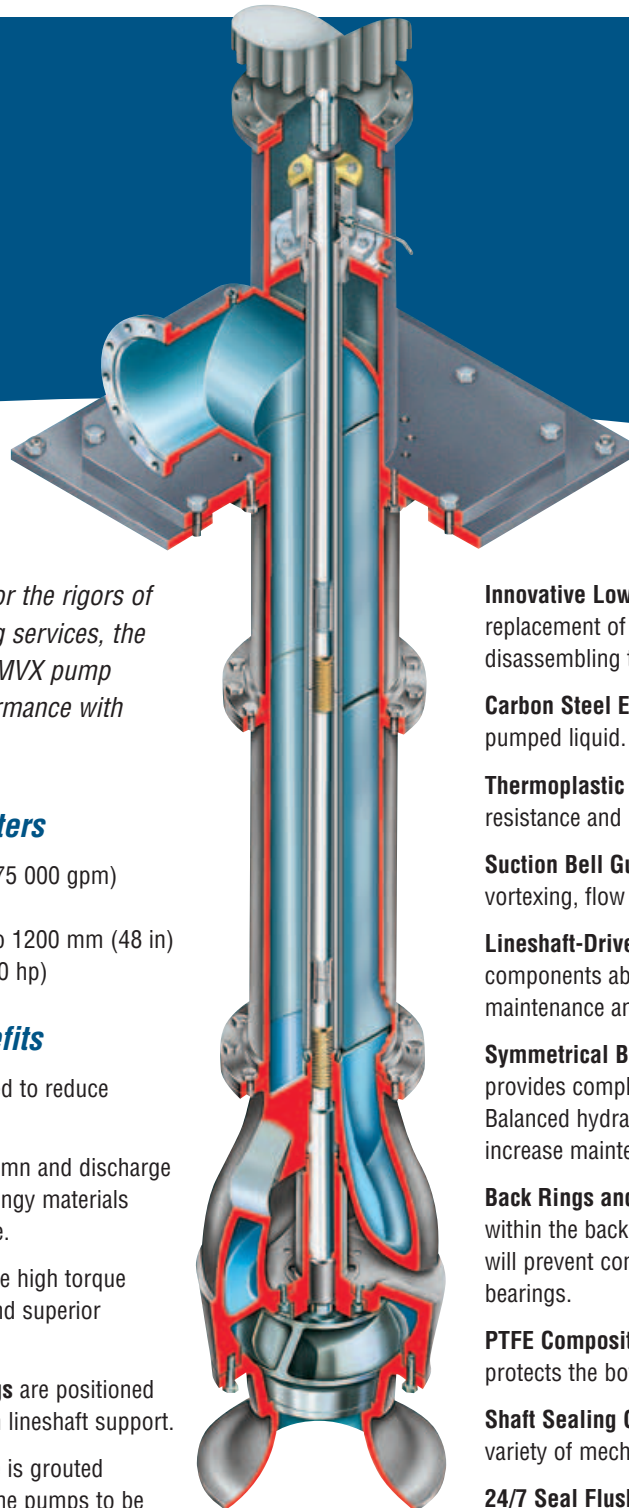

*Specifically designed for the rigors of wet-pit, solids-handling services, the heavy-duty Flowserve MVX pump provides reliable performance with minimal maintenance.*

**Operating Parameters**

- Flows to 17 000 m<sup>3</sup>/h (75 000 gpm)
- Heads to 40 m (130 ft)
- Sizes 250 mm (10 in) to 1200 mm (48 in)
- Drivers to 950 kW (1250 hp)

**Features and Benefits**

**Discharge Head** is mitered to reduce friction losses.

**Splitter Vanes** in the column and discharge head guide solids and stringy materials around the enclosing tube.

**416 SS Lineshafts** provide high torque transmission capability and superior corrosion resistance.

**Bronze Lineshaft Bearings** are positioned every 1.5 m (5 ft) for firm lineshaft support.

**Separate Steel Soleplate** is grouted and leveled. This allows the pumps to be removed for service without disturbing the grout.

**Column Pipe** is constructed in interchangeable 3 m (10 ft) sections and is connected by registered flanged joints to ensure proper alignment.

**Innovative Lower Bearing Cartridge** design allows replacement of the bottom bowl bearing without disassembling the entire pump.

**Carbon Steel Enclosing Tube** protects lineshaft from pumped liquid.

**Thermoplastic Bowl Bearing** offers superior abrasion resistance and increases load carrying capability.

**Suction Bell Guide Vanes** provide straight, non-vortexing, flow into impeller eye.

**Lineshaft-Driven Impeller** places all electrical components above flood levels, simplifying maintenance and increasing personnel safety.

**Symmetrical Bowl** with its multi-volute design provides complete balance of radial reactive forces. Balanced hydraulic forces reduce bearing load and increase maintenance intervals.

**Back Rings and Relief Ports** reduce the pressure within the back rings to submergence pressure. This will prevent contaminants from freely flowing into the bearings.

**PTFE Composite Lip Seal** resists abrasion and protects the bowl bearing.

**Shaft Sealing Options** include soft packing or a variety of mechanical seal types and mountings.

**24/7 Seal Flush System** increases pump reliability.

**High-efficiency Enclosed Non-Clog Impeller** is designed with a minimum number of vanes for maximum capability to pass solids.

**Standard Suction Bell Wear Ring** and optional impeller wear ring enable renewal of clearances and hydraulic efficiency.



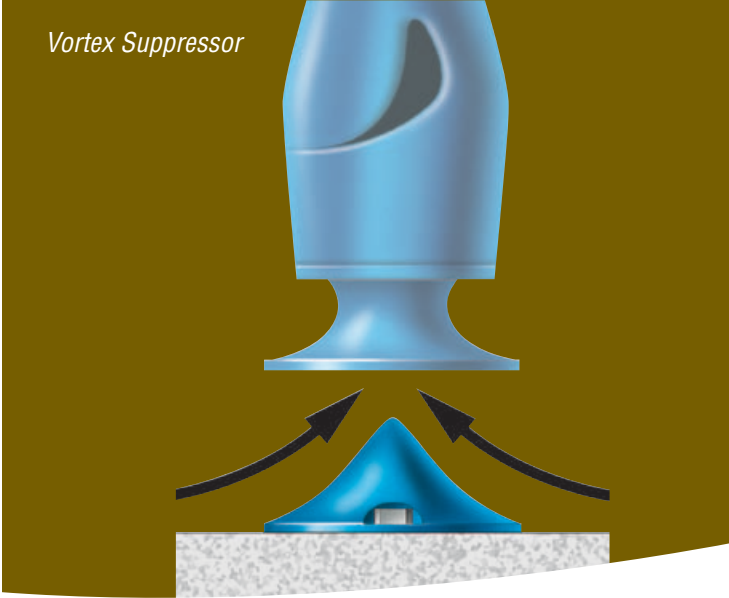

**Heavy-Duty Discharge Head Provides Motor Flexibility and Flow Guidance**

The MVX’s three-section mitered discharge head provides rigid and stable support for solid or hollow shaft P-base motors. The discharge head also incorporates a splitter vane which is blended with the column splitter vane. Together, these splitter vanes guide solids and stringy materials around the pump’s enclosing tube and into the discharge without clogging. This design serves to maintain hydraulic efficiency and increase pump reliability.

**Available Vortex Suppressor Ensures Hydraulic Efficiency**

The MVX pump is available with a vortex suppressor to ensure maximum hydraulic efficiency. Constructed of either cast iron or fabricated steel, the suppressor is installed at the bottom of the sump under the pump suction to minimize vortex formation and guide the flow uniformly into the suction bell.

**Enclosed, Mixed Flow Impeller Minimizes Clogging**

Designed with a minimum number of vanes and wide passageways to prevent clogging, the MVX impeller is well-suited for solids-handling applications. Vane tips are rounded to prevent the accumulation of stringy materials at the impeller eye. All MVX pumps pass 76 mm (3 in) spherical solids at a minimum.

Back rings and a relief port reduce the pressure at the rear of the impeller to prevent contaminants from flowing into the lower bearings.

Each impeller is dynamically balanced prior to assembly and positively secured to the shaft with a key, a contoured washer and a locking cap screw.

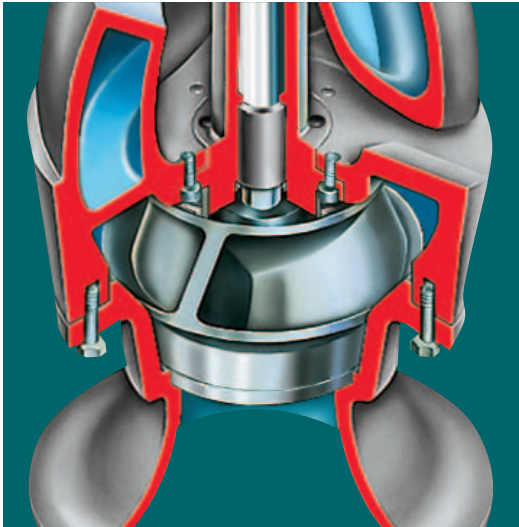

**Self-Cleaning Trench Wet Well**

The MVX pump is ideally suited for use in self-cleaning trench wet well applications.

**Options and  
Technical Data**

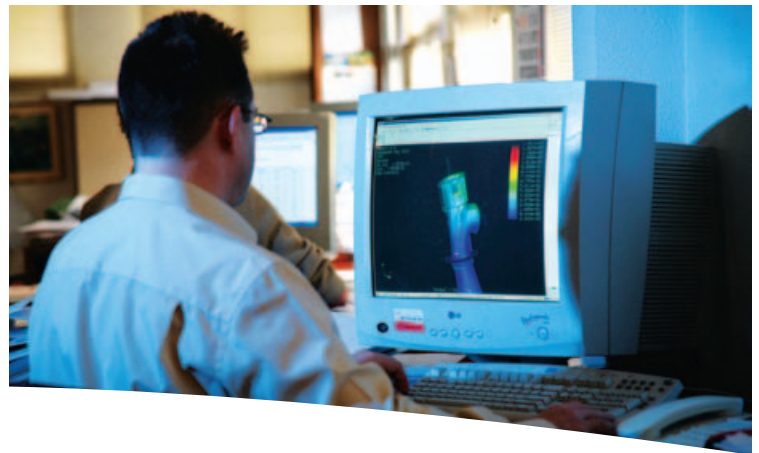

**Available Materials of Construction**

Stationary Parts	
Pump Head	Steel
Bowl	Cast Iron
Suction Bell	Cast Iron
Lineshaft Bearings	Bronze
Bowl Bearing	Thermoplastic
Lower Lip Seal	PTFE Composite
Shaft Plating	Nickle, Tungsten, Chromium Alloy
Packing Box	Cast Iron
Wear Ring	Stainless Steel
Rotating Parts	
Impeller	Cast Iron
Lineshaft	Stainless Steel
Wear Ring	Stainless Steel

**Available Discharge Configurations**

MVX pumps are available with above or below ground discharge flanges to suit site conditions.

**FEA Ensures Stability**

A finite element analysis is performed on all MVX pumps to ensure vibration damage will not negatively impact pump performance. By identifying and rectifying potential vibration sources, maintenance is reduced and pump life is prolonged.

**MVX Range Chart**

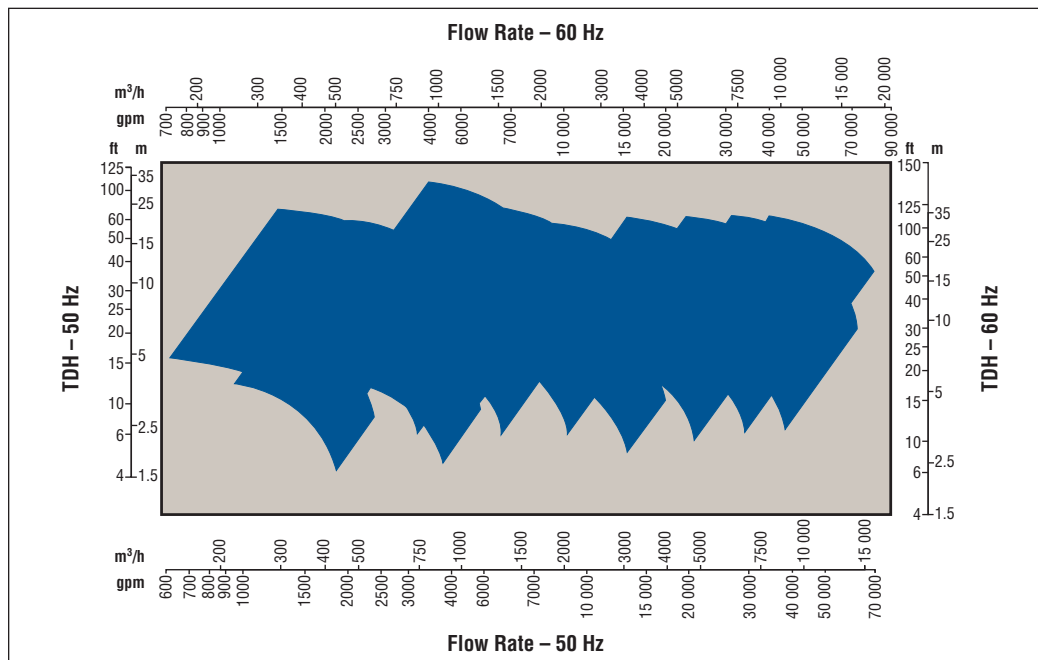

**Global Service and Technical Support**

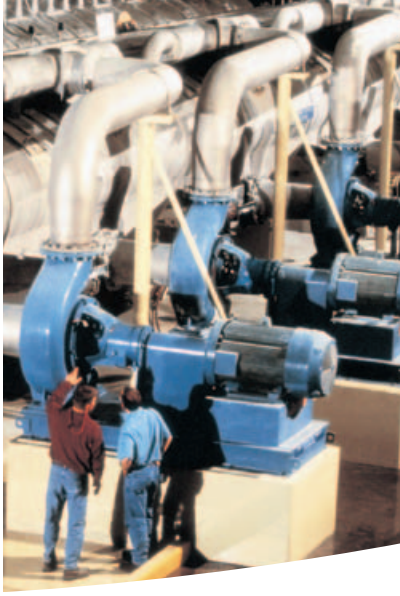

### Life Cycle Cost Solutions

Typically, 90% of the total life cycle cost (LCC) of a pumping system is accumulated after the equipment is purchased and installed. Flowserve has developed a comprehensive suite of solutions aimed at providing customers with unprecedented value and cost savings throughout the life span of the pumping system. These solutions account for every facet of life cycle cost, including:

**Capital Expenses**

- Initial purchase
- Installation

**Operating Expenses**

- Energy consumption
- Maintenance
- Production losses
- Environmental
- Inventory
- Operating
- Removal

**Innovative Life Cycle Cost Solutions**

- New Pump Selection
- Turnkey Engineering and Field Service
- Energy Management
- Pump Availability
- Proactive Maintenance
- Inventory Management

### Typical Pump Life Cycle Costs<sup>1</sup>

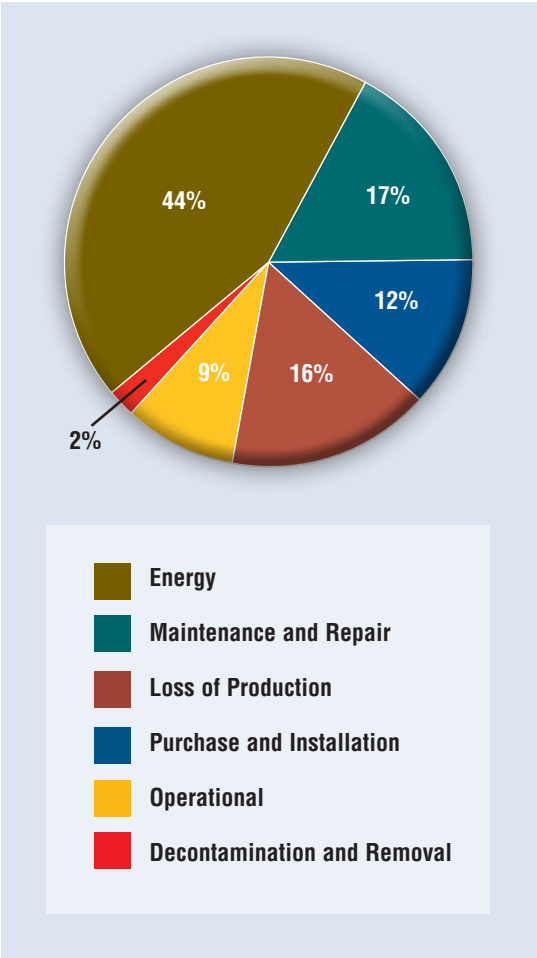

<sup>1</sup> While exact values may differ, these percentages are consistent with those published by leading pump manufacturers and end users, as well as industry associations and government agencies worldwide.





**USA and Canada**

Flowserve Corporation  
5215 North O'Connor Blvd.  
Suite 2300  
Irving, Texas 75039-5421 USA  
Telephone: +1 937 890 5839

**Europe, Middle East, Africa**

Flowserve Corporation  
Parallelweg 13  
4878 AH Etten-Leur  
The Netherlands  
Telephone: +31 76 502 8100

**Latin America**

Flowserve Corporation  
Martín Rodríguez 4460  
B1644CGN-Victoria-San Fernando  
Buenos Aires, Argentina  
Telephone: +54 11 4006 8700  
Telefax: +54 11 4714 1610

**Asia Pacific**

Flowserve Pte. Ltd.  
10 Tuas Loop  
Singapore 637345  
Telephone: +65 6771 0600  
Telefax: +65 6779 4607

Bulletin PS-40-5c† (E) Printed in USA. January 2011. © Flowserve Corporation

*To find your local Flowserve representative:*

For more information about Flowserve Corporation,  
visit [www.flowserve.com](http://www.flowserve.com) or call +1 937 890 5839.