



# API 610 Multistage Water Injection Pumps

DMX • WCC • HSO/HDO • WIK/WIKO



*Experience In Motion*



## Superior pumping solutions for water injection service

Water injection is one of the key technologies oil and gas producers rely on to increase recovery rates. Trends toward higher pressures and more corrosive and erosive fluids create significant pumping challenges. Operations require efficient pumps that can reliably perform under high pressures for extended periods.

Flowserve has proven to be the world leader in meeting the changing and demanding needs of the oil and gas industry. We offer the world's most complete line of API 610 pumps with the widest range of hydraulic coverage, pressure and temperature capabilities. Our engineering expertise, applications know-how and installation experience are peerless. And, our ability to understand the industry's high-pressure pumping needs is evidenced by our numerous innovative water injection pumps. Designed with an unyielding focus on performance and reliability, Flowserve water injection pumps help our oil and gas customers achieve high uptimes and low total cost of ownership so they can realize their business objectives.

### Committed to the complete pump system lifecycle

Changing water quality and pressure requirements over the lifetime of a well can impact pump performance and well productivity. Oil and gas customers need partners that can help them nimbly respond to dynamic process and business conditions. Flowserve is the right partner for the job.

Our high-energy pump experts can help with equipment upgrades, like corrosion- and/or wear-resistant overlays, that extend pump life and mean time between repair (MTBR). We can perform hydraulic rerates that improve pump performance, reliability and efficiency. And, we can support your on-site teams by meeting operational objectives with broader project planning and turnkey responsibilities.

No matter the need, we leverage our global network of manufacturing facilities, design centers of excellence, and strategically located Quick Response Centers to ensure you get professional, reliable results.



## A foundation of innovation and leadership

Since 1926, when it developed the first double case pump for hot oil, Flowserve has been in the vanguard of pump development for the oil and gas industry. This leadership position was reinforced in 1934 with the introduction of high-pressure water injection pumps and cemented in 1982 when it built one of the world's largest water injection pumps (17,900 kW [24,000 hp]).

Reflecting its leadership position, Flowserve continues to be involved in establishing the API 610 standard governing the construction of these and other pumps for the oil and gas industry.

## Pump designs to meet application needs

Flowserve offers several high-pressure pump designs for water injection service. From axially split, multistage (BB3) units to diffuser- or volute-type double case (BB5) models, Flowserve water injection pumps are built to customer specifications, often exceeding the requirements of API 610.

- **API performance testing** is conducted on each pump prior to shipment.

- **Materials of construction** are chosen to meet service requirements. Selections factor in the salinity, temperature, contaminants and other characteristics of the water. Common options include:

- Carbon steels, chromium steels, austenitic stainless steels, duplex stainless steels and super duplex stainless steels
- For higher pressures or more corrosive applications, wetted components may be carbon steel overlaid with a superior material, such as Inconel®.

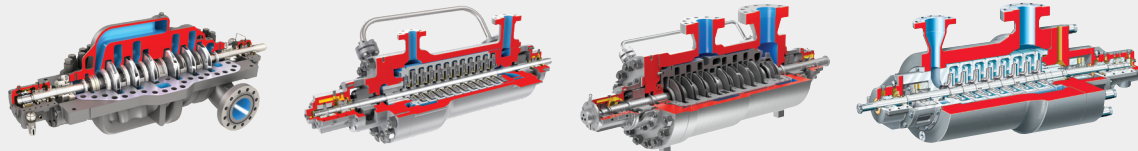

Parameter	DMX	WCC	HSO/HDO	WIK/WIKO
<b>Configuration</b>	API 610 (BB3)	API 610 (BB5); diffuser-style	API 610 (BB5); volute-style	API 610 (BB5); diffuser-style
<b>Flows to</b>	5,678 m <sup>3</sup> /h (25,000 gpm)	1,000 m <sup>3</sup> /h (4,500 US gpm)	4,000 m <sup>3</sup> /h (17,610 gpm)	1,600 m <sup>3</sup> /h (7,000 gpm)
<b>Heads to</b>	2,712 m (8,900 ft)	4,000 m (13,100 ft)	5,500 m (18,000 ft)	7,000 m (23,000 ft)
<b>Pressures to</b>	275 bar (4,000 psi)	300 bar (4,350 psi)	450 bar (6,525 psi)	650 bar (9,425 psi)

® Inconel is a registered trademark of Specialty Metals Corporation.

## DMX

Between bearings, axially split, multistage pump

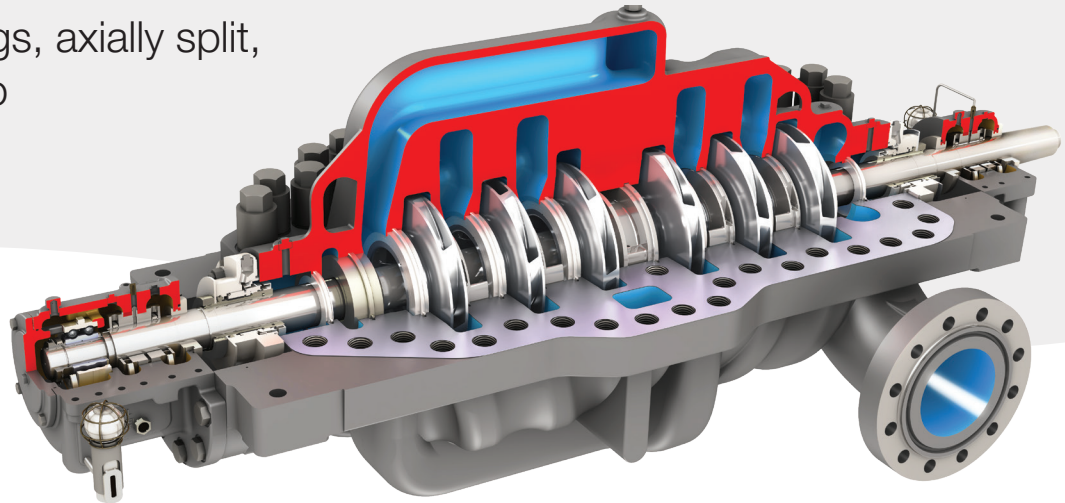

Compliant with API 610 (BB3), latest edition, the Flowserve DMX multistage, axially split pump is engineered and built for long-lasting performance in high-pressure, heavy-duty applications, including water injection. Its comprehensive hydraulic range, along with numerous materials, bearings and lubrication options, allow precise selection to ensure the best hydraulic fit, high operating efficiency and stability for each application. This helps to minimize operating expenses and extend MTBR.

### Operating parameters

- Flows to 5,678 m<sup>3</sup>/h (25,000 gpm)
- Heads to 2,712 m (8,900 ft)
- Pressures to 275 bar (4,000 psi)
- Temperatures to 200°C (400°F)
- Speeds to 6,000 rpm

For parameters outside these limits, please contact Flowserve.

### Features and benefits

**Heavy-duty, axially split casing** features double volutes positioned 180 degrees apart so hydraulically generated radial loads are balanced.

**Opposed impeller configuration** effectively balances axial thrust over a wide range of operating conditions. A double suction first-stage impeller (DMXD) is available for low-NPSH applications.

**Raised face flanges** meet ASME B16.5 dimensional criteria. Class 600 suction and discharge minimum. High-pressure casings and Class 900 and 1500 are also available.

**Nozzles** are integral with the lower half casing, permitting disassembly of the pump without disturbing piping connections. They are designed to handle external forces and moments equal to or in excess of API-specified figures.

**Cap nuts** on the top half casing parting flange allow easy casing removal for inspection and maintenance.

**Split center bushing** enables inspection and dynamic balancing of the rotor without dismantling.

**Replaceable casing and impeller wear rings** control interstage leakage and provide hydraulic stability.



## Hydraulically balanced performance

The DMX pump is engineered to perform reliably at the required hydraulic capacity while mitigating thrust loads. With as many as 14 stages to produce the required hydraulic capacity, the pump's opposed impeller mounting arrangement effectively balances axial thrust over a broad operating range. Its double volute casing ensures hydraulically generated radial thrust loads are offset. Shaft deflection and vibration are virtually eliminated, resulting in prolonged bearing and seal life.

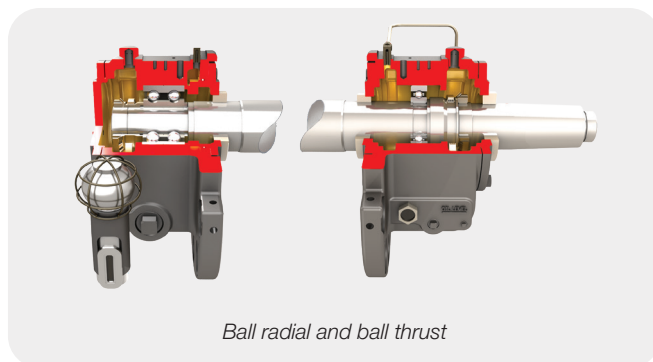

## Robust rotating element

The DMX pump's robust rotating element includes large-diameter shafts and short bearing spans to minimize deflection. Final two-plane dynamic balancing and TIR verifications are conducted on assembled rotors to ensure optimum mechanical performance throughout the operating range. Shaft size is selected to suit power and speed requirements.

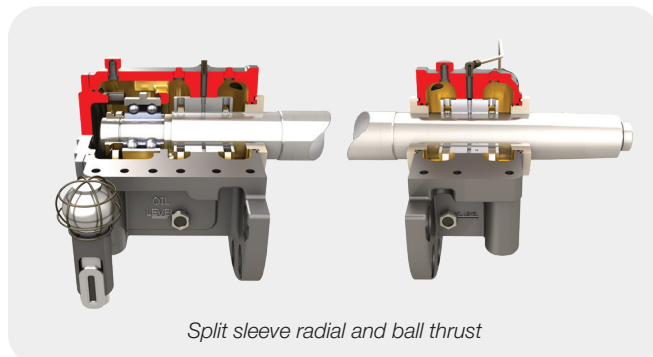

## Multiple bearing designs

The DMX pump is offered with a variety of bearing designs to meet application requirements. The standard radial bearing is a self-aligning, antifriction type. The thrust bearing consists of the two single-row, angular-contact antifriction bearings.

Standard lubrication is via an oil ring system and incorporates a constant-level oiler and a sight glass. This system prolongs bearing life by ensuring oil penetrates the bearings without foaming.

Other bearing designs include the following:

- Split sleeve radial and ball thrust
- Split sleeve radial and tilting pad thrust

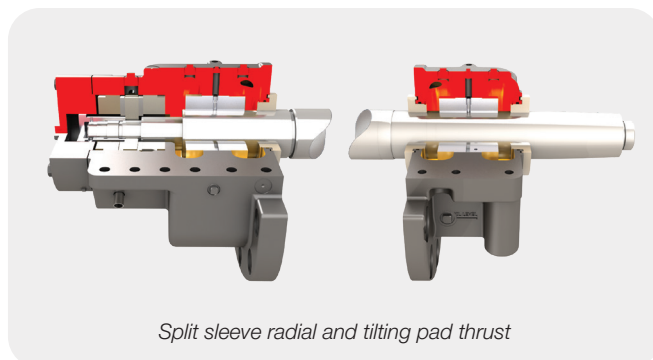

## WCC

High-pressure, medium-duty, diffuser-style, double-case pump

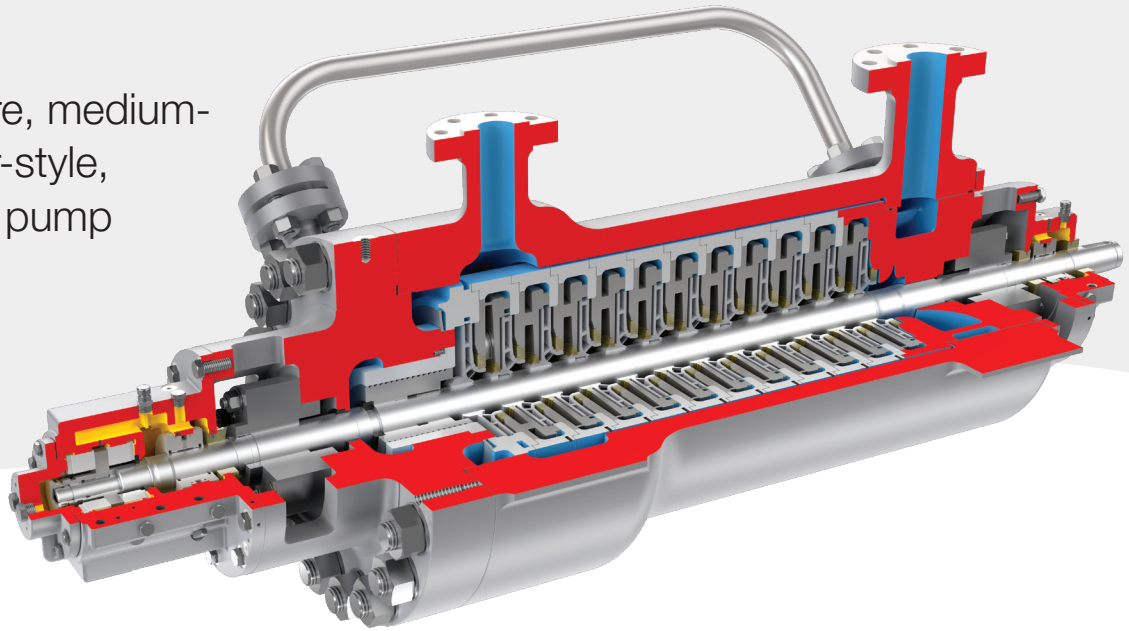

The WCC multistage, diffuser-type barrel pump features a tandem impeller rotor and a single-diameter balance drum to compensate for residual axial thrust. The standard cartridge-type construction facilitates rapid changeout with a spare to minimize lost production. When process requirements demand a fully compliant, API 610 (BB5) pump but also call for a flexible, cost-efficient solution, the WCC pump is the optimum choice. With its extensive list of options and metallurgical choices, it can fit almost any water injection application.

### Operating parameters

- Flows to 1,000 m<sup>3</sup>/h (4,500 US gpm)
- Heads to 4,000 m (13,100 ft)
- Pressure rating to 300 bar (4,350 psi)
- Temperatures from -73°C to 425°C (-100°F to 800°F)
- Speeds to 6,500 rpm

For parameters outside these limits, please contact Flowserve.

### Features and benefits

**Wrought shafts** are incrementally stepped at each impeller fit for ease of assembly. Shafting is generously sized and machined to tight tolerances to minimize vibration.

**Precision-cast impellers** ensure optimum hydraulic efficiency and performance repeatability. Impeller wear surfaces — whether separate wear rings (standard) or integral (optional) — are engineered for the best possible performance. Standard materials can be upgraded with overlay materials like Stellite® or surface treatments like laser hardening for better durability.

**Multi-vane diffusers** balance radial loads over the operating range while maximizing efficiencies at the duty condition. A continuous metal-to-metal seal between stage pieces minimizes risk of internal leakage.

**Seal chambers** are engineered to accommodate cartridge seals using API 682 design criteria. Multiple seal designs are available to meet site-specific requirements.

® Stellite is a registered trademark of Deloro Stellite.

## Single-diameter balance drum

A single-diameter balance drum compensates for residual axial thrust produced by the tandem-impeller arrangement. The drum is designed to be plain or serrated as appropriate for the application to reduce leakage and optimize reliability and efficiency. It is installed via an interference fit against a step in the shaft and located axially with a split ring. A flanged drum design is optional.

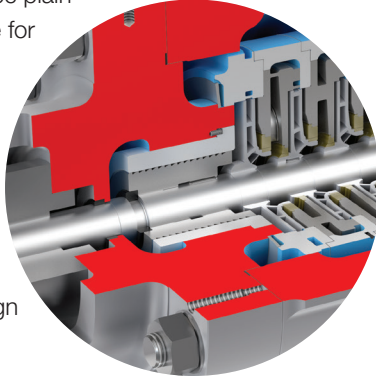

## Optional shear ring closure system

A shear ring closure system is available. In this configuration, the high-strength split seal ring is locked into the barrel body by cap nuts. This design maintains cartridge integrity but allows maintenance with conventional tooling. It also is more compact and boasts one of the quickest maintenance turnarounds in the industry.

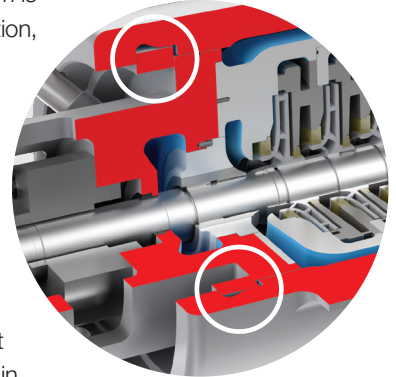

*Shear ring closure system*

## Robust bearing system

The WCC pump is offered with a variety of bearing configurations to meet application requirements. For the most demanding applications, the standard bearing system consists of heavy-duty journal radial bearings and self-equalizing, tilting pad thrust bearings due to their reliability and versatility.

The following bearing arrangements also are available:

- Rolling element thrust bearings may be used in conjunction with either rolling element radial or self-lubricated radial sleeve bearings. Air, fan or water cooling is available as needed to suit the application requirements.
- When space is at a premium, an integral lubrication circulation system can be supplied. This system offers the benefits of circulation while maintaining a compact size and minimizing maintenance demands.

## Barrel pressure rating

All pressure boundary components are designed in accordance with ASME standards to meet the application requirements. The suction portion of the WCC barrel is engineered as a split pressure rated design. Sealing is metal-to-metal with fully confined, controlled compression gaskets that ensure proper sealing and alignment when handling hot liquids.

## Back pullout, cartridge construction

The standard cartridge-type inner element includes the rotor, diffusers, discharge head, suction head and bearing assembly, allowing the entire assembly to be removed as a single unit. This design eases maintenance and reduces downtime. Major assembly, disassembly, and mechanical seal and rotor settings can be performed in the shop, rather than in the field.

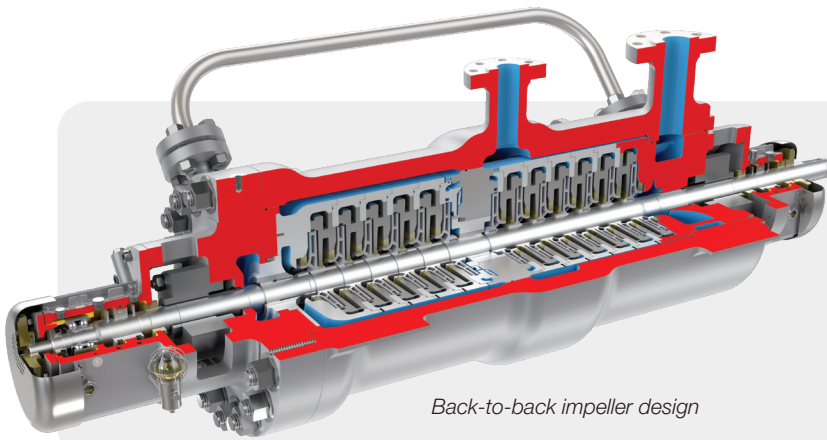

*Back-to-back impeller design*

## Optional back-to-back rotor

An available back-to-back rotor design ensures hydraulic balancing of the axial thrust. The center bushing and sleeve ensure improved rotor dynamics by adding rotor stability and low vibration levels for higher stage counts, even for low-density applications.

## HSO and HDO

High-pressure,  
heavy-duty, volute-style,  
double-case pumps

HDO pump

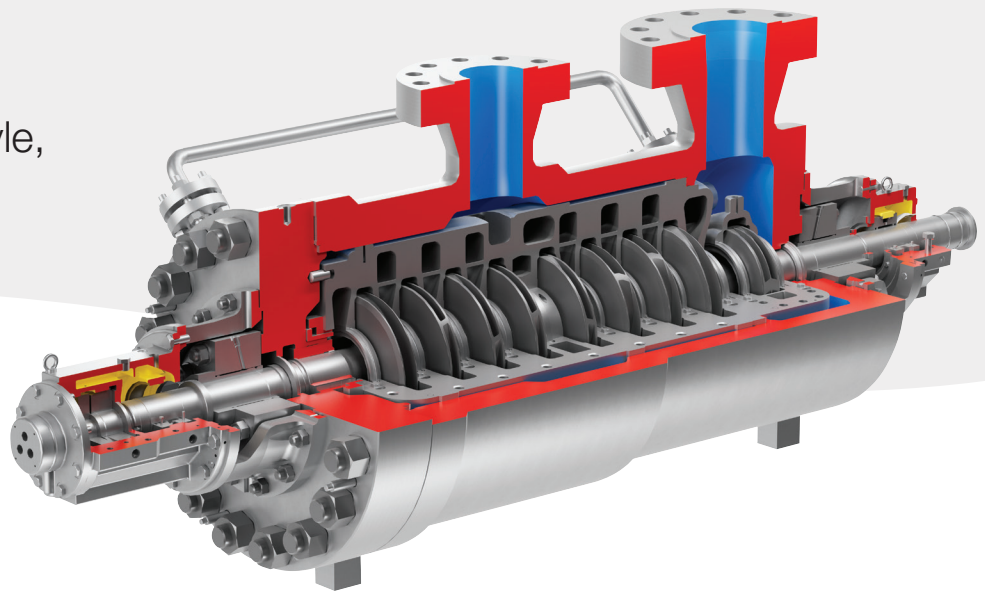

Rated for the most severe water injection conditions, HSO and HDO special purpose pumps are manufactured to the strictest design criteria, often exceeding API 610 (BB5). These pumps feature opposed impellers and dual volute casings, resulting in nearly balanced axial hydraulic thrust and fully balanced radial forces over the full operating range of the pumps.

Standard single-suction (HSO) or optional double-suction (HDO) first-stage impellers provide the flexibility to meet a variety of NPSH requirements.

### Operating parameters

- Flows to 4,000 m<sup>3</sup>/h (17,610 US gpm)
- Heads to 5,500 m (18,000 ft)
- Pressures to 450 bar (6,525 psi)
- Temperatures to 450°C (840°F)
- Speeds to 9,000 rpm

For parameters outside these limits, please contact Flowserve.

### Features and benefits

**Double volute casing** consists of two identical halves with volutes 180 degrees apart. This design essentially balances radial loads at all operational points, reducing harmful vibration and ensuring dependable performance.

**Split-construction stage pieces** ease installation in the volute casing.

**Precision-cast impellers** improve hydraulic efficiency and performance. Impellers are secured with split rings and a shrink fit to prevent axial movement.

**Dynamically balanced rotor** provides excellent rotor dynamic stability and is balanced as a complete unit before installation.

**Center stage piece** breaks down 50% of the discharge pressure to the intermediate stage before the long crossover. It is overlaid with a hard wear surface to eliminate damage from the mating impeller wear surfaces.

**Optional grooved impeller running fits** increase the pump's tolerance to foreign materials and desensitize it during startup, stopping and system transients.

**Wrought shafts** are incrementally stepped at each impeller fit for ease of assembly. The standard shaft extension is a NEMA taper.



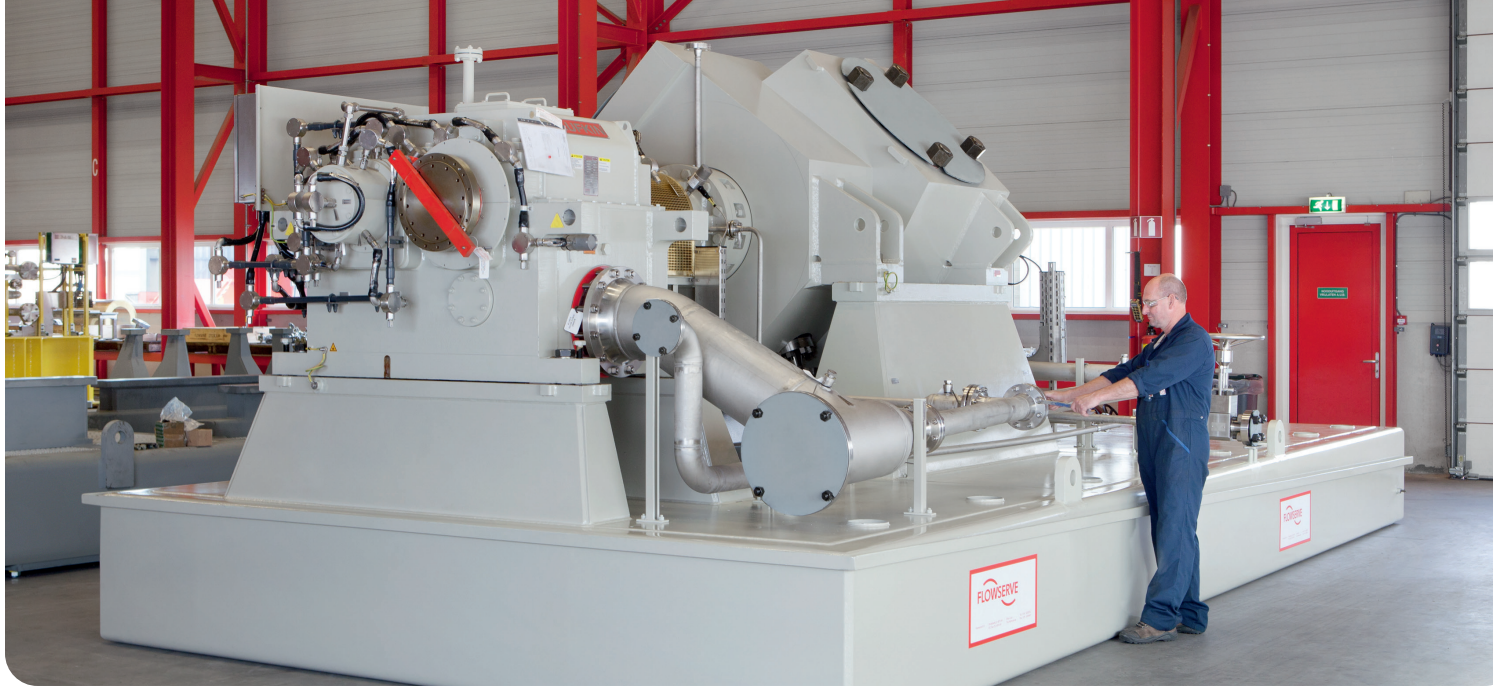

### Sag boring prolongs wear ring life

Sag boring may be applied to all volutes nine stages and higher. The bottom volute casing is bored in incremental steps toward the center. This design accommodates the static deflection of the rotating assembly caused by its own weight when the pump is not operating. During startup, the shaft will straighten and casing rings will slide upward to maintain clearances. This process eliminates rubbing of wear rings commonly found with slender shaft and high stage counts.

### Rated for maximum safety

The barrel casing and discharge cover house the pump inner bundle, which is a full discharge pressure-rated design for higher reliability and safety.

The bolted discharge cover features only one high-pressure, fully confined, circular compression gasketed sealing joint to the atmosphere for superior reliability.

### Volute locating ring improves reliability

HSO and HDO pumps employ a volute locating ring to position and secure the discharge cover and volute in place. This design reduces vibration and alignment issues, and ensures safe, reliable operation.

### Numerous nozzle configurations

Nozzles on HSO and HDO pumps have standard raised face flanges. Nozzle orientation can be adjusted to suit site requirements. Weld-end, ring joint, and tongue and groove flanges are optional.

### Robust bearing system

Sleeve journal radial bearings and tilting pad thrust bearings are standard, utilizing either air or water cooling as needed. Duplex ball and sleeve/ball thrust bearings are available where appropriate and permitted by API 610 (BB5).

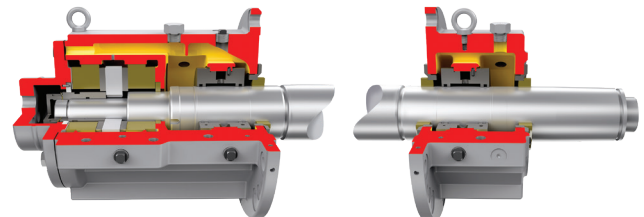

*Standard split sleeve radial and tilting pad thrust*

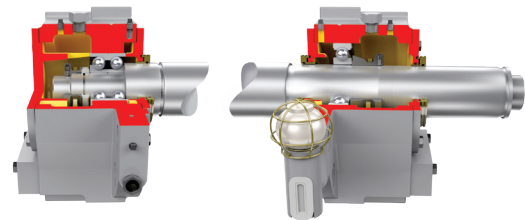

*Ball radial and ball thrust*

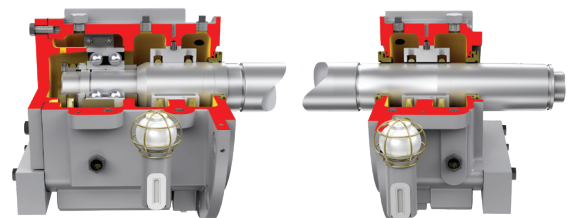

*Split sleeve radial and ball thrust*

## WIK and WIKO

High-pressure, heavy-duty  
diffuser-style,  
double-case pumps

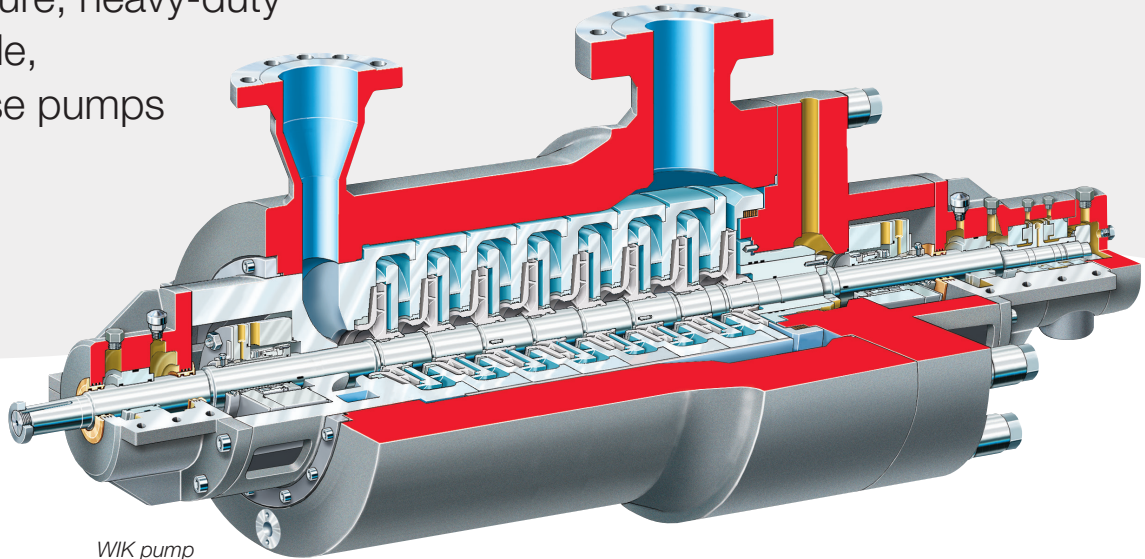

WIK pump

The uncompromising engineering philosophy adopted by Flowserve engineers when designing the WIK and WIKO pumps resulted in diffuser-style pumps that are unmatched in the industry. The WIK pump features a tandem (in-line) impeller rotor. The WIKO pump is the opposed impeller variation, capable of handling ultra-high injection pressures. They are ideal for unspared, high-power density and extremely arduous applications. They include superior rotor dynamics, unequaled mechanical design, and proven records of experience in water injection service. Both are designed and built to meet or exceed API 610 (BB5), latest edition, and custom-engineered to stringent customer requirements.

### Typical operating parameters

- Flows to 1,600 m<sup>3</sup>/h (7,000 gpm)
- Heads to 7,000 m (23,000 ft)
- Pressures
  - WIK: 650 bar (9,425 psi)
  - WIKO: 800 bar (11,603 psi)
- Temperatures to 450°C (840°F)
- Speeds to 9,000 rpm

For parameters outside these limits, please contact Flowserve.

### Features and benefits

**High-stiffness rotor** with low static deflection is the result of large-diameter shaft and short bearing spans. This reduces the risk of accidental contact within the running clearances and improves the pump's tolerance to operational upsets.

**Multi-vane, radially split diffuser and channel ring collectors** are cast components, eliminating radial imbalance across the entire operating range. Collectors provide continuous metal-to-metal sealing between stages and also between inner and outer casings. Collectors are milled to create smooth passageways and ensure repeatability of performance.

**Large-diameter shafts** are incrementally stepped at all of the impeller, seal and thrust collar fits for ease of assembly. Shafts are thermally stabilized to eliminate potential distortion from residual stresses.

**Heavy-duty tilting pad thrust bearings** are leading edge groove (LEG) pressure-lubricated, self-equalizing type.

**Mechanical seals** are contained within a large-diameter seal chamber designed to API 682. Multiple seal designs are available.

**Forged barrel casing and discharge head** are precision designed for each application and manufactured from high-strength forgings to ensure unparalleled durability.

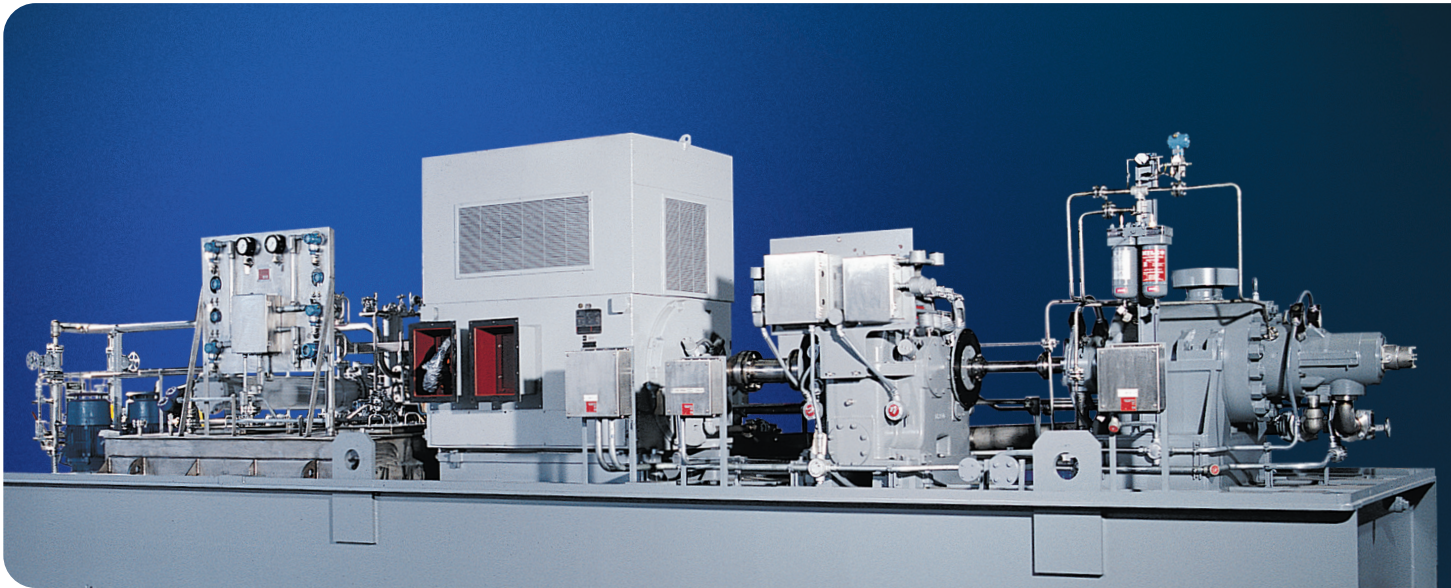

### Unique low specific speed impellers

Precision-cast low specific speed impellers are statically and dynamically balanced. Impellers are double keyed and positively secured against axial movement by split rings and a shrink-fit on a stepped shaft. Large eye, single-suction or alternate double-suction, first-stage impellers are available depending on NPSH conditions. Impeller hubs have integral hardened wear surfaces.

### Single-diameter balance drum

The single-diameter balance drum compensates for the residual axial thrust produced by the tandem impeller arrangement. The sleeve is grooved against the flow to improve rotor stability, lower balancing leak-off flow, and reduce the risk of galling in the running clearance. It is mounted with a shrink-fit key driven and located with a split ring.

### Back pullout, cartridge construction

The standard cartridge-style inner case subassembly includes the rotor, diffusers, discharge head, suction head, seals and bearing assemblies. This design eases maintenance by allowing quick replacement of the entire subassembly. Major assembly, disassembly, and mechanical seal and rotor settings can then be performed in the shop, rather than in the field.

### WIKO: Innovative opposed impeller design for ultra-high pressures

The WIKO pump was developed to meet ever-increasing customer requirements for extreme discharge pressures and the need to balance residual axial thrust. By pairing an opposed impeller rotor with diffuser collectors and a single-diameter balance drum, this design can be customized to meet higher pressures.

Every WIKO pump is custom designed and built to order for specific ultra high-pressure applications.

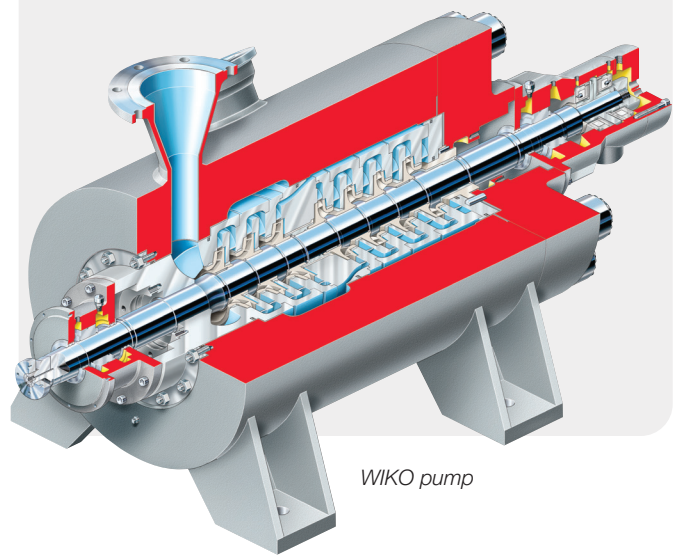

WIKO pump



## Increase uptime with predictive maintenance

Flowserve water injection pumps are RedRaven Ready. RedRaven is a predictive maintenance service from Flowserve that improves plant performance by detecting anomalies in pumps, valves and seals. It enables you to predict when and why your critical assets may experience issues so you can take preventive action.

RedRaven is a complete end-to-end proactive maintenance solution. It enables you to leverage the internet of things (IoT) for a connected platform of smart products, software and services. It gives you the tools you need to monitor, analyze and predict the performance of your pumps, seals and valves, as well as the insights you need to make more informed decisions for improving your plant's reliability, efficiency, productivity and bottom line.

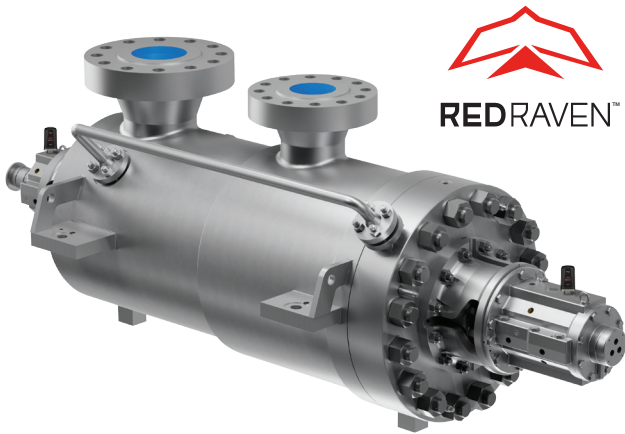

### A ready-to-deploy, scalable solution

Most Flowserve fluid motion and control equipment is RedRaven Ready. That means it's designed and built to accept RedRaven wired or wireless sensors using cloud architecture for condition monitoring and predictive analytics services.

RedRaven Ready pumps, seals and valves securely connect to an IoT platform that includes hazardous area-certified equipment sensors, secure communication, performance analytics and trend reporting tools — all tailored to your plant's unique needs.

Options include:

**Condition monitoring:** Enables you to capture asset performance data for analysis

**Predictive analytics:** Applies data analysis software and algorithms to help you identify and diagnose equipment problems

For more information on RedRaven, contact your Flowserve representative or visit [www.flowserve.com/redraven](http://www.flowserve.com/redraven)

Flowserve Corporation  
5215 North O'Connor Blvd.  
Suite 700  
Irving, Texas 75039-5421 USA

Flowserve Corporation has established industry leadership in the design and manufacture of its products. When properly selected, this Flowserve product is designed to perform its intended function safely during its useful life. However, the purchaser or user of Flowserve products should be aware that Flowserve products might be used in numerous applications under a wide variety of industrial service conditions. Although Flowserve can provide general guidelines, it cannot provide specific data and warnings for all possible applications. The purchaser/user must therefore assume the ultimate responsibility for the proper sizing and selection, installation, operation, and maintenance of Flowserve products. The purchaser/user should read and understand the Installation Instructions included with the product, and train its employees and contractors in the safe use of Flowserve products in connection with the specific application.

While the information and specifications contained in this literature are believed to be accurate, they are supplied for informative purposes only and should not be considered certified or as a guarantee of satisfactory results by reliance thereon. Nothing contained herein is to be construed as a warranty or guarantee, express or implied, regarding any matter with respect to this product. Because Flowserve is continually improving and upgrading its product design, the specifications, dimensions and information contained herein are subject to change without notice. Should any question arise concerning these provisions, the purchaser/user should contact Flowserve Corporation at any one of its worldwide operations or offices.

©2023 Flowserve Corporation. All rights reserved. This document contains registered and unregistered trademarks of Flowserve Corporation. Other company, product, or service names may be trademarks or service marks of their respective companies.

PUBR000068-05 (EN/AQ) July 2023