



USER INSTRUCTIONS

CPXVC

Vertical cantilever, centrifugal sump pumps

PCN=26999930 03-17 (E) Original instructions

Installation
Operation
Maintenance



 ***These instructions must be read prior to installing, operating, using and maintaining this equipment.***

Experience In Motion

CONTENTS

	Page		Page
1 INTRODUCTION AND SAFETY	4	6 MAINTENANCE	18
1.1 General	4	6.1 General.....	18
1.2 CE marking and approvals	4	6.2 Maintenance schedule	19
1.3 Disclaimer	4	6.3 Spare parts.....	20
1.4 Copyright	4	6.4 Recommended spares	20
1.5 Duty conditions	4	6.5 Tools required	20
1.6 Safety.....	5	6.6 Casing, seal housing and fastener torques.....	20
1.7 Nameplate and safety labels	8	6.7 Setting impeller clearance.....	21
1.8 Specific machine performance	9	6.8 Renewal clearances.....	21
1.9 Noise level	9	6.9 Disassembly.....	21
2 TRANSPORT AND STORAGE	10	6.10 Examination of parts	22
2.1 Consignment receipt and unpacking	10	6.11 Assembly.....	22
2.2 Handling.....	10	7 FAULTS; CAUSES AND REMEDIES	25
2.3 Lifting	10	8 PARTS LISTS AND DRAWINGS	27
2.4 Storage	10	8.1 CPXVC	27
2.5 Recycling and end of product life	10	8.2 General arrangement drawing	28
3 DESCRIPTION	11	9 CERTIFICATION.....	29
3.1 Configurations.....	11	10 OTHER RELEVANT DOCUMENTATION AND	
3.2 Name nomenclature	11	MANUALS.....	29
3.3 Design of major parts.....	11	10.1 Supplementary User Instruction manuals ...	29
3.4 Performance and operating limits.....	11	10.2 Change notes	29
4 INSTALLATION.....	12	10.3 Additional sources of information	29
4.1 Location	12		
4.2 Part assemblies	12		
4.3 Foundation.....	12		
4.4 Grouting	12		
4.5 Piping.....	12		
4.6 Electrical connections.....	14		
4.7 Protection systems	14		
5 COMMISSIONING, START-UP, OPERATION AND			
SHUTDOWN	15		
5.1 Pre-commissioning procedure.....	15		
5.2 Pump lubricants	15		
5.3 Recessed impeller clearance	16		
5.4 Direction of rotation	16		
5.5 Guarding	16		
5.6 Priming and auxiliary supplies	16		
5.7 Starting the pump	16		
5.8 Running the pump	17		
5.9 Stopping and shutdown	18		
5.10 Hydraulic, mechanical and electrical duty ..	18		

INDEX

Page	Page		
Additional sources (10.3).....	38	Reassembly (6.11, Assembly)	24
Assembly (6.11).....	24	Receipt and unpacking (2.1)	9
ATEX marking (1.6.4.2)	7	Recommended fill quantities (see 5.2.2).....	16
Bearing sizes and capacities (5.2.2).....	16	Recommended grease lubricants (5.2.3)	16
CE marking and approvals (1.2).....	4	Recommended oil lubricants (5.2.1)	16
Certification (9)	38	Recommended spares (6.4).....	21
Change notes (10.2)	38	Recycling (2.5)	11
Clearances, impeller (6.7)	22	Replacement parts (6.3 and 6.4).....	21
Commissioning and operation (5).....	15	Running the pump (5.8)	18
Compliance, ATEX (1.6.4.1).....	6	Safety action (1.6.3)	5
Configurations (3.1)	11	Safety labels (1.7.2)	9
Copyright (1.4)	4	Safety markings (1.6.1)	5
Design of major parts (3.3)	11	Safety, protection systems (1.6 and 4.7)	
Direction of rotation (5.4)	17	Sectional drawings (8).....	29
Disassembly (6.9)	23	Setting impeller clearance (6.7)	22
Disclaimer (1.3).....	4	Sound pressure level (1.9, Noise level)	9
Dismantling (6.9, Disassembly)	23	Sources, additional information (10.3)	38
Drawings (8)	29	Spare parts (6.3)	21
Duty conditions (1.5).....	4	Specific machine performance (1.8)	9
Electrical connections (4.6)	14	Starting the pump (5.7).....	17
End of product life (2.5)	11	Stop/start frequency (5.8.5).....	18
Examination of parts (6.10)	24	Stopping and shutdown (5.9)	19
Fastener torques (6.6)	22	Storage, pump (2.4)	11
Faults; causes and remedies (7)	27	Storage, spare parts (6.3.2)	21
Foundation (4.3)	12	Supplementary manuals or information sources.....	38
General arrangement drawing (8.7)	37	Supplementary User Instructions (10.1).....	38
General assembly drawings (8).....	29	Tools required (6.5).....	21
Grouting (4.4).....	12	Torques for fasteners (6.6).....	22
Guarding (5.5).....	17	Trouble-shooting (see 7)	27
Handling (2.2)	9	Vibration (5.8.4).....	18
Hydraulic, mechanical and electrical duty (5.10).....	19		
Impeller clearance (5.3 and 6.7)			
Inspection (6.2.1 and 6.2.2).....	20/21		
Installation (4)	12		
Lifting (2.3).....	10		
Location (4.1).....	12		
Lubrication (5.1.1, 5.2 and 6.2.3)			
Lubrication schedule (5.2.5)	16		
Maintenance (6).....	19		
Maintenance schedule (6.2)	20		
Name nomenclature (3.2).....	11		
Nameplate (1.7.1)	9		
Operating limits (3.4.1)	12		
Ordering spare parts (6.3.1)	21		
Part assemblies (4.2).....	12		
Parts lists (8).....	29		
Performance (3.4).....	11		
Piping (4.5)	12		
Pre-commissioning (5.1).....	15		
Priming and auxiliary supplies (5.6).....	17		
Protection systems (4.7).....	14		

1 INTRODUCTION AND SAFETY

1.1 General

 ***These instructions must always be kept close to the product's operating location or directly with the product.***

Flowserve products are designed, developed and manufactured with state-of-the-art technologies in modern facilities. The unit is produced with great care and commitment to continuous quality control, utilising sophisticated quality techniques, and safety requirements.

Flowserve is committed to continuous quality improvement and being at service for any further information about the product in its installation and operation or about its support products, repair and diagnostic services.

These instructions are intended to facilitate familiarization with the product and its permitted use. Operating the product in compliance with these instructions is important to help ensure reliability in service and avoid risks. The instructions may not take into account local regulations; ensure such regulations are observed by all, including those installing the product. Always coordinate repair activity with operations personnel, and follow all plant safety requirements and applicable safety and health laws and regulations.

 ***These instructions must be read prior to installing, operating, using and maintaining the equipment in any region worldwide. The equipment must not be put into service until all the conditions relating to safety, noted in the instructions, have been met. Failure to follow and apply the present user instructions is considered to be misuse. Personal injury, product damage, delay or failure caused by misuse are not covered by the Flowserve warranty.***

1.2 CE marking and approvals

It is a legal requirement that machinery and equipment put into service within certain regions of the world shall conform with the applicable CE Marking Directives covering Machinery and, where applicable, Low Voltage Equipment, Electromagnetic Compatibility (EMC), Pressure Equipment Directive (PED) and Equipment for Potentially Explosive Atmospheres (ATEX).

Where applicable, the Directives and any additional Approvals, cover important safety aspects relating to machinery and equipment and the satisfactory provision of technical documents and safety instructions.

Where applicable this document incorporates information relevant to these Directives and Approvals.

To confirm the Approvals applying and if the product is CE marked, check the serial number plate markings and the Certification. (See section 9, *Certification*.)

1.3 Disclaimer

Information in these User Instructions is believed to be complete and reliable. However, in spite of all of the efforts of Flowserve Corporation to provide comprehensive instructions, good engineering and safety practice should always be used.

Flowserve manufactures products to exacting International Quality Management System Standards as certified and audited by external Quality Assurance organisations. Genuine parts and accessories have been designed, tested and incorporated into the products to help ensure their continued product quality and performance in use. As Flowserve cannot test parts and accessories sourced from other vendors the incorrect incorporation of such parts and accessories may adversely affect the performance and safety features of the products. The failure to properly select, install or use authorised Flowserve parts and accessories is considered to be misuse. Damage or failure caused by misuse is not covered by the Flowserve warranty. In addition, any modification of Flowserve products or removal of original components may impair the safety of these products in their use.

1.4 Copyright

All rights reserved. No part of these instructions may be reproduced, stored in a retrieval system or transmitted in any form or by any means without prior permission of Flowserve.

1.5 Duty conditions

This product has been selected to meet the specifications of your purchaser order. The acknowledgement of these conditions has been sent separately to the Purchaser. A copy should be kept with these instructions.

 ***The product must not be operated beyond the parameters specified for the application. If there is any doubt as to the suitability of the product for the application intended, contact Flowserve for advice, quoting the serial number.***

If the conditions of service on your purchase order are going to be changed (for example liquid pumped, temperature or duty) it is requested that the user seeks the written agreement of Flowserve before start up.

1.6 Safety

1.6.1 Summary of safety markings

These User Instructions contain specific safety markings where non-observance of an instruction would cause hazards. The specific safety markings are:

 **DANGER** This symbol indicates electrical safety instructions where non-compliance will involve a high risk to personal safety or the loss of life.

 This symbol indicates safety instructions where non-compliance would affect personal safety and could result in loss of life.

 This symbol indicates “hazardous and toxic fluid” safety instructions where non-compliance would affect personal safety and could result in loss of life.

 **CAUTION** This symbol indicates safety instructions where non-compliance will involve some risk to safe operation and personal safety and would damage the equipment or property.

 This symbol indicates explosive atmosphere zone marking according to ATEX. It is used in safety instructions where non-compliance in the hazardous area would cause the risk of an explosion.

 This symbol is used in safety instructions to remind not to rub non-metallic surfaces with a dry cloth; ensure the cloth is damp. It is used in safety instructions where non-compliance in the hazardous area would cause the risk of an explosion.

Note: This sign is not a safety symbol but indicates an important instruction in the assembly process.

1.6.2 Personnel qualification and training

All personnel involved in the operation, installation, inspection and maintenance of the unit must be qualified to carry out the work involved. If the personnel in question do not already possess the necessary knowledge and skill, appropriate training and instruction must be provided. If required the operator may commission the manufacturer/supplier to provide applicable training.

Always coordinate repair activity with operations and health and safety personnel, and follow all plant safety requirements and applicable safety and health laws and regulations.

1.6.3 Safety action

This is a summary of conditions and actions to help prevent injury to personnel and damage to the environment and to equipment. For products used in potentially explosive atmospheres section 1.6.4 also applies.

 **DANGER** NEVER DO MAINTENANCE WORK WHEN THE UNIT IS CONNECTED TO POWER

 **GUARDS MUST NOT BE REMOVED WHILE THE PUMP IS OPERATIONAL**

 **DRAIN THE PUMP AND ISOLATE PIPEWORK BEFORE DISMANTLING THE PUMP**

The appropriate safety precautions should be taken where the pumped liquids are hazardous.

 **FLUORO-ELASTOMERS** (When fitted.) When a pump has experienced temperatures over 250 °C (482 °F), partial decomposition of fluoro-elastomers (example: Viton) will occur. In this condition these are extremely dangerous and skin contact must be avoided.

 **HANDLING COMPONENTS** Many precision parts have sharp corners and the wearing of appropriate safety gloves and equipment is required when handling these components. To lift heavy pieces above 25 kg (55 lb) use a crane appropriate for the mass and in accordance with current local regulations.

 **THERMAL SHOCK** Rapid changes in the temperature of the liquid within the pump can cause thermal shock, which can result in damage or breakage of components and should be avoided.

 **NEVER APPLY HEAT TO REMOVE IMPELLER** Trapped lubricant or vapor could cause an explosion.

 **HOT (and cold) PARTS** If hot or freezing components or auxiliary heating supplies can present a danger to operators and persons entering the immediate area action must be taken to avoid accidental contact. If complete protection is not possible, the machine access must be limited to maintenance staff only, with clear visual warnings and indicators to those entering the immediate area. Note: bearing housings must not be insulated and drive motors and bearings may be hot.

If the temperature is greater than 80 °C (175 °F) or below -5 °C (23 °F) in a restricted zone, or exceeds local regulations, action as above shall be taken.



HAZARDOUS LIQUIDS

When the pump is handling hazardous liquids care must be taken to avoid exposure to the liquid by appropriate siting of the pump, limiting personnel access and by operator training. If the liquid is flammable and/or explosive, strict safety procedures must be applied.

Gland packing must not be used when pumping hazardous liquids.



CAUTION PREVENT EXCESSIVE EXTERNAL PIPE LOAD

Do not use pump as a support for piping. Do not mount expansion joints, unless allowed by Flowserve in writing, so that their force, due to internal pressure, acts on the pump flange.

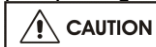

CAUTION NEVER RUN THE PUMP DRY

Liquid level controls are recommended to avoid the risk of dry running.

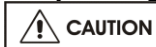

CAUTION ENSURE CORRECT LUBRICATION

(See section 5, *Commissioning, startup, operation and shutdown.*)



CAUTION ONLY CHECK DIRECTION OF MOTOR ROTATION WITH COUPLING ELEMENT/ PINS REMOVED

Starting in reverse direction of rotation will damage the pump.

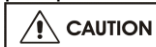

CAUTION START THE PUMP WITH OUTLET VALVE PART OPENED

(Unless otherwise instructed at a specific point in the User Instructions.)

This is recommended to minimize the risk of overloading and damaging the pump or motor at full or zero flow. Pumps may be started with the valve further open only on installations where this situation cannot occur. The pump outlet control valve may need to be adjusted to comply with the duty following the run-up process. (See section 5, *Commissioning start-up, operation and shutdown.*)



CAUTION DO NOT RUN THE PUMP AT ABNORMALLY HIGH OR LOW FLOW RATES

Operating at a flow rate higher than normal or at a flow rate with no back pressure on the pump may overload the motor and cause cavitation. Low flow rates may cause a reduction in pump/bearing life, overheating of the pump, instability and cavitation/vibration.

1.6.4 Products used in potentially explosive atmospheres



Measures are required to:

- Avoid excess temperature
- Prevent build up of explosive mixtures
- Prevent the generation of sparks
- Prevent leakages
- Maintain the pump to avoid hazard

The following instructions for pumps and pump units when installed in potentially explosive atmospheres must be followed to help ensure explosion protection. For ATEX, both electrical and non-electrical equipment must meet the requirements of European Directive 2014/34/EU. Always observe the regional legal Ex requirements eg Ex electrical items outside the EU may be required certified to other than ATEX eg IECEx, UL.

1.6.4.1 Scope of compliance



Use equipment only in the zone for which it is appropriate. Always check that the driver, drive coupling assembly, seal and pump equipment are suitably rated and/or certified for the classification of the specific atmosphere in which they are to be installed.

Where Flowserve has supplied only the bare shaft pump, the Ex rating applies only to the pump. The party responsible for assembling the ATEX pump set shall select the coupling, driver and any additional equipment, with the necessary CE Certificate/ Declaration of Conformity establishing it is suitable for the area in which it is to be installed.

The motor, coupling, pump thrust bearing and seal can be made compliant with 2014/34/EU ATEX Directive for Equipment Categories 2 and 3 as required by the duty conditions.

See the pump nameplate and Declaration of Conformity for the pump classification.

Users must pay particular attention to pump operation and maintenance instructions because of the hazard of the explosive atmosphere.

The output from a variable frequency drive (VFD) can cause additional heating effects in the motor and so, for pump sets with a VFD, the ATEX Certification for the motor must state that it covers the situation where electrical supply is from the VFD. This particular requirement still applies even if the VFD is in a safe area.

1.6.4.2 Marking

An example of ATEX equipment marking is shown below. The actual classification of the pump will be engraved on the nameplate.

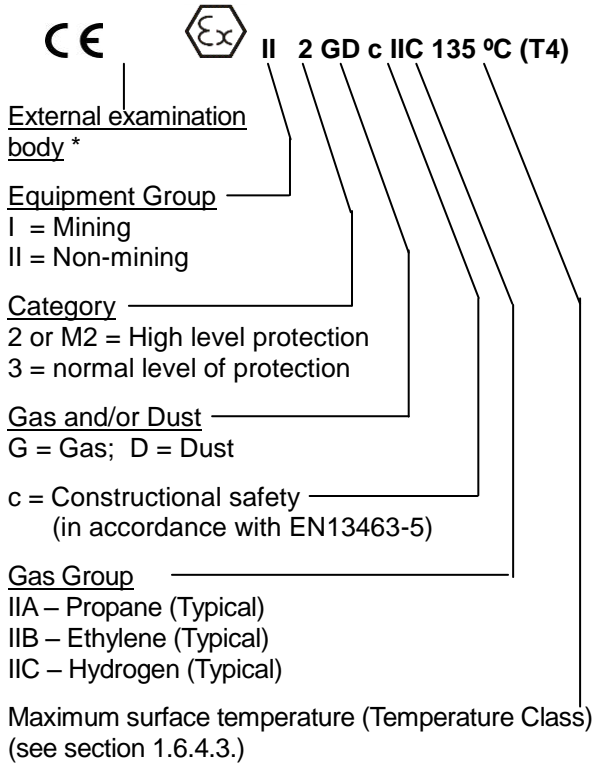

1.6.4.3 Avoiding excessive surface temperatures

ENSURE THE EQUIPMENT TEMPERATURE CLASS IS SUITABLE FOR THE HAZARD ZONE

Pumps have a temperature class as stated in the ATEX Ex rating on the nameplate. These are based on an ambient in the range of -80 to +55 °C (-112 to +131 °F); refer to Flowserve for ambient temperatures outside this range for this product.

The surface temperature on the pump is influenced by the temperature of the liquid handled. The maximum permissible liquid temperature depends on the ATEX temperature class and must not exceed the values in the table that follows.

Temperature class to EN 13463-1	Maximum surface temperature permitted	Temperature limit of liquid handled
T6	85 °C (185 °F)	Consult Flowserve
T5	100 °C (212 °F)	Consult Flowserve
T4	135 °C (275 °F)	115 °C (239 °F) *
T3	200 °C (392 °F)	180 °C (356 °F) *
T2	300 °C (572 °F)	275 °C (527 °F) *
T1	450 °C (842 °F)	400 °C (752 °F) *

* The table only takes the ATEX temperature class into consideration. Pump design or material, as well as component design or material, may further limit the maximum working temperature of the liquid.

The temperature rise at the seals and bearings and due to the minimum permitted flow rate is taken into account in the temperatures stated.

The responsibility for compliance with the specified maximum liquid temperature is with the plant operator.

Temperature classification “Tx” is used when the liquid temperature varies and when the pump is required to be used in differently classified potentially explosive atmospheres. In this case the user is responsible for ensuring that the pump surface temperature does not exceed that permitted in its actual installed location.

Do not attempt to check the direction of rotation with the coupling element/pins fitted due to the risk of severe contact between rotating and stationary components.

Where there is any risk of the pump being run against a closed valve generating high liquid and casing external surface temperatures fit an external surface temperature protection device.

Avoid mechanical, hydraulic or electrical overload by using motor overload trips, a temperature or power monitor and make routine vibration monitoring checks.

In dirty or dusty environments, make regular checks and remove dirt from areas around close clearances, bearing housings and motors.

The equipment utilises polymer based seals and bearing surfaces that could be corroded if they are in contact with unsuitable liquids or gases. These surfaces are important for the operation of the pump. Contact Flowserve if you are uncertain about the performance of these materials with respect to aggressive substances that may be present in the hazardous area.

The pump casing must be flooded with liquid to the minimum level on the dimensional General Arrangement (GA) drawing, at any time that the pump is operated.

1.6.4.4 Preventing the build up of explosive mixtures

ENSURE THE PUMP IS PROPERLY FILLED AND VENTED AND DOES NOT RUN DRY

Ensure the pump and relevant suction and discharge pipeline system is totally filled with liquid at all times during the pump operation, so that an explosive atmosphere is prevented. In addition it is essential to make sure that seal chambers, auxiliary shaft seal systems and any heating and cooling systems are properly filled.

If the operation of the system cannot avoid this condition, fit an appropriate dry run protection device (for example liquid detection or a power monitor).

To avoid potential hazards from fugitive emissions of vapor or gas to atmosphere the surrounding area must be well ventilated.

1.6.4.5 Preventing sparks

To prevent a potential hazard from mechanical contact, the coupling guard must be non-sparking and anti-static for Category 2.

To avoid the potential hazard from random induced current generating a spark, the baseplate must be properly grounded.

Avoid electrostatic charge: do not rub non-metallic surfaces with a dry cloth; ensure cloth is damp.

For ATEX the coupling must be selected to comply with the requirements of European Directive 2014/34/EU. Correct coupling alignment must be maintained.

1.6.4.6 Preventing leakage

The pump must only be used to handle liquids for which it has been approved to have the correct corrosion resistance.

Avoid entrapment of liquid in the pump and associated piping due to closing of suction and discharge valves, which could cause dangerous excessive pressures to occur if there is heat input to the liquid. This can occur if the pump is stationary or running.

Bursting of liquid containing parts due to freezing must be avoided by draining or protecting the pump and ancillary systems.

Where there is the potential hazard of a loss of a seal barrier fluid or external flush, the fluid must be monitored.

If leakage of liquid to atmosphere can result in a hazard, install a liquid detection device

1.6.4.7 Maintenance to avoid the hazard

CORRECT MAINTENANCE IS REQUIRED TO AVOID POTENTIAL HAZARDS WHICH GIVE A RISK OF EXPLOSION

The responsibility for compliance with maintenance instructions is with the plant operator.

To avoid potential explosion hazards during maintenance, the tools, cleaning and painting materials used must not give rise to sparking or adversely affect the ambient conditions. Where there is a risk from such tools or materials, maintenance must be conducted in a safe area.

It is recommended that a maintenance plan and schedule is adopted. (See section 6, *Maintenance*.)

1.7 Nameplate and safety labels

1.7.1 Nameplate

For details of nameplate, see the *Declaration of Conformity*. Where a unit is ATEX Group II Category 1 below the soleplate there is an additional ATEX marking plate (see section 1.6.4.2 *Marking*).

1.7.2 Safety labels

FLOWSERVE		WARNING	J218JZ250
ESSENTIAL PROCEDURES BEFORE STARTING:			
INSTALL AND OPERATE EQUIPMENT IN ACCORDANCE WITH THE INSTRUCTION MANUAL SUPPLIED SEPARATELY.	ENSURE ALL EXTERNAL CONNECTIONS TO THE PUMP / SHAFT SEALING AND DRIVER ARE CONNECTED AND OPERATIONAL.	FULLY PRIME UNIT AND SYSTEM. DO NOT RUN UNIT DRY.	
ENSURE GUARDS ARE SECURELY IN PLACE.	FAILURE TO FOLLOW THESE PROCEDURES MAY RESULT IN PERSONAL INJURY AND / OR EQUIPMENT DAMAGE		
ENSURE CORRECT DIRECTION OF ROTATION.			

J218JZ265	
ENSURE CORRECT DRIVER DIRECTION OF ROTATION WITH COUPLING ELEMENT / PINS REMOVED: OTHERWISE SERIOUS DAMAGE MAY RESULT.	KONTROLLE VORGESCHRIEBENER DREHRICHTUNG ! HIERZU KUPPLUNGSZWISCHENSTÜCK / KUPPLUNGSBOLZEN ENTFERNEN. ANDERENFALLS ERNSTHAFTE SCHÄDEN !
VERIFIER LE SENS CORRECT DE ROTATION DU MOTEUR. POMPE DESACCOUPLEE / ENTRETOISE DEMONTEE. NE PAS SUIVRE CETTE RECOMMANDATION PEUT CONDUIRE A DE GRAVES DOMMAGES POUR LA POMPE	ZORG VOOR JUISTE ROTATIERICHTING VAN DRIJFAS WAARBIJ DE KOPPELELEMENTEN / PENNEN VERWIJDERD ZIJN: VERZUM KAN ERNSTIGE SCHADE TOT GEVOLG HEBBEN.
CDC: 603 604 610 612 621 623 624	

Oil lubricated units only:

J218JZ262	
WARNING	THIS MACHINE MUST BE FILLED WITH OIL BEFORE STARTING
ATTENTION	CETTE MACHINE DOIT ÊTRE REMPLIE D'HUILE AVANT LA MISE EN MARCHÉ
ACHTUNG	DIESE MASCHINE IST VOR DEM STARTEN MIT ÖL ZU FÜLLEN
WAARSCHUWING	DEZE MACHINE MOET VOOR HET STARTEN MET OLIE GEVULD WORDEN
CDC: 603 604 610 612 621 623 624	

1.8 Specific machine performance

For performance parameters see section 1.5, *Duty conditions*. Where performance data has been supplied separately to the purchaser these should be obtained and retained with these User Instructions if required.

1.9 Noise level

Attention must be given to the exposure of personnel to the noise, and local legislation will define when guidance to personnel on noise limitation is required, and when noise exposure reduction is mandatory. This is typically 80 to 85 dBA.

The usual approach is to control the exposure time to the noise or to enclose the machine to reduce emitted sound. You may have already specified a limiting noise level when the equipment was ordered, however if no noise requirements were defined, then attention is drawn to the following table to give an indication of equipment noise level so that you can take the appropriate action in your plant. Pump noise level is dependent on a number of operational factors, flow rate, pipework design and acoustic characteristics of the building, and so the

values given in the below table are subject to a 3 dBA tolerance and cannot be guaranteed.

Similarly the motor noise assumed in the “pump and motor” noise is that typically expected from standard and high efficiency motors when on load directly driving the pump. Note that a motor driven by an inverter may show an increased noise at some speeds.

If a pump unit only has been purchased for fitting with your own driver then the “pump only” noise levels in the table should be combined with the level for the driver obtained from the supplier. Consult Flowserve or a noise specialist if assistance is required in combining the values.

It is recommended that where exposure approaches the prescribed limit, then site noise measurements should be made.

The values are in sound pressure level L_{pA} at 1 m (3.3 ft) from the machine, for “free field conditions over a reflecting plane”.

For estimating sound power level L_{WA} (re 1 pW) then add 14 dBA to the sound pressure value.

Motor size and speed kW (hp)	Typical sound pressure level L_{pA} at 1 m reference 20 μ Pa, dBA							
	3 550 r/min		2 900 r/min		1 750 r/min		1 450 r/min	
	Pump only	Pump and motor	Pump only	Pump and motor	Pump only	Pump and motor	Pump only	Pump and motor
<0.55(<0.75)	72	72	64	65	62	64	62	64
0.75 (1)	72	72	64	66	62	64	62	64
1.1 (1.5)	74	74	66	67	64	64	62	63
1.5 (2)	74	74	66	71	64	64	62	63
2.2 (3)	75	76	68	72	65	66	63	64
3 (4)	75	76	70	73	65	66	63	64
4 (5)	75	76	71	73	65	66	63	64
5.5 (7.5)	76	77	72	75	66	67	64	65
7.5 (10)	76	77	72	75	66	67	64	65
11(15)	80	81	76	78	70	71	68	69
15 (20)	80	81	76	78	70	71	68	69
18.5 (25)	81	81	77	78	71	71	69	71
22 (30)	81	81	77	79	71	71	69	71
30 (40)	83	83	79	81	73	73	71	73
37 (50)	83	83	79	81	73	73	71	73
45 (60)	86	86	82	84	76	76	74	76
55 (75)	86	86	82	84	76	76	74	76

① The noise level of machines in this range will most likely be of values which require noise exposure control, but typical values are inappropriate.

Note: for 1 180 and 960 r/min reduce 1 450 r/min values by 2 dBA. For 880 and 720 r/min reduce 1 450 r/min values by 3 dBA.

2 TRANSPORT AND STORAGE

2.1 Consignment receipt and unpacking

Immediately after receipt of the equipment it must be checked against the delivery/shipping documents for its completeness and that there has been no damage in transportation. Any shortage and/or damage must be reported immediately to Flowserve and must be received in writing within one month of receipt of the equipment. Later claims cannot be accepted.

Check any crate, boxes or wrappings for any accessories or spare parts that may be packed separately with the equipment or attached to side walls of the box or equipment.

Each product has a unique serial number. Check that this number corresponds with that advised and always quote this number in correspondence as well as when ordering spare parts or further accessories.

2.2 Handling

Boxes, crates, pallets or cartons may be unloaded using fork lift vehicles or slings dependent on their size and construction.

2.3 Lifting

 A crane must be used for all pump sets in excess of 25 kg (55 lb). Fully trained personnel must carry out lifting, in accordance with local regulations.

Pumps with drivers over approximately 7.5 kW, are supplied with the pump packed as a separate item from the driver. These should be lifted separately into their installed position, using lifting points on the pump soleplate, and on the motor.

 **CAUTION** When lifting pumps with drivers fitted, the resulting center of gravity may be above the lifting points, and the method of slinging must prevent the machine tipping during the lift. Slings, ropes and other lifting gear must be positioned where they cannot slip and where a balanced lift is obtained.

For improved stability unbolt the driver and lift the driver and pump separately.

 **CAUTION** To avoid distortion, the pump unit should be lifted as shown.

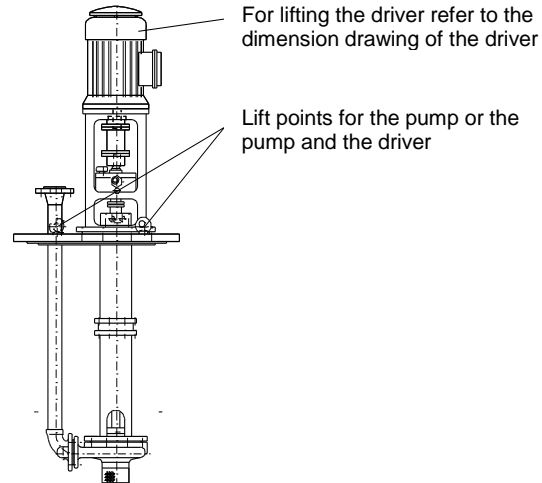

2.4 Storage

 **CAUTION** Store the pump in a clean, dry location away from vibration. Leave piping connection covers in place to keep dirt and other foreign material out of pump casing. Turn pump at intervals to prevent brinelling of the bearings and the seal faces, if fitted, from sticking.

The pump may be stored as above for up to 6 months. Consult Flowserve for preservative actions when a longer storage period is needed.

2.5 Recycling and end of product life

At the end of the service life of the product or its parts, the relevant materials and parts should be recycled or disposed of using an environmentally acceptable method and local requirements. If the product contains substances that are harmful to the environment, these should be removed and disposed of in accordance with current regulations. This also includes the liquids and/or gases that may be used in the "seal system" or other utilities.

 Make sure that hazardous substances are disposed of safely and that the correct personal protective equipment is used. The safety specifications must be in accordance with the current regulations at all times.

3 DESCRIPTION

3.1 Configurations

The pump is a modular designed cantilever centrifugal sump pump for medium duty chemical process liquid pumping requirements.

3.2 Name nomenclature

The pump size will be engraved on the nameplate typically as below:

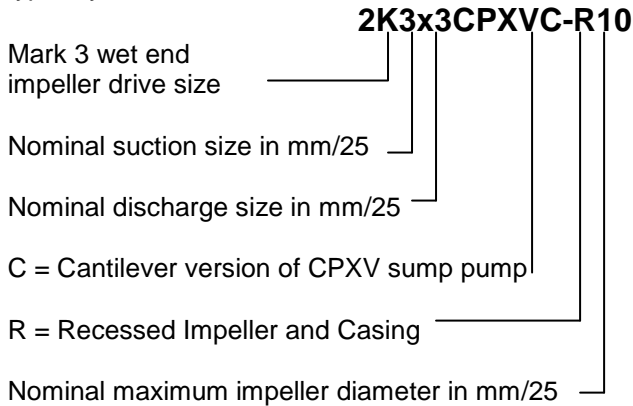

The typical nomenclature above is the general guide to the CPXVC size and configuration description.

For the 1.2 m nominal depth there are two sizes available at the maximum 4 pole 50 Hz and 60 Hz motor speeds, 2K2x2CPXVC-R10 and the 2K3x3CPXVC-R10 size. Identify the actual pump size and serial number from the pump nameplate. Check that this agrees with the applicable certification provided.

3.3 Design of major parts

3.3.1 Pump casing

The recess pump casing is designed for operation when submerged in the sump liquid.

3.3.2 Impeller

A recessed impeller is fitted which is recessed within the back of the casing and the impeller setting is to the rear backvanes.

3.3.3 Shaft

The shaft has a keyed drive coupling. It is supported by rolling bearing(s) above the soleplate and has no bearing(s) below the soleplate.

3.3.4 Bearing housing

The bearing housing enables adjustment of impeller rear face clearance via the bearing carrier jacking screws.

3.3.5 Pump bearings and lubrication

The pump is fitted with a thrust type ball bearing that may be configured differently dependent on use.

The thrust bearing(s) are grease lubricated.

3.3.6 Soleplate seal

The modular design enables one of a number of sealing options to be fitted.

3.3.7 Driver

The pump is normally driven by a flange mounted electric motor. An air or hydraulic motor may be utilized.

The position of the terminal box can be changed by rotating the complete motor. To do this, remove the fasteners from the motor flange, rotate the motor and re-fit the fasteners.

3.3.8 Accessories

Accessories may be fitted when specified by the customer.

3.4 Performance and operating limits

This product has been selected to meet the specifications of the purchase order. See section 1.5.

The following data is included as additional information to help with your installation. It is typical, and factors such as temperature, materials, and seal type may influence this data. If required, a definitive statement for your particular application can be obtained from Flowserve.

3.4.1 Operating limits

Maximum pump ambient temperature: +55 °C (131 °F) where driver is also rated for this ambient.

Maximum pump speed: refer to the nameplate.

4 INSTALLATION



Equipment operated in hazardous locations must comply with the relevant explosion protection regulations. See section 1.6.4, *Products used in potentially explosive atmospheres*.

4.1 Location

The pump should be located to allow room for access, ventilation, maintenance and inspection with ample headroom for lifting and should be as close as practicable to the supply of liquid to be pumped.

Refer to the general arrangement drawing for the pump set.

4.2 Part assemblies

On pump sets the coupling elements are supplied loose. It is the responsibility of the installer to ensure that the pump set is finally lined up and checked as detailed in section 4.5.4, *Final checks*.

4.3 Foundation



There are many methods of installing pump units to their foundations. The correct method depends on the size of the pump unit, its location and noise and vibration limitations. Non-compliance with the provision of correct foundation and installation may lead to failure of the pump and, as such, would be outside the terms of the warranty.

The pump mounting should have concrete or metal to support it around its edges.

4.3.1 Levelling

The soleplate must be level so that the pump column hangs vertically; confirmed by inspection. With the motor removed check the top face of the machined motor pedestal [3160] is set level to 0.05 mm (0.002 in.) or 0.2 mm/m (0.0025 in./ft) maximum.

Larger size motors are shipped unfitted. The motor will need to be fitted after completion of the pump foundation installation. Turn shaft clockwise by hand to ensure it is free to turn.

4.3.2 Packing pieces

Where the soleplate and its counterface do not each have a machined face, packing pieces (metallic shims) will need to be placed evenly adjacent to the foundation (holding down) bolts to avoid “soft-foot” distortion. Turn shaft clockwise by hand to ensure it is free to turn.

Soft-foot distortion may significantly increase vibration and damage equipment by causing distortion and should normally be inspected. If high vibration occurs when pump is run (see Section 5, *Commissioning, start-up, operation and shutdown*) place a vibration meter at the side of the motor as soft-foot is most effectively reduced when the vibration is reduced to a minimum. Overall vibration measurement can be used - it is not necessary to use a vibration spectrum to pick up soft-foot which occurs at 1x running speed and should be the first issue to check.

To adjust for soft-foot use a dial gauge on the soleplate top face near to the holding down bolt, zero it, record the soft-foot spring in the soleplate and undo one holding down bolt at a time.

Soft-foot is removed by inserting packing pieces (metallic shims) equal to or slightly less than the soft-foot spring amount recorded at the individual holding down point locations. Re-torque the holding down bolt. Continue this procedure for each holding down bolt position in turn, one at a time. The thickness of packing pieces (metallic shims) adjacent to an individual holding down bolt should not exceed 3 mm (0.12 in.); ie soft-foot spring is not to exceed 3 mm (0.12 in.) at any individual location.

4.4 Grouting

Where applicable, grout in the foundation bolts.

Grouting provides solid contact between the pump unit and foundation, prevents lateral movement of vibrating equipment and dampens resonant vibrations.

4.5 Piping



Protective covers are fitted to the pipe connections to prevent foreign bodies entering during transportation and installation. Ensure that these covers are removed from the pump before connecting any pipes.

Maximum forces and moments allowed on the pump flanges vary with the pump size and type. To minimize these forces and moments that may, if excessive, cause misalignment, hot bearings, worn couplings, vibration and the possible failure of the pump casing, the following points should be strictly followed:

- Prevent excessive external pipe load
- Never draw piping into place by applying force to pump flange connections
- Do not mount expansion joints so that their force, due to internal pressure, acts on the pump flange

4.5.1 Suction and discharge pipework

In order to minimize friction losses and hydraulic noise in the pipework it is good practice to choose pipework that is one or two sizes larger than the pump discharge. Typically main pipework velocities should not exceed 3 m/s (9 ft/sec) on the discharge.

CAUTION Never use the pump as a support for piping.

CAUTION Ensure piping and fittings are flushed before use.

Ensure piping for hazardous liquids is arranged to allow pump flushing before removal of the pump.

4.5.2 Discharge piping

A non-return valve should be located in the discharge pipework to protect the pump from excessive back pressure and hence reverse rotation when the unit is stopped.

Fitting an isolation valve will allow easier maintenance.

4.5.3 Maximum forces and moments allowed on the main soleplate discharge flange

The table below uses the sign convention shown for the pump soleplate discharge flange maximum forces and moments. These are valid for a pump end up to 100 °C (212 °F) and the soleplate on a rigid foundation.

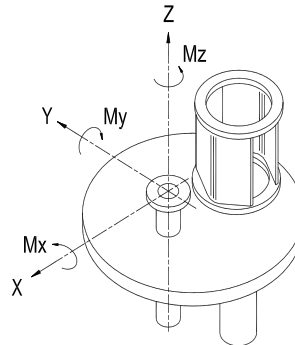

Discharge flange size mm (in.)	Maximum forces (F) in kN (lbf) and moments (M) in Nm (lbf-ft)							
	Fx	Fy	Fz	Fr	Mx	My	Mz	Mr
50 (2.0)	0.71 (160)	0.58 (130)	0.89 (200)	1.28 (290)	0.46 (340)	0.23 (170)	0.35 (260)	0.62 (460)
80 (3.0)	1.07 (240)	0.89 (200)	1.33 (300)	1.93 (430)	0.95 (700)	0.47 (350)	0.72 (530)	1.28 (950)
100 (4.0)	1.42 (320)	1.16 (260)	1.78 (400)	2.56 (570)	1.33 (980)	0.68 (500)	1.00 (740)	1.80 (1 330)

4.5.4 Auxiliary piping

4.5.4.1 Pumps fitted with a soleplate packed gland

CAUTION Ensure lubrication is supplied to the gland packing.

4.5.4.2 Pumps fitted with mechanical seals

Seal housings/covers having an auxiliary quench connection require connection to a suitable source of liquid flow, low pressure steam or static pressure from a header tank. Recommended pressure is 0.35 bar (5 psi) or less.

Double seals require a barrier liquid between the seals, compatible with the pumped liquid.

With back-to-back double seals, the barrier liquid should be at a minimum pressure of 1 bar (15 psi) above the maximum pressure on the pump side of the inner seal. The barrier liquid pressure must not exceed limitations of the seal on the atmospheric side. For toxic service the barrier liquid supply and discharge must be handled safely and in line with local legislation.

Special seals may require modification to auxiliary piping described above. Consult Flowserve if unsure of correct method or arrangement.

4.5.4.3 Pumps fitted with heating jacket

As the pump is constructed as a heated jacketed unit, steam must be connected to the steam inlet flange and removed via the steam outlet flange.

These flanges are located on the upper side of the soleplate. A flanged steam valve should be provided at the steam inlet and outlet for control of the steam supply.

4.5.5 Final checks

Check the tightness of all bolts in the suction and discharge pipework. Check also the tightness of all foundation bolts.

After connecting piping to the pump, rotate the shaft several times by hand to ensure there is no binding and all parts are free.

Recheck the flexible element coupling is aligned with the permitted limits.

Note: Where there is the option of an additional rigid coupling below the thrust bearing, above the mechanical seal, this has full metal to metal joints which does not permit its adjustment.

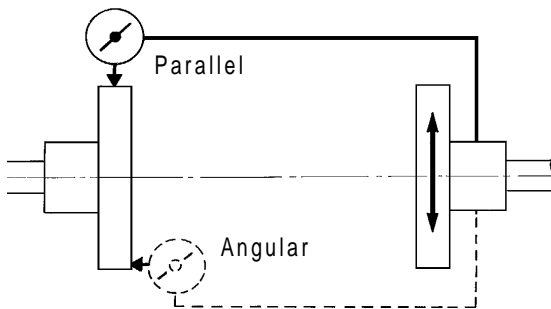

For couplings with narrow flanges use a dial indicator as shown. The alignment values are maximums for continuous service.

Permissible misalignment limits at working temperature:

- *Parallel alignment*
 - 0.25 mm (0.010 in.) TIR maximum
- *Angular alignment*
 - 0.3 mm (0.012 in.) TIR maximum for couplings not exceeding 100 mm (4 in.) flange diameter
 - 0.5 mm (0.020 in.) TIR maximum for couplings over 100 mm (4 in.) diameter
- Use the lower of the above values and values indicated in the coupling manual.

When checking parallel alignment, the total indicator read-out (TIR) shown is twice the value of the actual shaft displacement.

If alignment needs to be adjusted, a small amount of adjustment of the motor is available within the motor spigot but alignment is generally achieved automatically on assembly. Larger motors always require re-adjustment.

If it is not possible to achieve the alignment accuracy defined, it may be an indication that the pump has not been installed or handled correctly.

4.6 Electrical connections

DANGER Electrical connections must be made by a qualified Electrician in accordance with relevant local national and international regulations.

It is important to be aware of the EUROPEAN DIRECTIVE on potentially explosive areas where compliance with IEC60079-14 is an additional requirement for making electrical connections.

It is important to be aware of the EUROPEAN DIRECTIVE on electromagnetic compatibility when wiring up and installing equipment on site. Attention must be paid to ensure that the techniques used during wiring/installation do not increase electromagnetic emissions or decrease the electromagnetic immunity of the equipment, wiring or any connected devices. If in any doubt contact Flowserve for advice.

DANGER The motor must be wired up in accordance with the motor manufacturer's instructions (normally supplied within the terminal box) including any temperature, earth leakage, current and other protective devices as appropriate. The identification nameplate should be checked to ensure the power supply is appropriate.

A device to provide emergency stopping must be fitted. If not supplied pre-wired to the pump unit, the controller/starter electrical details will also be supplied within the controller/starter.

For electrical details on pump sets with controllers see the separate wiring diagram.

CAUTION See section 5.4, *Direction of rotation* before connecting the motor to the electrical supply.

4.7 Protection systems

The following protection systems are recommended particularly if the pump is installed in a potentially explosive area or is handling a hazardous liquid. If in any doubt consult Flowserve.

If there is any possibility of the system allowing the pump to run against a closed valve or below minimum continuous safe flow a protection device should be installed to ensure the temperature of the liquid does not rise to an unsafe level.

If there are any circumstances in which the system can allow the pump to run dry, or start up empty, a power monitor should, in addition to level control, be fitted to stop the pump or prevent it from being started. This is particularly relevant if the pump is handling a flammable liquid which would need an abatement technique due limitations of the ATEX Categories available.

If leakage of product from the pump or its associated sealing system can cause a hazard it is recommended that an appropriate leakage detection system is installed.

To prevent excessive surface temperatures at bearings it is recommended that temperature or vibration monitoring are carried out.

5 COMMISSIONING, START-UP, OPERATION AND SHUTDOWN

CAUTION *These operations must be carried out by fully qualified personnel.*

5.1 Pre-commissioning procedure

5.1.1 Lubrication

The pump grease lubricated antifriction bearings are normally supplied fitted with grease nipples and with pre-greased bearings.

Grease lubricated electric motor bearings are generally pre-greased. Refer to the motor UI for information on the motor lubrication schedule.

Pumps with grease lubricated thrust bearings and electric motors are supplied with pre-greased bearings.

Where the ambient is very low special lubricants are required. If in doubt consult Flowserve for recommendations of grease types at these lower temperatures. Where low ambient grease has been specially fitted this is Shell Aeroshell 22.

5.2 Pump lubricants

5.2.1 Recommended grease lubricants

Grease	NLGI 2 *	NLGI 3
Temp. range	-20 to +100 °C (-4 to +212 °F)	-20 to +100 °C (-4 to +212 °F)
Designation acc. to DIN	KP2K-25	KP3K-20
BP	Energrease LS-EP2	Energrease LS-EP3
Elf	Multis EP2	Multis EP3
Fuchs	RENOLIT EP2	RENOLIT EP3
Esso	Beacon EP2	Beacon EP3
Mobil	Mobilux EP2	Mobilux EP3 **
Q8	Rembrandt EP2	Rembrandt EP3
Shell	Alvania EP2	Alvania EP2
Texaco	Multifak EP2	Multifak EP3
SKF	LGEP 2	

* NLGI 2 is an alternative grease and is not to be mixed with other grades.

** Standard pre-packed grease for fitted antifriction bearings.

5.2.2 Bearing sizes and grease capacities

Bearing location	Size	Grease quantities – g (oz)
Drive end thrust bearing	3311C3 Z	35 (1.2)
Optional thrust bearing	7311 back-to-back pair	35 (1.2)
Pump end line bearing	6313C3 Z	20 (0.7)

Note: The bearing sizes do not constitute a purchasing specification.

5.2.3 Recommended grease lubricants

* NLGI 2 is an alternative grease and is not to be mixed with other grades.

** Standard pre-packed grease for fitted antifriction bearings.

5.2.4 Recommended fill quantities

Refer to section 5.2.2, *Bearing sizes and grease capacities*.

5.2.5 Lubrication schedule

5.2.5.1 Grease lubricated bearings

When grease nipples are fitted, one charge between grease changes is advisable for most operating conditions; ie 2 000 hours interval. Normal intervals between grease changes are 4 000 hours or at least every 6 months.

The characteristics of the installation and severity of service will determine the frequency of lubrication. Lubricant and bearing temperature analysis can be useful in optimizing lubricant change intervals.

The bearing temperature may be allowed to rise to 55 °C (99 °F) above ambient, but should not exceed 95 °C (204 °F). For most operating conditions, a quality grease having a lithium soap base and NLGI consistency of No 2 or No 3 is recommended. The drop point should exceed 175 °C (350 °F).

 Never mix greases containing different bases, thickeners or additives.

5.3 Recessed impeller clearance

The impeller clearance is set in the factory and only needs resetting after disassembly of the unit. For setting instructions see section 6.7, *Setting impeller clearance*.

5.4 Direction of rotation

 Serious damage can result if the pump is started or run in the wrong direction of rotation.

The pump is shipped with the coupling element removed. Ensure the direction of rotation of the motor is correct before fitting the coupling element. Direction of rotation must correspond to the direction arrow.

 If maintenance work has been carried out to the site's electricity supply, the direction of rotation should be re-checked as above in case the supply phasing has been altered.

5.5 Guarding

 Guarding is supplied fitted to the pump set.

In member countries of the EU and EFTA, it is a legal requirement that fasteners for guards must remain captive in the guard to comply with the Machinery Directive 2006/42/EC.

When releasing such guards, the fasteners must be unscrewed in an appropriate way to ensure that the fasteners remain captive.

Whenever guarding is removed or disturbed ensure that all the protective guards are securely refitted prior to start-up.

5.6 Priming and auxiliary supplies

5.6.1 Filling and priming

 The pump end needs to be completely submerged in the product.

5.6.2 Auxiliary supplies



 Ensure all electrical, hydraulic, pneumatic, sealant and lubrication systems (as applicable) are connected and operational.

5.6.3 Pumps fitted with a heating jacket

 The pump should be pre-heated for at least one hour using steam through the heating jacket before hot liquid is brought into the pump. The quantity, temperature and pressure can be obtained from the dimensional drawing. This action is important to avoid distortion and maintain the gap between impeller and casing.

Ensure pump is electrically isolated. Then before starting the driver rotate the shaft several times by (gloved) hand to ensure freedom of rotation as the high temperature will cause expansion and the increase in lengths of the components should be identical.

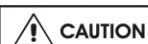
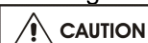
5.7 Starting the pump

- a)  Ensure flushing and/or cooling/heating liquid supplies are turned ON, before starting pump.
- b) CLOSE the outlet valve partially, but ensure that air is allowed to escape out of the discharge pipe.
- c)  Ensure that the liquid level in the sump is above the minimum pump casing submergence level.
- d)  Ensure all vent valves are closed before starting.
- e) Start motor and check the outlet pressure.
- f) If the pressure is satisfactory, SLOWLY open the outlet valve.
- g)  Do not run the pump with the outlet valve completely closed.
- h) If NO pressure, or LOW pressure, STOP the pump. Refer to section 7, *Faults; causes and remedies* for fault diagnosis.

5.8 Running the pump

5.8.1 Pumps fitted with packed gland

If the pump has a packed gland there must be some leakage from the gland. Gland nuts should initially be finger-tight only. Leakage should take place soon after the stuffing box is pressurised.



The gland must be adjusted evenly to give visible leakage and concentric alignment of the gland ring to avoid excess temperature. If no leakage takes place the packing will begin to overheat. If overheating takes place the pump should be stopped and allowed to cool before being re-started. When the pump is re-started, check to ensure leakage is taking place at the packed gland. If hot liquids are being pumped it may be necessary to slacken the gland nuts to achieve leakage.

Grease lubricated packed gland units will be fitted with packing greased on initial assembly. If no grease leakage takes place the packing will overheat.

The pump should be run for 30 minutes with steady leakage and the gland nuts tightened by 10 degrees at a time until leakage is reduced to an acceptable level. Bedding in of the packing may take another 30 minutes.



Care must be taken when adjusting the gland on an operating pump. Safety gloves are essential. Loose clothing must not be worn to avoid being caught up by the pump shaft. Shaft guards must be replaced after the gland adjustment is complete.



Never run gland packing dry, even for a short time.

5.8.2 Pumps fitted with mechanical seals

Mechanical seals require no adjustment. Any slight initial leakage will stop when the seal is run in.

Before pumping dirty liquids it is advisable, if possible, to run the pump in using clean liquid to safeguard the seal face.



External flush or quench should be started before the pump is run and allowed to flow for a period after the pump has stopped.

5.8.3 Bearings



If the pumps are working in a potentially explosive atmosphere temperature or vibration monitoring at the bearings is recommended.

If bearing temperatures are to be monitored it is essential that a benchmark temperature is recorded

at the commissioning stage and after the bearing temperature has stabilized.

- Record the bearing temperature (t) and the ambient temperature (ta)
- Estimate the likely maximum ambient temperature (tb)
- Set the alarm at (t+tb-ta+5) °C (t+tb-ta+10 °F) and the trip at 100 °C (212 °F) for oil lubrication and 105 °C (220 °F) for grease lubrication

It is important, particularly with grease lubrication, to keep a check on bearing temperatures. After start up the temperature rise should be gradual, reaching a maximum after approximately 1.5 to 2 hours. This temperature rise should then remain constant or marginally reduce with time. (Refer to section 5.2.5 for further information.)

5.8.4 Normal vibration levels, alarm and trip

For guidance, pumps generally fall under a classification for rigid support machines within the International rotating machinery standards and the recommended maximum levels below are based on those standards.



Alarm and trip values for installed pumps should be based on the actual measurements (N) taken on the pump in the fully commissioned as new condition.



Regular monitoring of the pump vibration is recommended to show any deterioration in pump or system operating conditions. The vibration is measured adjacent to the pump thrust bearing.

For remote installations continuous monitoring and automatic alert and shutdown is recommended.

Vibration velocity – unfiltered mm/sec (in./sec) r.m.s.		
Normal	N	≤ 7.1 (0.28)
Alarm	N x 1.25	≤ 9.0 (0.35)
Shutdown trip	N x 2.0	≤ 14.2 (0.56)



5.8.5 Stop/start frequency

Pump sets are normally suitable for the number of equally spaced stop/starts per hour shown in the table below. Check capability of the driver and control/starting system before commissioning.

Motor rating kW (hp)	Maximum stop/starts per hour
Up to 15 (20)	15
Between 15 (20) and 90 (120)	10

Where duty and standby pumps are installed it is recommended that they are run alternately every week.

5.9 Stopping and shutdown

- a)  Close the outlet valve, but ensure that the pump runs in this condition for no more than a few seconds.
- b) Stop the pump.
- c)  After stopping a jacketed pump, leave the steam supply on for approximately 20 minutes. Keep steam circulating in stand-by pumps.
- d) Switch off flushing and/or cooling/heating liquid supplies at a time appropriate to the process.
- e)  For prolonged shut-downs and especially when ambient temperatures are likely to drop below freezing point, the pump and any cooling and flushing arrangements must be drained or otherwise protected.

5.10 Hydraulic, mechanical and electrical duty

This product has been supplied to meet the performance specifications of your purchase order, however it is understood that during the life of the product these may change. The following notes may help the user decide how to evaluate the implications of any change. If in doubt contact your nearest Flowserve office.

5.10.1 Specific gravity (SG)

Pump capacity and total head in metres (feet) do not change with SG, however pressure displayed on a pressure gauge is directly proportional to SG. Power absorbed is also directly proportional to SG. It is therefore important to check that any change in SG will not overload the pump driver or over-pressurize the pump.

5.10.2 Viscosity

For a given flow rate the total head reduces with increased viscosity and increases with reduced viscosity. Also for a given flow rate the power absorbed increases with increased viscosity, and reduces with reduced viscosity. It is important that checks are made with your nearest Flowserve office if changes in viscosity are planned.

5.10.3 Pump speed

Changing pump speed effects flow, total head, power absorbed, $NPSH_R$, noise and vibration. Flow varies in direct proportion to pump speed, head varies as speed ratio squared and power varies as speed ratio cubed. The new duty, however, will also be dependent on the system curve. If increasing the speed, it is important therefore to ensure the

maximum pump working pressure and critical shaft speed are not exceeded, the driver is not overloaded, $NPSH_A > NPSH_R$, and that noise and vibration are within local requirements and regulations.

5.10.4 Net positive suction head ($NPSH_A$)

$NPSH_A$ available ($NPSH_A$) is a measure of the head available in the pumped liquid, above its vapor pressure, at the pump suction branch.

$NPSH_R$ required ($NPSH_R$) is a measure of the head required in the pumped liquid, above its vapor pressure, to prevent the pump from cavitating.

It is important that $NPSH_A > NPSH_R$. The margin between $NPSH_A > NPSH_R$ should be as large as possible.

If any change in $NPSH_A$ is proposed, ensure these margins are not significantly eroded. Refer to the pump performance curve to determine exact requirements particularly if flow has changed.

If in doubt please consult your nearest Flowserve office for advice and details of the minimum allowable margin for your application.

5.10.5 Pumped flow

Flow must not fall outside the minimum and maximum continuous safe flow shown on the pump performance curve and or data sheet.

6 MAINTENANCE

6.1 General

 It is the plant operator's responsibility to ensure that all maintenance, inspection and assembly work is carried out by authorized and qualified personnel who have adequately familiarized themselves with the subject matter by studying this manual in detail. (See also section 1.6.)

Any work on the machine must be performed when it is at a standstill. It is imperative that the procedure for shutting down the machine is followed, as described in section 5.9.

Guard fasteners must remain captive during dismantling of guards, as described in section 5.5.

On completion of work all guards and safety devices must be re-installed and made operative again.

Before restarting the machine, the relevant instructions listed in section 5, *Commissioning, start up, operation and shut down*, must be observed.

Oil and grease leaks may make the ground slippery. Machine maintenance must always begin and finish by cleaning the ground and the exterior of the machine.

If platforms, stairs and guard rails are required for maintenance, they must be placed for easy access to areas where maintenance and inspection are to be carried out. The positioning of these accessories must not limit access or hinder the lifting of the part to be serviced.

When air or compressed inert gas is used in the maintenance process, the operator and anyone in the vicinity must be careful and have the appropriate protection.

Do not spray air or compressed inert gas on skin.

Do not direct an air or gas jet towards other people.

Never use air or compressed inert gas to clean clothes.

Before working on the pump, take measures to prevent an uncontrolled start. Put a warning board on the starting device with the words: **"Machine under repair: do not start"**.

With electric drive equipment, lock the main switch open and withdraw any fuses. Put a warning board on the fuse box or main switch with the words: **"Machine under repair: do not connect"**.

Never clean equipment with inflammable solvents or carbon tetrachloride. Protect yourself against toxic fumes when using cleaning agents.

6.2 Maintenance schedule



It is recommended that a maintenance plan and schedule is adopted, in line with these User Instructions, to include the following:

- a) Any auxiliary systems installed must be monitored, if necessary, to ensure they function correctly.
- b) Gland packings must be adjusted correctly to give visible leakage and concentric alignment of the gland follower to prevent excessive temperature of the packing or follower.
- c) Check for any leaks from gaskets and seals. The correct functioning of the shaft seal must be checked regularly.

- d) Check bearing lubricant level, and if the hours run show a lubricant change is required.
- e) Check that the duty condition is in the safe operating range for the pump.
- f) Check vibration, noise level and surface temperature at the bearings to confirm satisfactory operation.
- g) Check dirt and dust is removed from areas around close clearances, bearing housings and motors.
- h) Check flexible coupling alignment and re-align if necessary.

Our specialist service personnel can help with preventative maintenance records and provide condition monitoring for temperature and vibration to identify the onset of potential problems.

If any problems are found the following sequence of actions should take place:

- a) Refer to section 7, *Faults; causes and remedies*, for fault diagnosis.
- b) Ensure equipment complies with the recommendations in this manual.
- c) Contact Flowserve if the problem persists.

6.2.1 Routine inspection (daily/weekly)



The following checks should be made and the appropriate action taken to remedy any deviations:

- a) Check operating behaviour. Ensure noise, vibration and bearing temperatures are normal.
- b) Check that there are no abnormal fluid or lubricant leaks (static and dynamic seals) and that any sealant systems (if fitted) are full and operating normally.
- c) Check that shaft seal leaks are within acceptable limits.
- d) Check the level and condition of oil lubricant. On grease lubricated pumps, check running hours since last recharge of grease or complete grease change.
- e) Check any auxiliary supplies eg heating/cooling (if fitted) are functioning correctly.
- f)  Refer to the manuals of any associated equipment for routine checks needed.

6.2.2 Periodic inspection (six monthly)

- a) Check foundation bolts for security of attachment and corrosion.
- b) Check pump running records for hourly usage to determine if bearing lubricant requires changing.
- c) The coupling should be checked for correct alignment and worn driving elements.
- d) Refer to the manuals of any associated equipment for periodic checks needed.

6.2.3 Re-lubrication

For general guidelines refer to section 5.2.5, *Lubrication schedule*.

Lubricant and bearing temperature analysis can be useful in optimizing lubricant change intervals.

6.2.4 Mechanical seals

When leakage becomes unacceptable the seal will need replacement.

6.2.5 Gland packing

The stuffing box is normally supplied with a lantern ring to enable it to be lubricated to the centre of the packing with the required Molykote 44 Medium or equivalent grease from a Stauffer or equivalent.

6.3 Spare parts

6.3.1 Ordering of spares

Flowserve keeps records of all pumps that have been supplied. When ordering spares the following information should be quoted.

- 1) Pump serial number.
- 2) Pump size.
- 3) Part name – taken from section 8.
- 4) Part number – taken from section 8.
- 5) Number of parts required.

The pump size and serial number are shown on the pump nameplate.

To ensure continued satisfactory operation, replacement parts to the original design specification should be obtained from Flowserve. Any change to the original design specification (modification or use of a non-standard part) will invalidate the pump's safety certification.

6.3.2 Storage of spares

Spares should be stored in a clean dry area away from vibration. Inspection and re-treatment of metallic surfaces (if necessary) with preservative is recommended at 6 monthly intervals.

6.4 Recommended spares

(For two years operation - as per VDMA 24296)

Part no.	Designation	Number of pumps (including stand-by)						
		2	3	4	5	6/7	8/9	10(+)
2100	Shaft	1		2			3	30%
2200	Impeller	1		2			3	30%
3011	Radial ball bearing	1		2		3	4	50%
3013	Bearing - thrust	1		2		3	4	50%
3712	Bearing nut	1		2		3	4	50%
4120	Lantern halves #	1		2			3	30%
4130	Gland packing - complete set #	2		3			4	40%
4200	Mechanical seals #	1		2		3		30%
4305	Lip seal #	4	6	8		9	10	100%
4590.1 *	Pump casing gasket	4	6	8		9	12	150%
4590.3	Discharge flange gasket	4	6	8		9	12	150%
4590.2	Impeller gasket	4	6	8		9	12	150%
4610.1	O-ring carrier		2			3	4	50%
4610.3	O-ring soleplate#		2			3	4	50%
-	Power end	-	-	-	-	-	1	2

When required due to fitting as part of the original build specification.

6.5 Tools required

A typical range of tools that will be required to maintain these pumps is listed below.

Readily available in standard tool kits, and dependent on pump size:

- Open ended spanners (wrenches) to suit up to M 48 screws/nuts
- Socket spanners (wrenches), up to M 48 screws
- Allen keys, up to 10 mm (A/F)
- Range of screwdrivers
- Soft mallet

More specialized equipment:

- Bearing pullers
- Bearing induction heater
- Dial test indicator
- C-spanner (wrench) - for removing shaft nut. (If difficulties in sourcing are encountered, consult Flowserve.)

6.6 Casing, seal housing and fastener torques

Fastener	Screw size	Torque Nm (lbf ft)
All except where otherwise stated	M8	16 (12)
	M10	25 (18)
	M12	35 (26)
	M16	80 (59)
	M20	130 (96)

6.7 Setting impeller clearance

This procedure may be required after the pump has been dismantled or a different clearance is required.

The impeller rear clearance is the setting. Set the back clearance to 1 mm (0.04 in.), as shown in the following illustration:

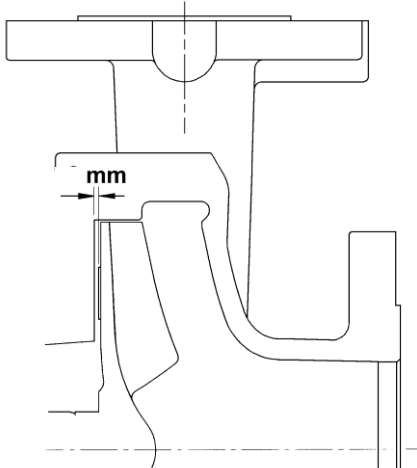

- a) Before carrying out this procedure ensure that any mechanical seal(s) fitted can tolerate a change in their axial setting, otherwise it will be necessary to dismantle the unit and reset the seal axial position after adjusting the impeller back clearance.

CAUTION *Some mechanical seal types may be impaired if moved more than 0.5 mm (0.02 in.) from their nominal setting.*

- b) Disconnect the coupling if it has limited axial flexibility.
- c) Record the gap between the bearing carrier [3240] and stool [3160] using feeler gauges.
- d) The impeller does not have a fine front clearance setting and adjustment of the impeller is not normally required
- e) Loosen the bearing carrier nuts and screws [6570.6] and back off the bearing carrier jacking screws by 1 mm (0.04 in).
- f) Tighten the bearing carrier screws [6570.5] evenly, pushing the bearing carrier away from the soleplate, until the impeller contacts the cover. Turn the shaft [2100], during this procedure, until a detectable rub is obtained. This is the zero clearance position.

Note: The shaft must be turned in the direction indicated on the casing and soleplate.

- g) Set a dial indicator to zero on the shaft end or measure the bearing carrier [3240] to stool [3160] gap and record the measurement.
- h) Slacken the bearing carrier [6570.5] screws evenly (about one flat at a time) until the dial

- i) indicator or feeler gauge shows the correct impeller clearance from the zero clearance position.
- j) Evenly tighten the bearing carrier screws [6570.6] keeping the dial indicator or feeler gauges reading the correct setting. Then tighten the hexagon nuts [6580.3] to lock the jacking screws in position.
- k) Compare the original and final gaps between the bearing carrier and soleplate to check if the movement of the shaft has exceeded the seal capability (over/under compression of the seal). Re-position the seal to correct this.
- l) Check that the shaft can turn freely without binding.
- m) If a cartridge seal is fitted, reset it at this point.
- n) Ensure the coupling distance between shaft ends (DBSE) is correct. Reset/re-align if necessary.

6.8 Renewal clearances

As wear takes place between the impeller and cover [1220] the overall efficiency of the pump set will decrease. To maintain optimum efficiency it is recommended that the clearance shown in section 6.7, *Setting impeller clearance*, is maintained.

6.9 Disassembly

CAUTION Refer to *Safety* section 1.6 before dismantling the pump.

CAUTION Before dismantling the pump for overhaul, ensure genuine Flowserve replacement parts are available.

Refer to sectional drawings for part numbers and identification. See section 8, *Parts lists and drawings*.

CAUTION For pumps with heating jackets, ensure that the pump is cooled down correctly and sufficiently before handling. After evacuating the tank and shutting off the pump, the pumped liquid flows down through the pump into the sump. After approximately 30 minutes the heating steam line should be closed.

6.9.1 Pump disassembly

- a) Disconnect all auxiliary pipes and tubes where applicable.
- b) Disconnect all discharge and auxiliary pipework.
- c) Remove coupling guard [7450], disconnect coupling [7000] and remove motor [8100].
- d) Remove nuts securing soleplate to foundations and lift the complete unit clear.
- e) Record the gap between bearing carrier [3240] and soleplate [6140] so that this setting can be used during workshop assembly.
- f) Remove suction tail pipe and/or strainer [9140 / 6531] if fitted.

- g) Remove all flushing lines as appropriate, casing screws and discharge flange bolts.
- h) Remove pump casing [1100].
- i) Remove pump casing [4590.1] and discharge flange [4590.3] gaskets and discard. (Replacement gaskets will be required for assembly.)
- j) Clean the gasket mating surfaces.

6.9.2 Impeller removal

 **NEVER APPLY HEAT TO REMOVE THE IMPELLER. TRAPPED WORKING LIQUID OR LUBRICANT MAY CAUSE AN EXPLOSION.**

6.9.2.1 Impeller removal with threaded on impeller

- a) Fit a chain wrench or bolt a bar to the holes in the coupling half, or fit a keyed shaft wrench directly to the shaft.
- b) Using gloved hands, raise the wrench above the workbench by turning the impeller [2200] clockwise as viewed from the impeller end of the shaft.
- c) Give the impeller a quick turn counter-clockwise to strike the wrench handle against the workbench or a wooden block. This will free the impeller from the shaft.
- d) The loosened impeller has an gasket [4610.2] that should be discarded. Use a new O-ring for assembly.

6.9.3 Cover and Support column

- a) Remove the nut [6580.1] which fixes the cover [1220] to the support column [1350].
- b) Remove the lower cover.
- c) Unbolt and remove support column [1350].

6.9.4 Bearings, seals and shaft

- a) Remove flingers [2540], wetted ones by their screw [6570]. If a seal is fitted in the soleplate, determine its type and remove the whole bearing housing, shaft and seal stool assembly complete ensuring sufficient support due to the weight of this large sub-assembly. To achieve this unscrew the seal stool to soleplate screws and any accessible seal to shaft clamp screws as appropriate. The seal stool can then be removed by unscrewing it from the bearing housing followed by the mechanical seal.
- b) Remove the bearing housing screws.
- c) Drive out the labyrinth disk [4330] from the soleplate (if fitted).

- d) Remove screws [6570.6] and pull the bearing carrier [3240] and upper shaft assembly out of the soleplate. Take care to support the long shaft to avoid bending or damage to it and any attached components.
- e) Pull off the coupling [7000] and remove the coupling key [6700.1].
- f) Remove thrust bearing circlip [6544](or bearing carrier locking ring if paired angular contact bearings are fitted).

Note:

Bearing carrier locking rings are left-hand thread.

- g) Slide the bearing carrier off of the bearing(s).
- h) Remove the bearing nut [3712].
- i) Pull off the bearing(s) [3013] and [3011].

6.10 Examination of parts

 **CAUTION** Used parts must be inspected before assembly to ensure the pump will subsequently run properly. In particular, fault diagnosis is essential to enhance pump and plant reliability.

6.10.1 Casing, cover and impeller

Inspect for excessive wear, pitting, corrosion, erosion or damage and any sealing surface irregularities. Replace as necessary.

6.10.2 Shaft

Obtain and fit a new shaft [2100] if grooved, pitted or worn.

6.10.3 Gaskets and O-rings

After dismantling, discard and replace.

6.10.4 Bearings

It is recommended that bearings [3013] and [3011] are not re-used after any removal from the shaft.

6.11 Assembly

To assemble the pump consult the sectional drawings. See section 8, *Parts lists and drawings*.

Ensure threads, gasket and O-ring mating faces are clean. Apply thread sealant to non-face sealing pipe thread fittings.

6.11.1 Mechanical seal or gland packing seal

(If there is no mechanical seal or gland packing at the soleplate, go to section 6.11.2, *Bearing housing sub-assembly*.)

Where a mechanical seal is used, extreme cleanliness is required during assembly. In many instances a pre-assembled cartridge seal will be used. Where this is not the case the sealing faces must be checked to be free from scratches or other damage. Use olive oil for fitting elastomers.

- a) Where an anti-rotation pin is fitted ensure that correct engagement with the slot is achieved.
- b) Carefully press stationary mechanical seal seat(s) into their housing such that these are not deformed or damaged.
- c) **Note:** Work to the specific manufacturer's instructions for the mechanical seal.

Where a packed stuffing box [4110] is fitted, pack the stuffing box cover before fitting on to the shaft as follows:

- a) Position each ring [4130] into the box individually, evenly and firmly.
- b) Check that the shaft sleeve [2400.2] freely rotates after fitting the first ring.
- c) Stagger the 45 degree scarf joints by 90 degrees from each other in the box.
- d) Insert the inner two packing rings.
- e) Insert lantern ring [4134] halves (if required).
- f) Insert the remaining packing rings.
- g) Position the gland [4120] squarely against the last ring, tighten the gland nuts finger-tight only and install on to bearing housing assembly.

Note: Jacketed sump pumps are fitted with a gland packing seal at the soleplate.

6.11.2 Bearing housing sub-assembly

- a) Clean the inside of the bearing carrier and bores for the bearings.
- b) Fill the grease retaining ring [3864] slot with the appropriate grease into bearing housing [3200]. The three thin grease rings may now be inserted into this internal slot.
- c) The radial bearing [3011] must be fitted to the shaft before inserting circlip [6544] over the shaft facing in the correct direction with taper face, facing the radial bearing. The optional pair of back to back thrust ball bearings use a nilos ring held by a retaining ring which must have the C spanner slots facing the impeller end. Only then can the thrust bearing [3013] be fitted to the shaft
(Note 1: If an optional pair of thrust bearings is to be fitted, these must be mounted back-to-back, as described below.)
- d) Press the thrust bearing(s) [3013] onto the shaft using equipment that can provide a steady, even load to the inner race.

- e) Use a spatula to fill sides of the bearing with grease of NLGI 3 grade.

- f) **Note:** On aggressive solvent/acid vapor service a special fluoro-silicone grease (Molykote FS3451) may be required. Pack the bearing fully by hand as no grease nipple is used in the design.
- g) Fit the self locking thrust bearing nut [3712] onto the shaft and tighten with a C spanner.
- h) Fit O-ring [4610.1] on the bearing carrier [3240] and lubricate the bearing carrier bore and O-ring with oil.
- i) Ensure the shaft coupling keyway edges are free of burrs. If optional proprietary labyrinth type bearing housing seals [4330] are used the O-rings should be oiled to assist assembly.
- j) Install the bearing carrier onto the shaft/bearing assembly and insert the circlip [6544] or if optional pair of back –to –back bearings, screw in the bearing carrier locking ring into the bearing carrier. Tighten up the bearing carrier locking ring using a C spanner.

Note: LH thread.

- k) Check shaft [2100] for free rotation.

6.11.3 Installing the shaft sub-assembly

- a) Prior to assembling the shaft and bearing carrier sub-assembly into the bearing housing [3200] install the bearing housing [3200], or if seal fitted both the bearing housing and seal stool tightened together, into the soleplate [6140] and fit using its fasteners [6570.2] and tighten these. Fit stool [3160] using its fasteners [6570.3], tighten these. The shaft assembly may now be fitted into the motor stool and bearing housing assembly until the gap between bearing carrier [3240] and bearing carrier [3200], is approximately 4 mm (0.16 in.).
- b) Install the bearing carrier hexagon screws [6570.6] and the hexagon screws [6570.5] and hexagon nuts [6580.3] but do not tighten.
- c) Press the flinger [2540.1] onto the shaft, where applicable. This should be set between 0.5 and 2 mm (0.02 and 0.08 in.) from the bearing carrier.
- d) Turn the shaft [2100] to check for freedom from rubbing.
- e) Fit the greasing fittings [3853] and grease relief [6569].
- f) Fit the upper and lower flingers [2540.2 and 2540.3] at least 6 mm (0.24 in.) from their bearing housing and cover respectively and tighten.
- g) Fit column pipe [1350] to the soleplate and tighten its fasteners [6580.2 and 6572.1].
- h) Fit the cover throttle bush [3300] and stud [6572.2] into the cover [1220].

- i) Fit cover [1220] and tighten the nut [6580.1] which fixes the cover to the support column [1350].
- j) Refit the coupling hub [7000].

6.11.4 Impeller and casing assembly

- a) Fit a new gasket [4590.2] into the impeller using a small amount of grease to hold it in place. Apply anti-galling compound (which does not contain copper) to the impeller thread to help subsequent removal.
- b) Assemble impeller [2200] onto the shaft [2100].
- c) Tighten the impeller. Use the same method as in disassembly but rotate in opposite direction. A few sharp strikes will tighten it to the correct level.
- d) Clean the casing spigot and gasket position mating surfaces.
- e) Fit a new casing gasket [4590.1].
- f) Install the pump casing with a new casing to discharge gasket [4590.3].
- g) Install casing hexagon screws [6570.1] to the specified torques.
- h) Check impeller rear clearance against original setting, or process requirement and adjust as

necessary. (See section 6.7, *Setting impeller clearance.*)

- i) Check freedom to rotate within pump casing..

6.11.5 Cartridge seal assembly (if fitted)

- a) To set, or reset, a cartridge seal having a PTFE setting ring-throttle and no separate setting clips, finger tighten the seal cover stud nuts, then fully torque up the sleeve screws.
- b) Torque up the seal cover stud nuts.

6.11.6 Coupling, motor and ancillaries

- a) Reconnect pump ancillary fittings and piping.
- b) Install pump into sump and connect up remaining fittings and piping.
- c) Re-check freedom of shaft to rotate by hand.
- d) Re-install motor (check for correct rotation) and then fit coupling drive element and guards.
- e) If all is correct continue with the procedure described under Section 4, *Installation* and section 5, *Commissioning, start-up, operation and shutdown.*

FAULT SYMPTOM

Pump overheats and seizes																																		
↓	Bearings have short life																																	
↓	Pump vibrates or is noisy																																	
↓	Mechanical seal has short life																																	
↓	Mechanical seal leaks excessively																																	
↓	Pump requires excessive power																																	
↓	Pump loses prime after starting																																	
↓	Insufficient pressure developed																																	
↓	Insufficient capacity delivered																																	
↓	Pump does not deliver liquid																																	
										<table border="1"> <thead> <tr> <th>PROBABLE CAUSES</th> <th>POSSIBLE REMEDIES</th> </tr> </thead> <tbody> <tr> <td>Incorrect type of mechanical seal for operating conditions.</td> <td>CONSULT FLOWSERVE.</td> </tr> <tr> <td>Shaft running off centre because of worn bearings or misalignment.</td> <td>Check misalignment and correct if necessary. If alignment satisfactory check bearings for excessive wear.</td> </tr> <tr> <td>Impeller out of balance resulting in vibration.</td> <td rowspan="3">Check and CONSULT FLOWSERVE.</td> </tr> <tr> <td>Abrasive solids in liquid pumped.</td> </tr> <tr> <td>Internal misalignment of parts preventing seal ring and seat from mating properly.</td> </tr> <tr> <td>Mechanical seal was run dry.</td> <td>Check mechanical seal condition and source of dry running and repair.</td> </tr> <tr> <td>Internal misalignment due to improper repairs causing impeller to rub.</td> <td>Check method of assembly, possible damage or state of cleanliness during assembly. Remedy or CONSULT FLOWSERVE, if necessary.</td> </tr> <tr> <td>Excessive thrust caused by a mechanical failure inside the pump.</td> <td>Check wear condition of impeller, its clearances and liquid passages.</td> </tr> <tr> <td>Excessive grease in ball bearings.</td> <td>Check method of regreasing.</td> </tr> <tr> <td>Lack of lubrication for bearings.</td> <td>Check hours run since last change of lubricant, the schedule and its basis.</td> </tr> <tr> <td>Improper installation of bearings (damage during assembly, incorrect assembly, wrong type of bearing etc).</td> <td>Check method of assembly, possible damage or state of cleanliness during assembly and type of bearing used. Remedy or CONSULT FLOWSERVE, if necessary.</td> </tr> <tr> <td>Damaged bearings due to contamination.</td> <td>Check contamination source and replace damaged bearings.</td> </tr> </tbody> </table>	PROBABLE CAUSES	POSSIBLE REMEDIES	Incorrect type of mechanical seal for operating conditions.	CONSULT FLOWSERVE.	Shaft running off centre because of worn bearings or misalignment.	Check misalignment and correct if necessary. If alignment satisfactory check bearings for excessive wear.	Impeller out of balance resulting in vibration.	Check and CONSULT FLOWSERVE.	Abrasive solids in liquid pumped.	Internal misalignment of parts preventing seal ring and seat from mating properly.	Mechanical seal was run dry.	Check mechanical seal condition and source of dry running and repair.	Internal misalignment due to improper repairs causing impeller to rub.	Check method of assembly, possible damage or state of cleanliness during assembly. Remedy or CONSULT FLOWSERVE, if necessary.	Excessive thrust caused by a mechanical failure inside the pump.	Check wear condition of impeller, its clearances and liquid passages.	Excessive grease in ball bearings.	Check method of regreasing.	Lack of lubrication for bearings.	Check hours run since last change of lubricant, the schedule and its basis.	Improper installation of bearings (damage during assembly, incorrect assembly, wrong type of bearing etc).	Check method of assembly, possible damage or state of cleanliness during assembly and type of bearing used. Remedy or CONSULT FLOWSERVE, if necessary.	Damaged bearings due to contamination.	Check contamination source and replace damaged bearings.
PROBABLE CAUSES	POSSIBLE REMEDIES																																	
Incorrect type of mechanical seal for operating conditions.	CONSULT FLOWSERVE.																																	
Shaft running off centre because of worn bearings or misalignment.	Check misalignment and correct if necessary. If alignment satisfactory check bearings for excessive wear.																																	
Impeller out of balance resulting in vibration.	Check and CONSULT FLOWSERVE.																																	
Abrasive solids in liquid pumped.																																		
Internal misalignment of parts preventing seal ring and seat from mating properly.																																		
Mechanical seal was run dry.	Check mechanical seal condition and source of dry running and repair.																																	
Internal misalignment due to improper repairs causing impeller to rub.	Check method of assembly, possible damage or state of cleanliness during assembly. Remedy or CONSULT FLOWSERVE, if necessary.																																	
Excessive thrust caused by a mechanical failure inside the pump.	Check wear condition of impeller, its clearances and liquid passages.																																	
Excessive grease in ball bearings.	Check method of regreasing.																																	
Lack of lubrication for bearings.	Check hours run since last change of lubricant, the schedule and its basis.																																	
Improper installation of bearings (damage during assembly, incorrect assembly, wrong type of bearing etc).	Check method of assembly, possible damage or state of cleanliness during assembly and type of bearing used. Remedy or CONSULT FLOWSERVE, if necessary.																																	
Damaged bearings due to contamination.	Check contamination source and replace damaged bearings.																																	
C. MOTOR ELECTRICAL PROBLEMS																																		
		●			●	●	●			Wrong direction of rotation.	Reverse 2 phases at motor terminal box.																							
				●			●			Motor running on 2 phases only.	Check supply and fuses.																							
	●	●							●	Motor running too slow.	Check motor terminal box connections and voltage.																							

8 PARTS LISTS AND DRAWINGS

8.1 CPXVC

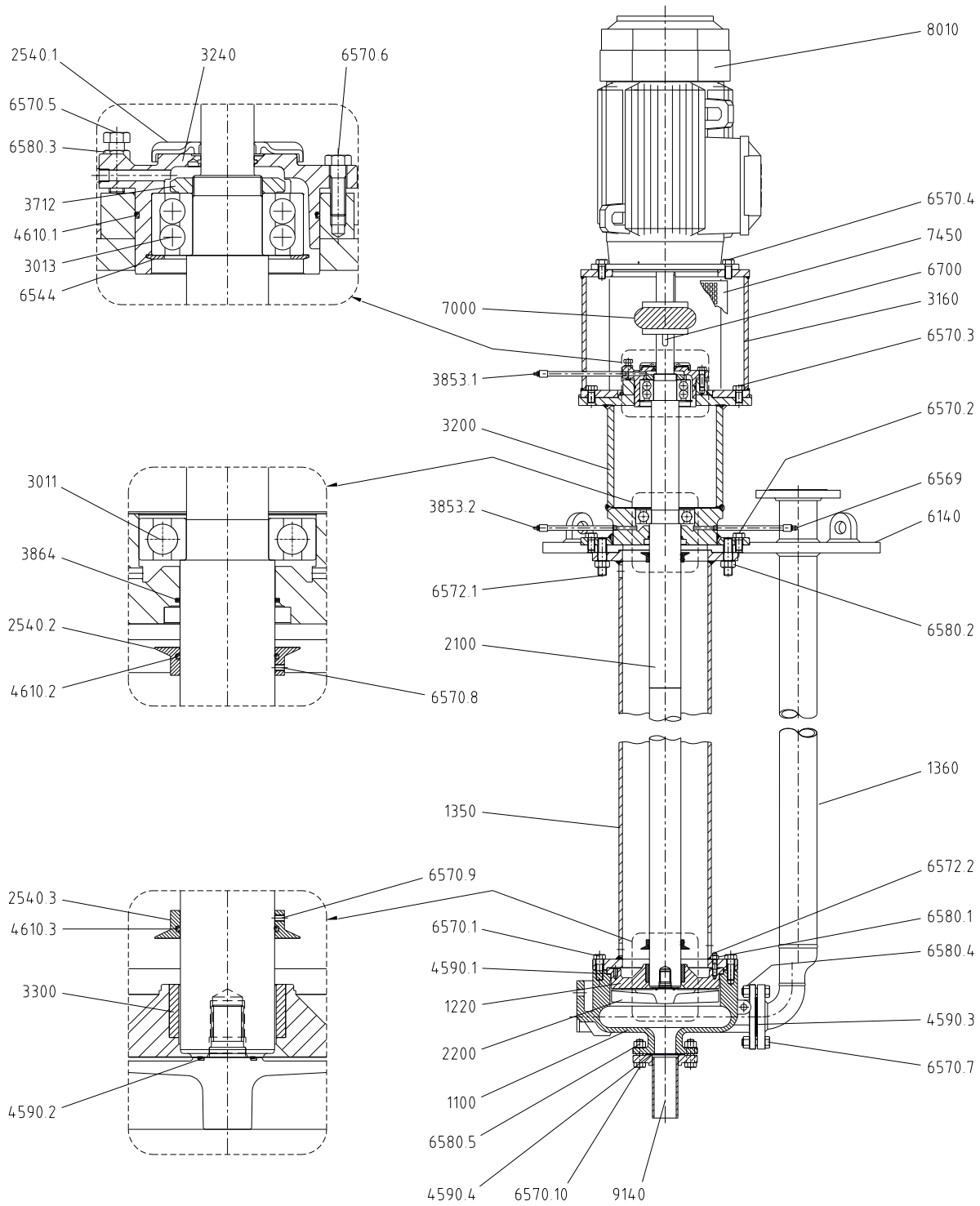

Drawing taken from 594419-005-2501

Item	Description
1100	Casing
1220	Cover
1350	Column pipe
1360	Discharge pipe
2100	Shaft
2200	Impeller
2540.1	Flinger
2540.2	Flinger
2540.3	Flinger
3011	Radial ball bearing
3013	Thrust ball bearing
3160	Motor pedestal
3200	Bearing housing
3240	Bearing carrier
3300	Cover bush
3712	Bearing lock nut
3853.1	Grease nipple
3853.2	Grease nipple
3864	Grease retainer
4590.1	Gasket
4590.2	Gasket
4590.3	Gasket
4590.4	Gasket
4610.1	O-ring
4610.2	O-ring
4610.3	O-ring
6140	Sole plate
6544	Circlip
6569	Plug
6570.1	Screw
6570.1	Screw
6570.2	Screw
6570.3	Screw
6570.4	Screw
6570.5	Screw
6570.6	Screw
6570.7	Screw
6570.8	Screw
6570.9	Screw
6572.1	Stud
6572.2	Stud
6580.1	Nut
6580.2	Nut
6580.3	Nut
6580.4	Nut
6580.5	Nut
6700	Key
7000	Coupling
7450	Guard
8010	Motor
9140	Tail pipe

Parts interchangeability

CPXV pump size	Bearing housing and carrier	Casing gasket
2K2x2CPXVC-R10	1	1
2K3x3CPXVC-R10	1	1

8.2 General arrangement drawing

The typical general arrangement drawing and any specific drawings required by the contract will be sent to the Purchaser separately unless the contract specifically calls for these to be included into the User Instructions. If required, copies of other drawings sent separately to the Purchaser should be obtained from the Purchaser and retained with these User Instructions.

9 CERTIFICATION

Certificates determined from the Contract requirements are provided with these Instructions where applicable. Examples are certificates for CE marking, ATEX marking etc. If required, copies of other certificates sent separately to the Purchaser should be obtained from the Purchaser for retention with these User Instructions.

10 OTHER RELEVANT DOCUMENTATION AND MANUALS

10.1 Supplementary User Instruction manuals

Supplementary instruction determined from the contract requirements for inclusion into User Instructions such as for a driver, instrumentation, controller, sub-driver, seals, sealant system, mounting component etc are included under this section. If further copies of these are required they should be obtained from the purchaser for retention with these User Instructions.

Where any pre-printed set of User Instructions are used, and satisfactory quality can be maintained only by avoiding copying these, they are included at the end of these User Instructions such as within a standard clear polymer software protection envelope.

10.2 Change notes

If any changes, agreed with Flowserve, are made to the product after its supply, a record of the details should be maintained with these User Instructions.

10.3 Additional sources of information

Reference 1:

NPSH for Rotordynamic Pumps: a reference guide, Europump Guide No. 1, Europump & World Pumps, Elsevier Science, United Kingdom, 1999.

Reference 2:

Pumping Manual, 9th edition, T.C. Dickenson, Elsevier Advanced Technology, United Kingdom, 1995.

Reference 3:

Pump Handbook, 2nd edition, Igor J. Karassik et al, McGraw-Hill Inc., New York, 1993.

Reference 4:

ANSI/HI 1.1-1.5. Centrifugal Pumps - Nomenclature, Definitions, Application and Operation.

Reference 5:

ANSI B31.3 - Process Piping.

NOTES:

Your Flowserve Factory contact:

Flowserve Sihi (Spain) S.L.
Vereda de los Zapateros C.P. 28223
Pozuelo de Alarcón Madrid
Spain

Flowserve Sihi (Spain) S.L.
Avenida de Madrid 67 C.P. 28500
Arganda del Rey Madrid
Spain

Telephone +34 (0)91 709 1310
Fax +34 (0)91 715 9700

Your local Flowserve representatives:

Flowserve India Controls Pvt. Ltd. – Pump Division
SF No. 136/3 & 137, Myleripalayam Road,
Myleripalayam Post,
Othakkalmandapam, Coimbatore 641032, India

Flowserve Fluid Motion and Control (Suzhou)
Co. Ltd.
No. 26, Lisheng Road,
Suzhou Industrial Park, Suzhou 215021,
Jiangsu Province, P.R. China

Flowserve GB Limited
Lowfield Works, Balderton
Newark, Notts NG24 3BU
United Kingdom
Telephone (24 hours) +44 1636 494 600
Repair & Service Fax +44 1636 494 833

To find your local Flowserve representative please
use the Sales Support Locator System found at
www.flowserve.com

**FLOWSERVE REGIONAL
SALES OFFICES:****USA and Canada**

Flowserve Corporation
5215 North O'Connor Blvd.,
Suite 2300
Irving, Texas 75039-5421, USA
Telephone +1 972 443 6500
Fax +1 972 443 6800

Europe, Middle East, Africa

Flowserve FSG – Italy
Worthing S.r.l.
Via Rossini 90/92
20033 Desio (Milan), Italy
Telephone +39 0362 6121
Fax +39 0362 628 882

Latin America and Caribbean

Flowserve Corporation
6840 Wynnwood Lane
Houston, Texas 77008, USA
Telephone +1 713 803 4434
Fax +1 713 803 4497

Asia Pacific

Flowserve Pte. Ltd
10 Tuas Loop
Singapore 637345
Telephone +65 6771 0600
Fax +65 6862 2329