



ERP ***Overhung, End-Suction Process Pump***

ISO 13709/API 610 (OH2)



Experience In Motion

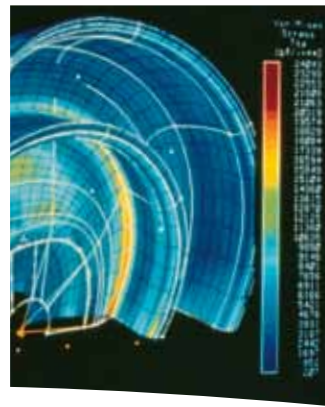

Pump Supplier to the World

Flowserve is the driving force in the global industrial pump marketplace. No other pump company in the world has the depth or breadth of expertise in the successful application of pre-engineered, engineered and special purpose pumps and systems.

Life Cycle Cost Solutions

Flowserve is providing pumping solutions which permit customers to reduce total life cycle costs and improve productivity, profitability and pumping system reliability.

Market Focused Customer Support

Product and industry specialists develop effective proposals and solutions directed toward market and customer preferences. They offer technical advice and assistance throughout each stage of the product life cycle, beginning with the inquiry.

Broad Product Lines

Flowserve offers a wide range of complementary pump types, from pre-engineered process pumps, to highly engineered and special purpose pumps and systems. Pumps are built to recognized global standards and customer specifications.

Pump designs include:

- Single stage process
- Between bearing single stage
- Between bearing multistage
- Vertical
- Submersible motor
- Rotary
- Reciprocating
- Nuclear
- Specialty

Product Brands of Distinction

ACEC™ Centrifugal Pumps

Aldrich™ Pumps

Byron Jackson® Pumps

Calder™ Energy Recovery Devices

Cameron™ Pumps

Durco® Process Pumps

Flowserve® Pumps

IDP® Pumps

Lawrence Pumps®

Niigata Worthington™ Pumps

Pacific® Pumps

Pleuger® Pumps

Scienco™ Pumps

Sier-Bath® Rotary Pumps

TKL™ Pumps

United Centrifugal® Pumps

Western Land Roller™ Irrigation Pumps

Wilson-Snyder® Pumps

Worthington® Pumps

Worthington Simpson™ Pumps

ERP
Overhung, End-Suction
Processing Pump
 ISO 13709/API 610 (OH2)



Complementary Pumps

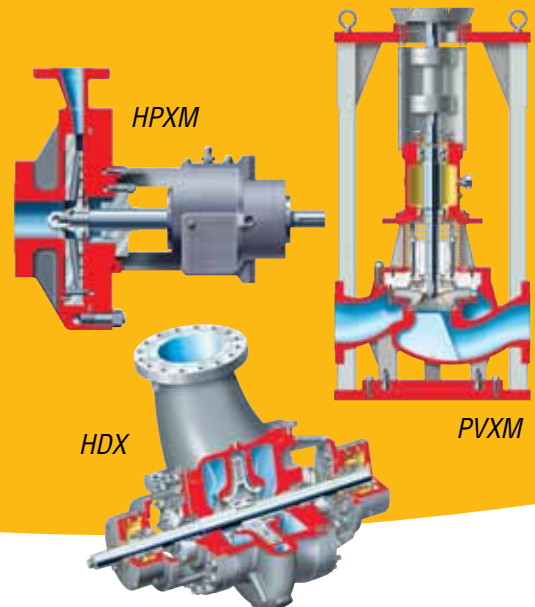

Maximum Mechanical and Hydraulic Design Flexibility

The ERP is the pump of choice for severe chemical, petrochemical, refining and heavy-duty industrial service where full compliance with API 610 is not required. This pump provides users with the important mechanical, hydraulic, emissions control and safety components required by ISO 13709/API 610 latest edition.

The ERP is an API type OH2, horizontal, end-suction, top discharge, centerline mounted pump. The ERP is available in all API 610 material combinations and can be equipped with special features for demanding services, including:

- High-suction pressure casing
- Inducer for low NPSH applications

Typical Applications

- Petroleum refining, production and distribution
- Petrochemical processing
- Heavy-duty chemical processing
- Gas industry services
- Boiler circulation
- Water services
- High-temperature applications
- General industrial

Complementary Pump Designs

The ERP may be used with other Flowserve models of API design. These include:

- Single- and two-stage, between bearings pumps
- Multistage, between bearings pumps
- Vertical, double-casing pumps
- Specialty pumps



ERP
Overhung, End-Suction
Process Pump
 ISO 13709/API 610 (OH2)

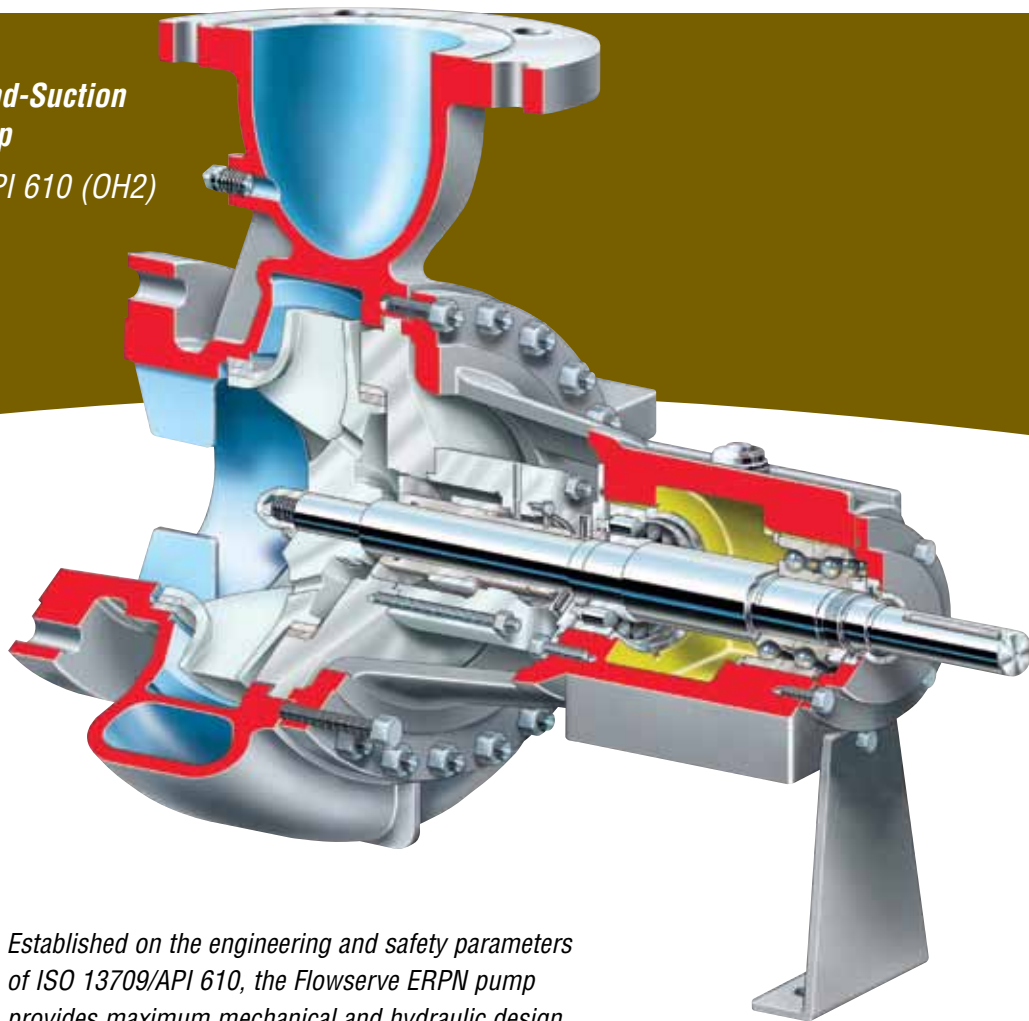

Established on the engineering and safety parameters of ISO 13709/API 610, the Flowserve ERP pump provides maximum mechanical and hydraulic design flexibility. With customization for individual applications, this pump is available in a variety of optional configurations, including:

- Closed impeller with front and back wear rings for standard services
- Inducer design for low NPSHA service requirements
- Semi-open impeller design with back vanes for liquids containing solids

Operating Parameters

- Rated flows to 1100 m³/h (4800 gpm)
- Heads to 230 m (755 ft)
- Temperatures to 350°C (660°F)
- Working pressures to 60 bar (870 psi)
- Suction pressures to 35 bar (500 psi)

Features and Benefits

Centerline Supported Pump Casing accommodates nozzle loads in accordance with ISO13709/API 610 design requirements, minimizing shaft misalignment and extending rotor, bearing and seal life

Precision Cast Impeller is dynamically balanced to limit vibration and assure smooth operation over a wide flow range. The impeller is positively secured by a set screw and a locknut, the threads of which are not exposed to the pumped liquid

Flanges are in accordance with ASME B16.5 Class 300 RF standard or 600 RF optional

Pump Casing and Cover feature metal-to-metal fit with fully confined, controlled compression gasket to ensure proper sealing and alignment. A double volute design is used on all large pump sizes

Suction Nozzle Guide Vane on larger sizes reduces inlet vortexing and ensures uniform flow into the impeller to achieve a reliable NPSH margin

Back Pull-Out Design simplifies maintenance as neither the motor nor the piping is disturbed

Renewable Casing and Impeller Wear Rings reduce maintenance costs and keep the clearance between wear surfaces in compliance with API 610 standards

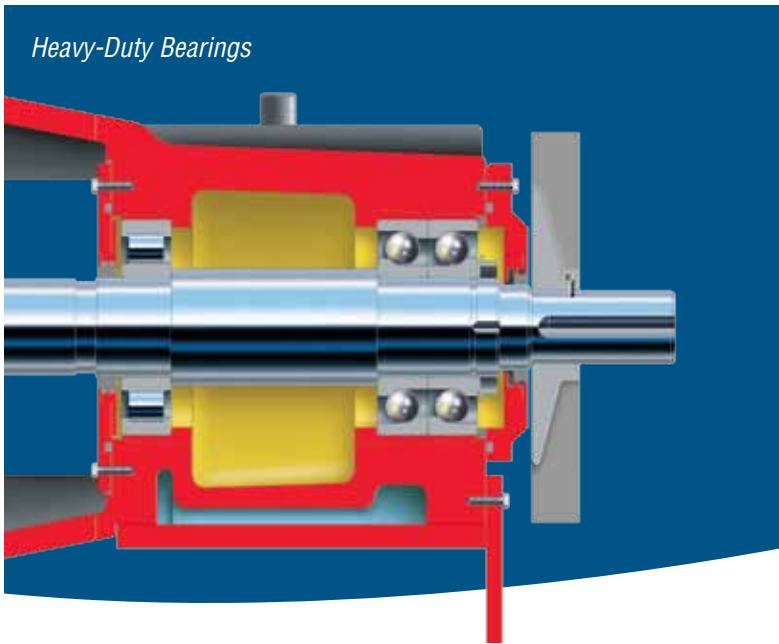
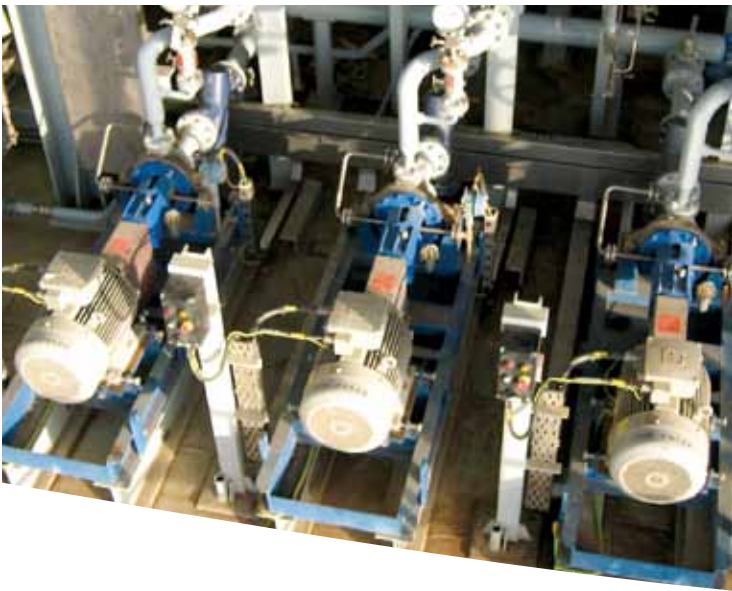

Heavy-Duty Bearing System

The bearing housing of the ERPN is made of heavy-duty carbon steel. Standard labyrinth type oil seals retain oil and exclude atmospheric contaminants and moisture. Optional bearing isolators are available.

As standard, the ERPN is equipped with roller type radial bearings and single row, 40° angular contact back-to-back mounted thrust bearings. High-suction pressure bearing arrangements are available.

Special Configurations

ERPN-O: Semi-Open Impeller

Incorporating a semi-open impeller and a replaceable front wear plate, the ERPN-O is recommended when pumping hydrocarbons containing solids.

ERPN-S: High-Suction Pressure Design

The ERPN-S incorporates a bearing arrangement able to support suction pressures up to 35 bar (500 psig) and an option for maximum working pressures to 60 bar (870 psig).

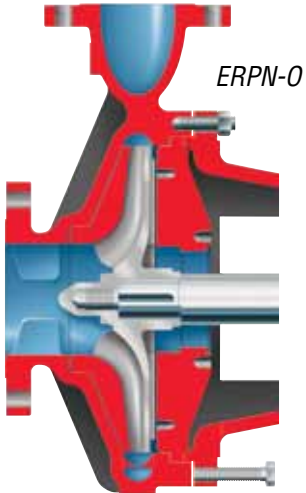

ISO 21049/API 682 Seal Chamber

The ERPN pump features an ISO 21049/API 682 compliant seal chamber which accommodates a wide variety of seal configurations including dual pressurized and unpressurized cartridge types for the most severe services.

Additionally, the ERPN is available with a full complement of API 610 seal flush piping plans.



Options and Technical Data

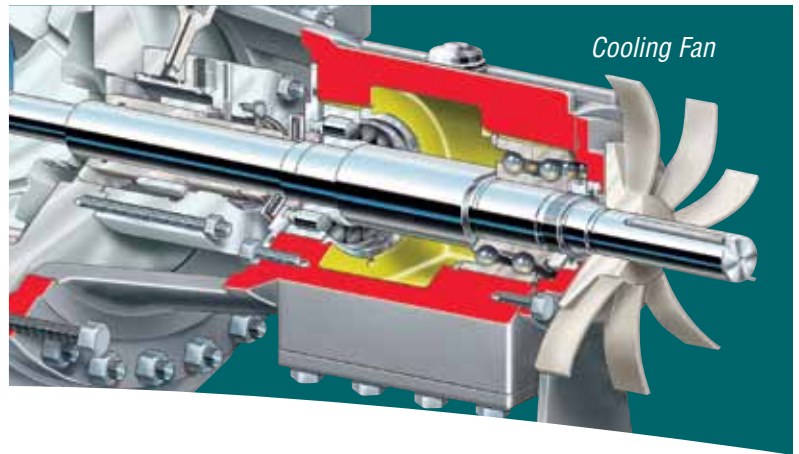
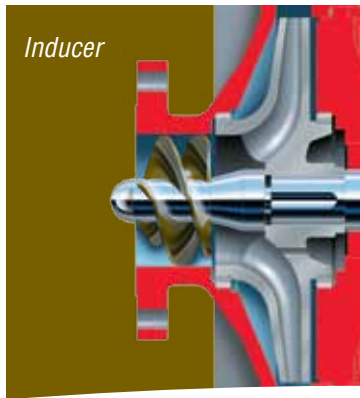

Optional Inducer

For applications with low NPSH, the ERPN can be fitted with an optional inducer (ERPN-IND). This high-suction specific speed, axial flow pumping device provides significant improvement in suction performance by reducing pump NPSHR.

API Material Combinations

The ERPN is available in all ISO 13709/API 610 materials combinations, including:

- **S-5:** Carbon steel with carbon steel internals
- **S-6:** Carbon steel with 12% chrome internals
- **S-8:** Carbon steel with 316 SS internals
- **C-6:** 12% chrome with 12% chrome internals
- **A-8:** 316 SS with 316 SS internals
- **D-1:** Duplex with duplex internals
- **D-2:** Super duplex with super duplex internals

The ERPN also is available in low-temperature carbon steel as well as NACE MR0175 and MR0103 compliant materials.

Bearing System Options

Numerous bearing system options are available with the ERPN pump:

- Oil mist and oil purge for continuous bearing lubrication
- Fan cooling for high operating or high ambient temperature applications
- Water cooled bearing housing for efficient water cooling

Available Baseplate Designs

- Drain pan design
 - Welded and fabricated carbon steel
 - Sloping drain pan with drain connection
- Drain rim design
 - Drain rim provided along baseplate perimeter
 - Drain pan provided below complete unit

ERPN Range Chart

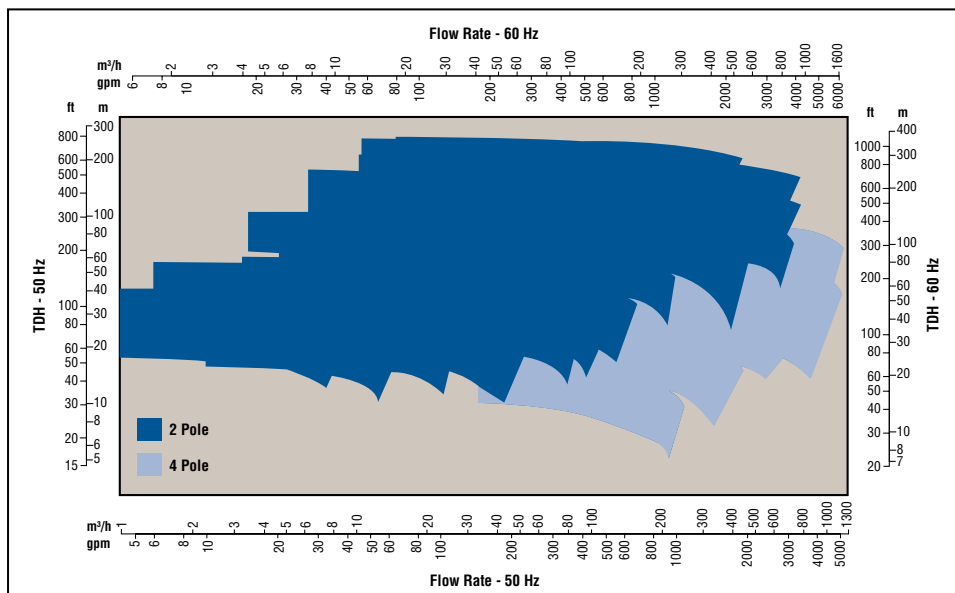

**Global Service
and Technical
Support**



Life Cycle Cost Solutions

Typically, 90% of the total life cycle cost (LCC) of a pumping system is accumulated after the equipment is purchased and installed. Flowserve has developed a comprehensive suite of solutions aimed at providing customers with unprecedented value and cost savings throughout the life span of the pumping system. These solutions account for every facet of life cycle cost, including:

Capital Expenses

- Initial purchase
- Installation

Operating Expenses

- Energy consumption
- Maintenance
- Production losses
- Environmental
- Inventory
- Operating
- Removal

Innovative Life Cycle Cost Solutions

- New Pump Selection
- Turnkey Engineering and Field Service
- Energy Management
- Pump Availability
- Proactive Maintenance
- Inventory Management

Typical Pump Life Cycle Costs¹

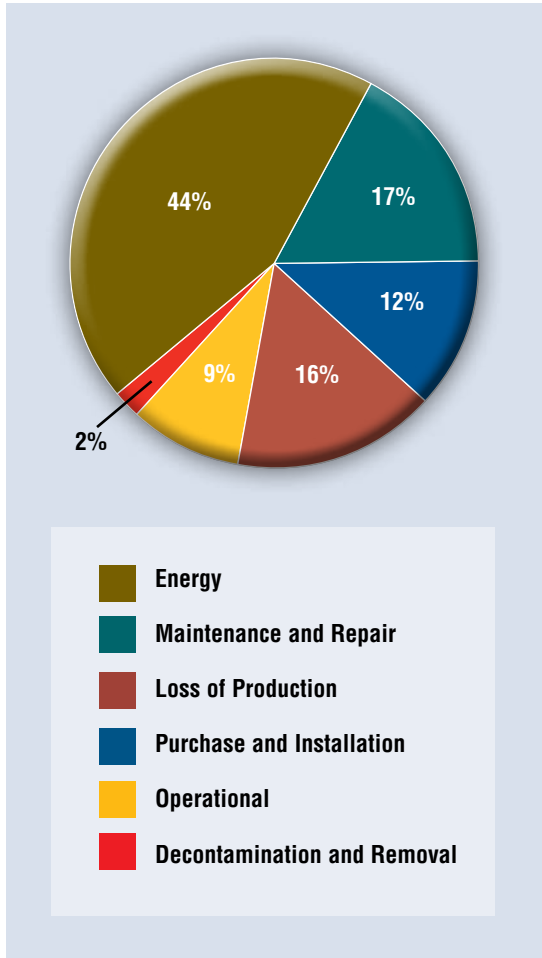

¹ While exact values may differ, these percentages are consistent with those published by leading pump manufacturers and end users, as well as industry associations and government agencies worldwide.

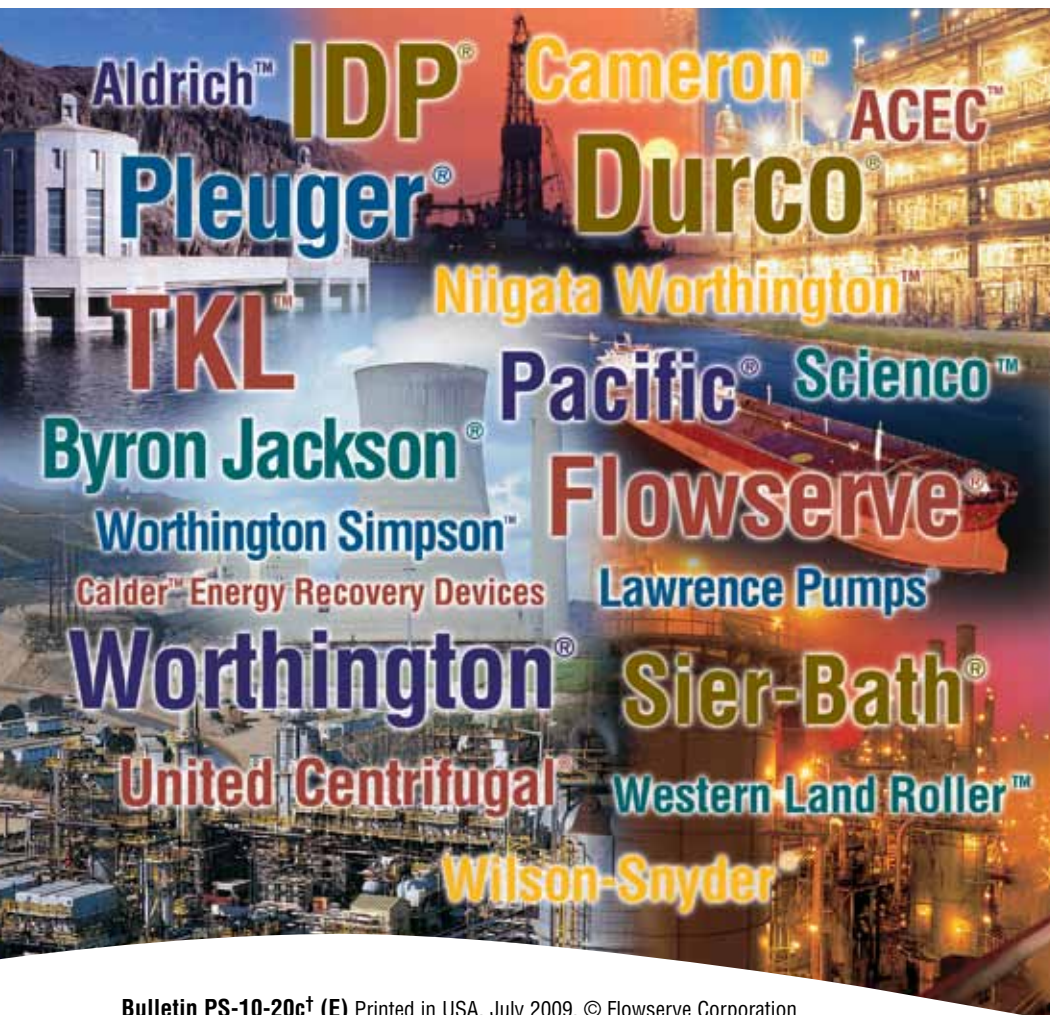

USA and Canada

Flowserve Corporation
5215 North O'Connor Blvd.
Suite 2300
Irving, Texas 75039-5421 USA
Telephone: 1 937 890 5839

Europe, Middle East, Africa

Flowserve Corporation
Gebouw Hagepoint
Westbroek 39-51
4822 ZX Breda
Netherlands
Telephone: 31 76 502 8920

Latin America

Flowserve Corporation
Boulevard del Cafetal
Edificio Ninina, Local 7
El Cafetal - Caracas
Venezuela 1061
Telephone: 58 212 985 3092
Telefax: 58 212 985 1007

Asia Pacific

Flowserve Pte. Ltd.
200 Pandan Loop #06-03/04
Pantech 21
Singapore 128388
Telephone: 65 6771 0600
Telefax: 65 6779 4607

Bulletin PS-10-20c† (E) Printed in USA. July 2009. © Flowserve Corporation

To find your local Flowserve representative:

For more information about Flowserve Corporation,
visit www.flowserve.com or call USA 1 800 728 PUMP (7867)