



## ***Dalian Quick Response Center***

Maintenance and Repair • On-Site Services  
Parts and Components • Pump Retrofits and Upgrades



***Experience In Motion***



## **Repair Service and Technical Support for Northeast China**

*The Flowserve Dalian Quick Response Center (QRC) focuses on providing customers with uncompromising service and support. The Dalian QRC is staffed by highly skilled engineers and technicians who are available around the clock, seven days a week to respond to customer queries, troubleshoot problems and provide reliable solutions. (24-hour service hotline: 158 4095 2621)*

### **Strength of Experience, Commitment to Excellence**

The Dalian QRC serves customers from industries requiring superior equipment performance and service life, such as:

- Oil and gas production
- Hydrocarbon processing
- Chemical processing
- Water resources
- Power generation
- Marine
- Mining and mineral processing
- Pulp and paper
- General industry
- Steel industry

### **Premier, Value-Added Service**

With unequaled pump knowledge, the Dalian QRC specializes in value-added repair services. QRC engineers and technicians service most types of equipment including pumps, agitators and seals. The dynamic range of services offered by the Dalian QRC include:

- Maintenance, repair and inspection service
- Pump upgrades, re-rates and retrofits
- Overhaul, outage and mechanical service
- Installation and commissioning service
- On-site repair and diagnostic services
- Contract maintenance
- Parts and components supply
- Field supervision
- Service maintenance contract







## Maintenance and Repair Services

### A Dynamic Range of Capabilities

The Dalian QRC facility features 1700 square meters (19 000 square feet) of shop and office space to support repair, engineering, sales and customer service functions. In-shop operations can handle a full range of pumps from small, single-stage overhung units to large multistage, between bearings pumps weighing in excess of 5 tons.



The Dalian QRC facility offers extensive machining services, including:

- Machining capabilities
  - 1.5m and 4m lathe
  - Vertical mills
  - EDM machine
  - Radial drills
  - Casing and mechanical seal lapping
- Finishing operations
  - Surface grinding
  - Sand blasting
- Assembly and fabrication
  - Certified welding to industry standards
  - Dynamic balancing (Schench 4M x 1.5T)
  - OPTALIGN® laser alignment
  - Heat treat ovens up to 1000°C (1832°F)
  - 50 tons hydraulic press
  - Hydraulic torque wrench
- Non-destructive examination (NDE)
- Quality control
  - Flat table
  - Hardness tester
  - Surface roughness tester
  - Seal testing

© OPTALIGN is a registered trademark of PRÜTECHNIK Dieter Busch AG.



## ***On-Site Services***

### ***Installation, Commissioning and Technical Services***

With limited staffing, customers often do not have the resources to supervise ongoing, equipment-related activities. As a result, field service experts from the Dalian QRC are available to support customer start-up requirements:

- Equipment removal and handling
- Equipment installation
- Maintenance activities
- Start-up and commissioning
- Equipment foundation inspection
- Pipe and pump bolt-up, alignment and inspection
- Energy saving and life cycle advantage program



### ***Overhaul, Outage and Mechanical Services***

The Dalian QRC has extensive experience and resources to provide integrated outage and mechanical services. Field service teams offer rapid mechanical assistance, including maintenance, upgrade and inspection services during times of high demand.





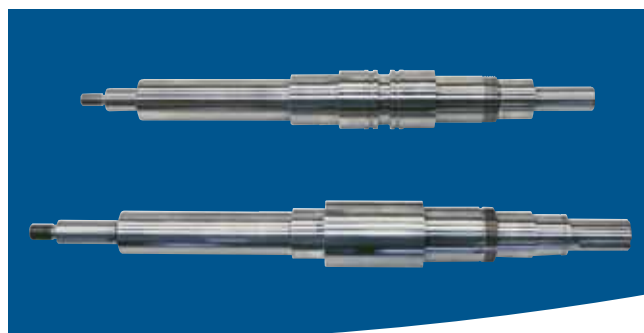

## Parts and Components

Quality parts in compliance with OEM specifications for the entire range of Flowserve product brands are readily available through the Dalian QRC. As all parts conform to original design and materials specifications, customers are ensured reliable operation and the lowest equipment ownership costs.

The Dalian QRC can also re-engineer and produce non-Flowserve components for equipment that is obsolete or when the original equipment manufacturer cannot be located.

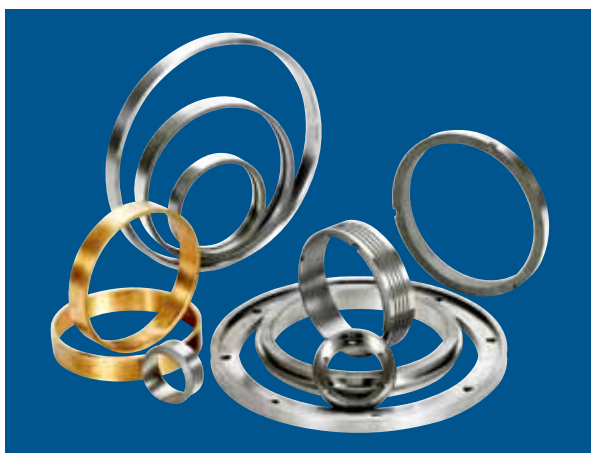

## The Flowserve Advantage

Flowserve manufactured parts offer significant benefits to customers. As an OEM, Flowserve understands the critical elements involved in designing and producing high quality parts. Whether cast or machined, Flowserve manufactured parts and components result in lower total operating costs and increased personnel safety.

- Flowserve casting quality is superior. Surface finishes, tolerances and material compositions are maintained within defined specifications.
- Flowserve parts incorporate the latest design changes which improve operating efficiency and extend equipment life.
- Customers benefit from ongoing research to develop new materials, overlay techniques and mechanically improved components.





*Take-off Nozzle Enlargement*



*Hydraulic Re-rate*

## Upgrades, Re-rates and Retrofits

Unreliable and leaking pumps can be refurbished to “as-new” condition via myriad mechanical upgrade and retrofit options. Expert engineers from the Dalian QRC facility have the experience to analyze and diagnose the root causes of mechanical pump failure and to recommend solutions that improve reliability, reduce emissions and increase plant uptime.

### Mechanical Upgrades and Retrofits

- ISO 13709/API 610 10th Edition upgrades, including the RVX and RHWX upgrades for horizontal and vertical overhung pumps, bring out-of-date process pumps to current API standards. This avoids costly new equipment investments.
- Other available mechanical upgrades include:
  - Increased rotor stiffness (Superstraight™ shaft material)
  - Bearing housing and bearings
  - Mechanical seal upgrade to API 682
  - Seal chamber
  - Coupling
  - Wear ring

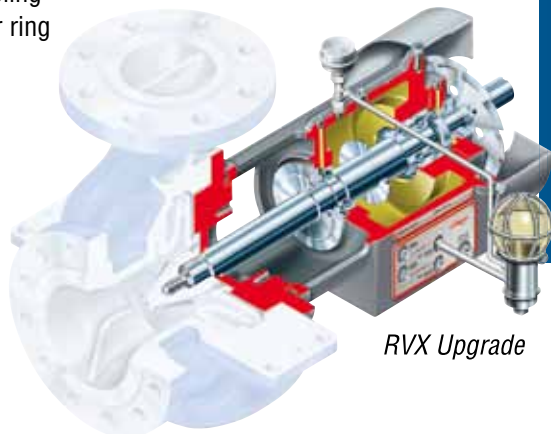

*RVX Upgrade*

### Hydraulic Upgrades and Retrofits

Hydraulic re-rates can be provided to cover changes in flow or TDH, or increase efficiency for power savings.

- Optimization of lip and shroud clearances (A/B/C gap)
- Impeller modifications
- High-efficiency rotors
- Low flow modifications
- Re-bowling
- De-staging or upstaging
- Optimized hydraulics to reduce erosion/abrasion

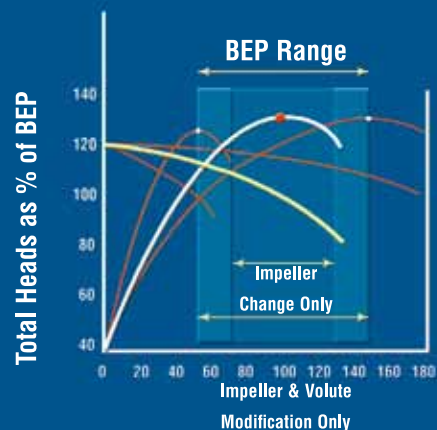

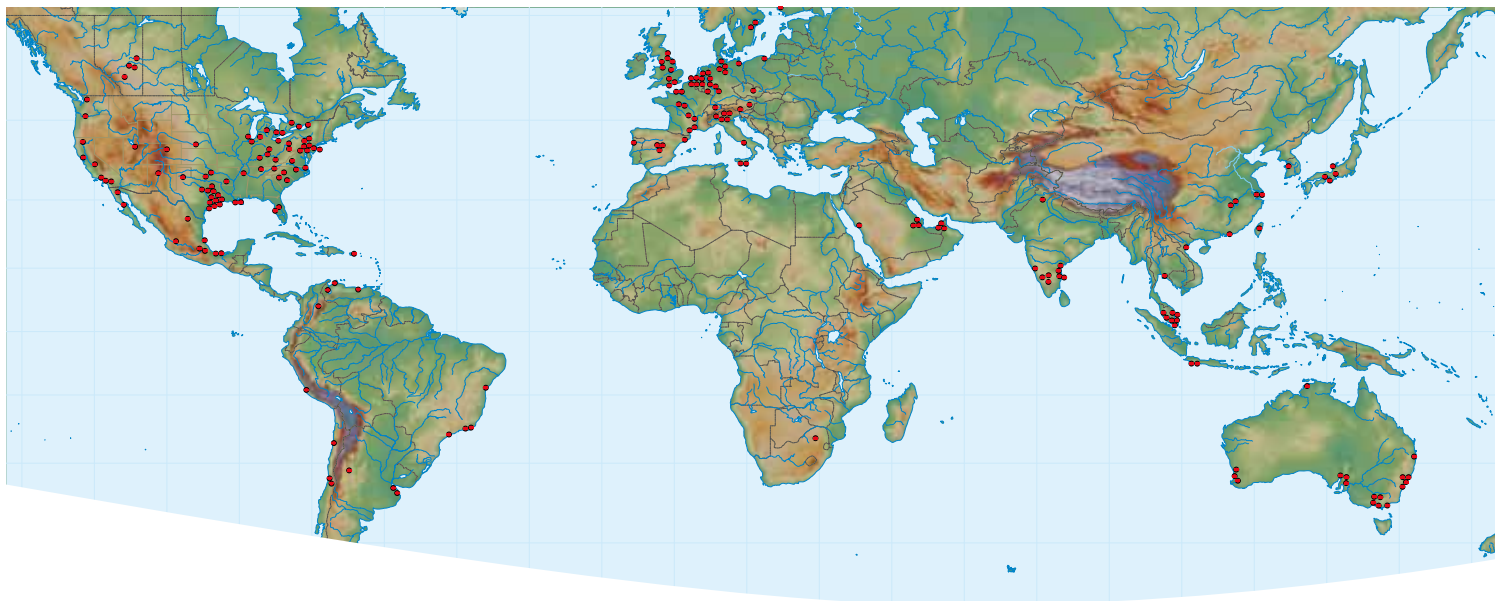

## Pump Supplier to the World

With an installed base of more than one million pumps, Flowserve Pumps has sales offices, service centers and manufacturing facilities all over the world. As a result of its extensive global footprint, Flowserve is ideally positioned to deliver best-in-class solutions to successfully address the world's most challenging projects.

### China Quick Response Centers

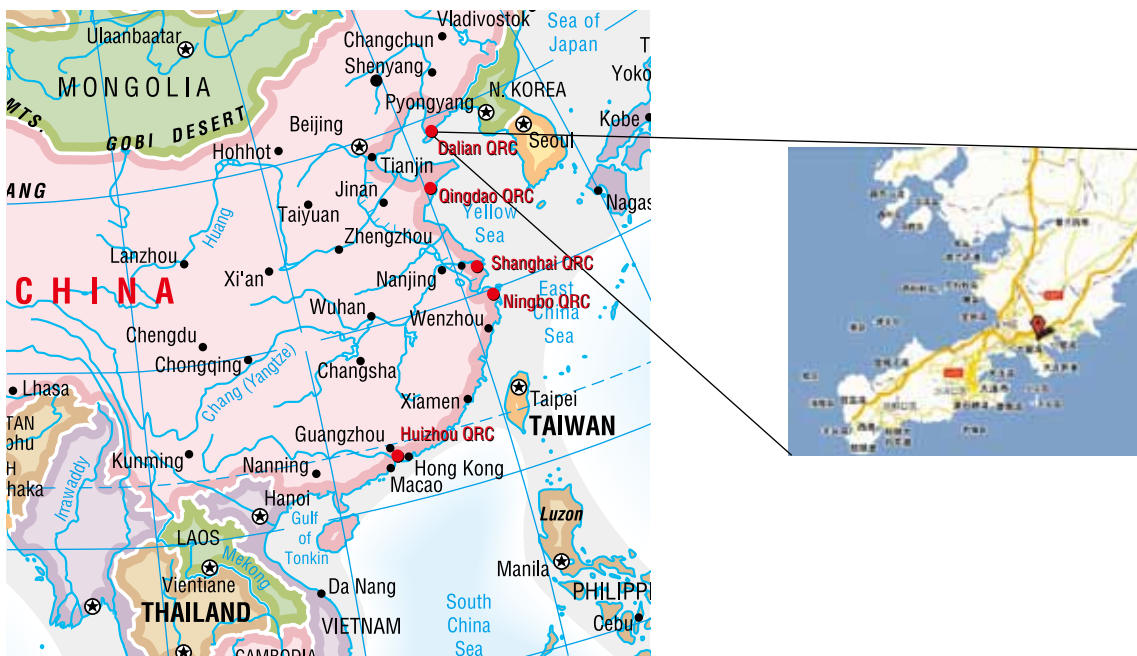





Bulletin FPD-1476 (E/A4) Printed in USA. August 2011. © Flowserve Corporation

**To find your local Flowserve representative:**

For more information about Flowserve Corporation, visit [www.flowserve.com](http://www.flowserve.com) or call +1 937 890 5839.

**Dalian**

No.5-2, Fenghui Int'l Ind. Park, No. B-3, Area B2, Dalian Free Trade Zone, Dalian, Liaoning Province, 116600, China  
Tel: (86 411) 3924 1919  
Fax: (86 411) 3924 1991

**Qingdao**

143 Zhuzhou Road, Laoshan District, Qingdao, Shandong Province, 266101, China  
Tel: (86 532) 6887 0200  
Fax: (86 532) 6887 0211

**Huizhou**

Zhangpu Industry Park, Zhangpu Village, West Shihua Avenue, Daya Bay, Danshui Town, Huizhou, 516211, China  
Tel: (86 752) 5280 100  
Fax: (86 752) 5280 300

**Shanghai**

Block 2, 255 Guiqiao Road, Jinqiao Development Zone (Jinqiao Science Park), Shanghai, 201206, China  
Tel: (86 21) 3865 4800  
Fax: (86 21) 5081 1781

**Ningbo**

75 Weisan Road, Xiaogang Town, Beilun District, Ningbo, Zhejiang Province, 315820, China  
Tel: (86 574) 8617 3876  
Fax: (86 574) 8617 3991

**Suzhou**

No.35 Baiyu Road, Industrial Park, Suzhou 215021, Jiangsu Province, 215021, China  
Tel: (86 512) 6288 8790  
Fax: (86 512) 6288 8737

**Beijing**

Unit A1/A2, 22F, Hanwei Plaza, No.7 Guanhua Road, Chaoyang District, Beijing, 100004, China  
Tel: (86 10) 5921 0600  
Fax: (86 10) 6561 1899