



Limitorque QX

Electronic Actuator

FCD LMENIM3314-01 - 06/18

Maintenance and Spare Parts



Contents

1	Introduction	7
1.1	Premise	7
1.2	Procedure Emphasis	7
1.3	Important Notes and Warning Statement	8
1.4	Reference Documents	8
1.5	This Document Applies to both QX – 90° Actuators and All QXM-Multi-Turn Actuators	8
2	QX Actuator Subassembly	9
2.1	QX Actuator Subassembly Components	10
2.1.1	Product Description	10
2.1.2	Storage	10
2.1.3	Unit Weights	11
2.2	Product Identification	11
2.2.1	Initial Inspection and Recording Suggestions	11
2.3	Maintenance	12
2.3.1	Recommended Maintenance	12
2.3.2	Unit Lubrication	12
2.3.3	O-Ring Lubrication	13
2.4	Subassembly Removal and Remounting Procedures	13
2.5	How to Order Replacement Subassemblies	13
2.5.1	Replacement Parts	13
2.5.2	Returning Procedure	14
2.5	Screw Preload (Torque)	14
3	Remove Actuator from Mounting Adapter	15
3.1	Actuator Removal with Type B4/B4E Base (Torque)	15
3.1.1	Removal (Type B4/B4E Base)	15
3.2	Actuator Removal with Type A1/A1E Base (Thrust)–QXM only	17
3.2.1	Optional Thrust Base Assembly QX-1 & 2	17
3.2.2	Optional Thrust Base Assembly Removal	17
3.2.3	Thrust Base Remounting	18
3.2.4	Removal (Type A1/A1E Base) Actuator Removal Separate from Thrust Base	19
3.2.5	Remounting (Type A1/A1E Base) Actuator Remounting Separate from Thrust Base	19
3.2.6	Removal (Type A1/A1E Base) Actuator and Thrust Base as a Unit	20
3.2.7	Remounting (Type A1/A1E Base) Actuator and Thrust Base as a Unit	20
4	Mechanical Assemblies	21
4.1	Motor Subassembly. QX-1 thru 5	21
4.1.1	Motor Subassembly Removal. QX-1 thru 5	22
4.1.2	Motor Subassembly Remounting. QX-1 thru 5	23
4.2	Handwheel Cover Subassembly, QX-1 thru 5	24
4.2.1	Handwheel Cover Subassembly Removal, QX-1 thru 5	24
4.2.2	Handwheel Cover Assembly Remounting	27
4.3	Motor Cartridge Subassembly, QX-1 thru 5	27
4.3.1	Motor Cartridge Subassembly Removal, QX-1 thru 5	27
4.3.2	Motor Cartridge Assembly Remounting	28
4.4	Gearing and Clutching	29
4.4.1	Gearing and Clutching Removal	31
4.4.2	Gearing and Clutching Remounting	33
4.5	Pipe Plug	35
4.6	Baseplate	35
4.6.1	Baseplate Removal	35
4.6.2	Baseplate Remounting	37
4.7	Worm Shaft Assembly	37

4.7.1 Worm Shaft Assembly Removal	38
4.7.2 Worm Shaft Assembly Replacement	38
4.8 Drive Sleeve, Stops and Encoder Shaft Assemblies	41
4.8.1 Drive Sleeve, Mechanical Stops, Encoder Shaft Removal	41
4.8.2 Drive Sleeve, Mechanical Stops and Encoder Shaft Assembly Remounting	42
4.9 Optional Baseplate Assembly, F/FA-05 & -07 QX-1 & 2, F/FA-10 QX-3 thru 5	43
4.9.1 Optional Baseplate Removal	43
4.9.2 Optional Baseplate Remounting	43
4.10 Torque Nut	44
4.10.1 Optional Small Baseplate Removal	45
4.10.2 Optional Small Baseplate Remounting	45
4.11 Optional Thrust Base Assembly QX-1 & 2	45
4.11.1 Optional Thrust Base Assembly Removal	46
4.11.2 Thrust Base Remounting	47
5 Encoder Assemblies	48
5.1 Encoder 90 Degree Unit Removal. QX-1 thru 5	48
5.1.1 90 Degree Encoder Removal	48
5.1.2 90 Degree Encoder Remounting	49
5.2 Multi Turn Encoder. QXM-1 thru 5, All RPMs	50
5.2.1 Multi Turn Encoder Removal	50
5.2.3 Multi Turn Encoder Remounting	52
6 Electronic Assemblies	54
6.1 Terminal Cover	54
6.1.1 Terminal Cover Removal	54
6.1.2 Terminal Cover Remounting	55
6.2 Controls Cover	55
6.2.1 Controls Cover Removal	56
6.2.2 Controls Cover Subassembly Remounting	57
6.3 Control Modules	58
6.3.1 Control Module Removal	58
6.3.2 Control Module Subassemblies	58
6.3.3 Control Module Remounting	61
6.4 Terminal Block	61
6.4.1 Terminal Block Shield	62
6.4.2 Terminal Block Removal	62
6.5 Mounting of Standard and Optional Controls	62
6.5.1 Installation	62
6.5.2 Removal	67
6.6 Optional Transformer	67
6.6.1 Optional Transformer Removal	68
6.6.2 Optional Transformer Remounting	69
7 Electronic Wiring (Cabling)	70
7.1 AC Low Voltage Wiring (cabling) Quick Reference Guide for Control Module and Main Board. (Less than 250 VAC)	70
7.1.1 AC Low Voltage Module (Version 1)	70
7.1.2 AC Low Voltage Module (Version 2)	71
7.1.3 DC Board Wiring (24 – 48 VDC)	71
7.2 High Voltage Wiring (cabling) Quick Reference Guide. (Greater than 250 VAC)	71
7.2.1 High Voltage Module	71
7.3 Optional Transformer Wiring (cabling) Quick Reference Guide	72
7.3.1 Optional Transformer Harness Wiring Used With Low Voltage Control Module	73
7.3.2 Optional Transformer Harness Wiring Used With High Voltage Control Module	73
7.3.3 Optional Transformer Harness Routing Used With High Voltage Control Module	73
7.4 Terminal Block Wiring Harness Numbers	74

8 Spares and Replacement Parts	75
8.1 Guidelines for Recommended Spare Parts	75
8.1.1 Wear Components	75
8.1.2 Bearings, O-rings, and Seals	75
8.1.3 Critical Components	75
8.2 Recommended Spare Parts for QX Actuators	76
8.2.1 Commissioning and Startup	76
8.2.2 Short-Term Duty	76
8.2.3 Long-Term Duty	76
8.2.4 Severe Duty	76
8.3 Other Concerns	77
9 Regulatory Information	78
9.1 Declaration of Conformity	78
9.2 Specific Conditions for Use — Atex/Cenelec/IECEx Applications	80
9.3 Statement of Compliance with Applicable European Directives	80

Figures

Figure 2.1 Typical QX Actuator	7
Figure 2.2 QX Nameplate	11
Figure 2.3 QX Nameplate	11
Figure 2.4 QX Oil fill /Plug Locations (QX-1 thru 5)	13
Figure 3.1 Torque Nut, F/FA-10, QX-1 & 2 and F/FA-12 and -14, QX-1 thru 5	15
Figure 3.2 Torque Nut, F/FA-05 and -07, QX-1 & 2 and F/FA-10, QX-1 thru 5	16
Figure 3.3 Optional Thrust Base Assembly	17
Figure 3.4 Optional Thrust Base Subassembly	18
Figure 4.1 Motor Cover and Motor Subassembly Removal	21
Figure 4.2 Motor Subassembly, Item 11	22
Figure 4.3 Motor Bracket Orientation View	23
Figure 4.4 Handwheel Cover Assembly	24
Figure 4.5 Handwheel Cover Subassembly, Item 10. QX-1 & 2	25
Figure 4.6 Handwheel Cover Subassembly, Item 10. QX-3 thru 5	26
Figure 4.7 Handwheel Subassembly, Item 10-4. QX-1 & 2 shown	26
Figure 4.8 Motor Cartridge Assembly Removal	27
Figure 4.9 Motor Cartridge Subassembly, Item 5	28
Figure 4.10 Gearing and clutching, QX-1 & 2	29
Figure 4.11 Gearing and clutching, QX-3 thru 5	30
Figure 4.12 Clutch Shaft Subassembly, Item 6. QX-1 & 2	32
Figure 4.13 Clutch Shaft Subassembly, Item 6. QX-3 thru 5	32
Figure 4.14 Clutch Shaft Subassembly, Item 7	33
Figure 4.15 Clutch Fork Shaft Remounting	34
Figure 4.16 Declutch Spring Assembly View. QX-1 & 2 shown	34
Figure 4.17 Pipe Plug	35
Figure 4.18 Baseplate, F/FA-10 QX-1 & 2, F/FA-12 & 14, QX-3 thru 5	36
Figure 4.19 F/FA-10 QX-1 & 2, F/FA-12 & 14, QX-3 thru 5 Baseplate Subassembly, Item 3	36
Figure 4.20 Worm Shaft	38
Figure 4.21 Drive Sleeve, Stops, and Encoder Shaft Assembly	40
Figure 4.22 Multi-turn Encoder Shaft Subassembly (Item 1-6)	41
Figure 4.23 Stop Groove View	42
Figure 4.24 F/FA-05 / 07, QX-1 & 2 or F/FA-10, QX-3 thru 5 Optional Baseplate	43
Figure 4.25 Torque nut, F/FA-10, QX-1 & 2 and F/FA-12 and -14, QX-1 thru 5	44
Figure 4.26 Torque nut, F/FA-05 and -07, QX-1 & 2 and F/FA-10, QX-1 thru 5	44
Figure 4.27 Optional Thrust Base Assembly QXM Only	45

Figure 4.28 Optional Thrust Base Subassembly	46
Figure 5.1 90° Encoder Assembly	48
Figure 5.2 Encoder To Subassembly, Item 14-1	49
Figure 5.3 Encoder To Unit Assembly View	49
Figure 5.4 Multi-turn Encoder Assembly	50
Figure 5.5 6.5-Turn Spur Gear Subassembly (Item 17-2)	51
Figure 5.6 20-Turn Spur Gear Subassembly (Item 17-2)	52
Figure 5.7 20-Turn Gear Slot Orientation View	52
Figure 6.1 Terminal Cover Assembly	54
Figure 6.2 Terminal Cover Subassembly	55
Figure 6.3 Controls Cover Assembly	56
Figure 6.4 Controls Cover Subassembly	57
Figure 6.5 Control Module Assembly	58
Figure 6.6 Low Voltage (Less than 250 VAC) Control Module Subassembly	59
Figure 6.7 High Voltage (Greater than 250 VAC) Control Module Subassembly	59
Figure 6.8 DCV Control Module Subassembly	60
Figure 6.9 Bracket Connector Retainer Assembly	61
Figure 6.10 Terminal Block Assembly	62
Figure 6.11 Terminal Block Shield	62
Figure 6.12 Quik Power Without Option Boards	64
Figure 6.13 Quik Power With Option Boards	65
Figure 6.14 Option Board Assembly	66
Figure 6.15 Optional Transformer Assembly	67
Figure 6.16 Optional Transformer Subassembly	68
Figure 7.1 Low Voltage QX Unit Wiring Connections	70
Figure 7.2 Low Voltage QX Unit Wiring Connections (Version 2)	71
Figure 7.3 DC QX Unit Wiring Connections	71
Figure 7.4 High Voltage QX Unit Wiring	72
Figure 7.5 Typical Toroid Transformer Label	72
Figure 7.6 Optional Low Voltage Transformer Harness Wiring	73
Figure 7.7 Optional High Voltage Transformer Harness Wiring	73
Figure 7.8 High Voltage Optional Transformer Harness Assembly Routing	73
Figure 7.9 Optional Transformer Harness Connector to Wire Position per Supply Voltage	74
Figure 7.10 Terminal Block Wiring Harness And Connector Numbers	74

Tables

Table 2.1 Typical QX Actuator Subassembly	10
Table 2.2 QX Unit Weights	11
Table 2.3 QX-1 thru 5 Oil Capacities	12
Table 2.4 Screw Preload Torque	14
Table 3.1 Torque Nut, F/FA-05 and -07, QX-1 & 2 and F/FA-10, QX-1 thru 5	16
Table 3.2 Optional Thrust Base Assembly	17
Table 3.3 Optional Thrust Base Subassembly	18
Table 4.1 Motor Parts List	21
Table 4.2 Motor Subassembly, Item 11	22
Table 4.3 Handwheel Cover Assembly	24
Table 4.4 Handwheel Cover Subassembly Item 10. QX -1 & 2	25
Table 4.5 Handwheel Cover Subassembly, Item 10. QX-3 thru 5	25
Table 4.6 Handwheel Subassembly, Item 10-4	26
Table 4.7 Motor Cartridge Assembly Removal	271
Table 4.8 Motor Cartridge Subassembly, Item 5	28
Table 4.9 Gearing and Clutching, QX-1 & 2	29

Table 4.10 Gearing and Clutching, QX-3 thru 5	30
Table 4.11 Clutch Shaft Subassembly, Item 6. QX-1 & 2	31
Table 4.12 Clutch Shaft Subassembly Item 6. QX-3 Thru 5	32
Table 4.13 Clutch Shaft Subassembly Item 7	33
Table 4.14 Pipe Plug	35
Table 4.15 Baseplate F/FA-10 QX-1 & 2, F/FA-12 & 14 QX-3 thru 5	36
Table 4.16 Baseplate Subassembly Item 3	36
Table 4.17 Worm Shaft Parts List	37
Table 4.18 Drive Sleeve, Stops, and Encoder Shaft Assembly	40
Table 4.19 Multi-turn Encoder Shaft Subassembly (Item 1-6)	41
Table 4.20 Optional Baseplate Removal	43
Table 4.21 Torque nut, F/FA-10, QX-1 & 2 and F/FA-12 and -14, QX-1 thru 5	44
Table 4.22 Torque nut F/FA-05 and -07 QX-1 & 2 and F/FA-10, QX-1 thru 5	44
Table 4.23 Optional Thrust Base Assembly	45
Table 4.24 Optional Thrust Base Subassembly	46
Table 5.1 90° Encoder Assembly	48
Table 5.2 Encoder Subassembly, Item 14-1	49
Table 5.3 Multi-Turn Encoder Assembly	50
Table 5.4 6.5-Turn Spur Gear Subassembly (Item 17-2)	51
Table 5.5 20-Turn Spur Gear Subassembly (Item 17-2)	51
Table 6.1 Terminal Cover Assembly	54
Table 6.2 Terminal Cover Subassembly	55
Table 6.3 Controls Cover Assembly	55
Table 6.4 Controls Cover Subassembly	56
Table 6.5 Control Module Assembly	57
Table 6.6 Low Voltage (Less than 250 VAC) Control Module Subassembly	58
Table 6.7 High Voltage (Greater than 250 VAC) Control Module Subassembly	59
Table 6.8 DCV Control Module Subassembly	60
Table 6.9 Terminal Block Assembly	61
Table 6.10 Control Board Connectors	66
Table 6.11 Screw Part Numbers	67
Table 6.12 Optional Transformer Assembly	67
Table 6.13 Optional Transformer Subassembly	68
Table 7.1 Connector to Wire Position per Supply Voltage	74

1 Introduction

1.1 Premise

The Flowserve Limitorque QX actuator components are separated into subassembly groupings. This manual covers the removal and remounting procedures for each subassembly group. Use these instructions when disassembly is required for service, maintenance or parts replacement.

1.2 Procedure Emphasis

Please refer to the following methods used to emphasize text throughout this manual. Safety Warnings, Cautions and Notes present material that is important to user safety. Be sure to read any safety notices you see as they could prevent equipment damage, personal injury or even death to you or a co-worker.

Safety notices are presented in this manual in three forms:

☠ **WARNING:** Refers to personal safety. Alerts the user to potential danger. Failure to follow warning notices could result in personal injury or death.

⚠ **CAUTION:** Directs the user's attention to general precautions that, if not followed, could result in personal injury and/or equipment damage.

NOTE: Highlights information critical to the user's understanding of the procedure.

Bold text stresses attention to the details of the procedure.

1.3 Important Notes and Warning Statements

Please read this Maintenance and Spare Parts Manual carefully and completely before attempting to store or perform maintenance on your QX valve actuator. Further installation, setup and operation instructions are available in the Installation and Operation manual (LMENIM3306) attached to the actuator declutch lever bracket at shipment.

☠ **WARNING:** Be aware of electrical hazards within the actuator and high-pressure hazards of the attached valve or other actuated device when installing or performing maintenance on your QX actuator. Failure to observe these precautions could result in serious bodily injury, damage to the equipment or operational difficulty.

☠ **WARNING:** Do not manually operate actuator with devices other than installed handwheel and declutch lever. Using additive force devices (cheater bars, wheel wrenches, pipe wrenches or other devices of this nature) on the actuator handwheel or declutch lever may cause serious personal injury and/or damage to the actuator or valve.

1.4 Reference Documents

- Protection, Control and Monitoring features of MX/QX Electric Actuators (Bulletin LMENTB2300)
- QX Control, Performance and Value in Quarter-turn Electric Valve Actuators (Bulletin LMENBR3302)
- QX Installation Manual (Bulletin LMENIM3306)
- QX Quick Mount and Start (Bulletin LMENIM3313)

1.5 This document applies to both QX – 90 degree actuators and all QXM-multi-turn actuators.

The latest revisions to these documents are available on-line from Flowserve Limitorque's website, www.flowserve.com or at www.limitorque.com

2

QX Actuator Subassembly

Figure 2.1 - Typical QX Actuator

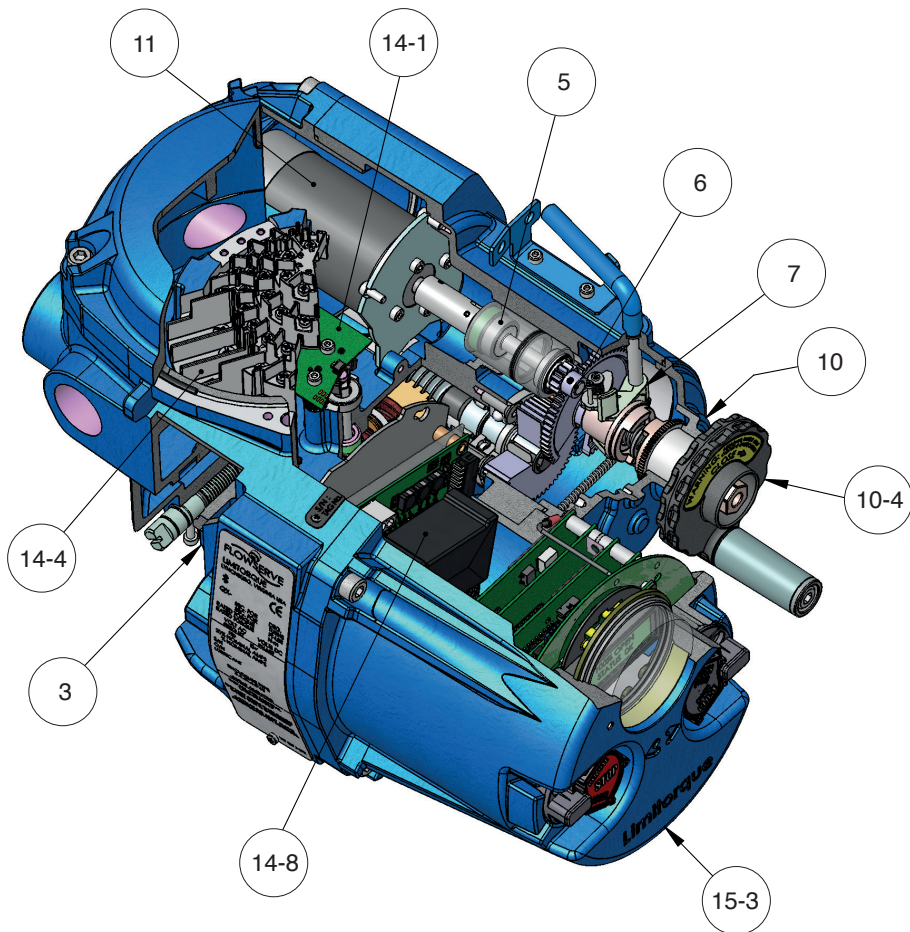

NOTE: QX-1 and 2 90° unit shown.

2.1 QX Actuator Subassembly Components

Table 2.1 - Typical QX Actuator Subassembly

Item Number	Description
3	Baseplate
5	Motor cartridge
6	Clutch shaft
7	Clutch fork
10	Handwheel cover
10-4	Handwheel
11	Motor
14-1	Encoder
14-4	Terminal block
14-8	Power controls
15-3	Controls cover

2.1.1 Product Description

Your QX actuator controls the opening and closing travel of valves and other actuated devices. OPEN and CLOSED limits are protected by an absolute encoder that provides optical sensing of valve position and measures valve position in both motor and handwheel operation. No battery or backup power supply is required. Output torque is derived from current, voltage and temperature. If the preset torque is exceeded, the motor shuts off. As a result of this reliable and advanced protection technology, all valve and other actuated devices are protected from potential damage from overload, improper seating and foreign obstructions.

A range of control and network options is available which can be easily added to the control capabilities already available on a standard actuator. Contact your local Limitorque distributor or Limitorque sales office for further information.

2.1.2 Storage

Storage Recommendations

Your QX actuator is double-sealed and weather-proof as shipped, even for explosion-proof applications, providing all compartment covers and cable entry plugs are left intact. Actuators should be stored in a clean, dry, protected warehouse until ready for installation. If actuators must be stored outdoors, they should be stored off the ground and high enough to prevent being immersed in water or buried in snow.

Preferred Storage Orientation

Your QX actuator should be stored with terminal compartment in the vertical position and the drive base down to obtain optimum service life.

2.1.3 Unit Weights

Table 2.2 - QX Unit Weights

Unit	lb.	kg
QX-1	40	18
QX-2	42	19
QX-3	80	36
QX-4	80	36
QX-5	80	36

NOTE: Weights include B4 stem nut and lubricant.

2.2 Product Identification

2.2.1 Initial Inspection and Recording Suggestions

Upon receipt of the actuator, several steps should be initially followed to ensure condition of equipment and to establish proper record keeping.

1. After removing the actuator from the shipping carton or skid, thoroughly examine it for any physical damage which may have occurred during shipment. If you note any damage, immediately report the damage to the transport company and call Limitorque for further assistance.
2. A nameplate with important information is attached to each actuator. Record the following information for use when you need to contact Limitorque with any questions about your actuator:
 - Unit type/size
 - Flowserve Limitorque order number
 - Serial number

Figure 2.2 - QX Nameplate

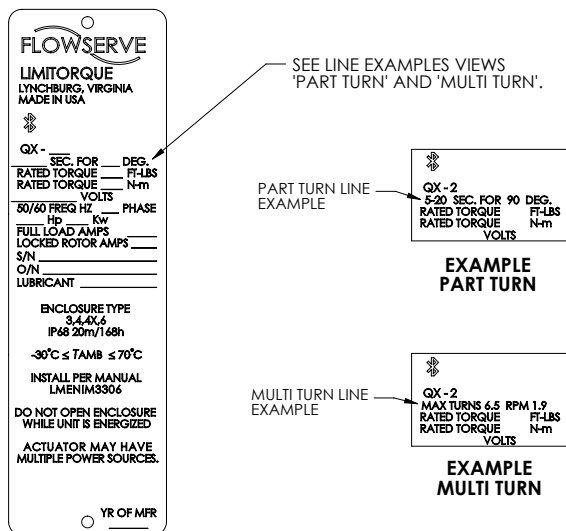

Figure 2.3 - QX Nameplate



2.3 Maintenance

2.3.1 Recommended Maintenance

Under normal operating conditions, the QX is a maintenance-free actuator. Therefore, for normal applications, the actuator will require no formal maintenance program. However, if the actuator is used under severe service conditions or operated in a Hazardous Location, the following maintenance procedures are required:

1. Check the oil level every 50 hours of operation at a minimum. Where conditions are severe due to frequent operation or high ambient temperatures, a more regular inspection interval should be maintained.
2. Change the gear oil every 100 hours of operation. See section 2.3.2 Unit Lubrication.
3. All ball bearings, oil seals, O-rings and quad-rings are to be replaced after 450 hours of operation. See sections 2-3-2 thru 2-3-3.

Clean and lubricate the valve stem regularly to avoid torque build-up and wear due to silting and corrosion. Infrequent operation can lead to corrosion and contamination of the valve stem thread lubricant. Check any thrust bearings that are fitted to the actuator for proper lubrication at regular intervals.

2.3.2 Unit Lubrication

Change oil every 100 hours of operation or if water or other foreign material is found during oil inspection.

Oil Level Inspection and Fill Criteria

To avoid pressurization of the gearcase, the following recommended oil capacities should not be exceeded: (Reference Table 2.3 for oil capacities when mounted in varying positions)

- Actuator viewed in upright position (terminal compartment up / base down) Oil level should be approximately 1 inch (25.4 mm) below the outer surface of the housing at the oil fill port.
- Actuators mounted in other orientations than the upright position should have their oil capacities maintained.

Fill through the highest oil fill port until the oil is at a level that will contact the bottom of the plug when installed in the oil fill port.

NOTE: Do not overfill! Oil will expand during actuator operation. Actuators are shipped with an oil volume suitable for any mounting position. When checking the factory-supplied oil level, excess oil may drain from the highest oil fill port due to the various mounting orientations of each application.

Table 2.3 QX-1 thru 5 Oil Capacities

Unit Description	Fluid Ounces	Litres
QX 1/2	26	0.77
QX 3/4/5	80	2.36

Lubrication Data

Oil Specification – all models

-30°C to +70°C (-22o to + 158o F) units require oil per Petro-Canada SHB-68 or Mobil SHC626

-60°C to +40°C (-76o to + 104o F) units require oil that is 50% Petro Canada SHB-68 with 50% Soltex PA04

Figure 2.4 - QX Oil fill /Plug Locations (QX-1 thru 5)

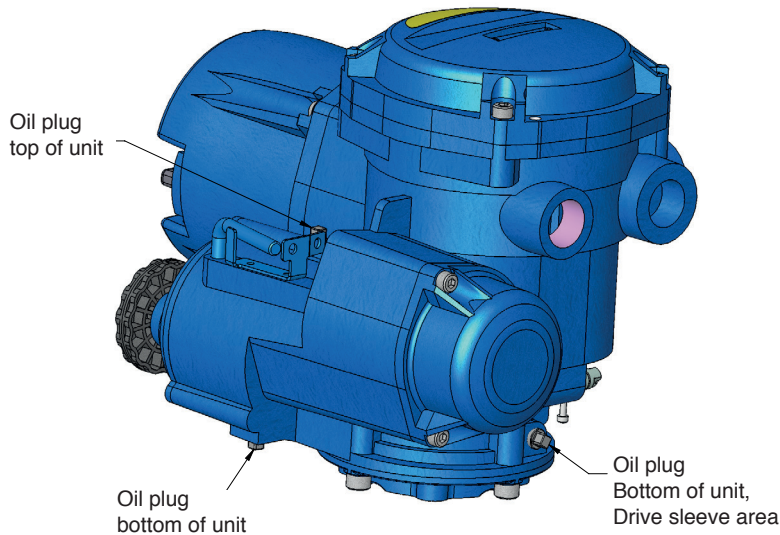

2.3.3 O-Ring and Lubrication

O-rings and seals should be replaced any time an actuator is disassembled. Lubricate with a substance that is compatible with Buna N seals.

2.4 Subassembly Removal and Remounting Procedures

This manual divides each QX actuator subassembly into a Removal and Remounting procedure. Use the following procedures to remove subassemblies for inspection, repair or replacement. Some subassemblies require prior subassembly removal before allowing the desired subassembly removal. Note the First Remove instructions at the beginning of each subassembly removal procedure. Remove these subassemblies first, and then remove the desired subassembly according to the instructions. Once removed, evaluate subassembly components to determine requirement for a new subassembly. If a new subassembly is required, see Section 2.5. Once components have been identified and replaced, remount following the appropriate Remounting procedures.

2.5 How to Order Replacement Subassemblies

2.5.1 Replacement Parts

Replacement parts are sold in modular subassemblies; therefore, when part replacement is required, order parts at the subassembly levels as shown in this manual. Parts may be ordered from your local Limitorque representative (www.flowserve.com) or direct from the factory:

Telephone: 1-434-528-4400

Fax: 1-434-845-9736

Please have the following information, found on the actuator nameplate, available to help us facilitate your order:

- Unit type/size
- Limitorque order number
- Serial number

2.5.2 Return Procedure

When parts are identified for warranty or other component replacement, a Return Material Authorization (RMA) must be obtained from Flowserve. Contact factory for a RMA number (see contact information in section 2.5.1). All returned parts must be accompanied by documentation with the following information to obtain credit for returned goods:

- Return Material Authorization (RMA)
- Unit type/size
- Flowserve Limitorque order number
- Serial number

Return parts to the address listed below:

Limitorque Actuation Systems
 5114 Woodall Road
 Lynchburg, VA 24502

2.5 Screw Preload (Torque)

Torque applied to each size screw used in the QX:

Table 2.4 - Screw Preload Torque

Screw	Screw Preload
M10	10-12 ft-lbs
M10 used on Base Plate QX-3 / 4 / 5	17-20 ft-lbs
M8	6-8 ft-lbs
M6	24-36 inch lbs
M5	15-20 inch lbs
M4	8-12 inch lbs
M3	60-70 inch ounces
M2	18-22 inch ounces

3

Remove Actuator from Mounting Adapter

3.1 Actuator Removal with Type B4/B4E Base (Torque)

3.1.1 Removal (Type B4/B4E Base)

Step 1

⚠ WARNING: Hazardous Voltage! Turn off all power sources to actuator before removing actuator from mounting plate. Power sources may include main power or control power. If necessary, disconnect incoming power leads L1, L2, L3, and control wiring from the terminal block.

Figure 3.1 - Torque Nut, F/FA-10, QX-1 & 2 and F/FA-12 and -14, QX-1 thru 5

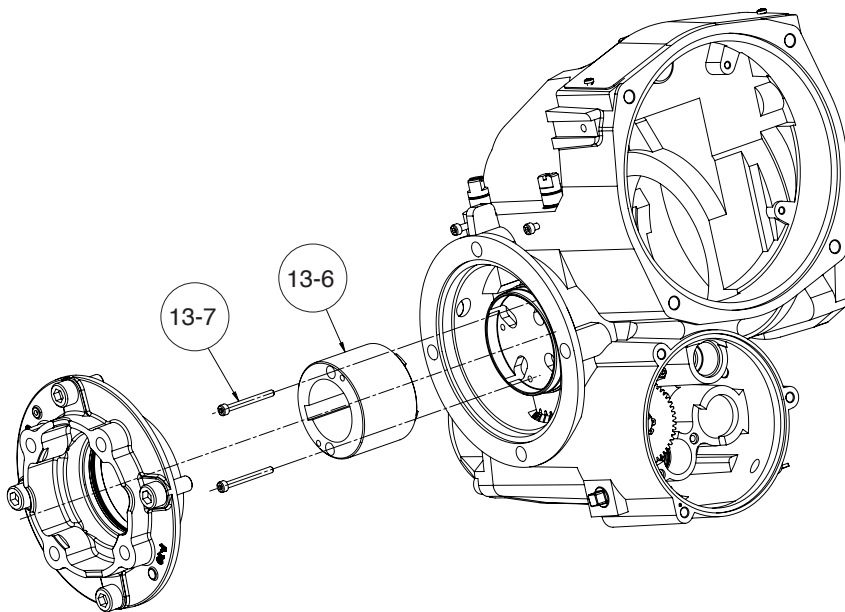
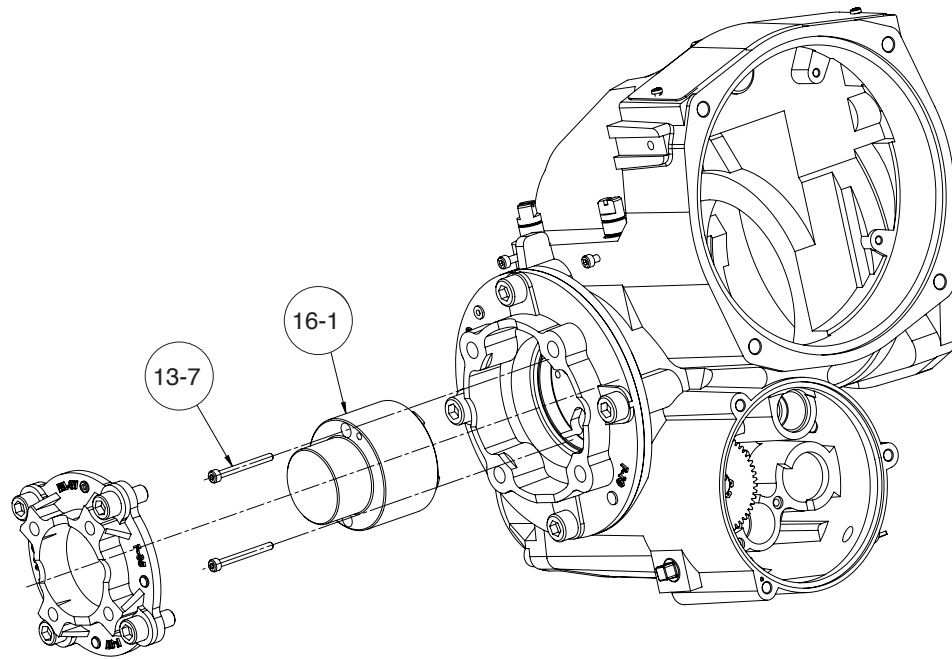

Table 3.1 Torque Nut, F/FA-05 and -07, QX-1 & 2 and F/FA-10, QX-1 thru 5

ITEM NUMBER	DESCRIPTION	QTY.
13-7	SCOKET HEAD CAP SCREW	1
16-7	TORQUE NUT	1

Figure 3.2 - Torque Nut, F/FA-05 and -07, QX-1& 2 and F/FA-10, QX-1 thru 5



Remove the bolts that secure the actuator to the mounting adapter. If type B4 or B4E base is used in addition to the standard type B4 or B4E baseplate, you may leave the B4 base attached to the mounting adapter and remove the actuator only. Or if required, you may remove the bolts that mount type B4 base to mounting adapter. This will allow actuator removal along with optional B4 base.

Step 2

⚠ WARNING: Potential high-pressure vessel! Before disassembling your actuator, ensure that the valve or other actuated device is isolated and is not under pressure.

Lift the actuator from mounting adapter.

3.1.2 Remounting (Type B4/B4E Base)

Step 3

Ensure stem nut (#1-22) is secured inside actuator drive sleeve with retaining ring (#1-23). Lower the actuator onto the mating component, making sure to align stem nut key and keyway with mating component.

Step 4

Ensure that the actuator and mounting adapter flange mating holes are aligned correctly.

Step 5

⚠ WARNING: Hazardous Voltage! Turn off all power sources before rewiring incoming power leads L1, L2, L3, and control wiring in the terminal block.

Secure the actuator to the mounting adapter with mounting bolts.

Step 6

Reconnect incoming power leads L1, L2, L3, and control wiring to the terminal block. Restore power source when ready for operation.

3.2 Actuator Removal with Type A1/A1E Base (Thrust) – QXM only

3.2.1 Optional Thrust Base Assembly QX-1 & 2

Table 3.2 - Optional Thrust Base Assembly

ITEM NUMBER	DESCRIPTION	QTY.
16-10	TORQUE NUT	1
16-11	BUSHING	1
16-12	O'-RING	1
16-13	O'-RING	1
16-14	ADAPTER PLATE	1
16-15	SOCKET HEAD CAP SCREWS	4
16-16	SPACER, PILOT, ISO ONLY	1
16-17	THRUST BASE ASSEMBLY	1

Figure 3.3 - Optional Thrust Base Assembly

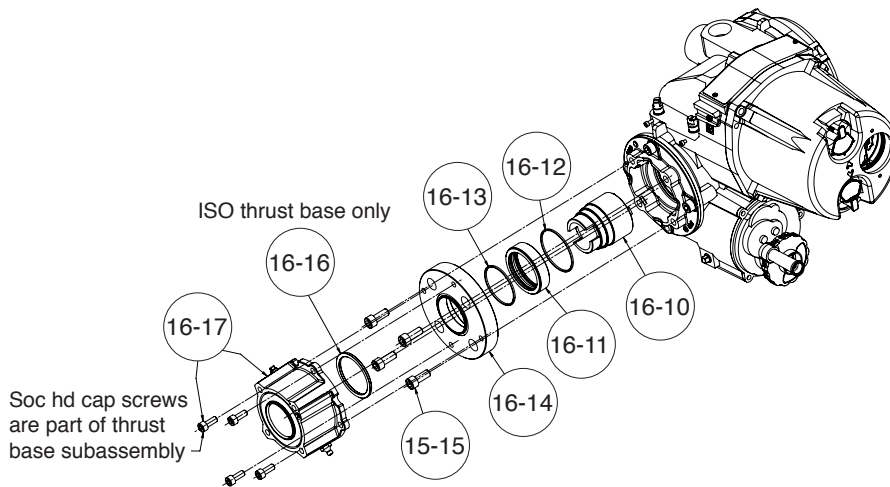

3.2.2 Optional thrust base assembly removal.

Step 1

Remove the four (4) screws (#) and remove the thrust base subassembly (#16-17) by sliding the base down. If base is ISO remove the spacer (pilot) (#16-16).

Step 2

Remove the four (4) screws (# 16-15) and remove the adapter plate (#16-14) and torque nut (#16-10). Item (#16-11) bushing is pressed into adapter plate and cannot be removed. The torque nut is held in place by the unit drive sleeve and the bushing (#16-11).

Table 3.3 - Optional Thrust Base Subassembly

ITEM NUMBER	DESCRIPTION	QTY.
10-1	HOUSING, THRUST BASE	1
10-2	PILOT, THRUST BASE	1
10-3	THRUST NUT	1
10-6	SOCKET HEAD CAP SCREWS	1
10-7	FLAT WASHER	1
10-8	RELIEF FITTING	1
10-10	SOCKET HEAD CAP SCREWS	4
10-11	GREASE FITTING	1
10-12	NEEDLE BEARING	2
10-13	THRUST RACE	2
10-14	QUAD RING	1
10-15	O'-RING	1
10-16	QUAD RING	1

Figure 3.4 - Optional Thrust Base Subassembly

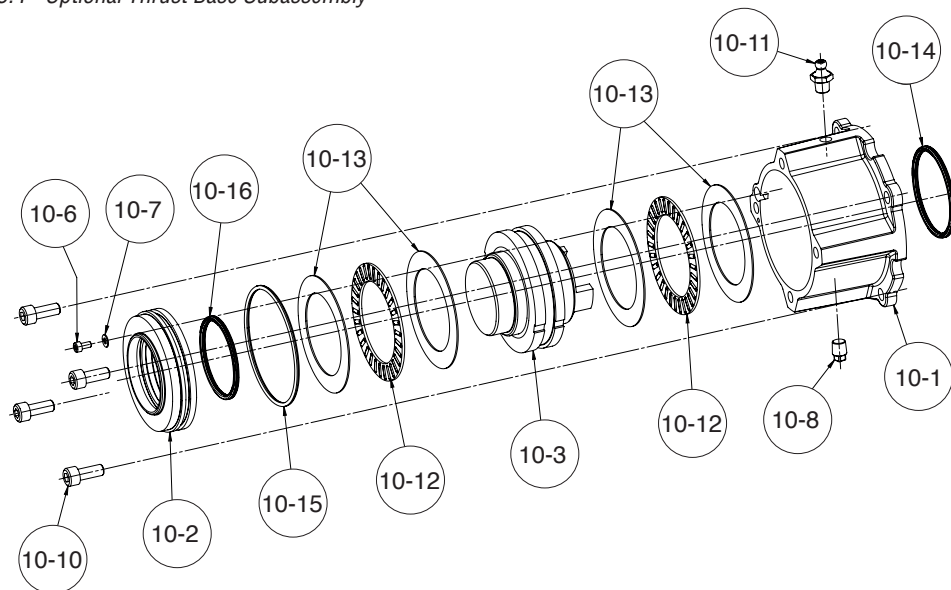

3.2.3 Thrust base remounting

Step 1

Place QX torque nut (#16-10) into unit drive sleeve (#1-11) aligning nut lugs to drive sleeve slots.

Step 2

Lightly lubricate 'O'-rings (#16-12) and (#16-13) and insert into bushing (#16-11) that is pressed into adapter plate (#16-14). Slide adapter plate and bushing over end of torque nut and aligning to unit baseplate. Insert screws (#16-15) into adapter plate holes and tighten.

Step 3

Align thrust base subassembly nut lugs (#10-3) with QX torque nut (#16-10) slots and slide thrust base on to QX unit baseplate aligning pilots. Note; For ISO thrust base pilot spacer (#16-16) must be used to align thrust base to QX baseplate. Insert screws (#10-10) into thrust base holes and tighten

NOTE: Two procedure options are available for removing the actuator and the thrust base:

1. Remove actuator from the thrust base, leaving the base mounted to the mounting flange or removing the thrust base separately
2. Remove actuator and thrust base as a unit from the mounting flange.

3.2.4 Removal (Type A1/A1E Base) Actuator Removal Separate from Thrust Base

STEP 1

⚠ WARNING: Hazardous Voltage! Turn off all power sources to actuator before removing actuator from mounting plate. Power sources may include main power or control power. If necessary, disconnect incoming power leads L1, L2, L3, and control wiring from the terminal block.

Remove the bolts (#10-10) that secure the actuator to the thrust base assembly (#10).

STEP 2

⚠ WARNING: Potential high-pressure vessel! Before disassembling your actuator, ensure that the valve or other actuated device is isolated and is not under pressure.

Lift actuator from thrust base assembly (#10).

STEP 3

⚠ WARNING: Potential for actuated device to change position! The thrust base will maintain position only if non-backdriving thread lead is used. Ensure proper thread lead is used in your application before allowing thrust base to be used for main- taining position when actuator is removed.

Thrust base removal (if required)

The valve position will be maintained if a locking thread lead is used on the valve stem. If thrust base removal is required, use the following removal procedure.

Remove the bolts that secure the thrust base to the mounting adapter.

STEP 4

Rotate the thrust base (#10) until it feeds off the threaded stem.

3.2.5 Remounting (Type A1/A1E Base) Actuator Remounting Separate from Thrust Base

STEP 5

Thrust base remounting (if required)

Ensure the thrust base stem nut has the two lugs positioned upward to engage with the drive sleeve slots when actuator is reinstalled onto thrust base. Thread thrust base back onto mounting adapter.

STEP 6

Secure thrust base to mounting adapter with mounting bolts.

STEP 7

Actuator remounting

Lower the actuator onto the thrust base, making sure thrust nut lugs align and properly engage with drive sleeve slots.

STEP 8

Install bolts (#10-10) to secure the actuator to the thrust base assembly (#10).

STEP 9

- ⚠ **WARNING:** Hazardous Voltage! Turn off all power sources before rewiring incoming power leads L1, L2, L3, and control wiring in the terminal block.

Reconnect incoming power leads L1, L2, L3, and control wiring to the terminal block. Restore power source when ready for operation.

3.2.6 Removal (Type A1/A1E Base) Actuator and Thrust Base as a Unit

STEP 1

- ⚠ **WARNING:** Hazardous Voltage! Turn off all power sources to actuator before removing actuator from mounting plate. Power sources may include main power or control power. If necessary, disconnect incoming power leads L1, L2, L3, and control wiring from the terminal block.

Actuator and thrust base removal

Remove the bolts that secure the actuator and thrust base (#10) to the mounting adapter.

STEP 2

- ⚠ **WARNING:** Potential high-pressure vessel! Before disassembling your actuator, ensure that the valve or other actuated device is isolated and is not under pressure.

Declutch the actuator to manual mode.

STEP 3

Rotate the handwheel until the actuator lifts off the threaded stem.

3.2.7 Remounting (Type A1/A1E Base) Actuator and Thrust Base as a Unit

STEP 4

Actuator and thrust base remounting

Declutch the actuator to manual mode. Lift actuator up to the threaded stem and carefully align threads with thrust base threaded stem nut.

STEP 5

Rotate the handwheel to lower the actuator along the threaded stem and onto the mounting adapter plate.

STEP 6

Install the mounting bolts to secure the actuator and thrust base (#10) to the mounting adapter.

STEP 7

- ⚠ **WARNING:** Hazardous Voltage! Turn off all power sources before rewiring incoming power leads L1, L2, L3, and control wiring in the terminal block.

Reconnect incoming power leads L1, L2, L3, and control wiring to the terminal block. Restore power source when ready for operation.

4 Mechanical Assemblies

4.1 Motor subassembly. QX-1 thru 5.

NOTE: Proper motor testing is required when replacing motor. Consult your Limitorque representative or the Limitorque factory to replace with correct motor.

Table 4.1 - Motor Parts List

ITEM NUMBER	DESCRIPTION	QTY.
11	MOTOR	1
13-4	SOCKET HEAD CAP SCREWS	5
15-1	'O'-RING	1
15-2	COVER, MOTOR	1
15-6	SOCKET HEAD CAP SCREWS	3

Figure 4.1 - Motor Cover and Motor Subassembly Removal

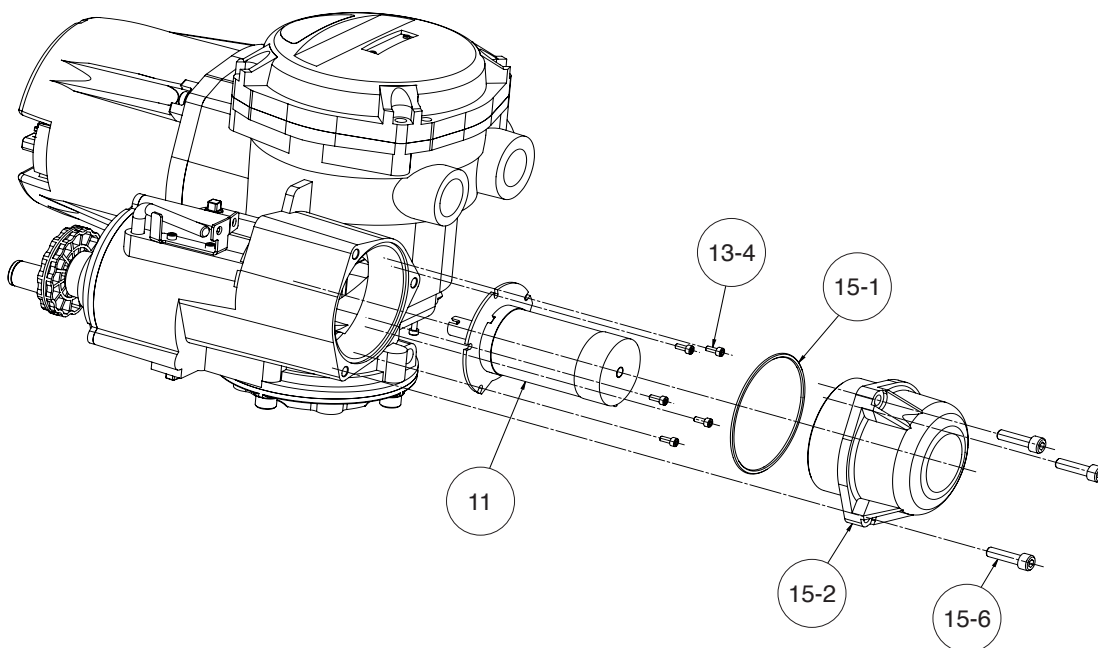

4.1.1 Motor subassembly Removal. QX-1 thru 5.

Step 1

⚠ WARNING: Hazardous Voltage! Turn off all power sources to actuator before removing motor assembly. Power sources may include main power or control power.

Using a M6 hex key, remove the three M8 screws (#15-6) that mount the motor cover and remove cover (#15-2) and 'O'-ring (#15-1) from unit assembly.

NOTE: The controls cover must also be removed to disconnect the motor cable from the motor controller if the motor is to be completely removed. See Section 6.2 for controls cover removal, Section 7.1 for motor connector placement.

Step 2

⚠ CAUTION: The rotor is not connected to the motor housing; when removing the motor, ensure the rotor is carefully removed and not dropped from the motor housing.

Using a M3 hex key, remove the five M4 screws (#13-4) that mount the motor assembly. Remove the motor assembly (#11) from unit by sliding motor out of the unit and if needed disconnect motor connector from motor control board and slide wiring out of unit.

Table 4.2 Motor Subassembly, Item 11

ITEM NUMBER	DESCRIPTION	QTY.
11-1	MOTOR	1
11-2	COUPLING	1
11-3	SPIRAL PIN	1
11-4	PLATE, MOTOR MOUNTING	1
11-5	SOCKET HEAD CAP SCREWS	1

Figure 4.2 - Motor Subassembly, Item11

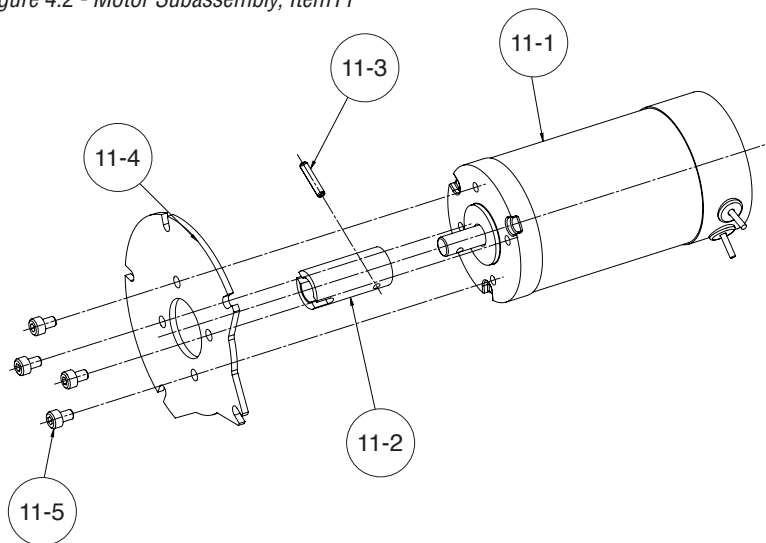

4.1.2 Motor subassembly Remounting. QX-1 thru 5.

Step 1

⚠ WARNING: Hazardous Voltage! Turn off all power sources to actuator before removing motor assembly. Power sources may include main power or control power.

If motor wiring was removed reroute wiring thru housing over to the motor control board. Do not connect motor wiring connector until motor is mounted in unit. Rotate motor coupling slot to correct position on motor to match motor cartridge pin orientation noting motor bracket position to unit housing per Figure 4.3 and slide motor assembly into housing aligning the motor coupling bore and slot to the motor cartridge shaft and pin and the motor bracket to the unit housing.

(See Figure 4.3 listed for motor bracket orientation to unit housing).

Figure 4.3 - Motor Bracket Orientation View

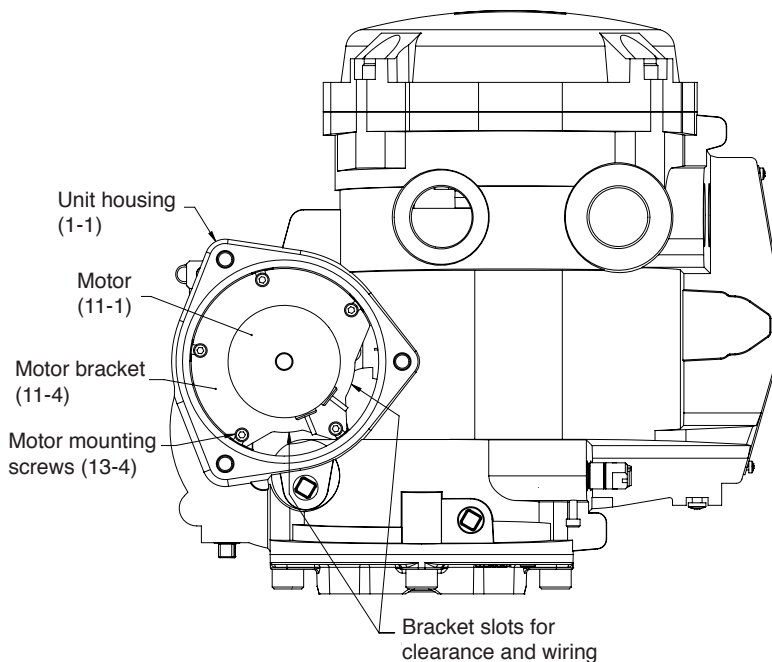

Step 2

Reconnect motor wiring connector to motor control board. Install the five M4 screws (#13-4) and tighten.

(See section 7 for motor wiring connection).

Step 3

Lightly lubricate 'O'-ring (#15-1) and install around motor cover spigot/pilot (#15-2). Slide motor cover spigot/pilot into the unit housing.

Step 4

Fit the 3 screws (#15-6) into motor cover mounting holes and tighten to torque in section 2.

4.2 Handwheel cover subassembly, QX-1 thru 5.

NOTE: Sections 4.2 – 4.8 require the actuator to be removed from the mounting plate and the oil drained.

Table 4.3 - Handwheel Cover Assembly

ITEM NUMBER	DESCRIPTION	QTY.
10	HANDWHEEL COVER ASSY	1
13-1	DOWEL PIN	1
13-2	'O'-RING	1
13-3	SOCKET HEAD CAP SCREW	3

Figure 4.4 - Handwheel Cover Assembly

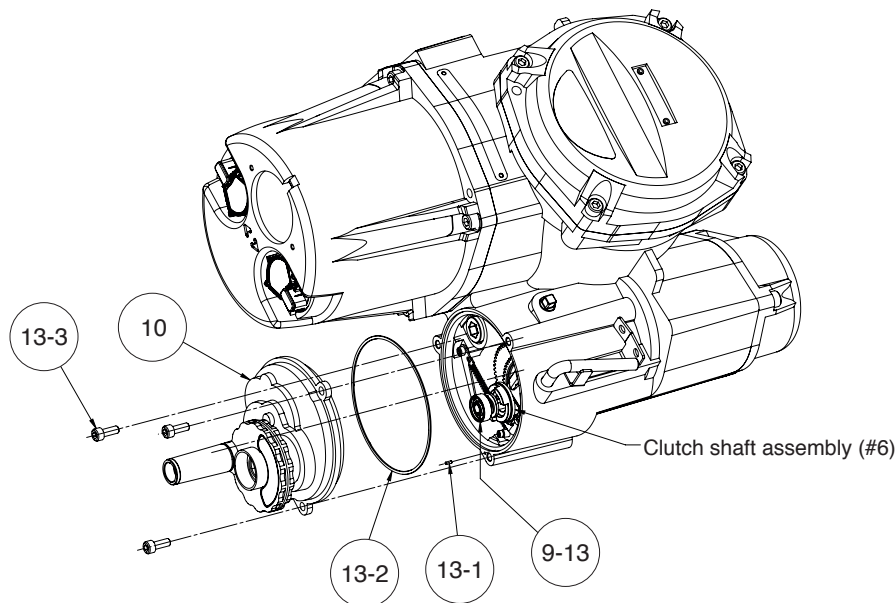

⚠ WARNING: Do not manually operate the actuator with devices other than the installed handwheel and declutch lever. Using force beyond the ratings of the actuator and/or additive forces such as cheater bars, wheel wrenches, pipe wrenches, or other devices on the actuator handwheel or declutch lever may cause serious personal injury and/or damage to the actuator and valve.

4.2.1 – Handwheel cover subassembly Removal, QX-1 thru 5

Step 1

⚠ WARNING: Potential to operate while dangerous mechanical parts are exposed during subassembly removal. To prevent injury, turn off all power sources to actuator before removing top-mounted handwheel assembly. Power sources may include main power or control power.

Using a M5 hex key, remove the three M6 screws (#13-3) that mount the handwheel cover and remove the handwheel cover assembly (#10) and 'O'-ring (#13-2) from unit assembly. Dowel pin (#13-1) is pressed into the unit housing.

Note: QX-1 thru 5 Ball bearing (#9-13) may also come out with the handwheel assembly, QX-3,4 and 5 Ball bearing (#9-3) may also come out with the handwheel assembly.

Table 4.4 - Handwheel Cover Subassembly Item 10. QX -1 & 2

ITEM NUMBER	DESCRIPTION	QTY.
10-1	COVER, HANDWHEEL	1
10-2	'O'-RING	1
10-3	SHAFT, HANDWHEEL	1
10-4	HANDWHEEL SUBASSEMBLY	1
10-5	RETAINING RING	1

Figure 4.5 - Handwheel Cover Subassembly, Item 10. QX-1 & 2

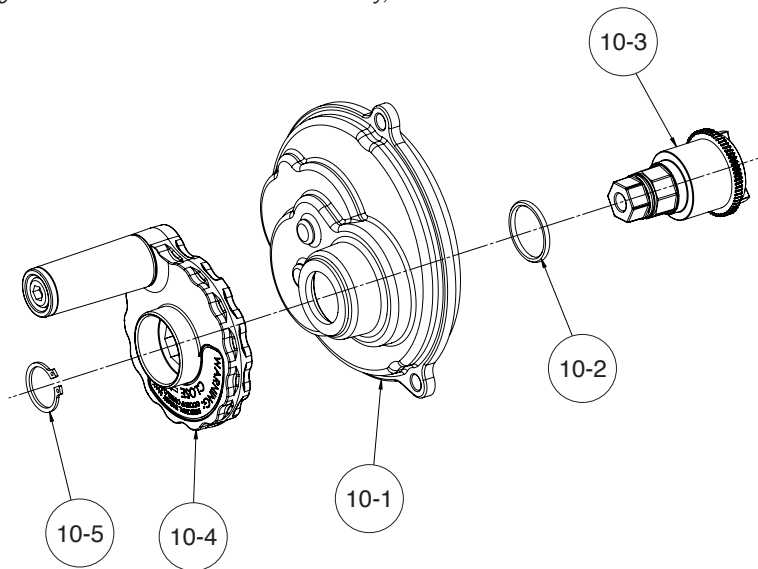

Table 4.5 - Handwheel Cover Subassembly, Item 10. QX-3 thru 5

ITEM NUMBER	DESCRIPTION	QTY.
10-1	COVER, HANDWHEEL	1
10-2	'O'-RING	1
10-3	SHAFT, HANDWHEEL	1
10-4	HANDWHEEL SUBASSEMBLY	1
10-5	WASHER	2
10-6	HEX NUT	1

Figure 4.6 - Handwheel Cover Subassembly, Item 10. QX-3 thru 5

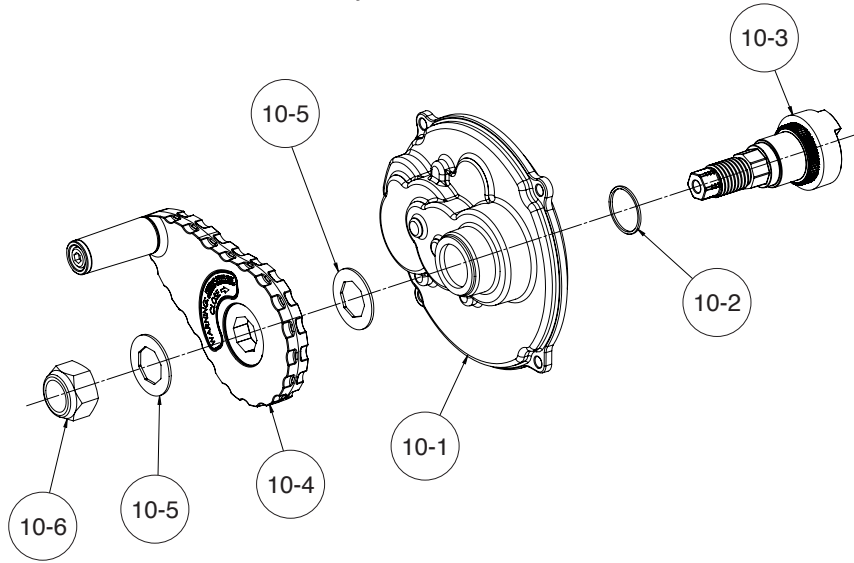
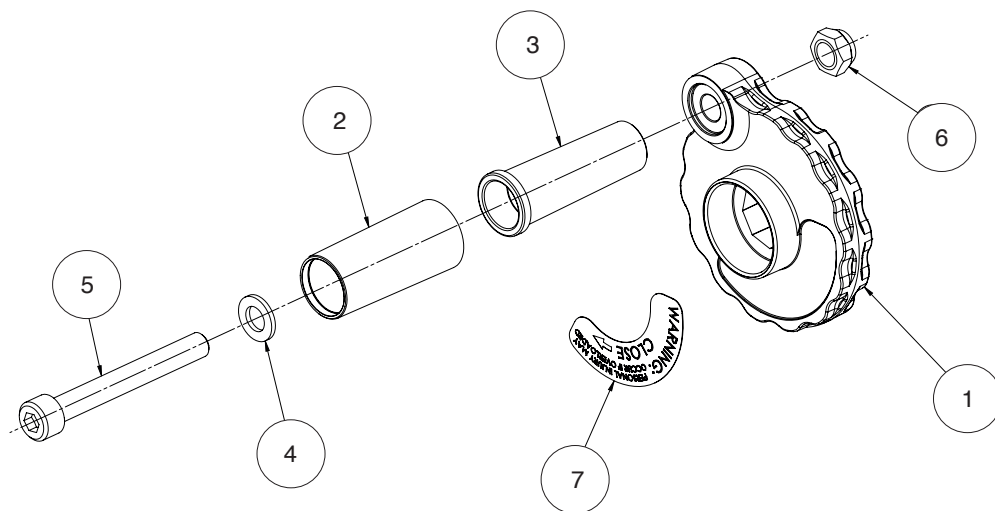

Table 4.6 - Handwheel Subassembly, Item 10-4

ITEM NUMBER	DESCRIPTION	QTY.
1	HANDWHEEL	1
2	SPINNER	1
3	SPINNER ROD	1
4	FLAT WASHER	1
5	SOCKET HEAD CAP SCREW	1
6	HEX NUT	1
7	HANDWHEEL LABEL	1

Figure 4.7 - Handwheel Subassembly, Item 10-4. QX-1 & 2 shown.



4.2.2 Handwheel Cover Assembly Remounting

Step 1

Lightly lubricate 'O'-ring (#15-2) and install around handwheel cover subassembly pilot (#10). Slide ball bearing (#9-13) back on end of clutch assembly if bearing was removed. Slide handwheel cover assembly pilot (#10) into the unit housing assuring the ball bearing aligns in handwheel shaft bore and dowel pin (13-1) aligns with the pin hole in cover.

NOTE: for QX-3,4 and 5 Handwheel assembly must also align with Ball bearing (#9-3) and the idle shaft assembly, see Figure 4.10 for view of idle shaft assembly location.

Step 2

Fit the 3 screws (#13-3) into handwheel cover mounting holes and tighten.

Check to make sure handwheel rotates freely.

4.3 Motor Cartridge Subassembly, QX-1 thru 5.

NOTE: Sections 4.2 – 4.8 require the actuator to be removed from the mounting plate and the oil drained.

4.3.1 Motor Cartridge Subassembly Removal, QX-1 thru 5.

Table 4.7 Motor Cartridge Assembly Removal

ITEM NUMBER	DESCRIPTION	QTY.
5	MOTOR CARTRIDGE	1
9-1	TAB, BRACKET	1
9-2	SOCKET HEAD CAP SCREW	1

Figure 4.8 - Motor Cartridge Assembly Removal

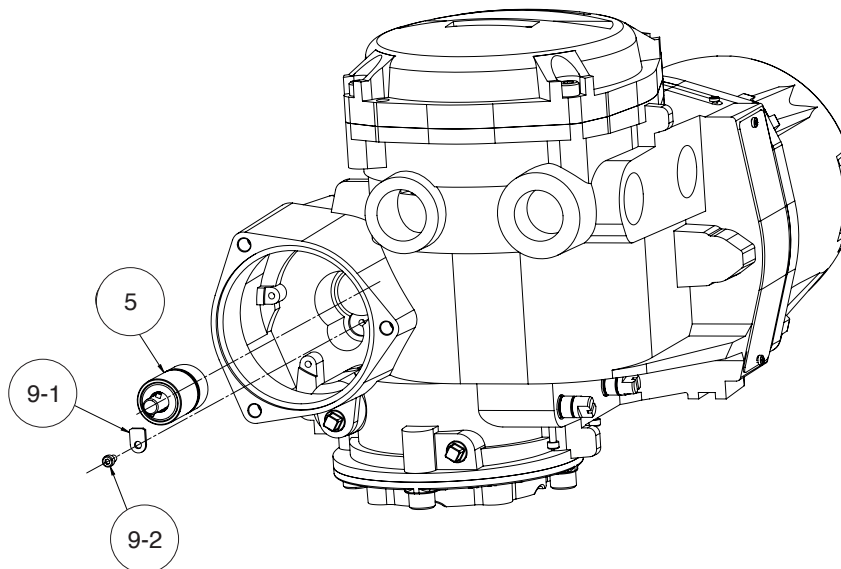

Step 1

Using a M3 hex key, remove the M4 screw (#9-2) and bracket (#9-1). Grab end of motor cartridge shaft and pull out cartridge subassembly.

Table 4.8 - Motor Cartridge Subassembly, Item 5

ITEM NUMBER	DESCRIPTION	QTY.
5-1	BUSHING	1
5-2	BALL BEARING	2
5-3	OIL SEAL	1
5-4	SHAFT	1
5-5	SPIRAL PIN	1
5-6	PINION, MOTOR	1
5-7	SPIRAL PIN	1
5-8	'O'-RING	1

Figure 4.9 - Motor Cartridge Subassembly, Item 5

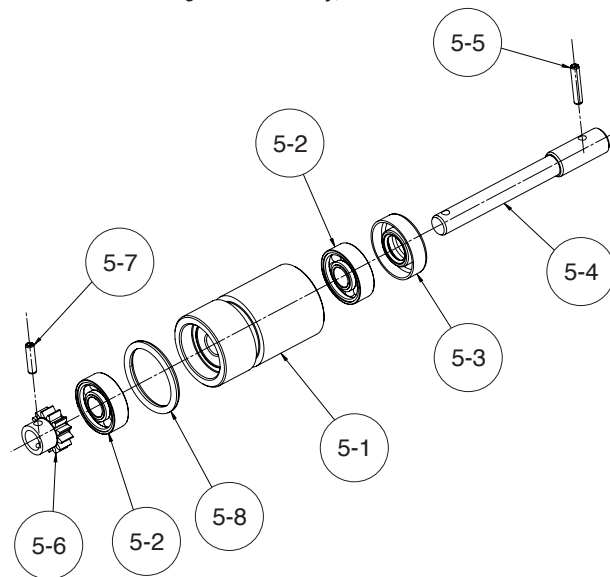

4.3.2 Motor Cartridge Assembly Remounting.

Step 1

Lightly lubricate 'O'-ring (#5-8). Push cartridge subassembly into housing bore assuring motor pinion (#5-6) aligns with motor gear on handwheel side of housing. Cartridge face should be even or below the counter bore face in the unit housing. Place bracket (#9-1) and screw (#9-2) in counter-bored area with M4 tap and tighten screw. Note: The bracket must sit flat on cartridge bushing and on the housing counter bore face.

4.4 Gearing and Clutching.

NOTE: Sections 4.2 – 4.8 require the actuator to be removed from the mounting plate and the oil drained.

Table 4.9 - Gearing and clutching, QX-1 & 2

ITEM NUMBER	DESCRIPTION	QTY.
6	CLUTCH SHAFT SUBASSEMBLY	1
7	CLUTCH FORK SUBASSEMBLY	1
9-4	PLATE, GEAR	1
9-5	SOCKET HEAD FLAT SCREW	2
9-6	BRACKET, DECLUTCH	1
9-7	SOCKET HEAD FLAT SCREW	2
9-8	'O'-RING	1
9-9	DECLUTCH LEVER	1
9-10	SOCKET HEAD CAP SCREW	1
9-11	EXTENSION SPRING	1
9-12	BRACKET	1
9-13	BALL BEARING	1
9-14	SOCKET HEAD CAP SCREW	1
9-15	SPACER, DECLUTCH SPRING	1

Figure 4.10 - Gearing and clutching, QX-1 & 2

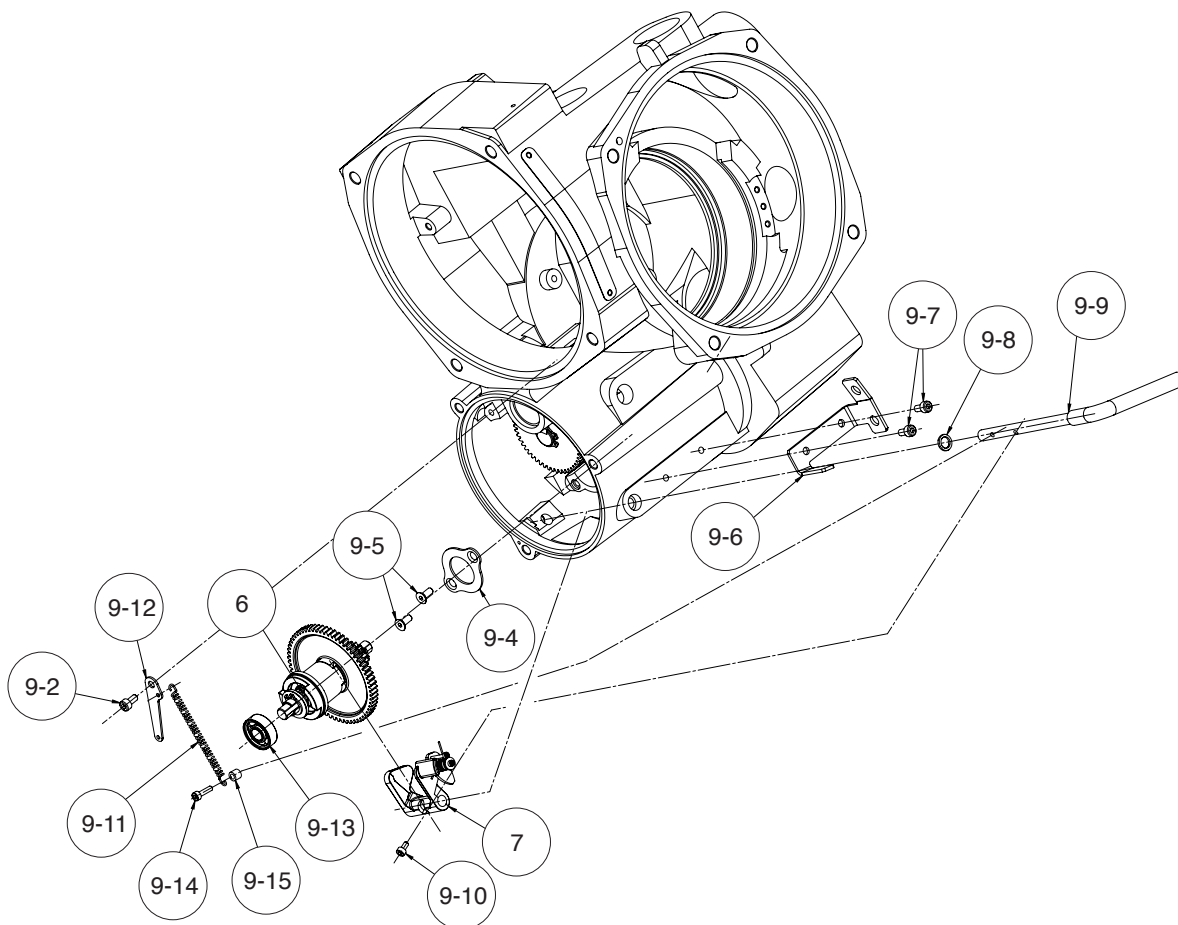
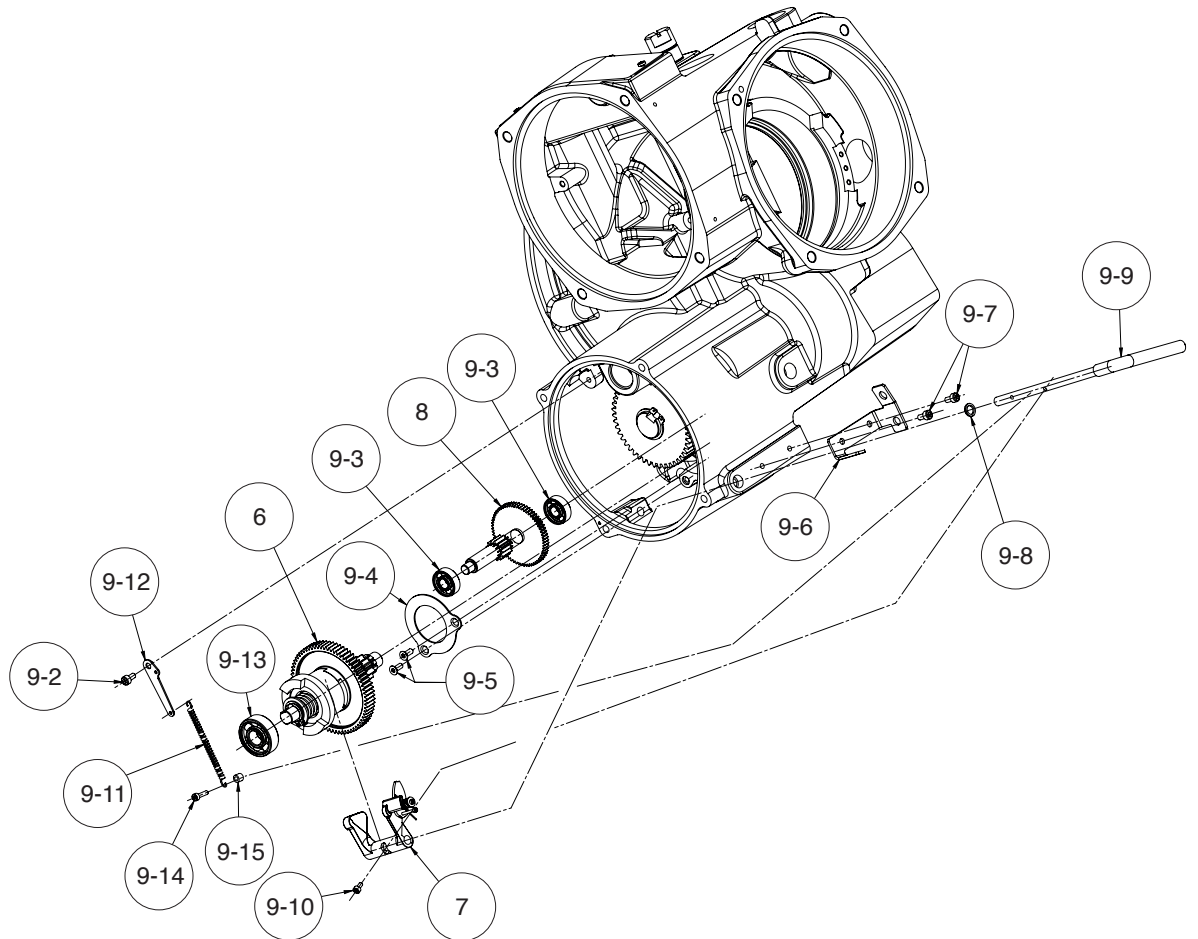

Table 4.10 - Gearing and clutching, QX-3 thru 5

ITEM NUMBER	DESCRIPTION	QTY.
6	CLUTCH SHAFT SUBASSEMBLY	1
7	CLUTCH FORK SUBASSEMBLY	1
8	SPUR IDLER SUBASSEMBLY	1
9-4	PLATE, GEAR	1
9-5	SOCKET HEAD FLAT SCREW	2
9-6	BRACKET, DECLUTCH	1
9-7	SOCKET HEAD FLAT SCREW	2
9-8	'O'-RING	1
9-9	DECLUTCH LEVER	1
9-10	SOCKET HEAD CAP SCREW	1
9-11	EXTENSION SPRING	1
9-12	BRACKET	1
9-13	BALL BEARING	1
9-14	SOCKET HEAD CAP SCREW	1
9-15	SPACER, DECLUTCH SPRING	1

Figure 4.11 - Gearing and clutching, QX-3 thru 5



4.4.1 Gearing and Clutching Removal.

⚠ WARNING: Potential to operate while dangerous mechanical parts are exposed during subassembly removal. To prevent injury, turn off all power sources to actuator before removing top-mounted handwheel assembly. Power sources may include main power or control power.

Step 1, Declutch lever spring return assembly.

Using a M3 hex key, remove the M4 screw (#9-2) and remove bracket (#9-12). Note that spring may be removed from bracket before removing screw (#9-2) using needle nose pliers. Using a M2.5 hex key remove M3 screw (#9-14), spring (#9-2) and spacer (9-15) from declutch shaft.

Step 2, Declutch lever, Clutch fork and clutch shaft subassembly.

Using a M2.5 hex key remove M3 screw (#9-10) holding clutch fork (#7) subassembly and declutch lever (#9-9) in place. Remove declutch lever (#9-9) and 'O'-ring (#9-8) by sliding lever up and out of housing. Gently pull out the clutch shaft subassembly (#6) and clutch fork subassembly (#7) out of unit thru the handwheel cover bore.

Step 3, Spur idler subassembly. QX 3/4/5 only.

Gently pull out spur idler subassembly (#8) out thru handwheel cover bore.

Step 4, Gear plate.

Using a M3 hex key, remove the two M4 screws (#9-5) holding in gear plate (#9-4) and remove.

Step 5, Declutch bracket.

Using a M3 hex key, remove the two M4 screws (#9-7) holding declutch bracket (#9-6) in place and remove.

Table 4.11 - Clutch Shaft Subassembly, Item 6. QX-1 & 2

ITEM NUMBER	DESCRIPTION	QTY.
6-1	CLUTCH SHAFT	1
6-2	MOTOR CLUTCH GEAR	1
6-3	PINION	1
6-4	RETAINING RING	1
6-5	CLUTCH	1
6-6	COMPRESSION SPRING	1
6-7	WASHER	1
6-8	RETAINING RING	1

Figure 4.12 - Clutch Shaft Subassembly, Item 6. QX-1 & 2

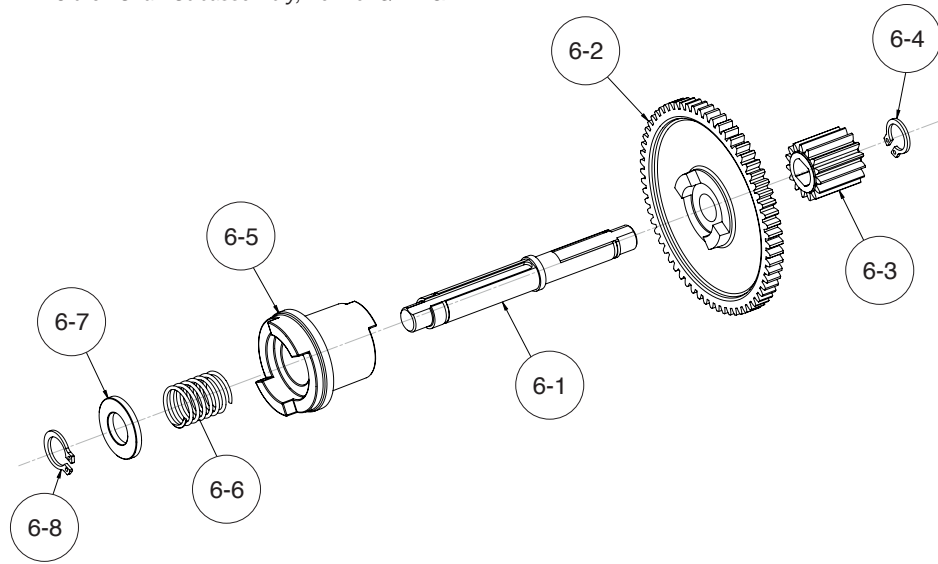

Table 4.12 - Clutch Shaft Subassembly Item 6. QX-3 Thru 5

ITEM NUMBER	DESCRIPTION	QTY.
6-1	CLUTCH SHAFT	1
6-2	MOTOR CLUTCH GEAR	1
6-5	CLUTCH	1
6-6	COMPRESSION SPRING	1
6-7	WASHER	2
6-8	RETAINING RING	2

Figure 4.13 - Clutch Shaft Subassembly, Item 6. QX-3 thru 5

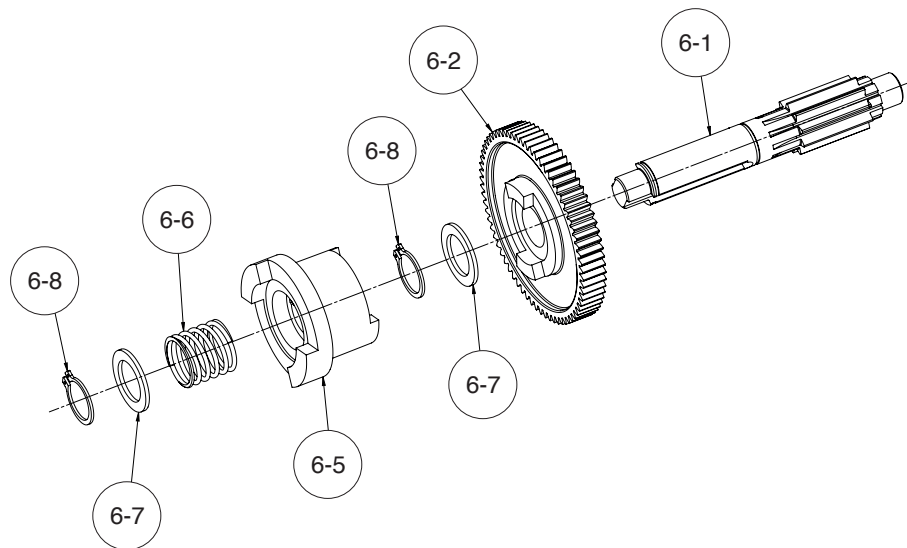
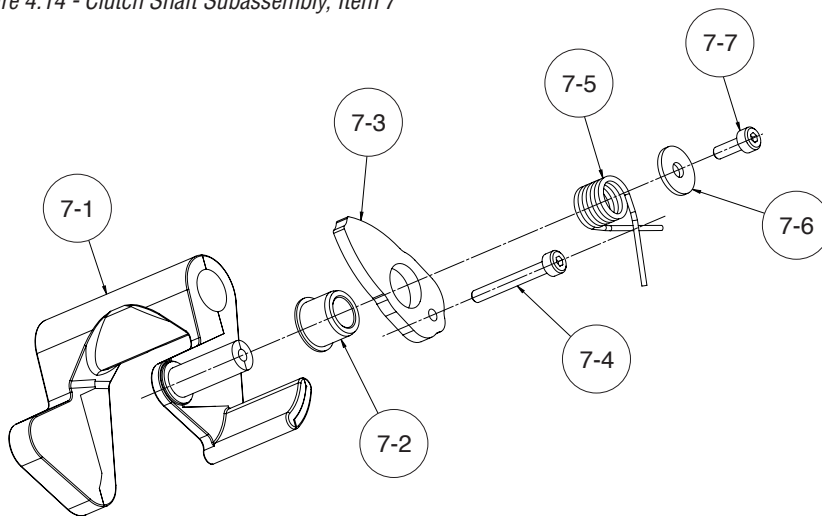

Table 4.13 - Clutch Shaft Subassembly Item 7

ITEM NUMBER	DESCRIPTION	QTY.
7-1	CLUTCH FORK	1
7-2	BUSHING	1
7-3	LATCH	1
7-4	SOCKET HEAD CAP SCREW	1
7-5	TORSION SPRING	1
7-6	WASHER	1
7-7	SOCKET HEAD CAP SCREW	1

Figure 4.14 - Clutch Shaft Subassembly, Item 7



4.4.2 Gearing and Clutching Remounting.

Step 1, Declutch bracket.

Place declutch bracket (#9-6) on to housing and secure with two M4 screws (#9-7) using a M3 hex key.

Step 2, Gear plate.

Before placing plate be sure that ball bearing item (#2-8) is in place (See Figure 4.18). The ball bearing will not slide thru place with gear plate mounted in housing. Place plate in housing on pad with the two M4 taps and with the plate counter sunk holes facing toward the handwheel cover aligning the plate big hole with the ball bearing (#2-8) bore. Note that the two counter sunk holes is for the two flat head screws (#9-5). Fit the two M4 flat head screws (#9-5) and tighten with a M2.5 hex key.

Step 3, Spur idler subassembly, QX-3 Thru 5 only.

Place ball bearing (#9-3) in housing bore, the bore without the bearing plate. Slide in the spur idler subassembly (#8) into bearing (#9-3) with the big gear end of the idler shaft first and engage with bearing (#9-3).

Step 4, Clutch fork and clutch shaft subassembly.

Slide the clutch fork subassembly (#7) over the clutch on the clutch shaft subassembly with the latch (#7-3) side pushed against the big gear face. Fit both clutch shaft and clutch fork subassemblies together into housing with the small pinion on clutch shaft fitting thru the gear plate (#9-4) and engaging shaft into ball bearing (#2-8). Note also that the clutch fork must be orientated with the latch up towards the declutch plate and the clutch fork bore in line with the declutch shaft.

Figure 4.15 - Clutch Fork Shaft Remounting

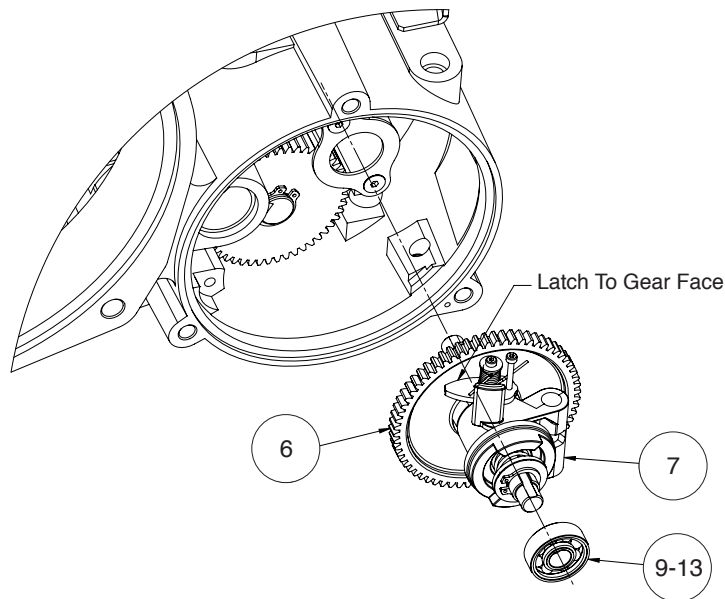

Step 5, Declutch lever and spring return assembly.

Lightly lubricate 'O'-ring (#9-8) and slide over declutch lever (#9-9). Slide declutch lever and 'O'-ring thru housing bore and down thru clutch fork bore and into the housing bore on other side ensuring that lever handle is installed properly with declutch bracket (#9-6), lever should not swing outwards. Secure fork with M3 screw (9-10) by inserting screw thru fork slot and into tap in lever and Tighten.

▲ CAUTION: Do not lift unit by declutch lever.

Slide spring end (#9-14) on M3 screw (#9-14), then slide spacer (#915) on to M3 screw and secure assembly to bottom tap in declutch lever. The spacer should be in-between the spring and declutch lever. Place M4 screw (#9-2) into spring bracket (#9-12). Hook the spring bracket on to the declutch return spring (#9-14) that has already been installed on to the lever, (See Figure 4.16) for correct hole for spring to hook into. Carefully stretch the spring and position the M4 screw in place on housing and tighten.

Figure 4.16 - Declutch Spring Assembly View. QX-1 & 2 shown

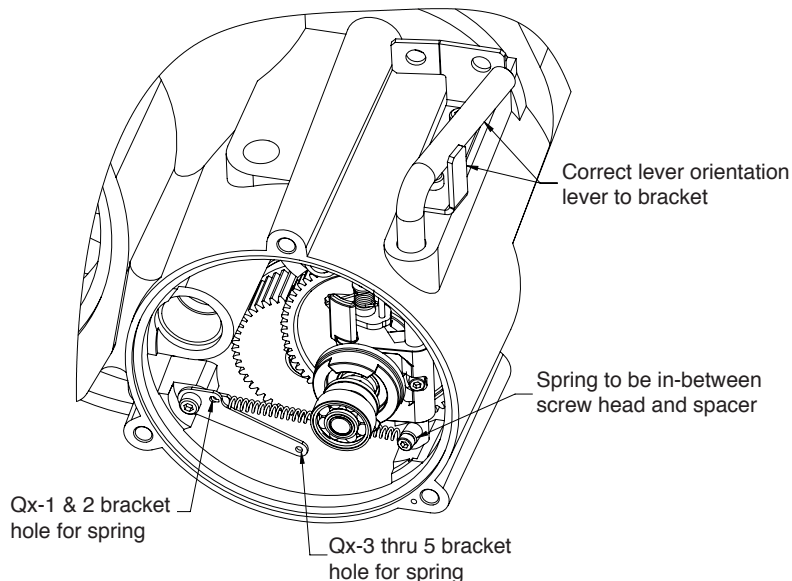

4.5 Pipe Plug

NOTE: Sections 4.2 – 4.8 require the actuator to be removed from the mounting plate and the oil drained.

Table 4.14 - Pipe Plug

ITEM NUMBER	DESCRIPTION	QTY.
12-1	PIPE PLUG	1

Figure 4.17 Pipe Plug

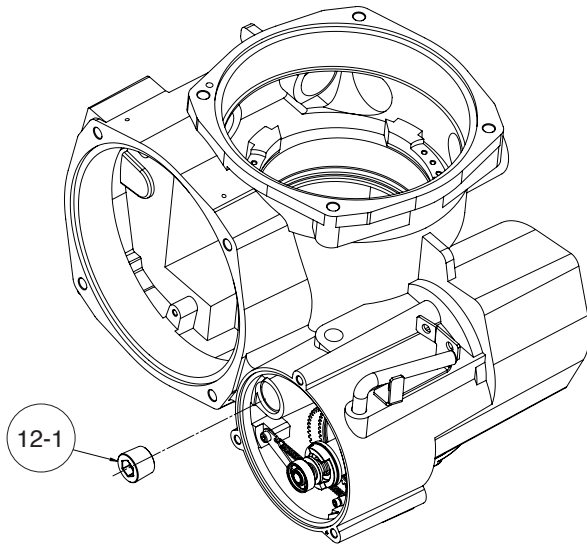

NOTE: If the pipe plug was removed, pipe sealant or tape must be applied to plug threads before remounting.

4.6 Baseplate

4.6.1 Baseplate Removal

NOTE: Sections 4.2 – 4.8 require the actuator to be removed from the mounting plate and the oil drained.

NOTE: If unit has a F/FA-05 or 07 QX-1 & 2, F/FA-10 QX-3 thru 5 base or Thrust base attached, these bases must be removed before removing the standard baseplate. See section 4-9 thru 4-10.

Table 4.15 Baseplate F/FA-10 QX-1 & 2, F/FA-12 & 14 QX-3 thru 5

ITEM NUMBER	DESCRIPTION	QTY.
3	BASEPLATE ASSEMBLY	1
4-1	'O'-RING	1
4-2	SOCKET HEAD CAP SCREWS	4

Figure 4.18 - Baseplate, F/FA-10 QX-1 & 2, F/FA-12 & 14, QX-3 thru 5

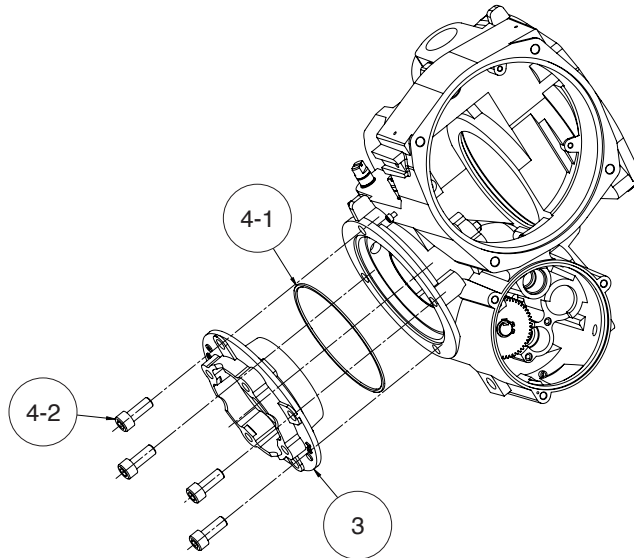

Step 1

Using a M8 hex key, remove the M10 screws (#4-2) and remove baseplate (#3).

Table 4.16 - Baseplate subassembly Item 3

ITEM NUMBER	DESCRIPTION	QTY.
3-1	BASEPLATE	1
3-2	QUAD RING	1
3-3	BUSHING	1

Figure 4.19 - F/FA-10 QX-1 & 2, F/FA-12 & 14, QX-3 thru 5 Baseplate Subassembly, Item 3

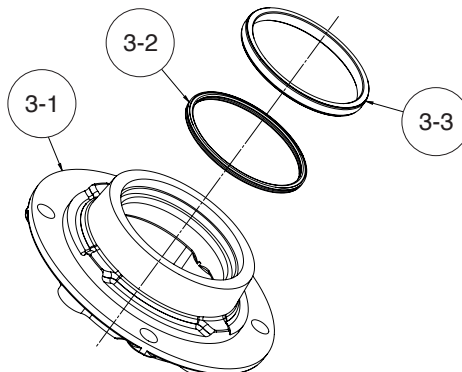

QX-1 & 2 Baseplate shown

4.6.2 Baseplate Remounting.

Step 1

Lightly lubricate 'Q'-ring (#3-2) and install in baseplate subassembly groove. Lightly lubricate 'O'-ring (#4-1) and install around baseplate subassembly pilot (#3). Slide baseplate subassembly into housing and over drive sleeve (#1-1). Fit the screws (#4-2) (Qty of 4 for QX-1 & 2) and (Qty of 8 for QX-3 thru 5) into baseplate mounting holes and tighten.

NOTES: Base Mounting Orientation.

1. QX-1 & 2 baseplate mounts with 4 screws and orientation will always be the same with the 4 mounting taps straddling centerline.
2. QX-3 thru 5 baseplate mounts with 8 screws and orientation depends on add on base options.
 - A. If not adding on any base options the 4 mounting taps in base should be straddling centerline.
 - B. If adding smaller F/FA-10 base the 4 mount taps should be on centerline.

4.7 Worm Shaft Assembly

NOTE: Sections 4.2 – 4.8 require the actuator to be removed from the mounting plate and the oil drained.

Table 4.17 Worm Shaft Parts List

ITEM NUMBER	DESCRIPTION	QTY.
2-1	WORM SHAFT	1
2-2	NEEDLE BEARING	1
2-3	THRUST BEARING	1
2-4	WASHER	1
2-5	RETAINING RING (ROUND)	1
2-6	PLATE, WORM SHAFT	1
2-7	FLAT HEAD MACHINE SCREW	5
2-8	BALL BEARING	1
2-9	KEY	1
2-10	GEAR	1
2-11	RETAINING RING	1

Figure 4.20 - Worm Shaft

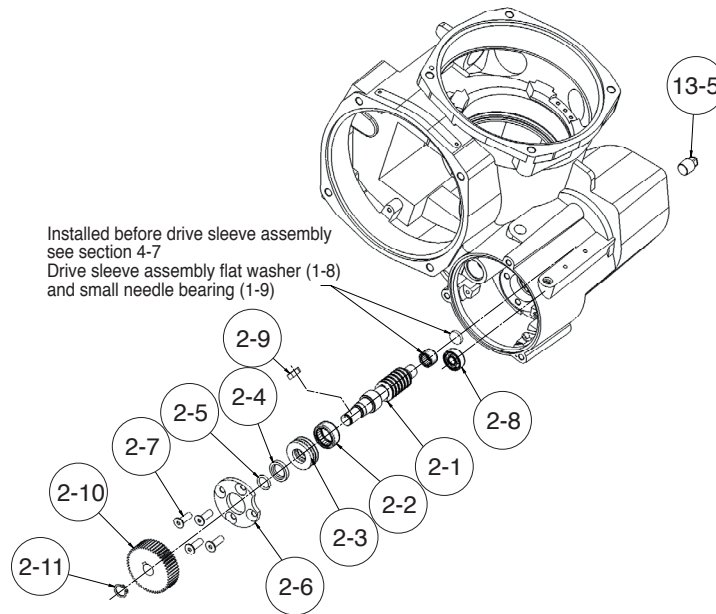

4.7.1 Worm Shaft Assembly Removal.

Step 1

⚠ WARNING: Potential to operate while dangerous mechanical parts are exposed during subassembly removal. To prevent injury, turn off all power sources to actuator before removing top-mounted handwheel assembly. Power sources may include main power or control power.

Using retaining ring pliers remove retaining ring (#2-11) and then remove gear (#2-10) and key (#2-9). Using M4 hex key (QX-1 & 2) or M6 hex key (QX-3 thru 5) remove M6 or M10 screws (#2-7) and remove plate (#2-6).

Step 2

Remove pipe plug (#13-5) from back of housing and worm shaft underneath motor. Remove base plate (#3) so drive sleeve and stops are visible (See section 4-6-1). Rotate worm shaft so the drive sleeve is in mid position. Being careful not to hit the threads of the pipe tap, hammer out the worm shaft hitting the flat washer (#1-8) that is in back of the worm shaft.

NOTE: The drive sleeve will rotate when knocking out worm shaft. Be sure that the drive sleeve is off of stops or damage to drive sleeve, stops and/or housing could accrue.

Step 3

If replacing bearings but not worm shaft remove round retaining ring (#2-5) to remove thrust bearing (#2-3) and needle bearing (#2-2) from worm shaft.

If replacing worm shaft, thrust bearing and needle bearing this step is not needed.

4.7.2 Worm Shaft Assembly Replacement.

⚠ CAUTION: Flowserve Limitorque recommends that the factory be contacted at 434-528-4400 to arrange replacement of a QX worm shaft at an authorized service center. Special tools are required for replacement.

Step 1

(Special tools required, contact factory for ordering information)

NOTE: Drive sleeve assembly must be removed before inserting washer (#1-8) and small needle bearing (#1-9).

See section 4-8-1 step 1 for drive sleeve removal and section 4-8-2 step 3 for remounting of flat washer and needle bearing.

Step 2

NOTE: Before inserting worm shaft the drive sleeve assembly must be assembled per section 4-8-2.

Insert worm shaft into housing meshing with drive sleeve and bottoming out in needle bearing installed in step 1. Note worm shaft should rotate freely with the drive sleeve and needle bearing.

Step 3

(Special tools required, contact factory for ordering information)

NOTE: Before pressing in needle bearing (#2-2) rotate worm so the drive is in mid position and off of the stops. If the drive sleeve touches stops when pressing in needle bearing damage to drive sleeve, stops and/or housing could accrue.

Lubricate needle bearing (#2-2) and place in housing and around worm shaft.

Using special tools from Flowserve lightly press needle bearing into housing until tool bottoms out. Needle bearing should be even with housing counter bore. Check that the worm shaft rotates freely and has freedom to be moved in and out.

Step 4

(Special tools required, contact factory for ordering information)

Lubricate thrust bearing (#2-3) and slide on end of worm shaft with the bigger ID bearing washer going on first. Place washer (#2-4) over end of worm shaft making sure that the chamfer on washer is facing out (Away from thrust bearing).

Using special tools from Flowserve slip on round retaining ring (#2-5). Retaining ring must engage in worm shaft round groove and fit inside the chamfer on washer (#2-4).

Step 5

Place ball bearing (#2-8) in housing bore for clutch shaft assembly. Place plate (#2-6) over end of worm shaft and align cut out notch with housing bore with bearing (#2-8). Fit the screws (#2-7) in plate holes and tighten. Place gear (#2-10) on worm shaft end and insert key (#2-9). Using retaining ring pliers secure gear and key with retaining ring (#2-11).

4.8 Drive Sleeve, Stops and Encoder Shaft Assemblies

NOTE: Sections 4.2 – 4.8 require the actuator to be removed from the mounting plate and the oil drained

Table 4.18 - Drive Sleeve, Stops, and Encoder Shaft Assembly

ITEM NUMBER	DESCRIPTION	QTY.
1-1	HOUSING	1
1-2	BUSHING	1
1-3	OIL SEAL	1
1-5	BALL BEARING (SEALED)	2
1-6	SHAFT, ENCODER	1
1-7	RETAINING RING	1
1-8	DISC	1
1-9	NEEDLE BEARING	1
1-10	INSERT	1
1-11	DRIVE SLEEVE	1
1-12	STOPS	2
1-13	O-RING	2
1-14	SOCKET HEAD CAP SCREW	2

Figure 4.21 - Drive Sleeve, Stops, and Encoder Shaft Assembly

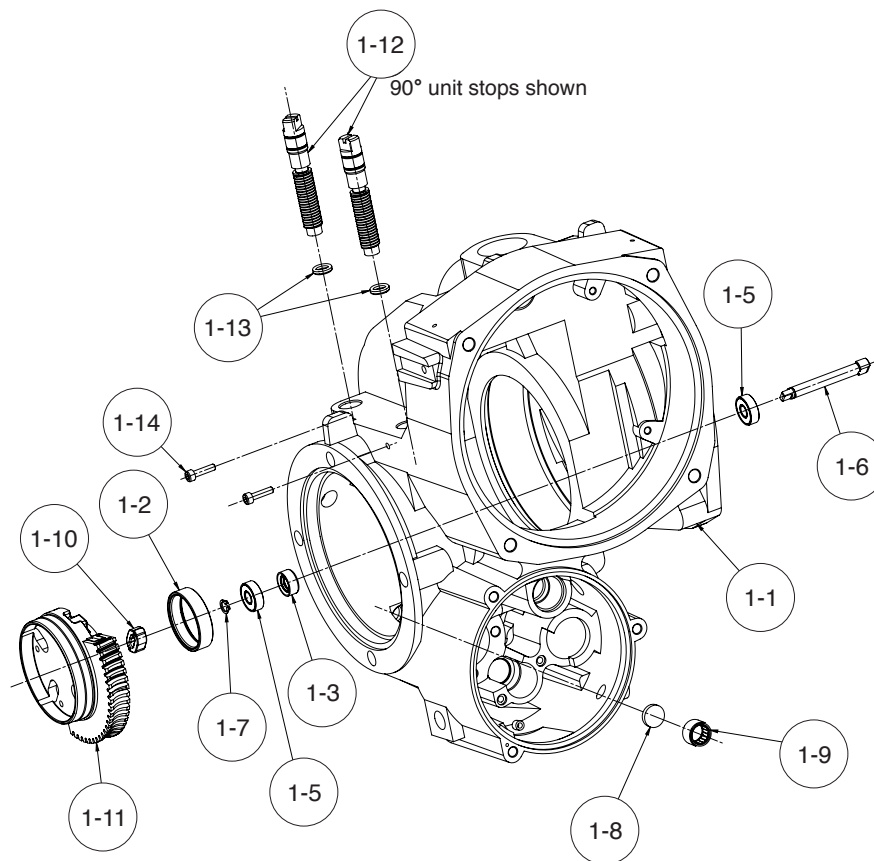

4.8.1 Drive Sleeve, Mechanical Stops, Encoder Shaft Removal.

NOTE: Baseplate (#3) must be removed to remove drive sleeve, see step 4-6-1. Washer ((#1-8) and needle bearing (#1-9) removed in section 4-7-1 step 2 when removing worm shaft.

Step 1, Drive sleeve removal.

⚠ WARNING: Potential to operate while dangerous mechanical parts are exposed during subassembly removal. To prevent injury, turn off all power sources to actuator before removing drive sleeve assembly. Power sources may include main power or control power.

Grab drive sleeve and while rotating back and forth pull out drive sleeve (#1-11). If needed remove insert (#1-10) by using inserting a screw driver down the center of the insert and prying out the insert.

Step 2, Stop removal.

Loosing screws (#1-14) using a M3 hex key. Using a flat head screw driver rotate the mechanical stops CCW to remove.

Step 3, Encoder shaft removal.

NOTE: The encoder must be removed before this step. (See Section 5 - Encoder Assemblies)

Using retaining ring pliers remove retaining ring (#1-7). Grab the encoder shaft (#1-6) from the terminal block side of the housing and pull out. Remove ball bearings (#1-5).

Table 4.19 - Multi-turn Encoder Shaft Subassembly (Item 1-6)

ITEM NUMBER	DESCRIPTION	QTY.
1	ENCODER SHAFT	1
2	PINION	1
3	ROLL PIN	1

Figure 4.22 - Multi-turn Encoder Shaft Subassembly (Item 1-6)

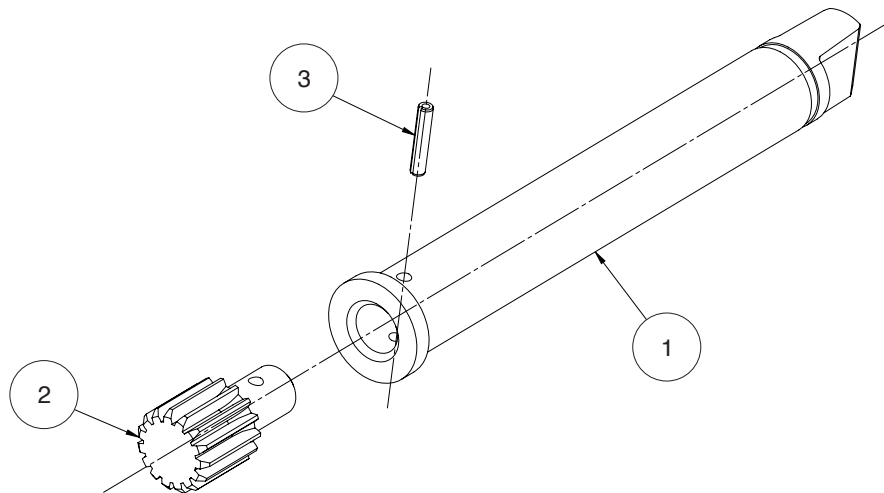

Step 4 – Encoder shaft seal.

If replacing encoder shaft seal (#1-3) the seal must be pried out using small screw driver.

NOTE: Be careful not to damage the seal bore of the unit housing (#1-1). Seal will not seal correctly if housing seal bore is damaged.

NOTE: Bushing (#1-2) is pressed on to housing. If bushing and/or housing is damaged a subassembly of the housing with the bushing will have to be ordered from the factory.

4.8.2 Drive Sleeve, Mechanical Stops and Encoder Shaft Assembly Remounting.

Step 1, Encoder shaft seal.

(Special tool required, contact factory for ordering information)

Using tool from factory press oil seal (#1-3) into housing making sure that the open end of the seal is towards the base of the unit. If some of the seal is torn, remove the excess.

Step 2, Encoder shaft assembly.

Insert the two ball bearings (#1-5), one on the encoder side and one on the unit base side. Slide the encoder shaft (#1-6) through from the encoder side and using retaining ring pliers place retaining ring (#1-7) on base side of encoder shaft. Ensure retaining ring is seated correctly in encoder shaft groove.

Step 3, Flat washer and small needle bearing.

(Special tools required, contact factory for ordering information)

NOTE: drive sleeve assembly must be removed before inserting washer (#1-8) and small needle bearing (#1-9).

Place flat washer (#1-8) in bottom of housing worm shaft bore making sure the washer is flat in bottom of housing bore. Note that this washer is needed if worm shaft is to be removed at any time in the future.

Lubricate needle bearing (#1-9) and using special tools from Flowserve lightly press or hammer needle bearing into housing until seated.

Step 4, Mechanical Stop assembly.

If needed replace 'O'-ring (#1-13) on stop (#1-12). (Special tool can be order from factory for installing 'O'-ring, contact factory for ordering information).

Insert stops into housing and using a flat head screw driver turning in stop CW to about midpoint of the two grooves on the stop.

NOTE: The two grooves on the stop is approximate min and max positions of stop travel by aligning grooves with housing face. If stop is positioned out too far oil could leak by the mechanical stop 'O'-ring. Stop positions will have to be reset after mounting unit to valve.

Figure 4.23 - Stop Groove View

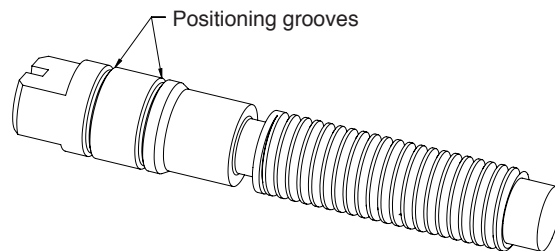

Step 5, Drive sleeve remounting.

If removed place new encoder insert (#1-10) into drive sleeve (#1-11) slot. Place drive sleeve in to housing aligning drive sleeve with bushing (#1-2) and the insert with the encoder shaft flats. Rotate drive sleeve to each end of travel to make sure that it turns smoothly. Leave loose for installing the worm shaft.

4.9 Optional Baseplate Assembly, F/FA-05 & -07 QX-1 & 2, F/FA-10 QX-3 thru 5.

4.9.1– Optional Baseplate Removal.

Table 4.20 - Optional Baseplate Removal

ITEM NUMBER	DESCRIPTION	QTY.
16-2	BASEPLATE	1
16-3	SOCKET HEAD CAP SCREWS	4

Figure 4.24 - F/FA-05 / 07, QX-1 & 2 or F/FA-10, QX-3 thru 5 Optional Baseplate

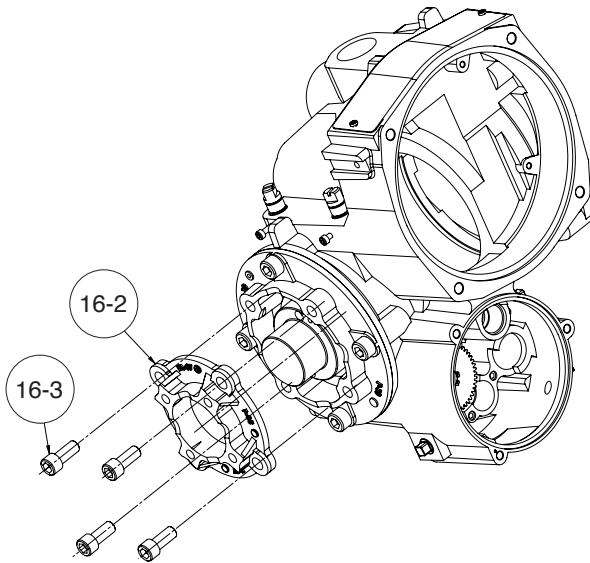

Step 1

QX-1 & 2, MSS FA-05 or -07 baseplate. Using a 5/16" hex key For MSS baseplate, remove the 3/8-16 screws (#4-2) and remove baseplate (#3).

QX-1 & 2, ISO F-05 or -07 baseplate. Using a M8 hex key For ISO baseplate, remove the M10 screws (#4-2) and remove baseplate (#3).

QX-3, 4 & 5, MSS FA-10 baseplate. Using a 1/2" hex key For MSS baseplate, remove the 5/8-11 screws (#4-2) and remove baseplate (#3).

QX-3, 4 & 5, ISO F-10 baseplate. Using a M14 hex key For ISO baseplate, remove the M16 screws (#4-2) and remove baseplate (#3).

4.9.2 – Optional Baseplate Remounting.

NOTE: For small baseplate the torque nut must be mounted to drive sleeve before mounting baseplate. See section 4-11-1.

Place small baseplate on large baseplate aligning pilot. Place screws in baseplate holes and tighten.

4.10 Torque Nut.

Table 4.21 - Torque nut, F/FA-10, QX-1 & 2 and F/FA-12 and -14, QX-1 thru 5

ITEM NUMBER	DESCRIPTION	QTY.
13-6	TORQUE NUT	1
13-7	SCO HEAD CAP SCREW	1

Figure 4.25 - Torque nut, F/FA-10, QX-1 & 2 and F/FA-12 and -14, QX-1 thru 5

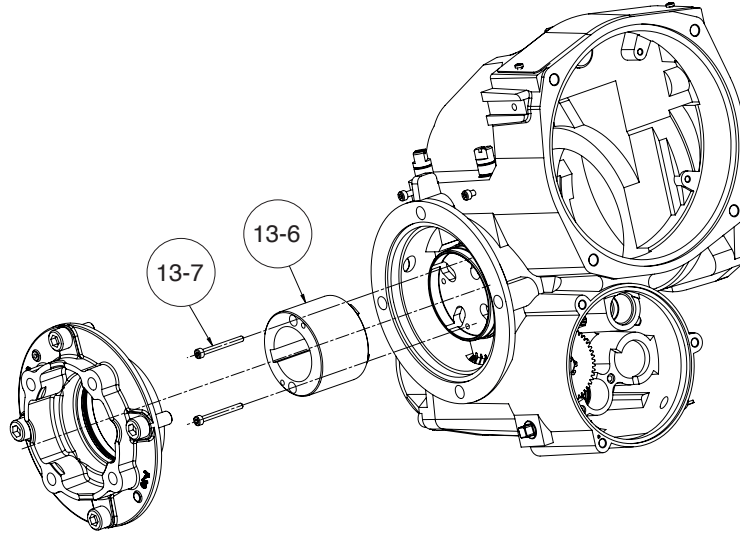
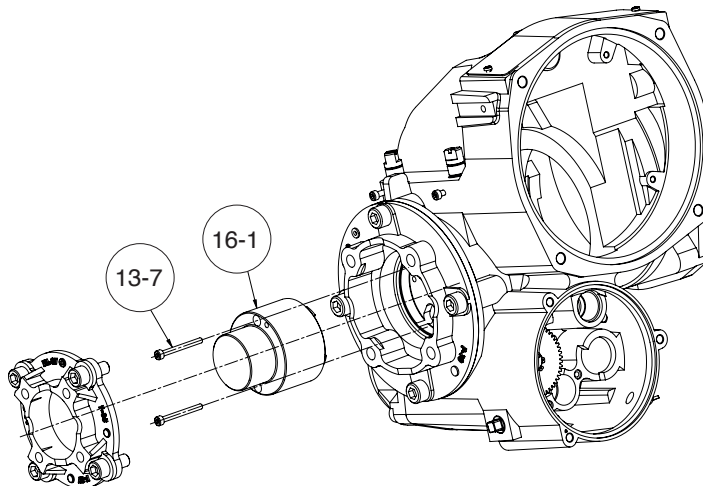

Table 4.22 - Torque nut F/FA-05 and -07 QX-1 & 2 and F/FA-10, QX-1 thru 5

ITEM NUMBER	DESCRIPTION	QTY.
13-7	SOCKET HEAD CAP SCREW	1
16-7	TORQUE NUT	1

Figure 4.26 - Torque nut, F/FA-05 and -07, QX-1 & 2 and F/FA-10, QX-1 thru 5



4.10.1 Optional Small Baseplate Removal.

Step 1

QX-1 & 2, F/FA-10 and QX-3 thru 5 F/FA-12 and -14. Using a M3 hex key for QX-1 & 2 or M5 hex key for QX-3, 4 & 5, remove the M4 or M6 screws (#13-7) and remove torque nut (#13-6).

QX-1 & 2, F/FA-05 or -07, QX-3 thru 5 F/FA-10.

Remove small baseplate per Section 4-6-4. Using a M3 hex key, QX-1 & 2 or M5 hex key for QX-3, 4 & 5, remove the M4 or M6 screws (#13-7) and remove torque nut (#16-7).

4.10.2 Optional Small Baseplate Remounting.

Step 1

NOTE: Torque nut may be mounted in 1 of 4 positions (every 90°) on QX-1 & 2 and 1 of 8 positions (every 45°) on the QX-3 thru 5. Make sure the torque nut is in the position needed.

Slide torque into drive sleeve aligning pilot and lugs, Place screws in torque nut holes and tighten. Remount baseplate.

4.11 Optional Thrust Base Assembly QX-1 & 2.

Table 4.23 - Optional Thrust Base Assembly

ITEM NUMBER	DESCRIPTION	QTY.
16-10	TORQUE NUT	1
16-11	BUSHING	1
16-12	O'-RING	1
16-13	O'-RING	1
16-14	ADAPTER PLATE	1
16-15	SOCKET HEAD CAP SCREWS	4
16-16	SPACER, PILOT, ISO ONLY	1
16-17	THRUST BASE ASSEMBLY	1

Figure 4.27 - Optional Thrust Base Assembly QXM Only

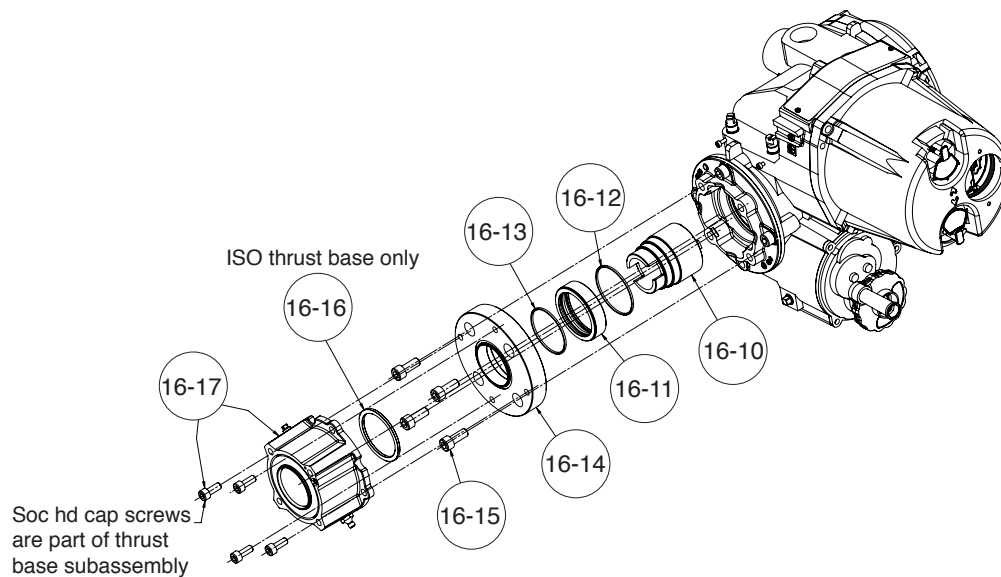

4.11.1 Optional Thrust Base Assembly Removal.

Step 1

Remove the four (4) screws (#) and remove the thrust base subassembly (#16-17) by sliding the base down. If base is ISO remove the spacer (pilot) (#16-16).

Step 2

Remove the four (4) screws (# 16-15) and remove the adapter plate (#16-14) and torque nut (#16-10). Item (#16-11) bushing is pressed into adapter plate and cannot be removed. The torque nut is held in place by the unit drive sleeve and the bushing (#16-11).

Table 4.24 Optional Thrust Base Subassembly

ITEM NUMBER	DESCRIPTION	QTY.
10-1	HOUSING, THRUST BASE	1
10-2	PILOT, THRUST BASE	1
10-3	THRUST NUT	1
10-6	SOCKET HEAD CAP SCREWS	1
10-7	FLAT WASHER	1
10-8	RELIEF FITTING	1
10-10	SOCKET HEAD CAP SCREWS	4
10-11	GREASE FITTING	1
10-12	NEEDLE BEARING	2
10-13	THRUST RACE	2
10-14	QUAD RING	1
10-15	O'-RING	1
10-16	QUAD RING	1

Figure 4.28 - Optional Thrust Base Subassembly

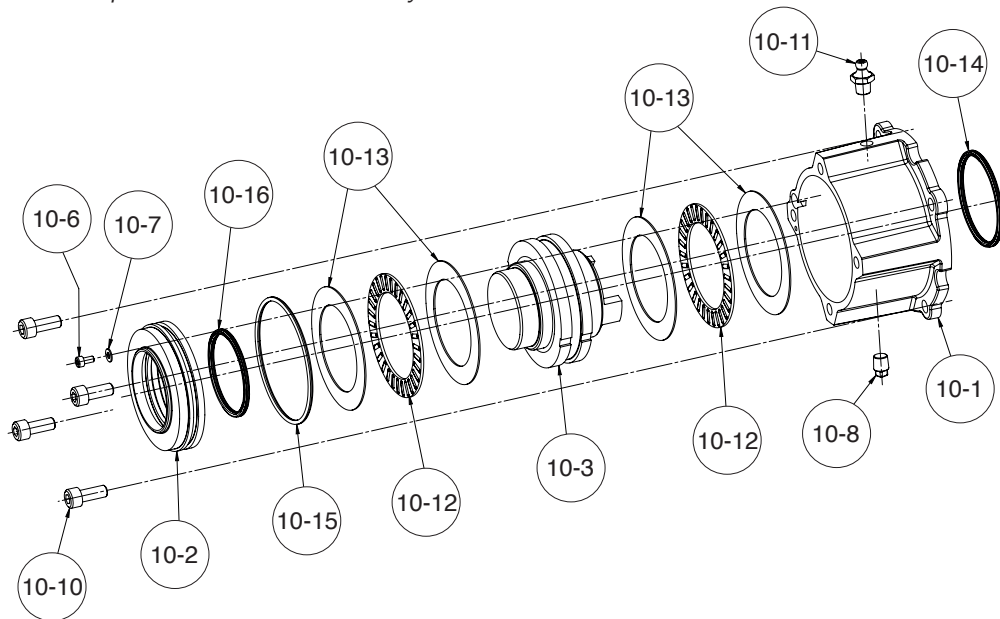

4.11.2 Thrust Base Remounting.

Step 1

Place QX torque nut (#16-10) into unit drive sleeve (#1-11) aligning nut lugs to drive sleeve slots.

Step 2

Lightly lubricate 'O'-rings (#16-12) and (#16-13) and insert into bushing (#16-11) that is pressed into adapter plate (#16-14). Slide adapter plate and bushing over end of torque nut and aligning to unit baseplate. Insert screws (#16-15) into adapter plate holes and tighten.

Step 3

Align thrust base subassembly nut lugs (#10-3) with QX torque nut (#16-10) slots and slide thrust base on to QX unit baseplate aligning pilots. Note; For ISO thrust base pilot spacer (#16-16) must be used to align thrust base to QX baseplate. Insert screws (#10-10) into thrust base holes and tighten.

5 Encoder Assemblies

5.1 Encoder 90 Degree Unit Removal. QX-1 thru 5

Table 5.1 - 90° Encoder Assembly

ITEM NUMBER	DESCRIPTION	QTY.
14-1	ENCODER ASSEMBLY	1
14-2	SOCKET HEAD CAP SCREWS	3

Figure 5.1 90° Encoder Assembly

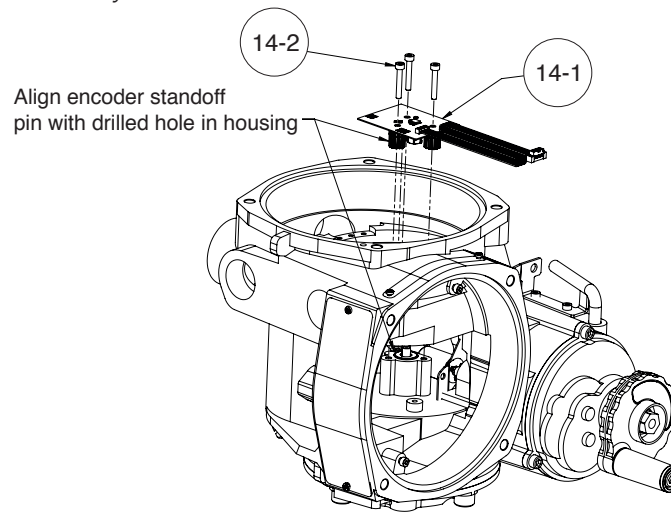

5.1.1 – 90 Degree Encoder Removal.

Step 1

NOTE: The terminal block must be removed before removing the encoder. See section 6.4 for terminal block removal.

Disconnect the encoder ribbon cable connector from the Motor controller board, See Section 7.1 for connector placement. Using M3 Hex key remove the three screws (#14-2) that mount the encoder. Gently pull the encoder up and out of the housing thru the terminal block bore.

Table 5.2 - Encoder Subassembly, Item 14-1

ITEM NUMBER	DESCRIPTION	QTY.
1	ENCODER BOARD	1
2	ROTOR	1
3	STANDOFF	1
4	SELF TAP OVAL HEAD SCREWS	4

Figure 5.2 - Encoder To Subassembly, Item 14-1

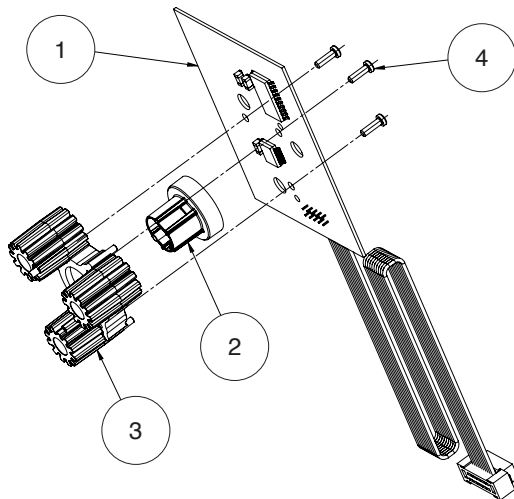

5.1.2 90 Degree Encoder Remounting

Step 1

Slide the encoder assembly into housing and down over encoder shaft (#1-6) aligning the rotor (#2) of the encoder to the encoder shaft OD, flats, encoder standoff ID to encoder top ball bearing (#1-5) and encoder standoff pin to housing alignment hole (See Figure 5.3 - Encoder To Unit Assembly View).

NOTE: The encoder rotor can only be mated to the encoder shaft in one position. The encoder shaft has 3 flats that must align correctly to the encoder rotor ID and ribs.

Figure 5.3 - Encoder To Unit Assembly View

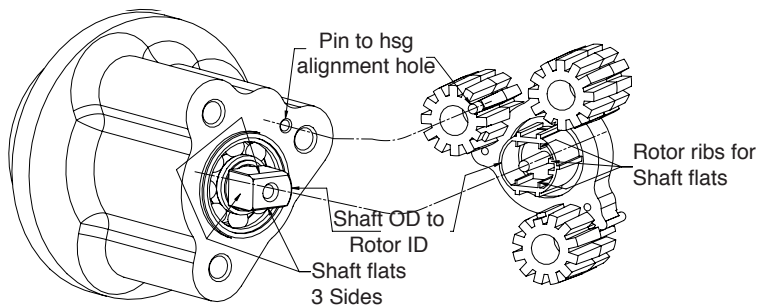

Step 2

Install the three M4 screws thru encoder and standoff assembly (#14-2) and tighten. Take note not to over tighten.

Step 3

Reconnect encoder ribbon cable to motor controller board. (See Section 7.1 for connector position on motor control board)

5.2 Multi Turn Encoder. QXM-1 thru 5, all RPMs

Table - 5.3 Multi-Turn Encoder Assembly

ITEM NUMBER	DESCRIPTION (6.5 TURN)	DESCRIPTION (20 TURN)	QTY. (QX-1 &2)	QTY. (QX-3 THRU 5)
17-1	DOWEL PIN	DOWEL PIN	1	1
17-2	6.5 TURN SPUR GEAR ASSY	SPUR GEAR ASSY	1	1
17-3	SOC HEAD CAP SCREW	SOC HEAD CAP SCREW	2	2
17-4	SPACER	SPACER	2	NA
17-5	SOCKET HEAD CAP SCREWS	SOCKET HEAD CAP SCREWS	2	2
17-6	SOCKET HEAD CAP SCREWS	SOCKET HEAD CAP SCREWS	3	3

Figure 5.4 - Multi-turn Encoder Assembly

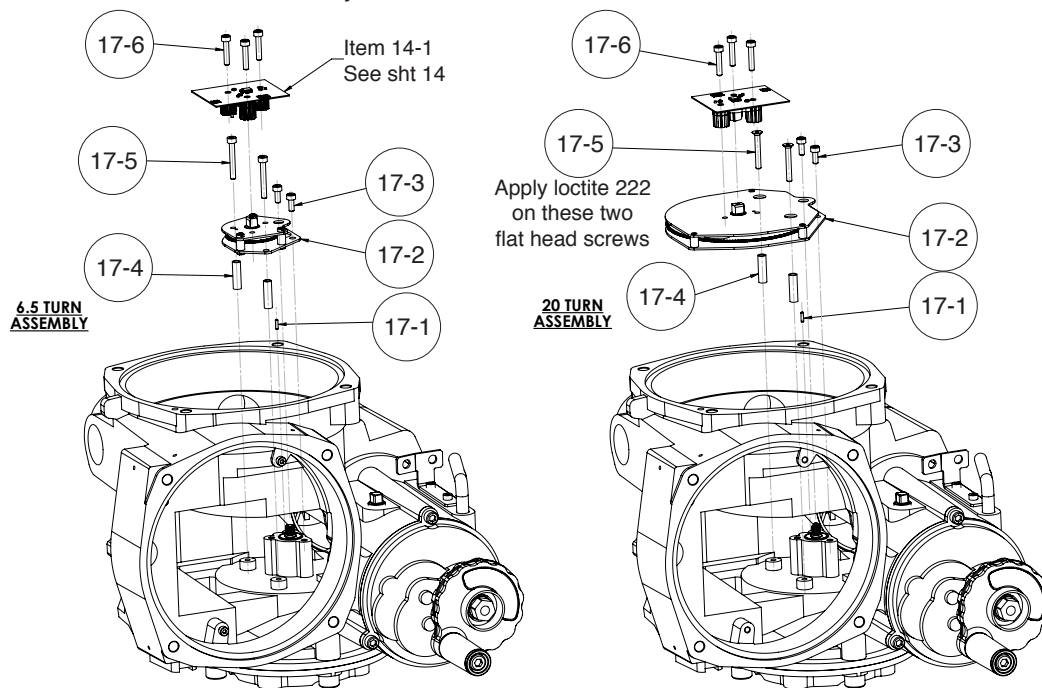

5.2.1 Multi Turn Encoder Removal

Step 1

NOTE: The terminal block and power controls must be removed before removing the encoder. See section 6.4 for terminal block and controls removal.

Disconnect the encoder ribbon cable connector from the Motor controller board, See section 6 for connector placement. Using M3 Hex key remove the three screws (#17-6) that mount the encoder. Gently pull the encoder up and out of the housing thru the terminal block bore.

Step 2

Using M3 Hex key (QX-1 & 2) or M2.5 Hex key (QX-3 thru 5) remove the two screws (#17-5) that mount the encoder spur gear subassembly to the two housing pads.

NOTE: For the 20 turn encoder assembly the slots in the big gear must be aligned with the top and bottom plate to access screws (#17-5). To do this the encoder shaft and/or drive sleeve must be rotated to the correct position aligning slots. See Figure 5.4 for orientation view.

Using M3 Hex key remove the two screws (#17-3) that mount the encoder spur gear subassembly to the housing encoder pad. Gently pull the spur gear subassembly up and over encoder shaft and pinion and out the controls area bore in housing.

QX-1 and 2 remove the two spacers (#17-4) (not used in QX-3 thru 5). The dowel pin (#17-1) is press into the housing.

Table 5.4 - 6.5-Turn Spur Gear Subassembly (Item 17-2)

ITEM NUMBER	DESCRIPTION	QTY.
1	TOP PLATE	1
2	SHAFT, ENCODER	1
3	GEAR	1
4	ROLL PIN	1
5	BOTTOM PLATE	1
6	STANDOFF	3
7	COMBO HEAD SCREW	6

Figure 5.5 - 6.5-Turn Spur Gear Subassembly (Item 17-2)

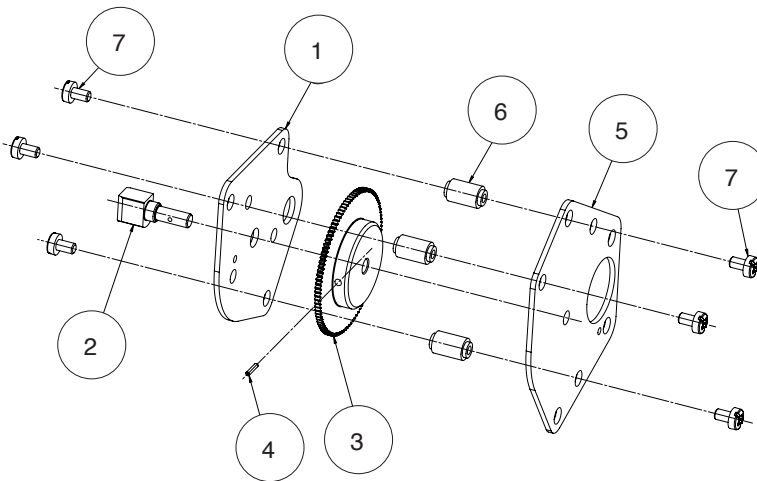
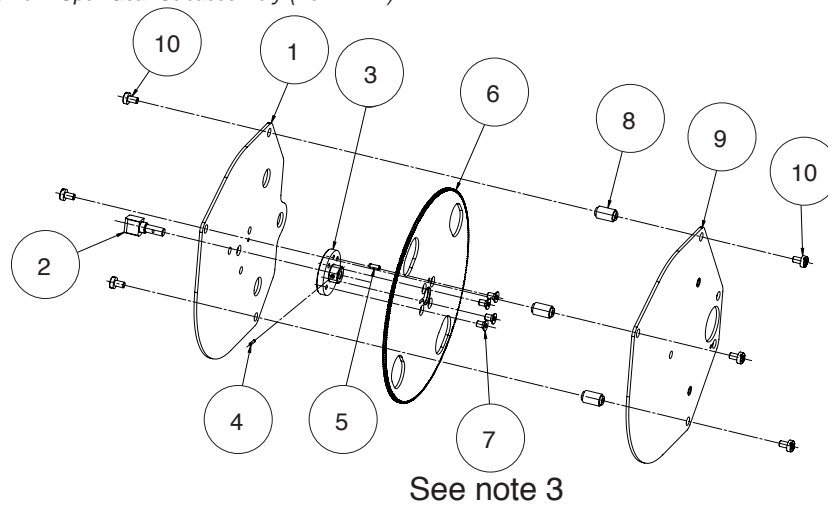

Table 5.5 - 20-Turn Spur Gear Subassembly (Item 17-2.)

Pc NUMBER	DESCRIPTION	QTY.
1	TOP PLATE	1
2	SHAFT, ENCODER	1
3	HUB, GEAR	1
4	ROLL PIN	1
5	DOWEL PIN	1
6	GEAR	1
7	FLAT HEAD SCREW	4
8	STANDOFF	3
9	BOTTOM PLATE	1
10	COMBO HEAD SCREW	6

Figure 5.6 - 20-Turn Spur Gear Subassembly (Item 17-2)



5.2.2 Multi Turn Encoder Remounting

Step 1

Slide the encoder spur assembly (#17-2) into housing thru housing controls area bore and down over the multi turn encoder shaft pinion. Align spur assembly bottom plate to top encoder ball bearing (#1-5), the dowel pin (#17-1) while also aligning the spur assembly big gear to the encoder shaft pinion.

NOTE: for the 20 turn assembly the big spur gear slots must be aligned with the holes in the top and bottom plates to insert the two (#17-3) screws. Figure 5.7 for orientation view.

Insert the two screws (#17-3) and tighten.

Figure 5.7 - 20-Turn Gear Slot Orientation View

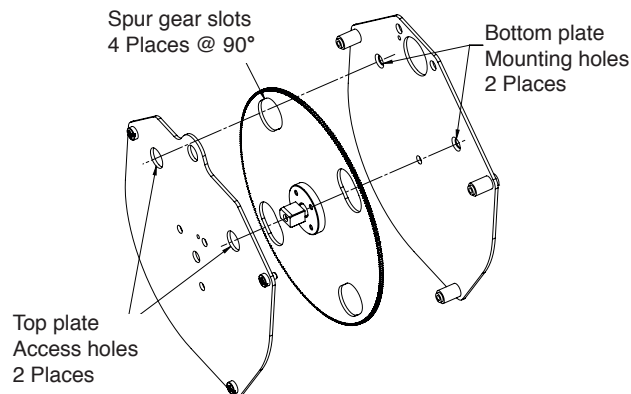

Step 2

Place spacers (#17-4) (QX-1 & 2 only) in place in-between the spur assembly bottom plate and the housing lower pads, Note that this step can be done before step 1. Insert screws (#17-5) and tighten.

Step 3

Slide the encoder assembly into housing and down over encoder shaft (#2) on multi turn spur assembly aligning the rotor (#2) of the encoder to the encoder shaft OD, flats and encoder standoff pin to the top spur assembly alignment hole (See Figure 5.3) for reference.

Note: The encoder rotor can only be mated to the encoder shaft in one position. The encoder shaft has 3 flats that must align correctly to the encoder rotor ID and ribs. See Figure 5.3 for reference.

Step 4

Install the three M4 screws thru encoder and standoff assembly (#17-6) and tighten. Take note not to over tighten.

Step 5

Reconnect encoder ribbon cable to motor controller board. (See section 6 for connector position on motor control board).

6 Electronic Assemblies

6.1 Terminal Cover

Table 6.1 - Terminal Cover Assembly

ITEM NUMBER	DESCRIPTION	QTY.
15-5	TERMINAL COVER SUBASSEMBLY	1
15-6	SOCKET HEAD CAP SCREWS	3

Figure 6.1 - Terminal Cover Assembly

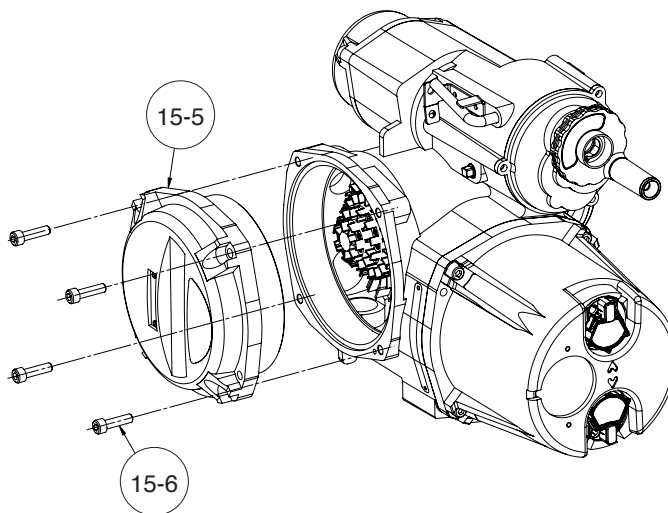

6.1.1 Terminal Cover Removal

- ⚠ **WARNING:** Hazardous Voltage! Turn off all power sources to actuator before removing control module assembly. Power sources may include main power or control power.
- ⚠ **CAUTION:** Potential to cause electrostatic damage to electronic components. Before handling electronic components, ensure that you are discharged of static electricity by briefly touching a grounded metal object.

Step 1

Using a M6 hex key, remove the four M8 screws (#15-6) that mount the Terminal cover subassembly and remove cover (#15-5).

Table 6.2 - Terminal Cover Subassembly

ITEM NUMBER	DESCRIPTION	QTY.
8-12	TERMINAL COVER	1
8-13	O'-RING	1
8-27	LABEL, TERMINAL BLOCK	1
8-28	HOOK	1
8-29	LOOP	1

Figure 6.2 - Terminal Cover Subassembly

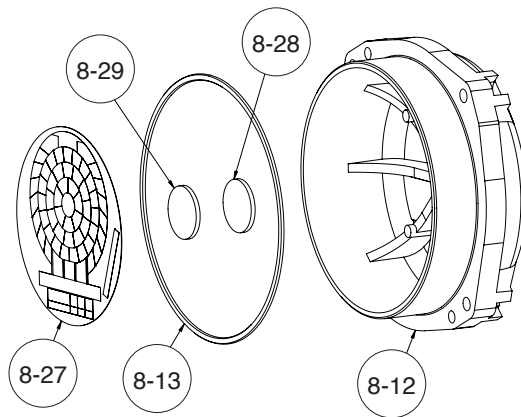

6.1.2 Terminal Cover Remounting

Step 1

Lightly lubricate 'O'-ring (#8-13) and install around terminal cover spigot/pilot (#8-12). Slide terminal cover spigot/pilot into the unit housing.

Step 2

Fit the 4 screws (#15-6) into terminal cover subassembly mounting holes and tighten to torque in section 2.

6.2 Controls Cover

Table 6.3 - Controls Cover Assembly

ITEM NUMBER	DESCRIPTION	QTY.
15-3	CONTROLS COVER SUBASSEMBLY	1
15-6	SOCKET HEAD CAP SCREWS	3

Figure 6.3 - Controls Cover Assembly

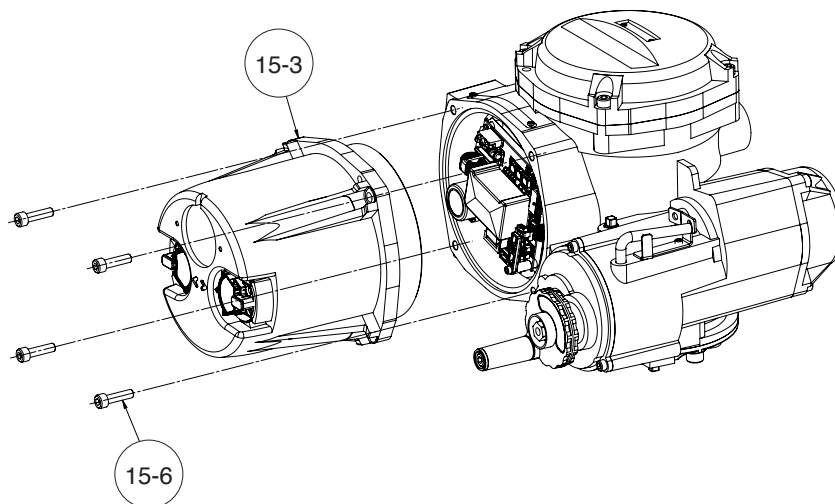

6.2.1 Controls Cover Removal

Step 1

Using a M6 hex key, remove the four M8 screws (#15-6) that mount the Controls cover subassembly and remove cover (#15-3).

NOTE: When removing cover take care not to pull on cables that connect to the controls cover main board.

Table 6.4 - Controls Cover Subassembly

ITEM NUMBER	DESCRIPTION	QTY.
1-49	SHIELD, MAIN BOARD	1
7-2	O'-RING	1
7-3	BLACK KNOB	1
7-4	RED KNOB	1
7-6	SELF TAPPING SCREW	2
7-7	BLACK KNOB CAP	1
7-12	TORSION SPRING	1
7-14	RED KNOB CAP	1
7-17	CONTROLS COVER	1
7-18	WINDOW	1
7-19	O'-RING RETAINER	1
7-20	RETAINING RING	1
7-21	O'-RING	1
7-44	PAN HEAD MACHINE SCREW	4
8-24	PC BOARD, MAIN	1

Figure 6.4 - Controls Cover Subassembly

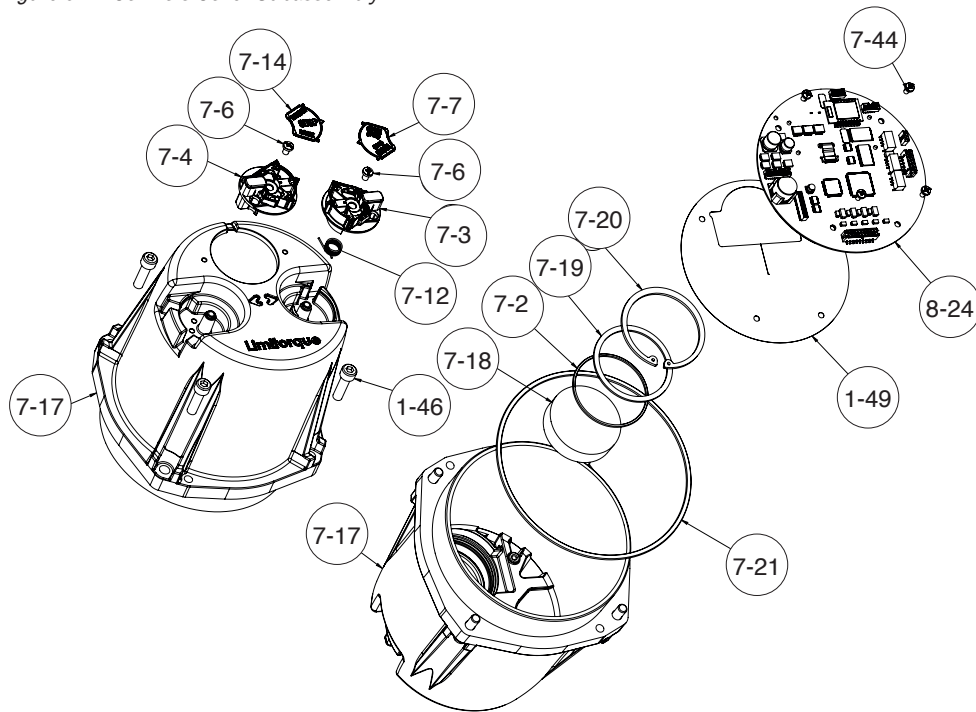

6.2.2 Controls Cover Subassembly Remounting

Step 1

Lightly lubricate 'O'-ring (#7-21) and install around controls cover spigot/pilot (#7-17). Connect all wiring (See section 7 for wiring connection locations). Slide controls cover spigot/pilot into the unit housing insuring not to pinch wiring.

Step 2

Fit the 4 screws (#15-6) into controls cover mounting holes and tighten to torque in section 2.

6.3 Control Modules

Table 6.5 - Control Module Assembly

ITEM NUMBER	DESCRIPTION	QTY.
14-8	CONTROLS SUBASSEMBLY	1
14-9	SOCKET HEAD CAP SCREWS	3
14-11	BRACKET, CONNECTOR RETAINER	1
14-12	SOCKET HEAD CAP SCREWS	1

Figure 6.5 - Control Module Assembly

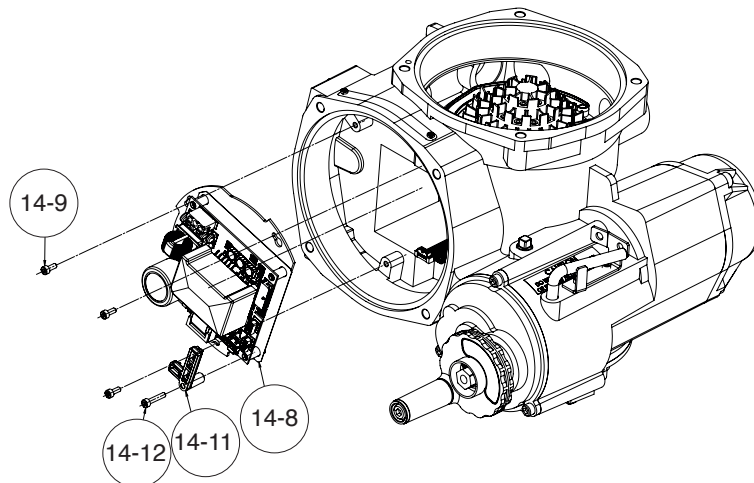

6.3.1 Control Module Removal

Step 1

Using a M3 hex key remove screw (# 14-12) and retainer (#14-11). Disconnect all wiring harnesses.

Step 2

Using a M3 hex key, loosen the three M4 mounting screws (#14-9) that mount the Control module subassembly. Slightly rotate the complete control module subassembly in a counterclockwise (CCW) direction until the keyholes slots in the control module chassis plate (#1-1) allow the head of the screws to pass thru and remove controls subassembly.

6.3.2 Control Module Subassemblies

Table 6.6 - Low Voltage (Less than 250 VAC) Control Module Subassembly

ITEM NUMBER	DESCRIPTION	QTY.
1-1	CHASSIS PLATE	1
1-2	MOTOR CONTROLLER BOARD	1
1-7	SHIELD	1
1-8	PAN HEAD CAP SCREW	4
1-9	COVER, IRAM	1
1-10	RIBBON CABLE	1

Figure 6.6 - Low Voltage (Less than 250 VAC) Control Module Subassembly

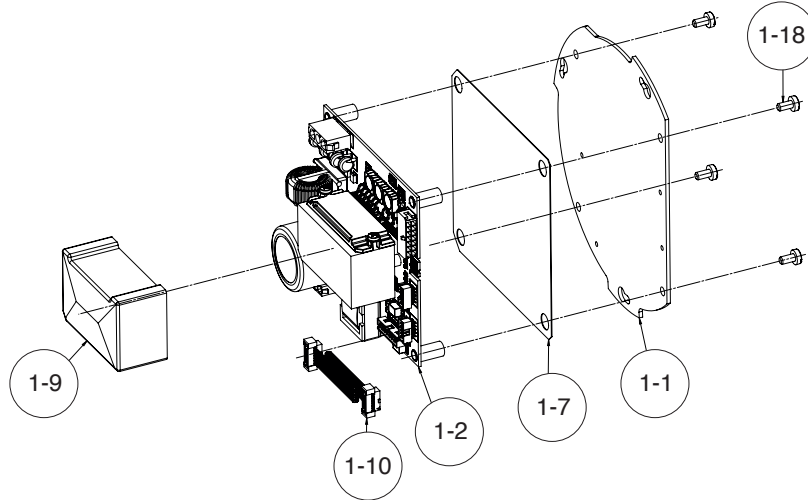

Table 6.7 - High Voltage (Greater than 250 VAC) Control Module Subassembly

ITEM NUMBER	DESCRIPTION	QTY.
1	CHASSIS PLATE	1
2	RUBBER PAD, TOROID	2
3	TRANSFORMER, TOROID	1
4	MOUNTING PLATE, TOROID	1
5	FLAT WASHER	2
6	HEX HEAD CAP SCREW	1
7	HEX NUT	1
8	MOTOR CONTROLLER BOARD	1
13	SPACER	4
14	SHIELD	1
15	PAN HEAD CAP SCREW	4
16	COVER, IRAM	1
17	RIBBON CABLE	1

Figure 6.7 - High Voltage (Greater than 250 VAC) Control Module Subassembly

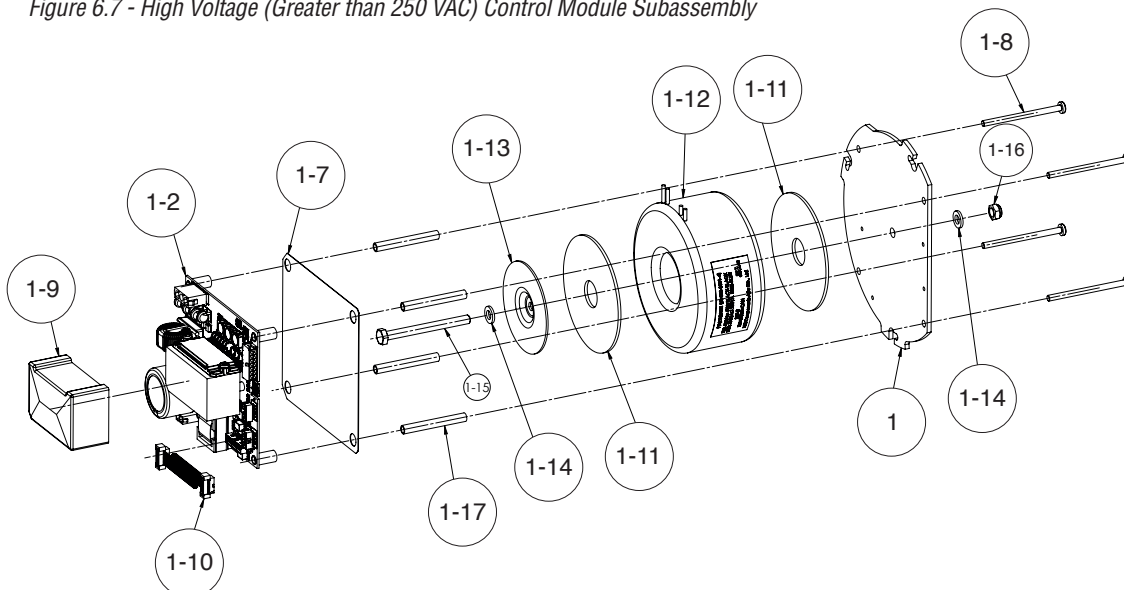
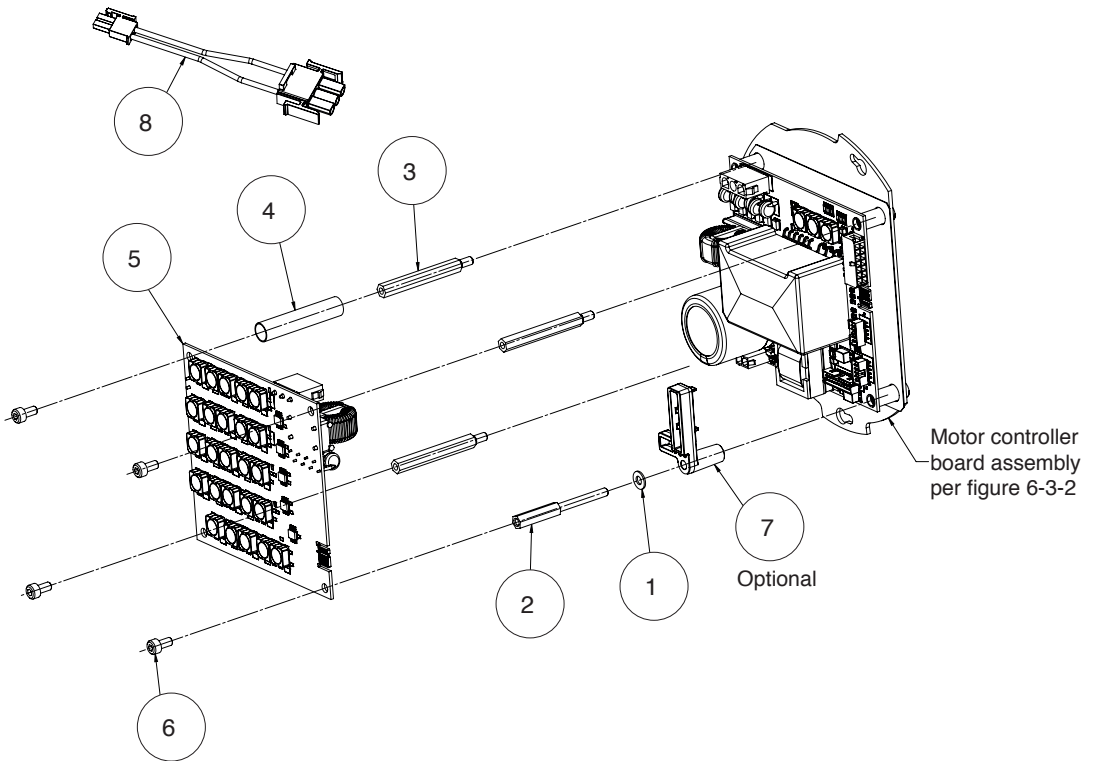

Table 6.8 - DCV Control Module Subassembly

ITEM NUMBER	DESCRIPTION	QTY.
1	FLAT WASHER	1
2	HEX STANDOFF, SHORT	1
3	HEX STANDOFF, LONG	3
4	PVC TUBE	1
5	DC BOARD	1
6	SOCKET HD CAP SCREWS	1
7	BRACKET, CONNECTOR RETAINER (OPTIONAL)	1
8	WIRING HARNESS	1

Figure 6.8 - DCV Control Module Subassembly



NOTE: If optional bracket (Item 7) is not used the flat washer (Item 1) and short standoff (Item 2) will be replaced with the long spacer (Item 3).

6.3.3 Control Module Remounting

Step 1

Position the controls module subassembly over the three mounting screw heads (#14-9). Rotate the subassembly in a clockwise (CW) direction until all three screws are seated in the keyhole slots.

(The keyhole slots in the chassis plate (#1 or 1-1) are spaced in such a way that the control module subassembly will mount in only one position).

Step 2

Tighten the three screws (#14-9) with a 3mm hex key.

Step 3

Connect wiring (See section 7 for wiring connection). Place retainer (#14-11 or 7) (Optional) on control module ensuring the long tang sits in-between the Iram heat sink cover (#1-9 or 16) and connector on control module

For AC controls Insert screw (#14-12) in to retainer hole (#14-11) and tighten. For DC controls Insert flat washer (#1) and standoff (#2) in to retainer hole (#14-11) and tighten. . (See Figure 6.9).

Figure 6.9 - Bracket Connector Retainer Assembly

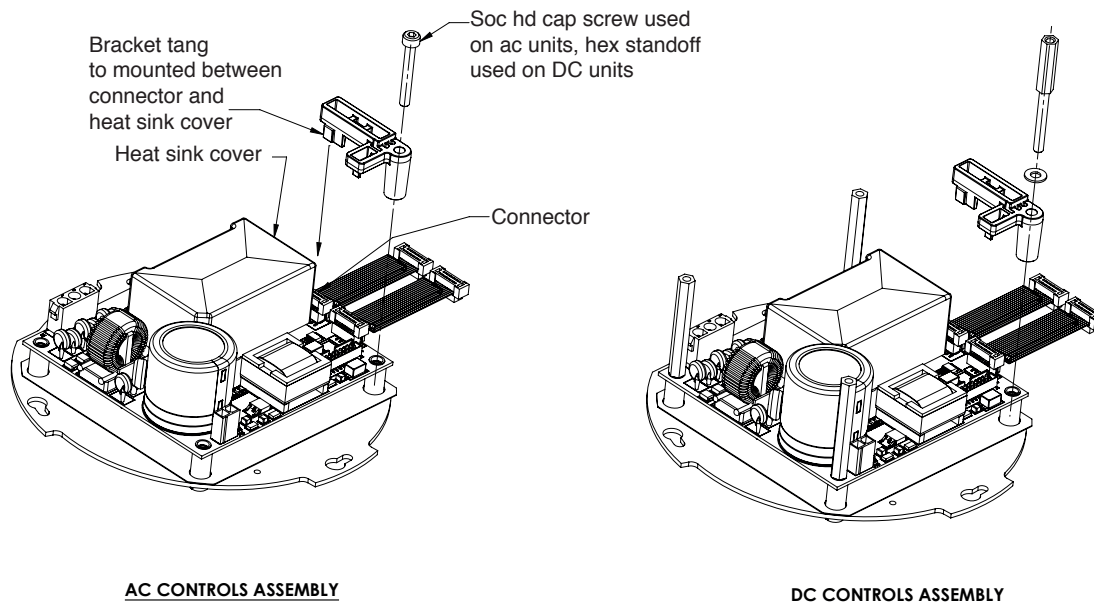

6.4 Terminal Block

Table 6.9 Terminal Block Assembly

ITEM NUMBER	DESCRIPTION	QTY.
14-3	O'-RING	1
14-4	TERMINAL BLOCK SUBASSEMBLY	1
14-5	RETAINING RING	1

Figure 6.10 - Terminal Block Assembly

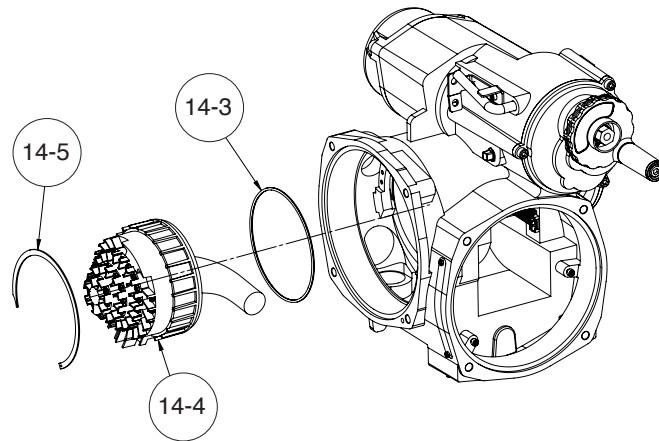

6.4.1 Terminal Block Shield

Figure 6.11 - Terminal Block Shield

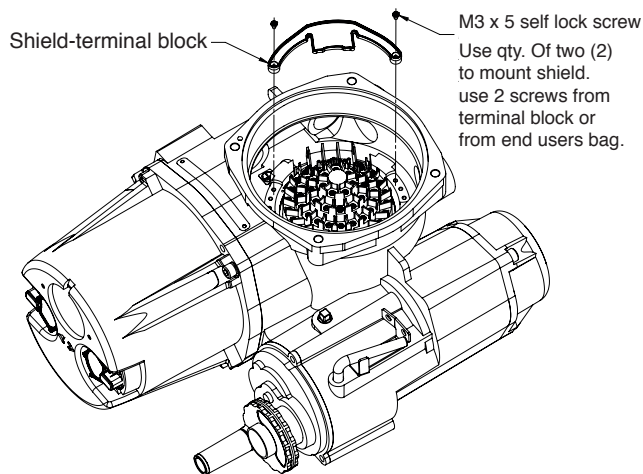

6.4.2 Terminal Block Removal

Step 1

Remove terminal block cover.

Step 2

Use Qty of 2 screws from terminal block or from end users bag to attach shield.

Step 3

Remount terminal block cover.

6-5 Mounting of Standard and Optional Controls

6.5.1 Installation

NOTE: RESTRICTIONS ON OPTION BOARD COMBINATIONS: Only one of the following can be on any unit: Modbus - DDC, Profibus PA, Profibus DP, FOUNDATION Fieldbus, DeviceNet.

A shield must be installed on the last board fitting between the last option board and the power board. See Figure 6.14 for illustration.

A maximum of four option boards can be used per unit, barring other restrictions. A four option board stack requires four (4) M4x70 pan head screws.

A single option board stack requires four (4) M4x25 pan head screws.

STEP 1 – Standard 2A, (4) “OS” contacts (LCS/Main Board)

Connect to the control cover using (4) M4x8 pan head screws.

From the terminal block, connect 12-pin plug (Cable J1) to socket J5 on the main board.

STEP 2 – Option “OA”, 4-5A “R” contacts and (1) 5A MR (monitor relay); Digital Output board connection

Connect to the control cover using four (4) M4x25 pan head screws.

Ensure that jumper on the DO board is located in the 1-2 position. Connect 12-to-22 pin adapter to Cable J1 (12-pin plug). Connect to the 22-pin socket J3 on DigOut board

NOTE: This will disable the digital relays on the main board. A keycode must be entered to restore them. Please contact factory at 434-528-4400 for the keycode.

A shield is required to be installed between the digital output board and any adjacent boards.

STEP 3 - Option “OB”, 4-5A “R” contacts and (1) 2A MR (monitor relay); Digital Output board connection and 2 – 2A “S” contacts

Connect to the control cover using four (4) M4x25 pan head screws.

Ensure that the jumper is located in the 3-4 position. Connect Cable J1 (12-pin) to socket J5 (12-pin) on the main board. Connect cable J5 (22-pin) to socket J3 on DigOut board.

STEP 4 - Option “OC”, 8-5A “R” contacts and (1) 5A MR (monitor relay); 2 Digital Output boards connection

Connect to the control cover using four (4) M4x40 pan head screws.

Ensure that the jumper on DigOut board 1 is in the 1-2 position and the jumper on DigOut board 2 is in the 3-4 position. Connect the 12-22 pin adapter to Cable J1 (12-pin), then connect it to socket J3 (22-pin) of board 1. Connect cable J5 to socket J3 of board 2.

STEP 5 – ANALOG OPTION BOARD CONNECTION (option)

Connect to the control cover using four (4) M4x25 pan head screws if one analog board is installed. Connect to the control cover using four (4) M4x40 pan head screws if two analog boards are installed.

Ensure that jumpers 1 and 2 are in the same position. If there is only one board, both should be in the

1-2 position (Board 1). If there are two boards, the second board should have the jumpers in

2-3 position. Connect J8 (3-pin) cable to J3 of board 1. Connect J3 (4-pin) cable to J1 of board 2.

STEP 6 – MODBUS – DDC NETWORK BOARD CONNECTION

Connect to the control cover using four (4) M4x25 pan head screws if one DDC board is installed. Ensure that Jumpers 1 and 2 are both in the “A” position. Connect the J7 6-pin cable from the terminal block to socket J2.

STEP 7 – PROFIBUS-DP NETWORK BOARD CONNECTION

Connect to the control cover using four (4) M4x25 pan head screws if one Profibus-DP board is installed. Ensure that both jumpers are in the “A” position. Connect the J7 6-pin cable from the terminal block to socket J8.

For Redundant Profibus-DP Network Board Connection:

Connect to the control cover using four (4) M4x40pan head screws. Ensure that primary board jumper (board “A”) is in the “A” position and redundant board jumper (board “B”) is in the “B” position. Connect the J7 6-pin cable from the terminal block to socket J8 on the “A” board and J3 4-pin connector for the redundant board “B”.

STEP 8 – PROFIBUS-PA NETWORK BOARD CONNECTION

Connect to the control cover using four (4) M4x25 pan head screws if one Profibus-PA board is installed. Ensure that both jumpers are in the “A” position. Connect the J7 6-pin cable from the terminal block to socket J8.

STEP 9 – FOUNDATION FIELDBUS NETWORK BOARD CONNECTION

Connect to the control cover using four (4) M4x25 pan head screws if one FOUNDATION Fieldbus board is installed. Ensure that both jumpers are in the “A” position. Connect the J7 6-pin cable from the terminal block to socket J8.

STEP 10 - DEVICENET NETWORK BOARD CONNECTION

Connect to the control cover using four (4) M4x25 pan head screws if one DeviceNet board is installed. Ensure that both jumpers are in the “A” position. Connect the 6-pin cable from the terminal block to socket J8. Set aside yellow ground wire to be fastened to top of option board stack per Figure 6.14. Above the shield, the wire must make contact with the screw.

STEP 11 – QX Quik (auxiliary) power board

▲ CAUTION: Use proper tools and only apply light pressure when installing standoffs to avoid damage to circuit board.

Installation without option boards:

1. Move JP1 jumper to the ‘NORM’ position
2. Insert PCB standoffs on unpopulated side of board in holes marked ‘B’ as shown in Figure 6.13
3. Plug ribbon cable into the J2 receptacle on main board as shown

Figure 6.12 Quik Power Without Option Boards

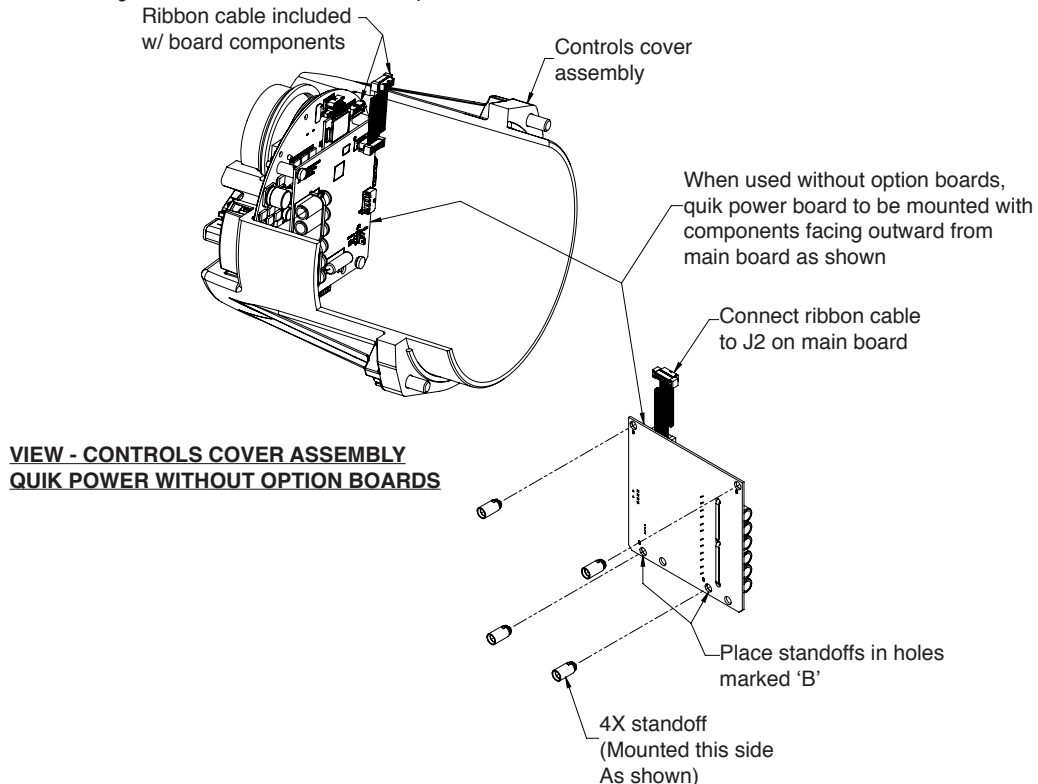

Installation with option boards:

1. Move JP1 jumper to the 'NORM' position
2. Insert PCB standoffs on populated side of board in holes marked 'A' as shown in Figure 6.13.
3. Mount board at end of board stack, plugging ribbon cable into the J2 receptacle on main board as shown

Figure 6.13 - Quik Power With Option Boards

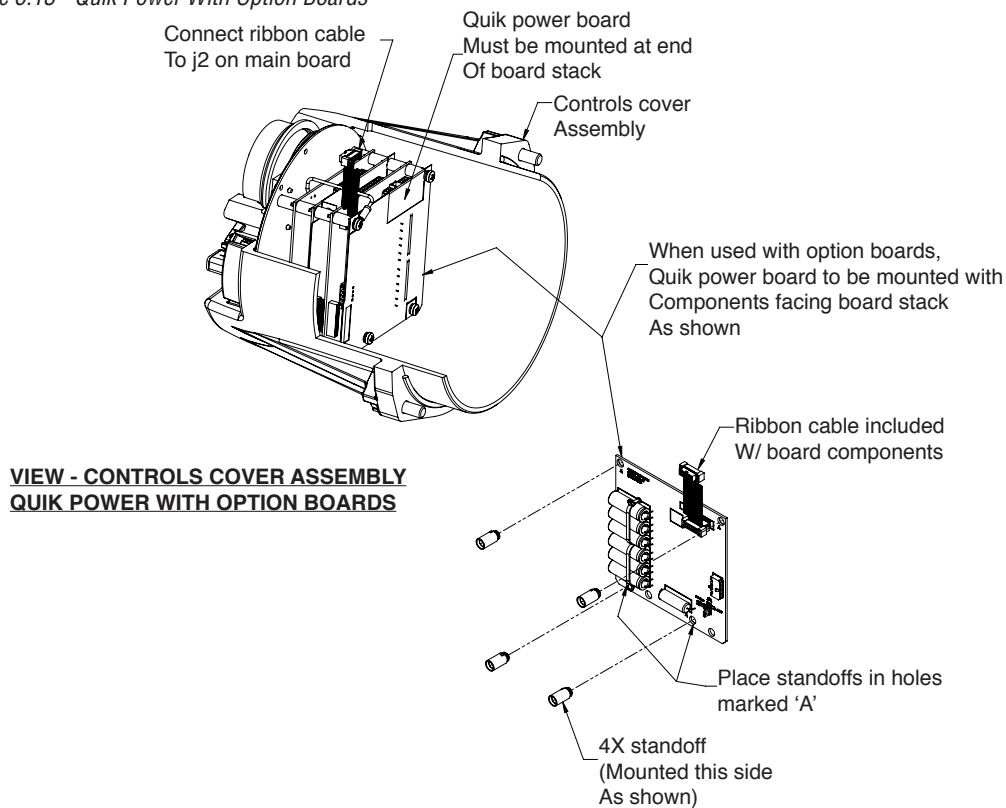

Work on electronics if Quik Board is installed

1. Cycle through CHANGE SETTINGS menu until you reach CHANGE BACKUP POWER.
2. Select YES
3. Select BACKUP POWER DISABLED – OK?
4. Select YES
5. Exit CHANGE SETTINGS MENU
6. Turn power off to actuator, LCD and LEDS should still operate once power is removed. This is due to the quik board still supplying power. Wait for unit to shut off.
7. Carefully remove electronics and Quik Board.
8. Locate JP1 (jumper) on JP1 of Quik Board and move to FAST DISCHARGE PINS.

STEP 12 – ALIGNMENT OF OPTION BOARDS INTO LCS/MAIN BOARD

Line up screw sockets and stack the boards so that J7 (option board pins and sockets) fits in with the main board or any boards that are installed previously. Place shield so sockets match up with cuts in shield. If DeviceNet board (61-825-0058-4) is used, position grounding wire on top of shield before fastening screws. Fasten four screws, then align in cover and install to main housing. Please refer to Table 6.10 for the connector numbers.

Table 6.10 - Control Board Connectors

Control Board	Connector Number
DeviceNet	X1
Foundation Fieldbus	X1
Profibus PA	X1
PBDP	X1
Digital Out	J2
Modbus/DDC	X1
Analog	J2

Figure 6.14 - Option Board Assembly

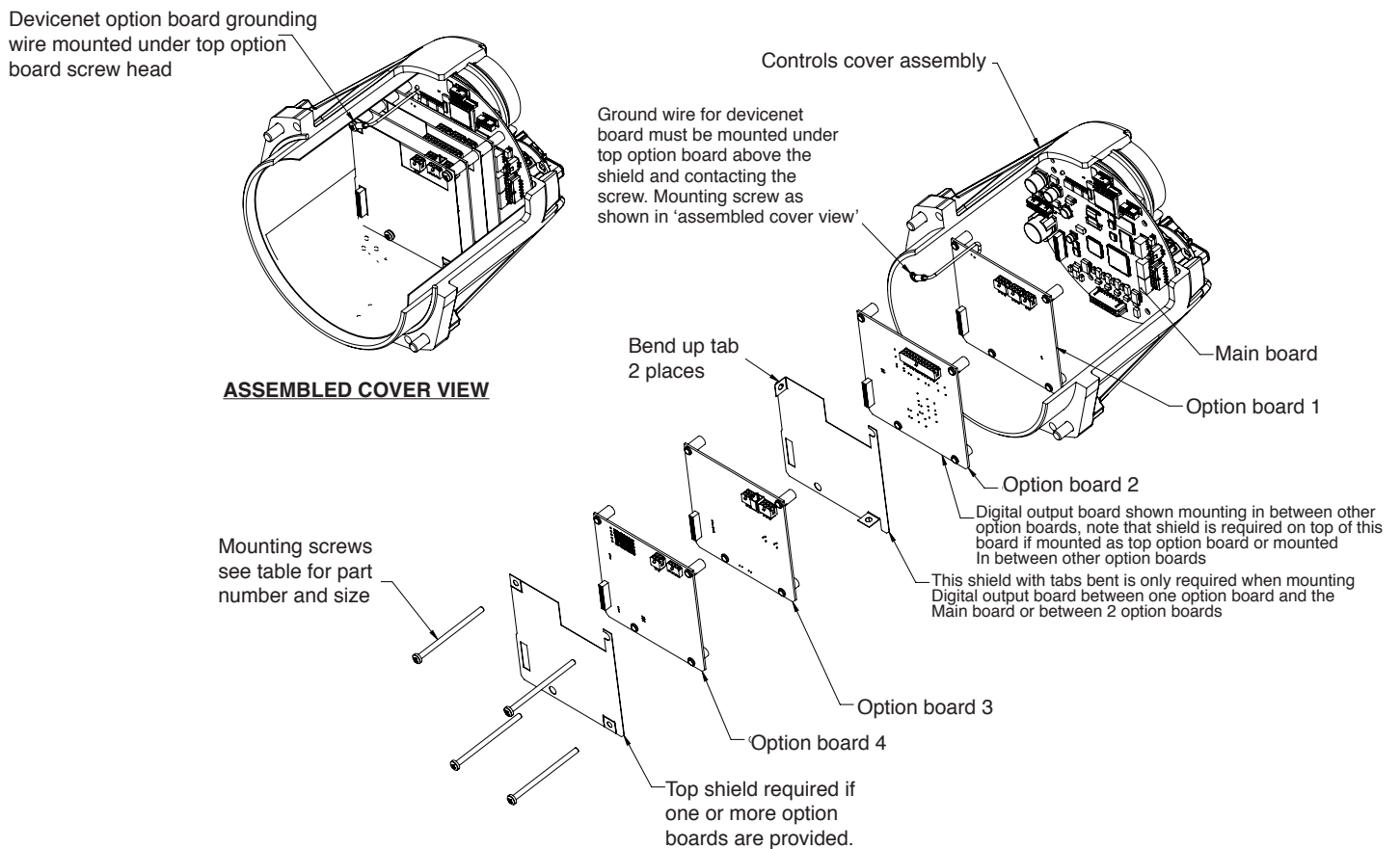

Table 6.11 - Screw Part Numbers

BOARD DESCRIPTION	SCREW PART NUMBER	DESCRIPTION	QTY.
MAIN WITH NO OPTION BOARDS	64-818-0001-35	M4X8	4
MAIN WITH 1 OPTION BOARD	64-818-0001-32	M4X25	4
MAIN WITH 2 OPTION BOARDS	64-818-0001-36	M4X40	4
MAIN WITH 3 OPTION BOARDS	64-818-0004-3	M4X55	4
MAIN WITH 4 OPTION BOARDS	64-818-0005-3	M4X70	4

▲ CAUTION: Potential to pinch cables. When remounting ACP cover, take special care no to pinch ribbon cables.

Dress the cables being careful to position wires so that they pass perpendicularly over the housing flange.

NOTE: The face of the ACP may be installed in any one of four 90° incremental positions. When changing ACP position, avoid over-twisting the ribbon cable(s).

Rotate the ACP until the display orientation of the front face is correct for normal viewing, and then slide the ACP assembly into the actuator housing.

6.5.2 Removal

For removal, follow installation instructions in reverse.

6.6 Optional Transformer

Table 6.12 - Optional Transformer Assembly

ITEM NUMBER	DESCRIPTION	QTY.
1	OPTIONAL TRANSFORMER SUBASSEMBLY	1
2	SOCKET HEAD CAP SCREWS	4
3	WIRING HARNESS	1

Figure 6.15 - Optional Transformer Assembly

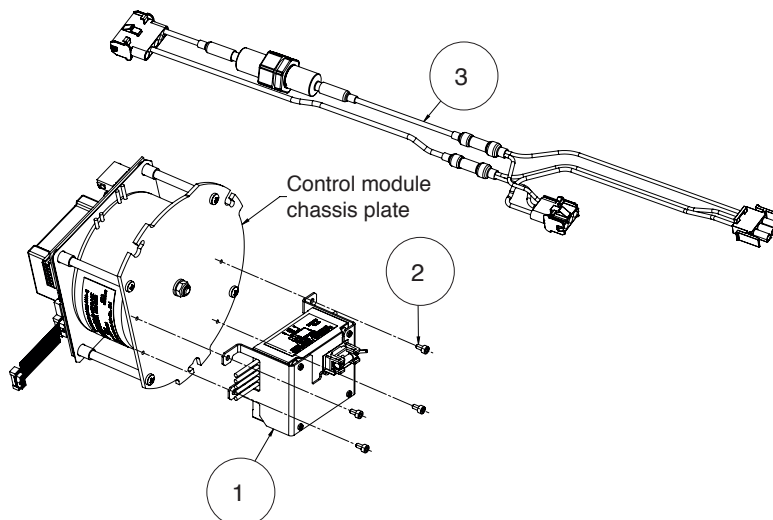

6.6.1 Optional Transformer Removal

- ⚠ **WARNING:** Hazardous Voltage! Turn off all power sources to actuator before removing control module assembly. Power sources may include main power or control power.
- ⚠ **CAUTION:** Potential to cause electrostatic damage to electronic components. Before handling electronic components, ensure that you are discharged of static electricity by briefly touching a grounded metal object.

Step 1

Remove controls cover per section 6-2.

Step 2

Remove control module per section 6-3.

Step 3

Using a M2.5 hex key, remove the four M3 screws (#2) holding the optional transformer assembly (#1) in place and remove from back of control module. If require unplug wiring harness (#3).

Table 6.13 - Optional Transformer Subassembly

ITEM NUMBER	DESCRIPTION	QTY.
1	BRACKET	1
2	OPTIONAL TRANSFORMER	1
3	SOVAL HEAD SCREW	4
4	FUSE BLOCK	1
5	SOCKET HEAD CAP SCREWS	1
6	HEX NUT	1
7	FUSE	1
8	SHIELD, FUSE BLOCK	1
9	SELF TAP SCREW	2

Figure 6.16 Optional Transformer Subassembly

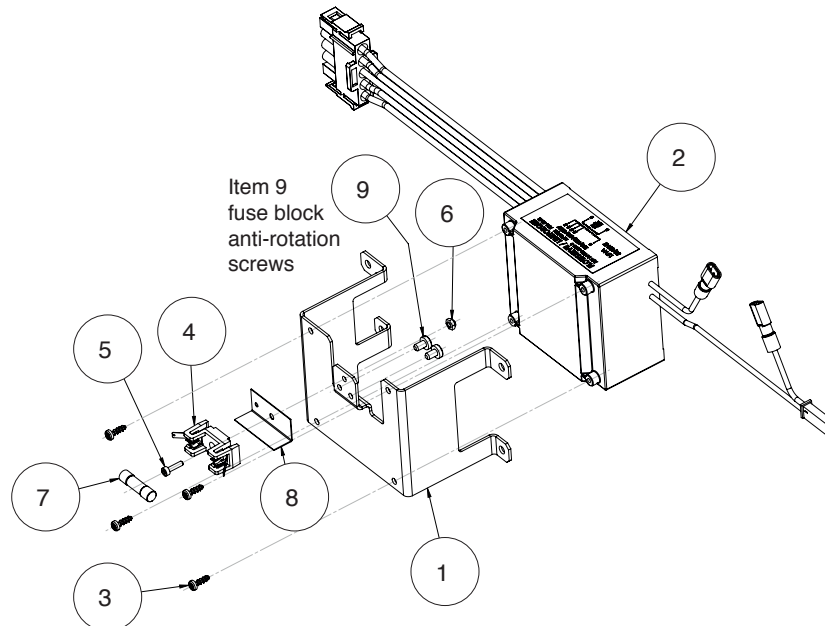

6.6.2 Optional Transformer Remounting

Step 1

Position optional transformer assembly (#1) to the 4 M3 taps on the back of the control module chassis plate, see Figure 6.16 for orientation. Fit the four M3 screws (#2) thru bracket holes aligning with the taps in on the control module and using a M2.5 hex key tighten the four M3 screws.

Step 2

Connect wiring (See section 7 for wiring connections). Note that the optional transformer wiring harness (#3) must have the correct wire to connector position per voltage supply (See Table 7.1).

7 Electronic Wiring (Cabling)

7.1 AC Low Voltage Wiring (Cabling) Quick Reference Guide for Control Module and Main Board. (Less than 250 VAC)

7.1.1 AC Low Voltage Module (Version 1).

Figure 7.1 is a diagram that shows wiring locations for a low voltage QX unit with version 1 motor controller board. Motor controller board part number 68-825-0007-4.

Figure 7.1 - Low Voltage QX Unit Wiring Connections

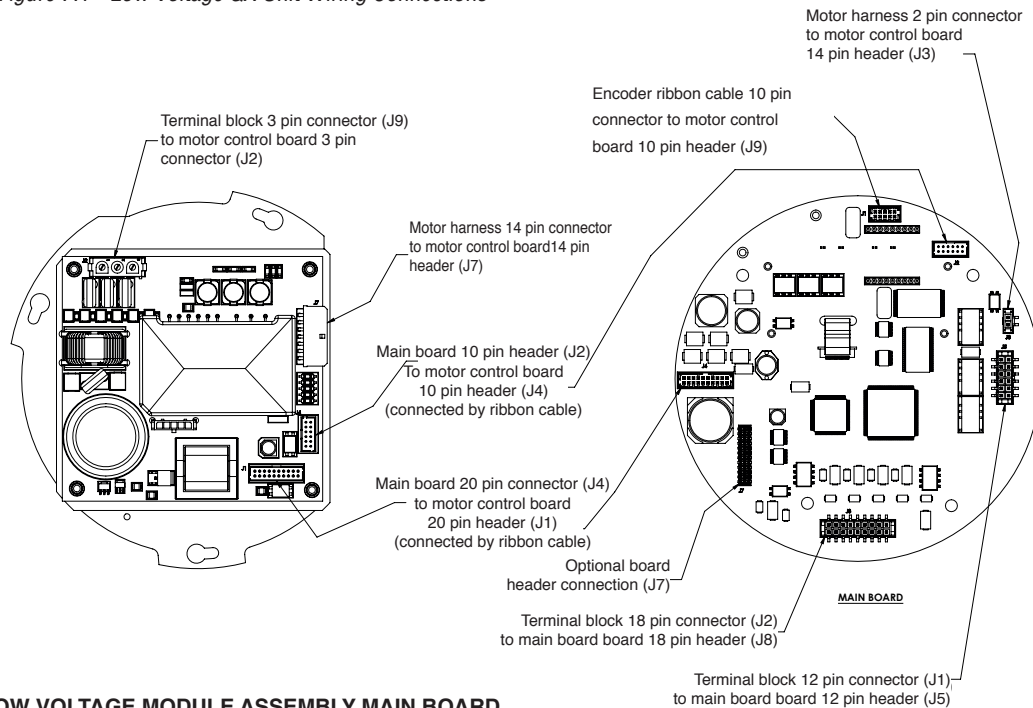

LOW VOLTAGE MODULE ASSEMBLY MAIN BOARD WITH MOTOR CONTROLLER BOARD 68-825-0007-4

7.1.2 AC Low Voltage Module (Version 2).

Figure 7.2 is a diagram that shows wiring locations for a low voltage QX unit with version 2 motor controller board. Motor controller board part number 68-825-0012.

Figure 7.2 - Low Voltage QX Unit Wiring Connections (Version 2)

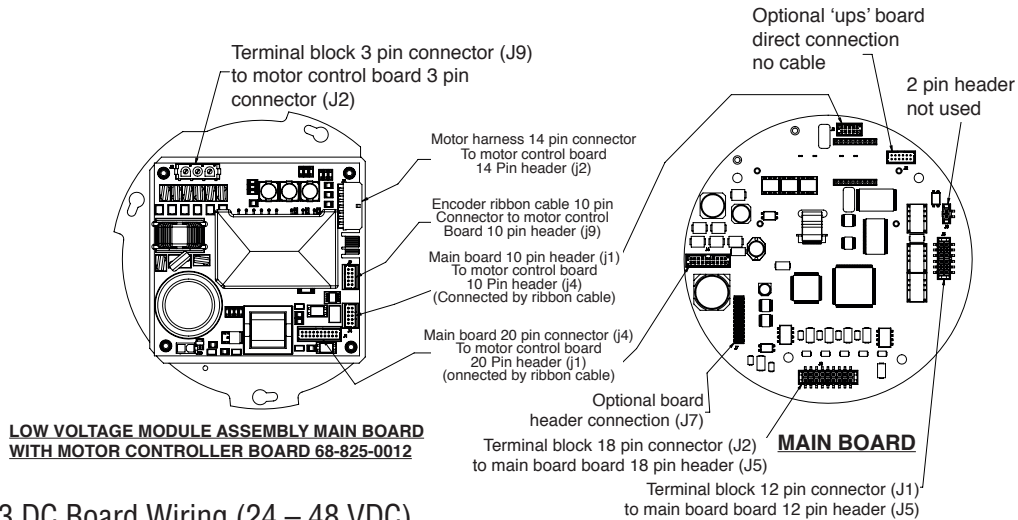

7.1.3 DC Board Wiring (24 – 48 VDC)

Figure 7.3 shows wiring locations for the DC QX unit. All other wiring is the same as the low voltage wiring.

Figure 7.3 - DC QX Unit Wiring Connections

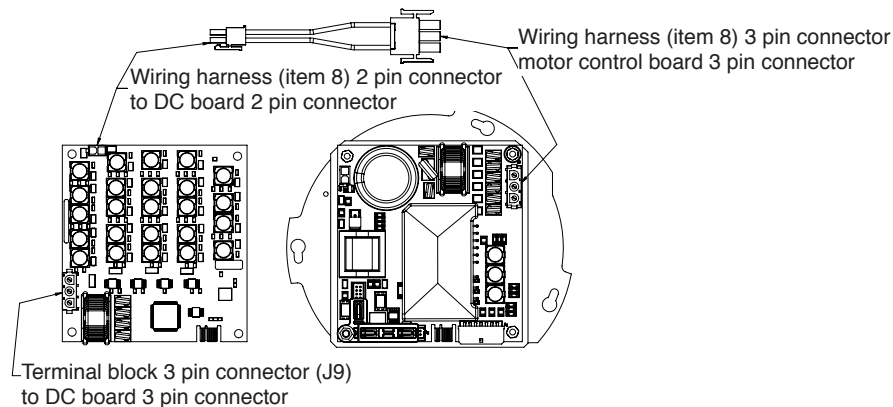

7.2 High Voltage Wiring (Cabling) Quick Reference Guide. (Greater than 250 VAC)

7.2.1 High Voltage Module

Figure 7.4 is a diagram that shows wiring connections for QX unit with a high voltage module with toroid transformer. Control supply (power in) from L1, L2 and L3 from terminal block connector (J9) now connects to the toroid transformer and the toroid transformer connects to the motor controller board (J2). All other wiring is the same as the low voltage wiring.

Figure 7.4 - High Voltage QX Unit Wiring

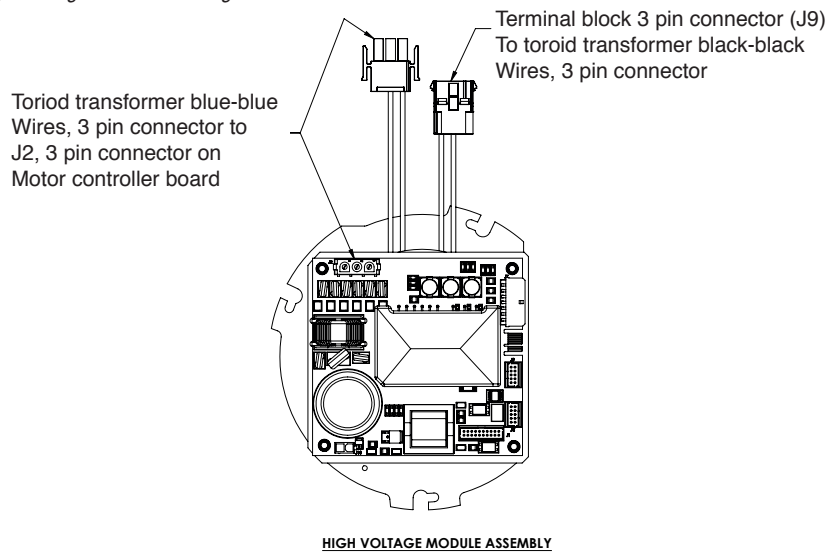

NOTE: Check to make sure the toroid transformer has the correct 'PRI' voltage values for the application. See Figure 7.5 for typical labeling of toroid transformer.

Figure 7.5 Typical Toroid Transformer Label

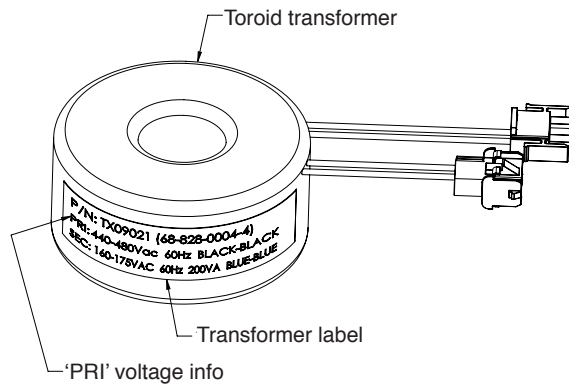

7.3 Optional Transformer Wiring (Cabling) Quick Reference Guide

The optional transformer uses a separate wiring harness to connect the controls supply (power in from L1, L2 and L3) terminal block connector (J9) to the control module and optional transformer. See below for wiring configurations. All other wiring is the same as the low or high voltage connections.

NOTE: See Figure 7.9 for wiring harness configurations per supply input voltage.

7.3.1 Optional Transformer Harness Wiring Used With Low Voltage Control Module

Figure 7.6 - Optional Low Voltage Transformer Harness Wiring

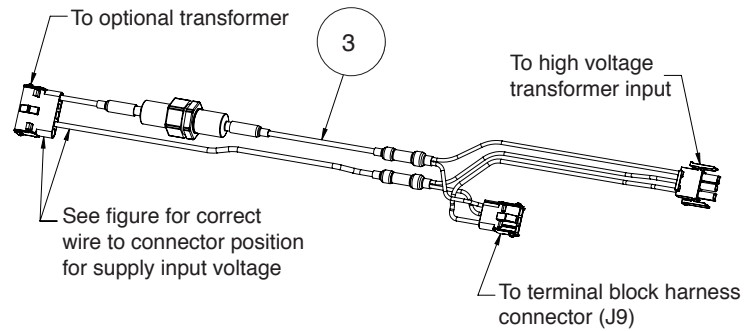

7.3.2 Optional Transformer Harness Wiring Used With High Voltage Control Module

NOTE: See Figure 7.8 for harness routing around toroid transformer assembly.

Figure 7.7 - Optional High Voltage Transformer Harness Wiring

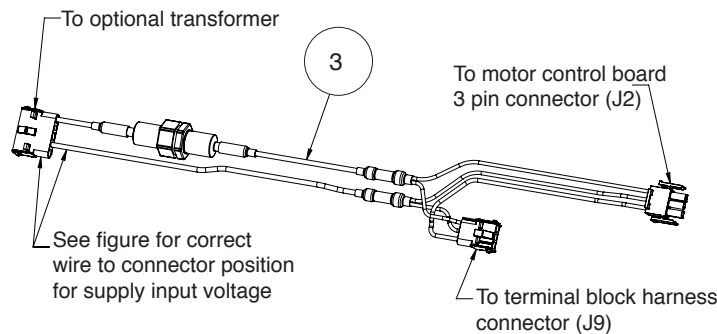

7.3.3 Optional Transformer Harness Routing Used With High Voltage Control Module

The wiring harness (#3) when used with the high voltage toroid transformer assembly should be routed as show below in Figure 7.8.

Figure 7.8 - High Voltage Optional Transformer Harness Assembly Routing

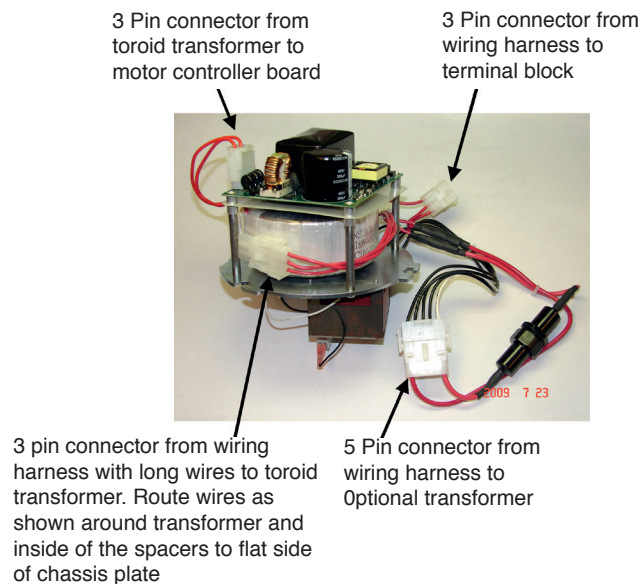
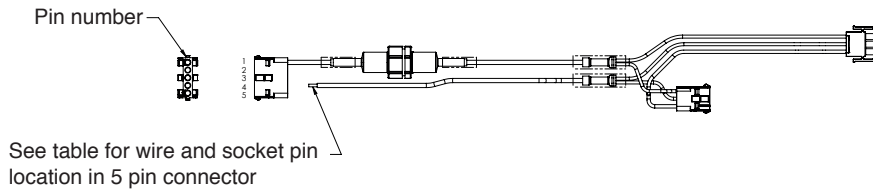

Figure 7.9 - Optional Transformer Harness Connector to Wire Position per Supply Voltage



WIRE AND PIN LOCATION IN 5 PIN CONNECTOR	VAC POWER SUPPLY		
	OPTIONAL TRANSFORMER DWG. 64-828-0004-3	OPTIONAL TRANSFORMER DWG. 64-828-0005-3	OPTIONAL TRANSFORMER DWG. 64-828-0006-3
PIN NUMBER 2	90-104vac	210-240vac	NA
PIN NUMBER 3	105-128vac	342-390vac	496-560vac
PIN NUMBER 4	187-209vac	391-420vac	NA
PIN NUMBER 5	NA	421-495vac	561-600vac

Table 7.1 Connector to Wire Position per Supply Voltage

Wire and Pin Location in 5 Pin Connector	VAC Power Supply		
	Optional Transformer	Optional Transformer	Optional Transformer
	DWG. 64-828-0004-3	DWG. 64-828-0005-3	DWG. 64-828-0006-3
PIN NUMBER 2	90-104vac	210-240vac	N/A
PIN NUMBER 3	105-128vac	342-390vac	496-560vac
PIN NUMBER 4	187-209vac	391-420vac	N/A
PIN NUMBER 5	N/A	421-495vac	561-600vac

7.4 Terminal Block Wiring Harness Numbers

Figure 7.10 - Terminal Block Wiring Harness And Connector Numbers

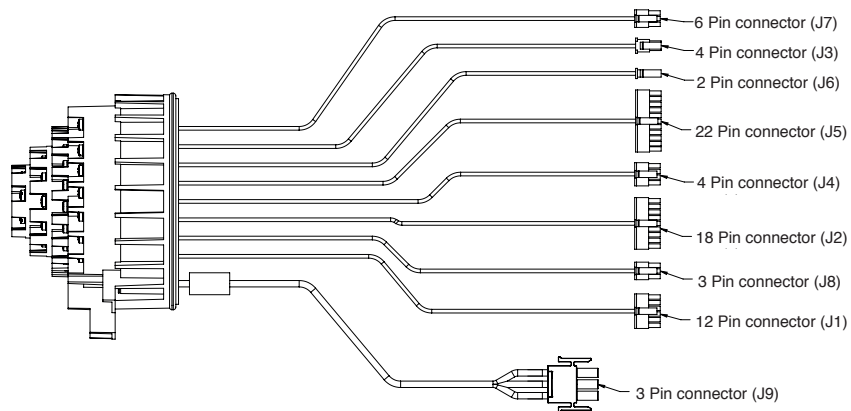

8

Spares and Replacement Parts

8.1 Guidelines for Recommended Spare Parts

Since every Flowserve Limitorque actuator is designed to meet a specific application, the recommended spare parts needed to support the actuator will vary for every project. The following guidelines are provided to assist in determining the specific spare parts requirements for your QX actuators.

8.1.1 Wear Components

The following components will eventually wear under normal use and should therefore be planned as spares. The expected lifetime of these parts will vary from application to application. They are listed in order of most frequent to least frequent replacement. Flowserve recommends stock levels of between 5% and 10% of the total population of each part with a minimum of one of each in order to support the product for life.

1. Stem nut
2. Worm shaft subassembly
3. Drive sleeve subassembly

8.1.2 Bearings, O-rings, and Seals

All bearings should be replaced any time an actuator is refurbished. Therefore, all bearings should be planned for stock for any scheduled refurbishment. In addition, any O-ring or seals should be replaced any time an actuator is disassembled. Complete actuator seal kits are available for the QX-1, 2, 3, 4, and 5.

Flowserve recommends stock levels for seal kits of 10% of the total population of each actuator model and size. Also, an adequate supply of Flowserve approved oil (See Section 2.3.2) should be maintained in stock to support any necessary maintenance or refurbishment.

8.1.3 Critical Components

The following parts are not subject to wear but are still recommended for stock due to their critical nature. Flowserve recommends stock levels of between 5% and 10% of the total population of each part with a minimum of one of each in order to support the product for life.

1. Motor
2. Encoder
3. Control module

8.2 Recommended Spare Parts for QX Actuators

8.2.1 Commissioning and Startup

No additional spare parts are required. All necessary spares are included in the end-user bag.

8.2.2 Short-Term Duty

This is defined as up to 5000 seats or up to 1 million drive sleeve operations, whichever occurs first. There are no spare parts required for the actuator during short-term duty.

8.2.3 Long-Term Duty

This is defined as service beyond short-term duty but less than 10,000 seats and less than 1.5 million drive sleeve operations. The spares suggested for long-term duty are as follows:

- Quad rings at the top and bottom of the drive sleeve
- Drive sleeve assembly, which includes the worm gear
- Wormshaft assembly
- Encoder cartridge assembly
- Motor assembly
- Fuse (Controls, quantity 1)
- Fuses (Power, quantity 2)
- Encoder assembly
- Motor controller board
- Control module (includes PCB-power, main, CP, and optional DDC and I/O boards)
- Bronze stem nut for thrust base (multi-turn QXs only)

NOTE: Oil should be changed every 10,000 seats or sooner if the oil has been contaminated with water or other foreign material.

8.2.4 Severe Duty

This is defined as open/close service when run loads exceed 50% of the unit rating. This also includes all modulating applications.

NOTE: Oil should be changed every 5000 seats for open/close service, or sooner if the oil has been contaminated.

The spares suggested for severe duty are identical to the long-term duty spares.

8.3 Other Concerns

There are other unique application requirements that may result in additional parts being added to the list of recommended spares. Some additional issues or requirements that should be considered when determining required spare parts include (but are not limited to):

1. Maintenance program
2. Frequency of operation
3. Modulating duty
4. Frequent operation by handwheel
5. Regular testing
8. Stall/overload condition

Flowserve strongly recommends using OEM parts to support and maintain your QX actuator. Installing parts other than genuine Flowserve Limitorque parts could cause premature failure of your actuator and voids any remaining warranty.

The above guidelines are provided to assist you in determining your unique spare parts needs. Please contact your local Limitorque Sales Office or local Authorized Stocking Distributor for additional help in evaluating your needs.

9 Regulatory Information

9.1 Declaration of Conformity

Application of Council Directive(s)

2004/108/EC; EMC Directive
2006/42/EC; Machinery Directive
2003/10/EC; Airborne Noise Directive
94/9/EC; ATEX Directive

Standard(s) to which Conformity is Declared

Machinery; EN 60204-1

EMC - Emissions; EN 50081-1&2, EN 55011, CFR 47
Immunity; EN 50082-1&2, IEC 801-3 & IEC 801-6
ESD; IEC 801-2
EFT/Bursts; IEC 801-4
Surge Immunity; IEC 801-5, ANSI/IEEE C62.41
Mains (power) Harmonics; MIL-STD-462, Method CS01 & CS02

Airborne Noise; MIL-STD-740-1, Table 1, and EN 60204

ATEX Harmonized Standards

prEN 60079-0:200X (IEC 60079-0:2007)
EN 60079-1:2007
EN 60079-7:2007
EN 60529:1991 + A1:2000
EN 13463-1: 2009
EN 13463-5: 2003

Materials of Construction Terminal & Control Covers - Aluminum Alloys 380 or 383

CS Station - Aluminum Alloy 319

Nameplate - Stainless Steel

Housing - 356-T6 Aluminum

Window - Heat tempered Soda Lime Glass

Antenna Cover - Polytetrafluoroethylene

EMC - Electromagnetic Compatibility (EMC) and Electromagnetic Interference (EMI) standards to which this actuator complies:

APPLICABLE EMISSIONS STANDARDS	EN50011:1998	CLASS A SERVICE	
Radiated emissions	EN55011:1998 & FCC Part 15, subpart J	30-130MHz 40dBmV / m 230-1000MHz 47dBmV / m	
Conducted emissions	EN55011:1998 & FCC Part 15, subpart J	0.15 to 0.5MHz 79dBmV (QuasiPeak 66dBmV avg) 0.5 to 30MHz 73dBmV (QuasiPeak 66dBmV avg)	
Applicable immunity standards	IEC EN 6100-6-1:2001		
ESD	IEC6100-4-1:1995	±8kV thru air ±4kV thru contact	
Radiated RF immunity	IEC6100-4-3:1995	80MHz to 2GHz 10Vrms / m	
Fast transients/burst	IEC6100-4-4:1995	EFT AC Power leads ±2kV Signal leads: ±1kV	
Voltage surges	IEC6100-4-5:2001	AC Power: ±2kV com, ±1kV diff Signal leads: ±0.5kV com, ±1kV diff	Perf criterion: B
Conducted RF immunity	IEC6100-4-6:1996	150kHz to 80MHz 10Vrms	Perf criterion: A w/80% AM modulation @1KHz
Magnetic field immunity	IEC6100-4-8:1993	Power line frequency 30A/m @60Hz	Perf criterion: A
Voltage dips and interrupts	IEC6326-1:2005 (IEC61000-4-11:2004)	60Hz 100% dip, 1 cycle duration 40% dip, 10 cycle duration 70% dip, 25 cycle duration 100% dip, 1 cycle duration	Perf criterion: B, C 3 test each @ 10 sec interval 3 test each @ 10 sec interval 3 test each @ 10 sec interval 3 test each @ 10 sec interval

Notified Body

FM Approvals Limited
1 Windsor Dials
Windsor UK
Certification Number
FM09ATEX0058X"

IECEX

IEC 60079-0:2007
IEC 60079-1:2007
IEC 60079-7:2006
IEC 60529:1989 + A1:1999

Manufacturer's Name

Limitorque, a division of Flowserve Corporation

Manufacturer's Address

5114 Woodall Road
Lynchburg, VA 24502

Importer's Name

Limitorque International

Importer's Address

Euro House
Abex Road
Newbury
Berkshire, RG14 5EY
England

Type & Description of Equipment

Valve Actuators

Model Number

QX Series Note: Tested with Limitorque products only and with standards applicable at time of tests.

I, the undersigned, hereby declare that the equipment specified above conforms to the above Directive(s) and Standard(s). List as follows:

(Signature)
Earnest Carey
(Full Name)

Principal Product Portfolio Manager and Marketing Manager
(Title)

Flowserve Limitorque
5114 Woodall Rd., Lynchburg VA 24502

(Place)
February 2011
(Date)

9.2 Specific Conditions for Use — Atex/Cenelec/IECEx Applications

Atex/Cenelec/IECEx certification of the QX product line is described in Certificate of Conformity. This certificate details specific construction requirements that must be met in order to maintain the XP integrity of the actuator. The sockethead cap screws used with the QX electric valve actuators shall conform to the following requirements:

The “X” suffix to the Certificate number relates to the following specific conditions of use.

1. ISO Class 12.9, M8 socket-head cap screws (Yield Stress 1100 MPa) shall be used to replace the terminal, control, or motor compartment fasteners of actuators marked with TAMB < -20°C or for all Group IIC actuators.
2. Stainless steel, A2 or A4, ISO Class 70, M8 socket-head cap screws (Yield Stress 450 MPa) shall be permitted as an alternate to the ISO Class 12.9 socket-head cap screws on the terminal, control, or motor compartments of actuators marked TAMB ≥ -20°C.
3. Consult the manufacturer if dimensional information on the flameproof joints is necessary.

9.3 Statement of Compliance with Applicable European Directives

We, Flowserve Limitorque, 5114 Woodall Road, Lynchburg, VA, USA 24502, as the manufacturer of the equipment listed below:

QX-1, 2, 3, 4, 5 electronic valve actuator. The QX is a non-intrusive electronic actuator. It is specifically designed for the purpose of being mounted to a quarter turn valve (or other apparatus) in order to move the valve from fully closed to fully open.

Confirm, in accordance with the requirements of clause 1.2.7 of the Essential Health and Safety Requirements of Community Directive 94/9/EC on equipment and protective systems intended for use in potentially explosive atmospheres that the above equipment has been designed and manufactured to:

- a) Avoid physical injury or other harm which may be caused by direct or indirect contact;
- b) Assure that the surface temperature of accessible parts or radiation which cause a danger, are not produced;
- c) Eliminate non-electric dangers which are revealed by experience;
- d) Assure that foreseeable conditions of overload shall not give rise to dangerous situations.

And where these risks are wholly or partly covered by other Community Directives, the equipment satisfies the requirements of those specific Directives. And that literature describing the equipment will not contradict the instructions with regard to safety aspects.

Issued on: February 2011

Authorized by:

Name: Earnest G. Carey, Jr.

Position: Principal Product Portfolio Manager and Marketing Manager

(Authorized EU Representative)



Flowserve Corporation Flow Control

United States

Flowserve Limatorque
5114 Woodall Road,
P.O. Box 11318
Lynchburg, VA 24506-1318
Phone: 434-528-4400
Facsimile: 434-845-9736

England

Flowserve Limatorque
Euro House
Abex Road
Newbury
Berkshire, RG14 5EY
United Kingdom
Phone: 44-1-635-46999
Facsimile: 44-1-635-36034

Japan

Limatorque – Nippon Gear Co., Ltd.
Asahi-Seimei Bldg. 4th Floor
1-11-11 Kita-Saiwai, Nishi-Ku
Yokohama-Shi, (220-0004)
Japan
Phone: 81-45-326-2065
Facsimile: 81-45-320-5962

Canada

Flowserve Limatorque
120 Vinyl Court
Woodbridge, Ontario L4L 4A3
Canada
Phone 905-856-4565
Fax 905-856-7905

Singapore

Limatorque Asia, Pte., Ltd.
12, Tuas Avenue 20
Singapore 638824
Phone: 65-6868-4628
Facsimile: 65-6862-4940

China

Limatorque Beijing, Pte., Ltd.
RM A1/A2
22/F, East Area, Hanwei Plaza
No. 7 Guanghua Road, Chaoyang District
Beijing 100004, Peoples Republic of China
Phone: 86-10-5921-0606
Facsimile: 86-10-6561-2702

India

Flowserve Limatorque
No.10-12, THE OVAL, Third floor
Venkatnarayana Road
T. Nagar, Chennai 600 017
Phone: 91-44-2432-8755
& 91-44-2432-4801
Facsimile: 91-44-2432-8754

*To find your local Flowserve representative,
visit www.flowserve.com/limitorque, www.limitorque.com
or call USA 1 434 528 4400*

FCD LMENIM3314-01 06/2018 Printed in USA.

Flowserve Corporation has established industry leadership in the design and manufacture of its products. When properly selected, this Flowserve product is designed to perform its intended function safely during its useful life. However, the purchaser or user of Flowserve products should be aware that Flowserve products might be used in numerous applications under a wide variety of industrial service conditions. Although Flowserve can (and often does) provide general guidelines, it cannot provide specific data and warnings for all possible applications. The purchaser/user must therefore assume the ultimate responsibility for the proper sizing and selection, installation, operation, and maintenance of Flowserve products. The purchaser/user should read and understand the Installation Operation Maintenance (IOM) instructions included with the product, and train its employees and contractors in the safe use of Flowserve products in connection with the specific application.

While the information and specifications contained in this literature are believed to be accurate, they are supplied for informative purposes only and should not be considered certified or as a guarantee of satisfactory results by reliance thereon. Nothing contained herein is to be construed as a warranty or guarantee, express or implied, regarding any matter with respect to this product. Because Flowserve is continually improving and upgrading its product design, the specifications, dimensions and information contained herein are subject to change without notice. Should any question arise concerning these provisions, the purchaser/user should contact Flowserve Corporation at any one of its worldwide operations or offices.

© 2011 Flowserve Corporation, Irving, Texas, USA. Flowserve is a registered trademark of Flowserve Corporation.