

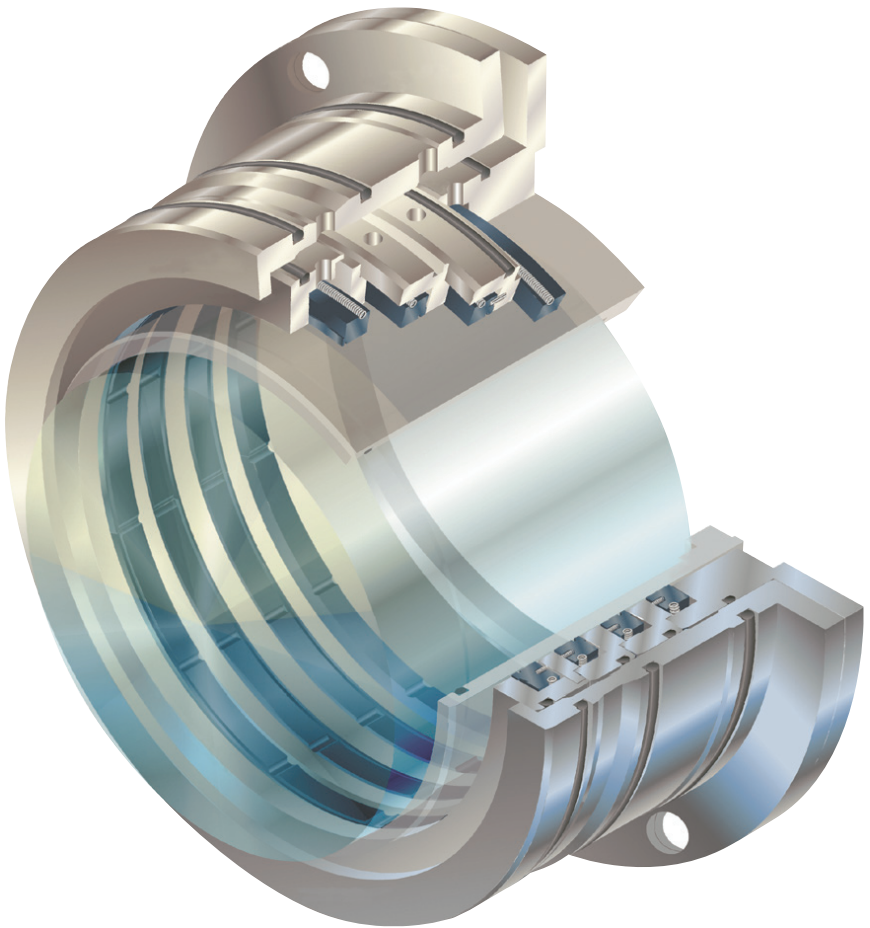

Installation Instructions

Circpac HP

Segmented Circumferential Gas Seal for Gas Compressors



1 Precautions

- 1.1 Please read these instructions carefully. Installation in accordance with the following instructions will contribute to long, trouble-free life of the Circpac HP.
- 1.2 For related control panels or other auxiliary equipment, separate instructions are required.
- 1.3 The Circpac HP and related equipment must be transported and stored in the unopened, original shipping container. Warehouse storage must be clean and dry.
- 1.4 The ultimate user must ensure that personnel assigned to handle, install, and operate the Circpac HP and related equipment are well acquainted with the design and operating requirements of such equipment. The manufacturer is not liable for damage incurred through improper handling, installation or use.

2 Brief Description

- 2.1 The Circpac HP is an engineered, segmented circumferential gas seal for gas compressors. Each seal is custom designed for a specific application and should only be operated according to the limits of the specific application.
- 2.2 The Circpac HP is delivered as a complete, ready-to-install cartridge unit. Depending on the application, the cartridge may include a sleeve (preferred).
- 2.3 Dynamic sealing occurs between the stationary circumferential ring and the rotating sleeve/shaft where pressure breaks down across the sealing surface. Static sealing occurs at gasket points and between the stationary ring and stationary housing. The ring is designed to contact the sleeve/shaft to minimize gas leakage.
- 2.4 Depending on the application, multiple ring configurations may be used. Examples include: tandem for high pressure, double for zero emissions, and bearing purge for oil containment. Proper piping, control system design, and system operation are required for long-term seal performance. If zero product emissions are desired, barrier gas at a higher pressure than the product is required at all times.
- 2.5 Long-term seal performance is best attained if the following conditions are sustained. Failure to comply with these conditions may result in excessive gas consumption and/or product leakage to the atmosphere.
 - 2.5.1 Good equipment condition and consistent operation within the equipment manufacturer's specifications.
 - 2.5.2 Perpendicular orientation between the shaft sleeve and the equipment housing.

- 2.5.3 Minimum runout between the shaft and equipment housing.
 - 2.5.4 Prevention of product sedimentation on the housing, shaft or sleeve by crystallization, polymerization, or any other product sedimentation.
 - 2.5.5 Proper maintenance and operation of the gas control system.
- 2.6 Refer to the seal assembly drawing for materials of construction, seal orientation, and any special installation instructions. If any questions arise, please contact a Flowserve representative for support.

3 Equipment Check

- 3.1 Follow plant safety regulations prior to equipment disassembly, including at least the following basic procedures.
 - 3.1.1 Wear designed personal safety equipment
 - 3.1.2 Lock out equipment driver and valves
 - 3.1.3 Isolate equipment and relieve any pressure in the system
 - 3.1.4 Consult plant Material Safety Data Sheet (MSDS) files for hazardous material regulations.
- 3.2 Disassemble equipment in accordance with the equipment manufacturer's instructions to allow access to seal installation area.
- 3.3 Remove existing sealing arrangement. Clean seal chamber and shaft thoroughly.
- 3.4 Verify shaft dimensions as shown on the seal assembly drawing.
- 3.5 Verify seal chamber pilot fit(s) as shown on the seal assembly drawing.
- 3.6 Inspect surfaces at gaskets to ensure they are free from damage such as pits and scratches. Horizontal sealing surfaces such as the shaft OD and seal chamber bore must not exceed 16 RMS surface finish. Radial sealing surfaces such as the chamber face must not exceed 64 RMS surface finish.
- 3.7 Check seal assembly drawings for any modifications (reworks) to be made of the equipment and act accordingly.
- 3.8 Shaft runout should not exceed 0.025 mm (0.001 inch) TIR (Total Indicator Reading) at any point along the shaft. If the equipment is not completely dismantled, verify runout near seal location.
- 3.9 Shaft end play should not exceed 0.10 mm (0.004 inch) TIR.
- 3.10 Radial shaft movement should be checked against the equipment manufacturer's specification.

- 3.11 Seal chamber squareness to the shaft center line should be within 0.013 mm per 25.4 mm (0.0005 inch per 1 inch) shaft diameter.

Note: Make sure that shaft end play does not affect the reading.

- 3.12 Concentricity of the shaft to the seal chamber bore should be within 0.025 mm per 25.4 mm (0.001 inch per 1 inch) shaft diameter to a maximum of 0.13 mm (0.005 inch) TIR.
- 3.13 Break all sharp corners on shaft steps, threads, reliefs, shoulders, key ways, port holes, etc. across which gasket(s) must pass and /or seal against.

4 Seal Installation

- 4.1 Review Circpac HP assembly drawing and seal assembly instructions prior to installation. Particularly follow special instructions listed on the assembly drawing.
- 4.2 Apply a thin coat of lubricant to all gaskets. The lubricant must be compatible with both the product and gasket materials. Generally, silicon grease is suitable.
- 4.3 If the Circpac HP does not have a cartridge sleeve, verify that the segmented rings are centered in the seal housing. Some sleeveless assemblies provide a guide plug that centers the rings and aligns with the shaft. Pay extra attention to cleaning the shaft.
- 4.4 Orient the ports on the seal housing(s) as indicated by the seal assembly drawing and connection piping. Line up the seal housing(s) bolt holes with those on the machine.
- 4.5 Slowly and carefully slide the seal along the shaft while maintaining tight parallelism between the shaft and seal bore until located against the face of the seal chamber. If a guide plug is used, allow the plug to be displaced by the shaft. If the equipment manufacturer provides installation tools, use these per the instructions.
- 4.6 Evenly torque gland bolts/nuts to prevent cocking of the gland or uneven gland pressure against the seal chamber. For sleeved designs, do not fasten drive arrangement.
- 4.7 Complete the remaining equipment assembly including bearings, if applicable.
- 4.8 Ensure the setting plates are correctly located and engaged.
- 4.9 For sleeved designs, fasten drive arrangement to the setting values shown on the seal assembly drawing, making sure the shaft is in the same position as when the equipment is operating.

- 4.10 Disengage setting plates and store separately.
- 4.11 Inspect equipment and driver alignment in accordance with coupling and/or equipment manufacturer's instructions.

5 Piping and Control System

- 5.1 Proper piping and control system installation are imperative to correct seal operation. Piping ports are detailed on the mechanical seal assembly drawing and clearly marked on the mechanical seal housing. Installation and operating instructions specific to Flowserve control panels are available separately and must be carefully followed.
- 5.2 Piping connections may include combinations of the following examples where multiple descriptions may apply to each port connection.
 - **Double barrier** – inject clean external gas between a pair of rings at a pressure typically 0.3 – 0.7 bar (5 – 10 psi) above upstream ring pressure for zero emissions.
 - **Tandem purge** – inject clean external gas between a pair of rings at a pressure lower than upstream ring pressure and vent from the same pair to a low pressure flare.
 - **Inboard gas purge** – inject clean external gas or filtered product gas between the first pair of rings at slightly higher pressure than product (typically 0.2 - 0.3 bar [3-5 psi] differential) to maintain clean inboard rings.
 - **Bearing purge** – inject clean external gas before bearing ring at higher pressure than bearing cavity (typically 0.2 – 0.3 bar [3 – 5 psi] differential) for the purpose of restricting oil ingress, typically vented through a dedicated port.
 - **Sensing/reference** – connection to the reference port of a differential pressure regulator to maintain constant purge or barrier pressure differential across the downstream ring.
 - **Vent** – connection to low pressure flare system or other approved destination where vent pressure is the lowest pressure piping connection.
 - **Drain** – disposal of liquids including condensate or bearing oil and for maintenance procedures such as in-place cleaning.
 - **Tandem sensing** – connection to a pressure gage or transducer to monitor the pressure between ring stages as a measure of seal performance.

- 5.3 Size piping system for required flow rates. Minimize restrictions and determine total pressure drop(s) through piping system to ensure adequate seal pressure.
- 5.4 Unless otherwise specified, dirty process gas must be separated from the inner ring to prevent excessive wear or erosion. For example, an inner ring purge with at least 0.2 – 0.3 barg (3 – 5 psid) will prevent dirty process from contaminating the rings. Purge and barrier gases must be clean to less than 4 micron (10 mmm) particles.
- 5.5 During commissioning and before operation, all supply lines should be disconnected and blown out to ensure they are clean and free from any moisture, solids or debris.

6 Operational Recommendations

- 6.1 The pressure and temperature in the seal cavity or gas control system must not exceed the recommended maximum seal limits. The shaft speed must also not exceed seal limits. Optimum seal/control system performance is achieved when the equipment is operated at the conditions for which the seal was designed. Consult your Flowserve representative if operating conditions change.
- 6.2 Barrier pressure(s) and purge pressure(s) should be energized prior to starting the equipment and prior to starting the lube oil pump. Likewise, do not remove pressure until the equipment has been fully isolated, depressurized, and vented and the post lube has shut down.
- 6.3 For seals using external cooling and/or an external flush, start cooling and/or flush prior to seal start-up.
- 6.4 Use a barrier/purge gas that is compatible with the product and all seal materials of construction. Also consider environmental effects of barrier/purge gas selection.
- 6.5 This seal is designed to resist corrosion by the product(s) listed on the assembly drawing. Do not expose the seal materials to product other than those shown on the assembly drawing. The seal assembly drawing lists the materials of construction. Consult your Flowserve representative when in doubt or when using the seal for another application.
- 6.6 Start up equipment in accordance with normal operating procedures unless specifically requested otherwise by Flowserve. If the equipment is not operating properly (e.g. seals and/or bearings running hot, heavy vibration, pressure reversals, contamination, etc.), shut down the equipment and investigate the cause. Depending on the significance of such events, Flowserve should be consulted for seal advice.

7 Off-Site Performance Testing

- 7.1 Equipment manufacturers will often execute performance tests with the Circpac HP installed on new or retrofit equipment. Some seal designs will require replacement of the seal rings if testing exceeds the seal design's specific operating window including pressure, temperature, speed, and fluid media.
- 7.2 Witness testing of the seal design on simulated equipment may similarly result in replacement of the seal rings. Although the disposition of the seal rings is usually known prior to performance testing with provisions specified in the sales contract, contact your Flowserve representative for additional information.
- 7.3 New equipment with seals already installed is typically shipped ready to start up, unless otherwise specified. To ensure seal integrity prior to commissioning, it is prudent to review the complete seal installation instructions with emphasis on the following procedures.
 - 7.3.1 Check all fasteners for proper engagement.
 - 7.3.2 Verify that setting plates are removed.
 - 7.3.3 Check all pipe fittings and control system connections.

8 Repairs and Guarantee

- 8.1 The Circpac HP is expected to provide reliable performance when operated within its designed operating envelope. However, repairs will be necessary when the seal reaches the end of its normal life expectancy or when it has been operated outside of its design envelope including some emergency upset events.
- 8.2 This product is a precision sealing device where the design and dimensional tolerances are critical to seal performance. Only parts supplied by Flowserve should be used to repair this seal. Unless specially arranged, Flowserve will manage repair of this seal and should be contacted as soon as a repair is required. When removing the seal, carefully reverse the procedures outlined in these instructions.
- 8.3 The Circpac HP can normally be repaired to its original condition. After inspection, a detailed quotation will be prepared for factory restoration. Upon acceptance of the quotation, the seal will be rebuilt, tested (optional), and returned to sender.
- 8.4 A guarantee is only given for original Circpac HP replacement parts and accessories delivered by Flowserve Corporation. Flowserve is not liable for damage incurred through the use of non-original replacement parts and accessories and all guarantees are rendered null and void.



TO REORDER REFER TO
B/M # _____
F.O. _____

FIS174eng REV09/2018 Printed in USA

To find your local Flowserve representative
and find out more about Flowserve Corporation,
visit www.flowserve.com

Flowserve Corporation has established industry leadership in the design and manufacture of its products. When properly selected, this Flowserve product is designed to perform its intended function safely during its useful life. However, the purchaser or user of Flowserve products should be aware that Flowserve products might be used in numerous applications under a wide variety of industrial service conditions. Although Flowserve can provide general guidelines, it cannot provide specific data and warnings for all possible applications. The purchaser/user must therefore assume the ultimate responsibility for the proper sizing and selection, installation, operation, and maintenance of Flowserve products. The purchaser/user should read and understand the Installation Instructions included with the product, and train its employees and contractors in the safe use of Flowserve products in connection with the specific application.

While the information and specifications contained in this literature are believed to be accurate, they are supplied for informative purposes only and should not be considered certified or as a guarantee of satisfactory results by reliance thereon. Nothing contained herein is to be construed as a warranty or guarantee, express or implied, regarding any matter with respect to this product. Because Flowserve is continually improving and upgrading its product design, the specifications, dimensions and information contained herein are subject to change without notice. Should any question arise concerning these provisions, the purchaser/user should contact Flowserve Corporation at any one of its worldwide operations or offices.

© Flowserve Corporation (2011)

USA and Canada

Kalamazoo, Michigan USA
Telephone: 1 269 381 2650
Telefax: 1 269 382 8726

Europe, Middle East, Africa

Etten-Leur, the Netherlands
Telephone: 31 765 028 200
Telefax: 31 765 028 487

Asia Pacific

Singapore
Telephone: 65 6544 6800
Telefax: 65 6214 0541

Latin America

Mexico City
Telephone: 52 55 5567 7170
Telefax: 52 55 5567 4224