

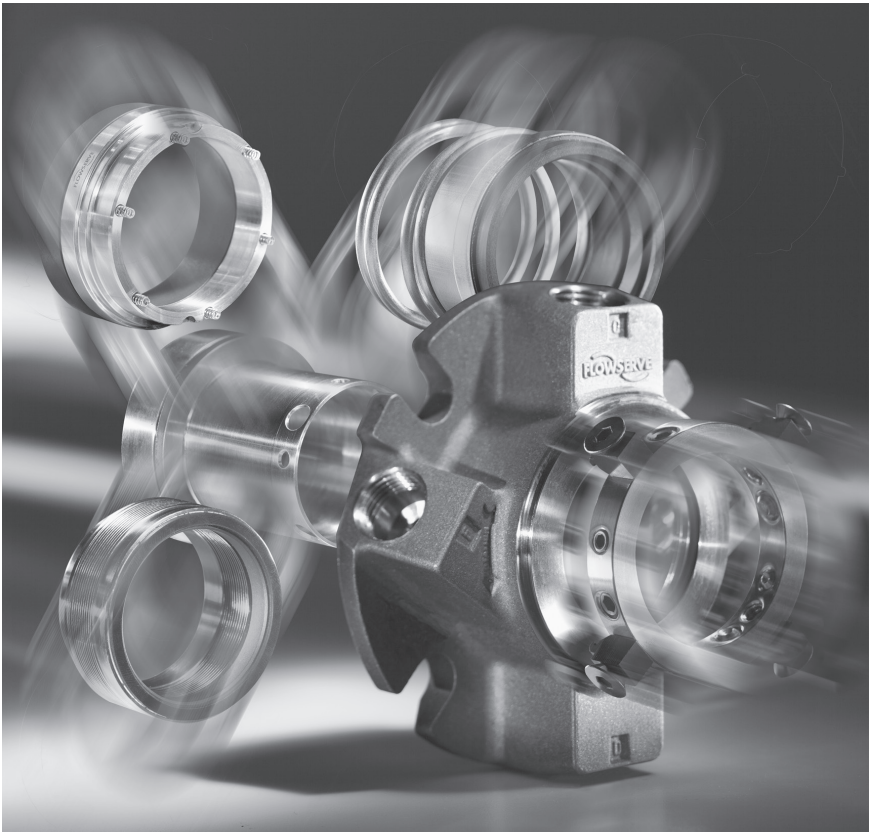

Installation Instructions

ISC Series

Innovative Standard Cartridge seal designed for ANSI and general purpose applications with maximum interchangeability between designs.



Description

This ISC seal is a cartridge mounted mechanical seal, designed for ease of installation and reliable operation. **No seal setting dimensions are required.** Removable setting devices provide proper alignment.

The ISC seal family consists of:

ISC1PX - Single Pusher Seal stationary springs

ISC2PP - Dual Pusher Seal stationary springs

ISC1BX - Single Metal Bellows Seal rotating bellows (standard)

ISC2BB - Dual Metal Bellows Seal rotating bellows (standard)

ISC1SX - Single Metal Bellows Seal stationary bellows (optional)

ISC2SS - Dual Metal Bellows Seal stationary bellows (optional)

ISC1EX - Single Elastomer Bellows Seal

The flexible stator pusher design compensates for inadvertent misalignment of the seal chamber face. Multiple springs provide uniform face loading and are external of the process fluid, resisting clogging and stress corrosion.

The bellows design is available in both rotating and stationary bellows arrangements.

Rotating bellows arrangements are used when the self cleaning feature is required and stationary bellows are used to compensate for inadvertent misalignment of the seal chamber face.

Installation according to the following steps will assure long trouble free life of the seal.

1 Equipment Check

- 1.1 **Follow plant safety regulations** prior to equipment disassembly:
 - lock out motor and valves.
 - wear designated personal safety equipment.
 - relieve any pressure in the system.
 - consult plant MSDS files for hazardous material regulations.
- 1.2 **Disassemble equipment** in accordance with equipment manufacturer's instructions to allow access to seal installation area.
- 1.3 **Remove existing mechanical seal and gland** or compression packing and packing gland.

The images of parts shown in these instructions may differ visually from the actual parts due to manufacturing processes that do not affect the part function or quality.

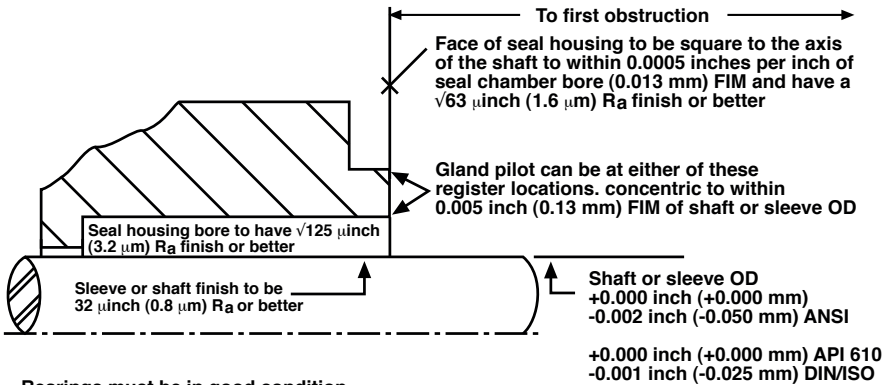

- Bearings must be in good condition
- Maximum lateral or axial movement of shaft (end play) = 0.010 inch (0.25 mm) FIM
- Maximum shaft runout at face of seal housing = 0.002 inch (0.05 mm) FIM

If the pump condition exceeds the above criteria (including consideration for thermal growth), consult Flowserve Application Engineering for recommendations to avoid seal performance compromises.

- 1.4 Make sure the shaft or sleeve and the **seal housing face are clean** and free of burrs, cuts, dents, or corrosion that might cause leakage past the sleeve gasket or gland gasket. Replace worn shaft or sleeve. **Remove sharp edges** from keyways and threads.
- 1.5 **Check equipment dimensions** to ensure that they are within the specifications shown in **Figures 1 and 2**. Critical dimensions from Figure 2 include:
 - Box Bore ($\varnothing C$)
 - Box Depth (G)(Q)
 - Distance to First Obstruction (K)
 - Pump Frame accommodates Gland OD ($\varnothing E$)
- 1.6 **Check gland bolting** to ensure the bolt diameter and bolt circle conform to the dimensions shown in Figure 2. Check gland bolt length to ensure adequate thread engagement for the actual seal gland.
- 1.7 **Check gland bolt length** to ensure adequate thread engagement for the actual seal gland. Gland dimensions are provided in the drawing that accompanied the seal.
- 1.8 **Handle the ISC with care**, it is manufactured to precise tolerances. The sealing faces of the ISC seal are the rotating and stationary faces. They are lapped flat to within three helium light bands (34.8 millionths of an inch). Keep the seal faces perfectly **clean at all times**.

ISC1PX
Single Pusher

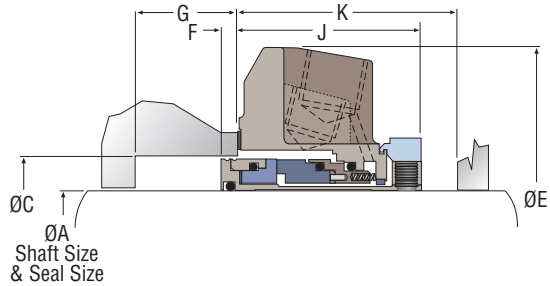

ISC1BX
Single Metal Bellows

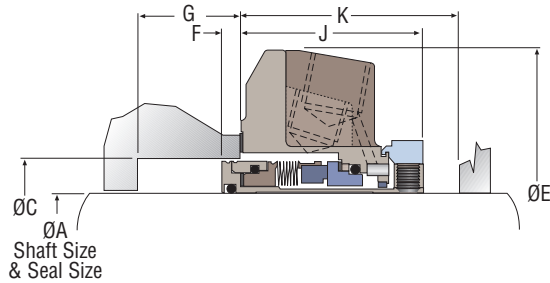

All Dimensions millimeter

A	C		E	F	G	J	K	L	M
Shaft & Seal Size	Box Bore (Min)	Box Bore (Max)	Gland OD (Min)	Seal Depth	Box Depth (Min)	Seal Extension	Dist. to Obst. Dia.	Bolt Circle	Bolt Slot
25	41.28	47.50	93.7 - 95.3	5.38	6.96	48.59	50.17	69.85	11.18
28	44.45	50.80	93.7 - 95.3	5.38	6.96	48.59	50.17	73.03	11.18
30	48.01	57.02	106.4 - 108.0	5.38	6.96	48.59	50.17	79.38	14.27
33	50.80	60.33	109.7 - 111.3	5.38	6.96	48.59	50.17	82.55	14.27
35	50.80	60.33	109.7 - 111.3	5.38	6.96	48.59	50.17	82.55	14.27
38	57.15	64.14	119.1 - 120.7	5.38	6.96	50.11	51.69	95.25	14.27
40	60.33	70.61	119.1 - 120.7	5.13	6.71	50.11	51.69	95.25	14.27
43	63.50	73.03	125.5 - 127.0	5.13	6.71	50.11	51.69	98.43	14.27
45	66.68	73.03	125.5 - 127.0	5.13	6.71	50.11	51.69	98.43	14.27
48	67.06	73.41	136.4 - 137.9	5.13	6.71	50.11	51.69	97.99	14.27
50	69.85	76.96	127.0 - 130.0	5.13	6.71	50.11	51.69	104.65	17.48
53	73.03	79.38	150.9 - 152.4	5.13	6.71	50.11	51.69	112.78	19.05
55	79.38	93.65	160.5 - 162.1	5.13	6.71	50.11	51.69	123.83	19.05
60	79.38	94.62	160.5 - 162.1	5.13	6.71	50.11	51.69	123.83	19.05
65	89.92	98.81	179.5 - 181.0	1.93	3.51	53.42	54.99	127.00	17.48
70	95.25	109.52	182.6 - 184.2	5.18	6.76	69.24	70.82	142.88	22.35

ISC2BB
Dual Metal Bellows

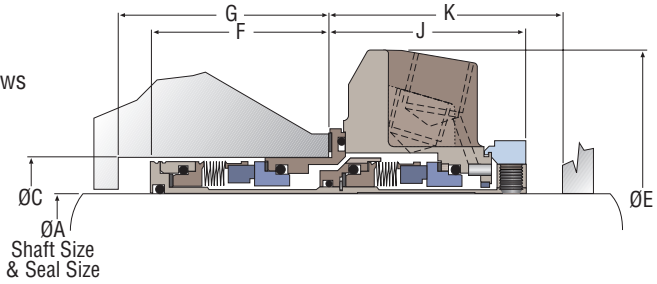

ISC2PP
Dual Pusher

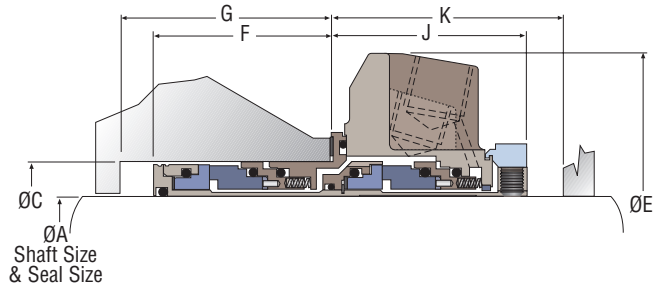

Slotted Gland Detail

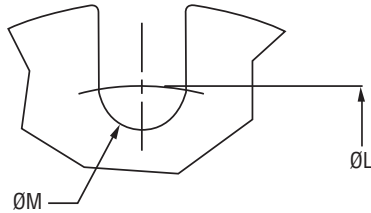

A	C	E	F	G	J	K	L	M
Shaft & Seal Size	Box Bore (Min) (Max)	Gland OD (Min)	Seal Depth	Box Depth (Min)	Seal Extension	Dist. to Obst. Dia.	Bolt Circle	Bolt Slot
25	41.28 47.50	93.7 - 95.3	46.69	48.26	52.37	53.95	69.85	11.18
28	44.45 50.80	93.7 - 95.3	46.69	48.26	52.37	53.95	73.03	11.18
30	48.01 57.02	106.4 - 108.0	46.69	48.26	52.37	53.95	79.38	14.27
33	50.80 60.33	109.7 - 111.3	46.69	48.26	52.37	53.95	82.55	14.27
35	50.80 60.33	109.7 - 111.3	46.69	48.26	52.37	53.95	82.55	14.27
38	57.15 64.14	119.1 - 120.7	48.34	49.91	53.90	55.47	95.25	14.27
40	60.33 70.61	119.1 - 120.7	48.34	49.91	53.90	55.47	95.25	14.27
43	63.50 73.03	125.5 - 127.0	48.34	49.91	53.90	55.47	98.43	14.27
45	66.68 73.03	125.5 - 127.0	48.34	49.91	53.90	55.47	98.43	14.27
48	67.06 73.41	136.4 - 137.9	48.34	49.91	53.90	55.47	97.99	14.27
50	69.85 76.96	127.0 - 130.0	48.34	49.91	53.90	55.47	104.65	17.48
53	73.03 79.38	150.9 - 152.4	48.34	49.91	53.90	55.47	112.78	19.05
55	79.38 93.65	160.5 - 162.1	48.34	49.91	53.90	55.47	123.83	19.05
60	79.38 94.62	160.5 - 162.1	48.34	49.91	53.90	55.47	123.83	19.05
65	89.92 98.81	179.5 - 181.0	45.06	46.63	57.20	58.78	127.00	17.48
70	95.25 109.52	182.6 - 184.2	61.70	63.27	73.81	75.39	142.88	22.35

ISC Dimensional Data

ISC1PX
Single Pusher

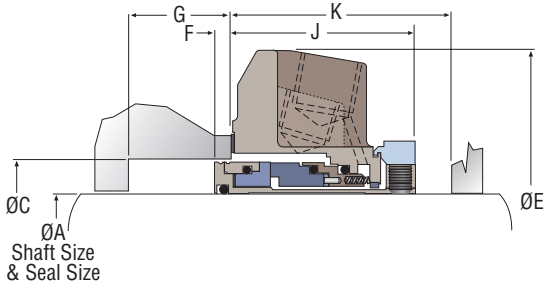

ISC1BX
Single Metal Bellows

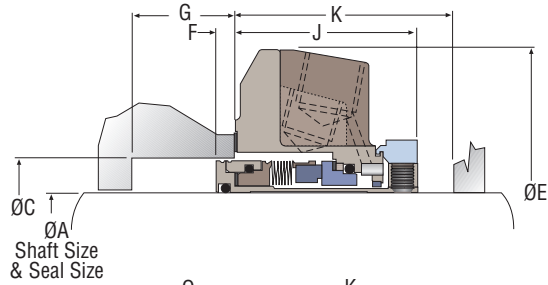

ISC1EX
Single Elastomer Bellows*

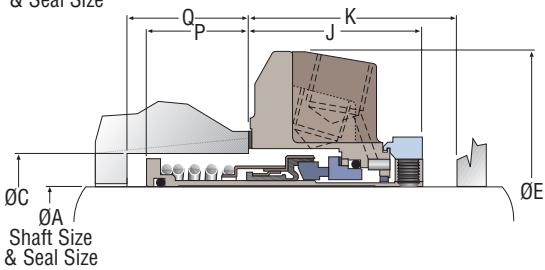

All Dimensions inch

A	C	E	F	G	J	K	L	M	P*	Q*
Shaft & Seal Size	Box Bore (Min) (Max)	Gland OD	Seal Depth	Box Depth (Min)	Seal Extension	Dist. to Obst. (Min)	Bolt Circle	Bolt Slot Dia.	Seal Depth	Box Depth (Min)
1.000	1.625 1.875	3.69 - 3.75	0.212	0.274	1.913	1.975	2.750	0.440	0.812	0.874
1.125	1.750 2.000	3.69 - 3.75	0.212	0.274	1.913	1.975	2.875	0.440	0.962	1.024
1.250	1.890 2.245	4.19 - 4.25	0.212	0.274	1.913	1.975	3.125	0.562	N/A	N/A
1.375	2.000 2.375	4.32 - 4.38	0.212	0.264	1.913	1.975	3.250	0.440	1.127	1.189
1.437	2.250 2.688	4.72 - 4.78	0.222	0.284	1.958	2.020	3.750	0.560	N/A	N/A
1.500	2.250 2.525	4.69 - 4.75	0.202	0.264	1.973	2.035	3.750	0.560	1.152	1.214
1.625	2.375 2.780	4.69 - 4.75	0.202	0.264	1.973	2.035	3.750	0.560	1.152	1.214
1.750	2.500 2.875	4.94 - 5.00	0.202	0.264	1.973	2.035	3.875	0.560	1.152	1.214
1.875	2.625 2.875	4.94 - 5.00	0.202	0.264	1.973	2.035	3.875	0.560	1.153	1.214
1.937	2.750 3.030	5.09 - 5.15	0.202	0.264	1.973	2.035	4.120	0.688	N/A	N/A
2.000	2.750 3.030	5.09 - 5.15	0.202	0.264	1.973	2.035	4.120	0.688	1.152	1.214
2.125	2.875 3.125	5.94 - 6.00	0.202	0.264	1.973	2.035	4.440	0.750	1.092	1.154
2.250	3.000 3.318	5.94 - 6.00	0.206	0.268	1.973	2.035	4.440	0.750	N/A	N/A
2.375	3.125 3.687	6.32 - 6.38	0.202	0.264	1.973	2.035	4.875	0.750	1.287	1.349
2.437	3.375 3.687	6.32 - 6.38	0.233	0.295	1.942	2.004	4.875	0.750	N/A	N/A
2.500	3.375 3.687	6.32 - 6.38	0.202	0.264	1.973	2.035	4.875	0.750	1.287	1.349
2.625	3.625 4.312	7.19 - 7.25	0.204	0.266	2.726	2.788	5.625	0.880	1.129	1.191
2.750	3.750 4.312	7.19 - 7.25	0.204	0.266	2.726	2.788	5.625	0.880	1.129	1.191

*Dimensional items P & Q refer to Single Elastomer Bellows only

ISC2PP
Dual Pusher

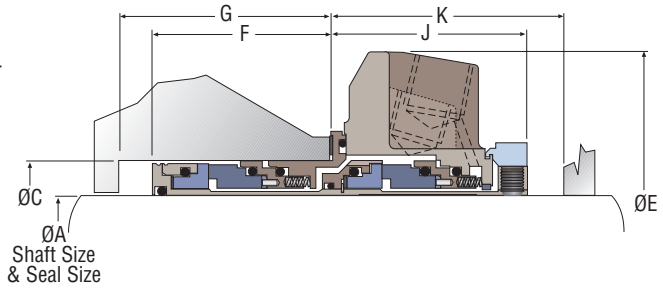

ISC2BB
Dual Metal Bellows

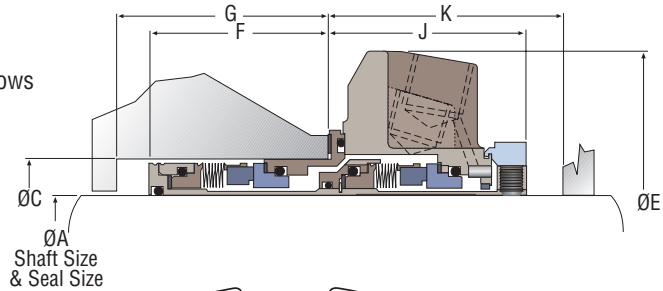

Slotted Gland Detail

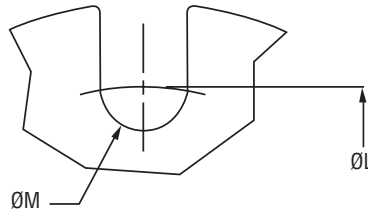

A	C		E	F	G	J	K	L	M
Shaft & Seal Size	Box Bore		Gland OD	Seal Depth	Box Depth (Min)	Seal Extension	Dist. to Obst. (Min)	Boit Circle	Slot Dia.
	(Min)	(Max)							
1.000	1.625	1.875	3.69 - 3.75	1.838	1.900	2.062	2.124	2.750	0.440
1.125	1.750	2.000	3.69 - 3.75	1.838	1.900	2.062	2.124	2.875	0.440
1.250	1.890	2.245	4.19 - 4.25	1.838	1.900	2.062	2.124	3.125	0.562
1.375	2.000	2.375	4.32 - 4.38	1.838	1.900	2.062	2.124	3.250	0.440
1.437	2.250	2.688	4.72 - 4.78	1.903	1.965	2.122	2.184	3.750	0.560
1.500	2.250	2.525	4.69 - 4.75	1.903	1.965	2.122	2.184	3.750	0.560
1.625	2.375	2.780	4.69 - 4.75	1.903	1.965	2.122	2.184	3.750	0.560
1.750	2.500	2.875	4.94 - 5.00	1.903	1.965	2.122	2.184	3.875	0.560
1.875	2.625	2.875	4.94 - 5.00	1.903	1.965	2.122	2.184	3.875	0.560
1.937	2.750	2.030	5.09 - 5.15	1.903	1.965	2.122	2.184	4.120	0.688
2.000	2.750	3.030	5.09 - 5.15	1.903	1.965	2.122	2.184	4.120	0.688
2.125	2.875	3.125	5.94 - 6.00	1.903	1.965	2.122	2.184	4.440	0.750
2.250	3.000	3.318	5.94 - 6.00	1.903	1.965	2.122	2.184	4.400	0.750
2.375	3.125	3.687	6.32 - 6.38	1.903	1.965	2.122	2.184	4.875	0.750
2.437	3.375	3.687	6.32 - 6.38	1.934	1.996	2.091	2.153	4.875	0.750
2.500	3.375	3.687	6.32 - 6.38	1.903	1.965	2.122	2.184	4.875	0.750
2.625	3.625	4.312	7.19 - 7.25	2.429	2.491	2.906	2.968	5.625	0.880
2.750	3.750	4.312	7.19 - 7.25	2.429	2.491	2.906	2.968	5.625	0.880

2 ISC Installation - Single Seal Design

Note: No seal setting measurements are needed to install the seal. Instructions are for vertically split case end-suction ANSI pumps. Modification of the procedure may be required for other style pumps. Consult Flowserve.

2.1 Tools needed for installation:

- An open end wrench for the gland bolt nuts
- 1/8" Allen wrench (provided)
- 3/16" Allen wrench (provided) for sizes >60 mm (>2.500")

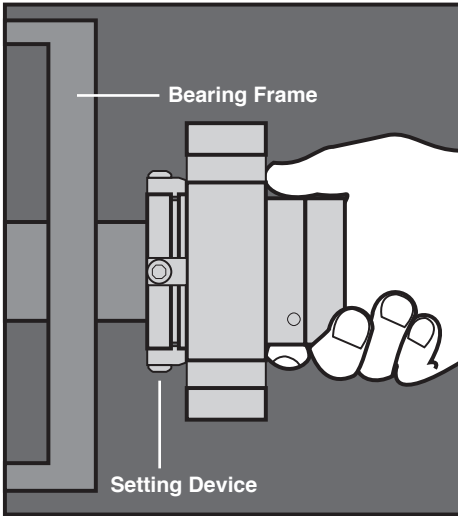

2.2 **Lubricate the shaft** or sleeve lightly with silicone lubricant unless otherwise specified.

2.3 Tighten the setting device cap screws

2.4 **Install the complete ISC cartridge assembly** onto the shaft or sleeve with the setting devices near the bearing housing. See Figure 3.

Figure 3

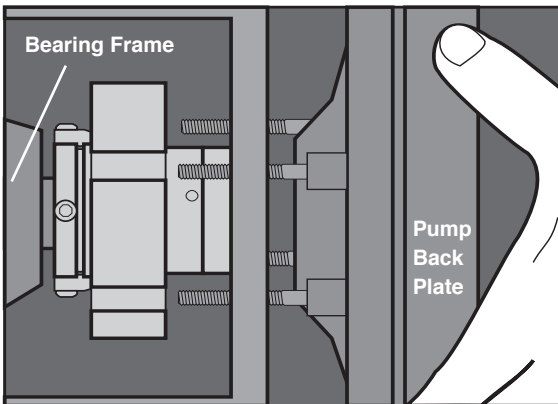

2.5 **Install the pump back plate** (seal chamber) and bolt it in place on the bearing frame. See Figure 4.

Figure 4

2.5 **Position the ISC** with the gland tight against the seal chamber face. If equipment conditions allow, position gland with the outlet port or plugged flush port as close to the 12:00 o'clock position as possible. See Sections 3 and 4 for further piping considerations. Otherwise turn the gland so that the vent tap is as close to the 12:00 o'clock position as possible and so that the flush piping will clear the bearing frame.

Caution: Setting devices should not be removed or loosened before tightening the gland bolts and tightening the set screws to the shaft.

Tighten the gland nuts evenly in a diagonal sequence. Do not over tighten the gland nuts, as this can warp seal parts and cause leakage. Confirm adequate thread engagement before final torque setting.

The suggested ISC minimum torque values are as follows for seals with these shaft sizes (in inches):

15 ft-lbs (20 N-m)	20 ft-lbs (27 N-m)
1.000	2.125
to	to
2.000	2.750

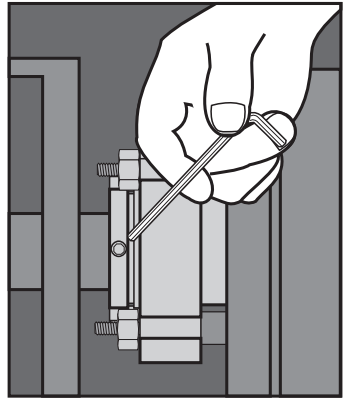

Figure 5

2.6 **Assemble the pump.** Avoid pipe strain. Align coupling properly.

2.7 With the impeller, shaft, coupling, and bearings in their final operating positions, **tighten the drive collar set screws.** See Figure 5.

Suggested minimum torque values for set screws are as follows:

Shaft Sizes 25 - 60 mm (1.000 - 2.500 inches)
 $\frac{1}{4}$ " 4.5 N-m (40 inch-lbs)

Shaft Sizes 67 - 70 mm (2.625 - 2.750 inches)
 $\frac{3}{8}$ " 13.6 N-m (120 inch-lbs)

2.8 **Caution: Remove the setting devices** from the drive collar. See Figure 6. Save these and the fasteners for future use when the pump impeller is reset or when the seal is removed for repairs.

2.9 **Turn the shaft** by hand to ensure unobstructed operation.

2.10 See **Operational Recommendations** before start-up.

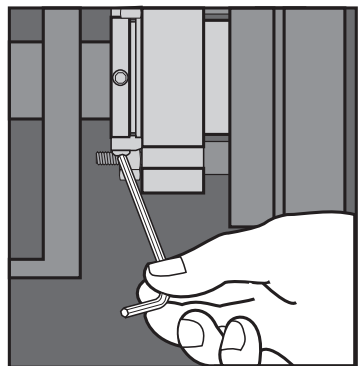
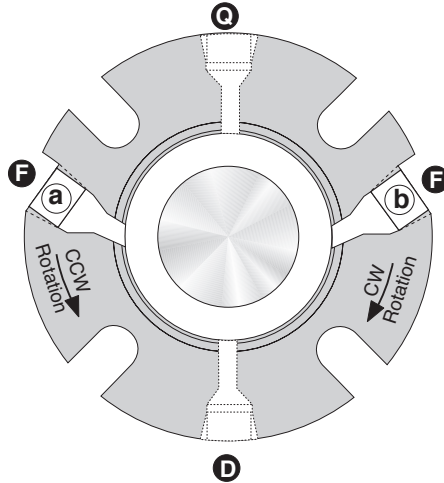

Figure 6

3 Single Seal Piping and Operational Recommendation

- 3.1 Install an **adequate seal flush** system. The ISC requires a clean cool environment for maximum seal life. With a clean cool product, use a bypass flush from the pump discharge (piping plan 11*) or a bypass flush to the pump suction (piping plan 13). With clean hot products use a bypass flush through a cooler (piping plan 21). With abrasive products or products that are incompatible with the seal, use a flush from a clean external source (piping plan 32).

***Note:** All piping plan designations used in these instructions are from API 682. for the corresponding ASME B73 piping plan designation, please add a "73" in front of the referenced piping plan.



Shaft rotation from exposed end of gland

Figure 7

For Piping Plans 11, 21 and 32:

<u>Shaft Rotation (from exposed end of gland)</u>	<u>Inlet</u>	<u>Plugged Port</u>
Clockwise (CW)	Port (b)	Port (a)
Counterclockwise (CCW)	Port (a)	Port (b)

For Piping Plan 13:

<u>Shaft Rotation (from exposed end of gland)</u>	<u>Outlet</u>	<u>Plugged Port</u>
Clockwise (CW)	Port (a)	Port (b)
Counterclockwise (CCW)	Port (b)	Port (a)

- 3.2 Use flush port that coincides with gland markings and direction of equipment rotation. Plug extra NPT opposite of flush. See Figure 7.
- 3.3 Taps **C** and **D** in the gland are quench and drain ports used for fluid quenching, flush plan 62. If they are not used, they should be plugged with pipe plugs.
- 3.4 **Remove lock outs** on pump and valves.
- 3.5 Do not start up the equipment dry to check motor rotation or for any other reason. Open valves to flood pump with product fluid. Ensure that the seal flush system is operating. Vent air from the casing of the pump and the seal chamber before start-up.
- 3.6 **Observe the start-up.** If the seal runs hot or squeals, check the seal flush system. Do not allow the equipment to run for any extended time if the seal gets hot or squeals.

4 Dual Seal Piping and Operational Recommendations

- 4.1 **Flush taps **a** and **b** in the gland are barrier fluid inlet and outlet ports.** Use Figure 8 to determine which ports to use as inlet and outlet.

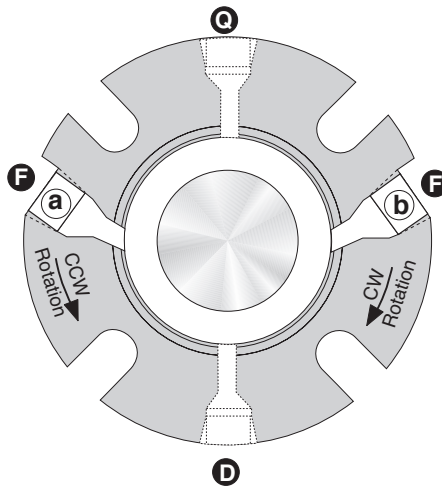

Shaft rotation from exposed end of gland

Figure 8

	Inlet	Outlet
Clockwise (CW)	Port b	Port a
Counterclockwise (CCW)	Port a	Port b

- 4.2 For **dual pressurized seal (double seal)** operation, supply a clean compatible barrier fluid to the inlet port at a pressure at least 170 kPa (25 psi) above the seal chamber pressure. See Figure 9. The pressure of the barrier fluid must not exceed the recommended maximum pressure. Flowserve can supply information on barrier fluid flow requirements based on seal size, product temperature, barrier fluid characteristics, and shaft speed.
- 4.3 For **dual unpressurized (tandem seal)** operation, supply a clean compatible buffer fluid to the inlet port at a pressure below the seal chamber pressure. See Figure 10. The pressure in the seal chamber must not exceed the recommended maximum pressure. Flowserve can supply information on buffer fluid flow requirements based on seal size, product temperature, buffer fluid characteristics, and shaft speed.

Double ISC with Supply Tank

Figure 9

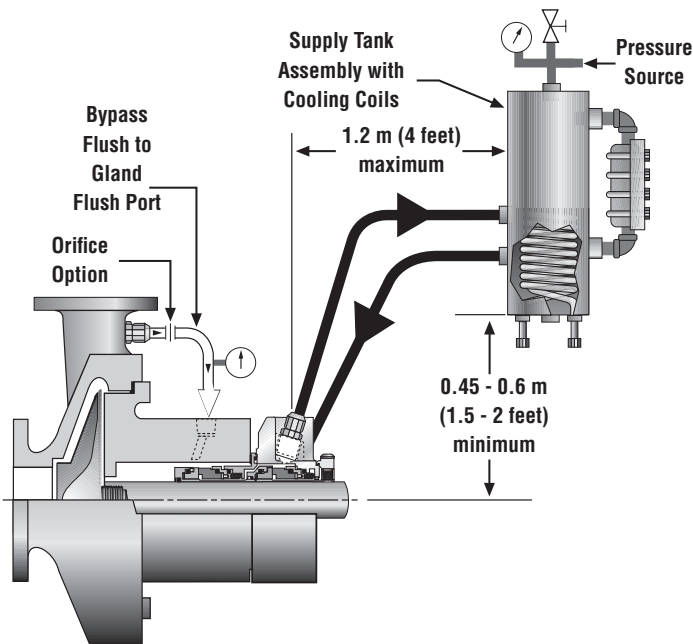

4.4 The **Flowserve Supply Tank** is designed to work with the ISC Dual Seal to form a self-contained sealing system. The new circulating feature in the ISC provides a positive barrier fluid flow from the seal cavity to the Supply Tank and back to the seal. In most cases the natural cooling of the piping and tank are adequate to remove seal generated heat. Cooling coils are available with the Supply Tank to increase heat dissipation. The Supply Tank can be used with the ISC dual seal in both the dual pressurized or dual unpressurized operating modes.

Recommendation: For enhanced seal performance and reduced coking, use **DuraClear** as a barrier fluid. Refer to DuraClear brochure FSD123 or contact a Flowserve seal application engineer for further details.

Tandem ISC with Supply Tank

Figure 10

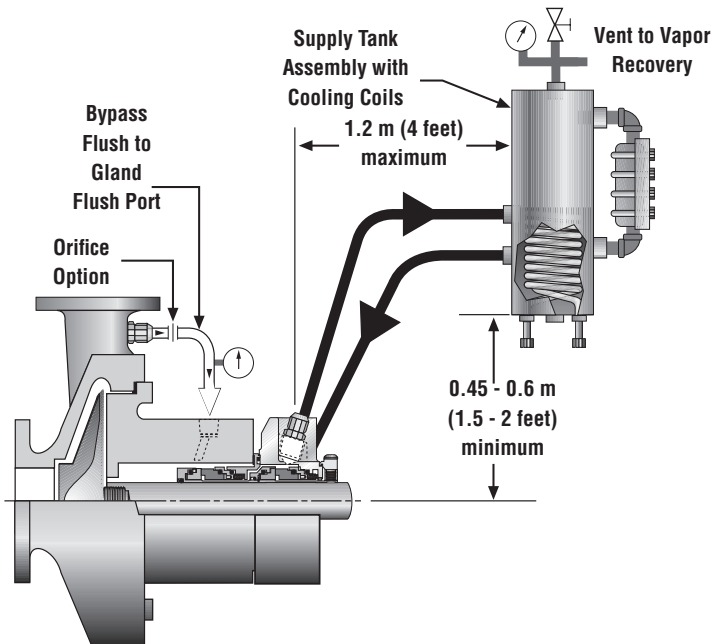

5 Operational Recommendations

- 5.1 **Do not exceed corrosion limits.** The ISC is designed to resist corrosion by most chemicals. However, do not expose the ISC materials of construction to products outside of their corrosion limits. The ISC assembly drawing lists the materials of construction. Consult Flowserve for chemical resistance recommendations.
- 5.2 **Do not exceed the recommended maximum pressure and speed limits** shown in the ISC brochure.
- 5.3 **Do not exceed the temperature limits** of the ISC. The materials of construction are listed on the ISC assembly drawing. For dual seals using supply tanks with cooling coils, turn on cooling water to the supply tank before start-up.
- 5.4 **Do not start up or run the ISC dry.** Buffer/barrier fluid must be in the seal cavity for dual seals at all times during pump operation. Process fluid must be in the pump volute at all times during single seal operation.

6 Repairs

This product is a precision sealing device. The design and dimension tolerances are critical to seal performance. Only parts supplied by Flowserve should be used to repair a seal. To order replacement parts, refer to the part code and B/M number. A spare backup seal should be stocked to reduce repair time.

When seals are returned to Flowserve for repair, **decontaminate the seal assembly** and include an order marked "**Repair or Replace.**" **A signed certificate of decontamination** must be attached. **A Material Safety Data Sheet (MSDS) must be enclosed** for any product that came in contact with the seal. The seal assembly will be inspected and, if repairable, it will be rebuilt, tested, and returned.



TO REORDER REFER TO
B/M # _____
F.O. _____

FIS120eng REV 09/2018 Printed in USA

To find your local Flowserve representative
and find out more about Flowserve Corporation,
visit www.flowserve.com

Flowserve Corporation has established industry leadership in the design and manufacture of its products. When properly selected, this Flowserve product is designed to perform its intended function safely during its useful life. However, the purchaser or user of Flowserve products should be aware that Flowserve products might be used in numerous applications under a wide variety of industrial service conditions. Although Flowserve can provide general guidelines, it cannot provide specific data and warnings for all possible applications. The purchaser/user must therefore assume the ultimate responsibility for the proper sizing and selection, installation, operation, and maintenance of Flowserve products. The purchaser/user should read and understand the Installation Instructions included with the product, and train its employees and contractors in the safe use of Flowserve products in connection with the specific application.

While the information and specifications contained in this literature are believed to be accurate, they are supplied for informative purposes only and should not be considered certified or as a guarantee of satisfactory results by reliance thereon. Nothing contained herein is to be construed as a warranty or guarantee, express or implied, regarding any matter with respect to this product. Because Flowserve is continually improving and upgrading its product design, the specifications, dimensions and information contained herein are subject to change without notice. Should any question arise concerning these provisions, the purchaser/user should contact Flowserve Corporation at any one of its worldwide operations or offices.

© 2012 Flowserve Corporation

USA and Canada

Kalamazoo, Michigan USA
Telephone: 1 269 381 2650
Telefax: 1 269 382 8726

Europe, Middle East, Africa

Etten-Leur, the Netherlands
Telephone: 31 765 028 200
Telefax: 31 765 028 487

Asia Pacific

Singapore
Telephone: 65 6544 6800
Telefax: 65 6214 0541

Latin America

Mexico City
Telephone: 52 55 5567 7170
Telefax: 52 55 5567 4224