



# ***Australia & New Zealand Quick Response Centers***

Maintenance and Repair • On-Site Services  
Parts and Components • Pump Retrofits and Upgrades



***Experience In Motion***



## **Repair, Service and Technical Support for Australia & New Zealand**

*The Flowserve Australia & New Zealand Quick Response Centers (QRC) focus on providing customers with uncompromising service and support.*

*The Australia & New Zealand QRC's are staffed by highly skilled engineers and technicians who are available around the clock, seven days a week to respond to customer queries, troubleshoot problems and provide reliable solutions.*

### **Strength of Experience, Commitment to Excellence**

The Australia & New Zealand QRC's serve customers from industries requiring superior equipment performance and service life, such as:

- Oil and gas production
- Hydrocarbon processing
- Chemical processing
- Water resources
- Power generation
- Mining and mineral processing
- Pulp and paper
- General industry
- Steel industry

### **Premier, Value-Added Service**

With unequaled pump and seal knowledge, design expertise and manufacturing capabilities, the Australia & New Zealand QRC's specialize in value-added repair services. QRC engineers and technicians service most types of equipment, including pumps, motors, compressors, agitators, valves and seals. The dynamic range of services offered by the Australia & New Zealand QRC's include:

- Maintenance, repair and inspection service
- Pump upgrades, re-rates and retrofits
- Overhaul, outage and mechanical service
- Installation and commissioning service
- On-site repair and diagnostic services
- Contract maintenance
- Parts and components supply
- Field supervision
- Service maintenance contract







## Maintenance and Repair Services

### A Dynamic Range of Capabilities

Australia & New Zealand QRC facilities feature shop and office space to support repair, engineering, sales and customer service functions. In-shop operations can handle a full range of pumps from small, single-stage overhung units to large multistage, between bearing pumps.

The Australia & New Zealand QRC facilities offer extensive services, including:

- Machining capability:
  - Manual & CNC lathes
  - Manual & CNC milling machines
  - Horizontal & vertical boring mills
  - Radial, heavy duty press & industrial press drills
  - Shaft grinders
  - Welding
  - Painting
  - Sand blasting
- Lapping capabilities:
  - lapping tables
- Repair Capabilities:
  - Repair & static pressure test of slurry & API seals
  - Repair of seals
- Testing:
  - Mag particle testing
  - API and SLC seal static pressure testing
  - Dynamic slurry seal test
  - Dynamic seal tester





## ***On-Site Services***

### ***Installation and Commissioning Service***

With limited staffing, customers often do not have the resources to supervise ongoing, equipment-related activities. As a result, field service experts from the Australia & New Zealand QRC's are available to support customer on-site requirements including:

- Equipment installation
- Start-up and commissioning
- Equipment foundation inspection
- Pipe and pump bolt-up, alignment and inspection
- Equipment removal and handling
- Equipment transportation
- Maintenance activities



### ***Overhaul, Outage and Mechanical Services***

The Australia & New Zealand QRC's have extensive experience and resources to provide integrated outage and mechanical services. Field service teams offer rapid mechanical assistance, including maintenance, upgrade and inspection services during times of high demand.





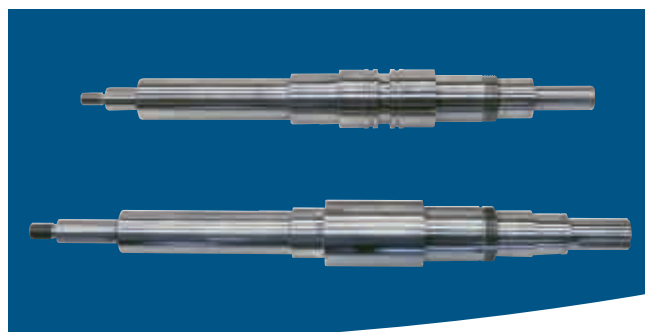

## Parts and Components

Quality parts complying to OEM specifications for the entire range of Flowserve product brands are readily available through the Australia & New Zealand QRC's. As all parts conform to original design and materials specifications, customers are ensured reliable operation and lowest equipment ownership costs.

The Australia & New Zealand QRC's can also re-engineer and produce non-Flowserve components for equipment that is obsolete or where the original equipment manufacturer cannot be located.

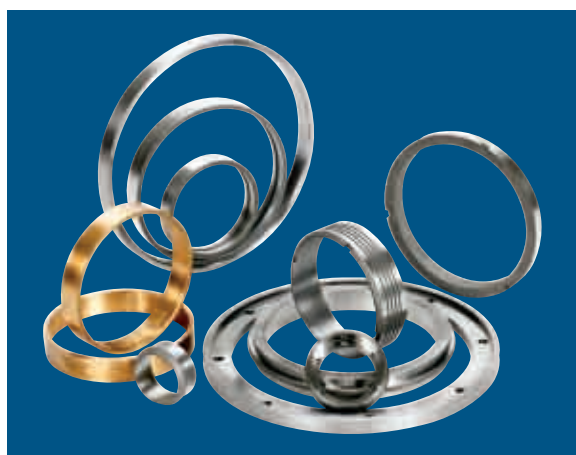

## The Flowserve Advantage

Flowserve manufactured parts offer significant benefits to customers. As an OEM, Flowserve understands the critical elements involved in designing and producing high quality parts. Whether cast or machined, Flowserve manufactured parts and components result in lower total operating costs and increased personnel safety.

- Flowserve casting quality is superior. Surface finishes, tolerances and material compositions are maintained within defined specifications.
- Flowserve parts incorporate the latest design changes which improve operating efficiency and extend equipment life.
- Customers benefit from ongoing research to develop new materials, overlay techniques and mechanically improved components.





## Upgrades, Re-rates and Retrofits

Unreliable and leaking pumps can be refurbished to "as-new" condition via a myriad of mechanical upgrade and retrofit options. Expert engineers from the Australia & New Zealand QRC facility have the experience to analyze and diagnose the root causes of mechanical pump failure and to recommend solutions that improve reliability, reduce emissions and increase plant uptime.

### Mechanical Upgrades and Retrofits

- ISO 13709/API 610 10th Edition upgrades, including the RVX and RHWX upgrades for horizontal and vertical overhung pumps, bring out-of-date process pumps to current API standards. This avoids costly new equipment investments.
- Other available mechanical upgrades, include:
  - Increased rotor stiffness (Superstraight™ shaft material)
  - Bearing housing and bearings
  - Mechanical seal upgrade to API 682
  - Seal chamber
  - Coupling
  - Wear ring

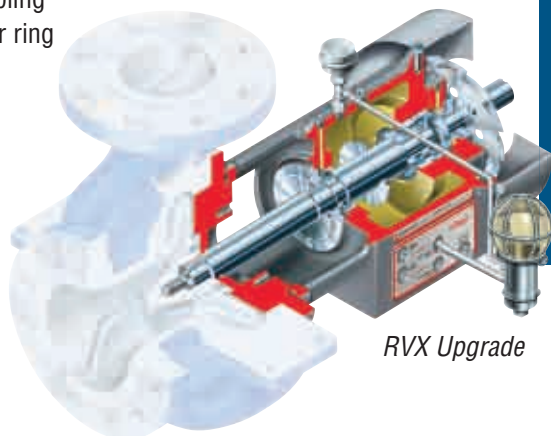

### Hydraulic Upgrades and Retrofits

Hydraulic re-rates can be provided to cover changes in flow or TDH, or increase efficiency for power savings.

- Optimization of lip and shroud clearances (A/B/C gap)
- Impeller modifications
- High-efficiency rotors
- Low flow modifications
- Re-bowling
- De-staging or upstaging
- Optimized hydraulics to reduce erosion/abrasion

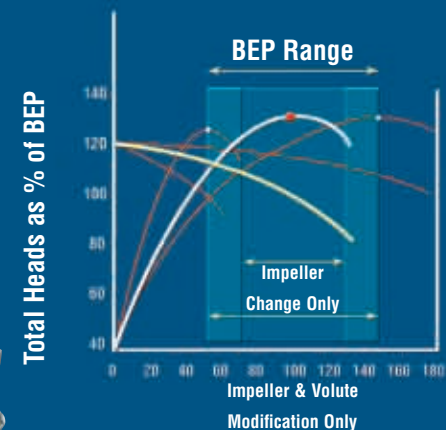

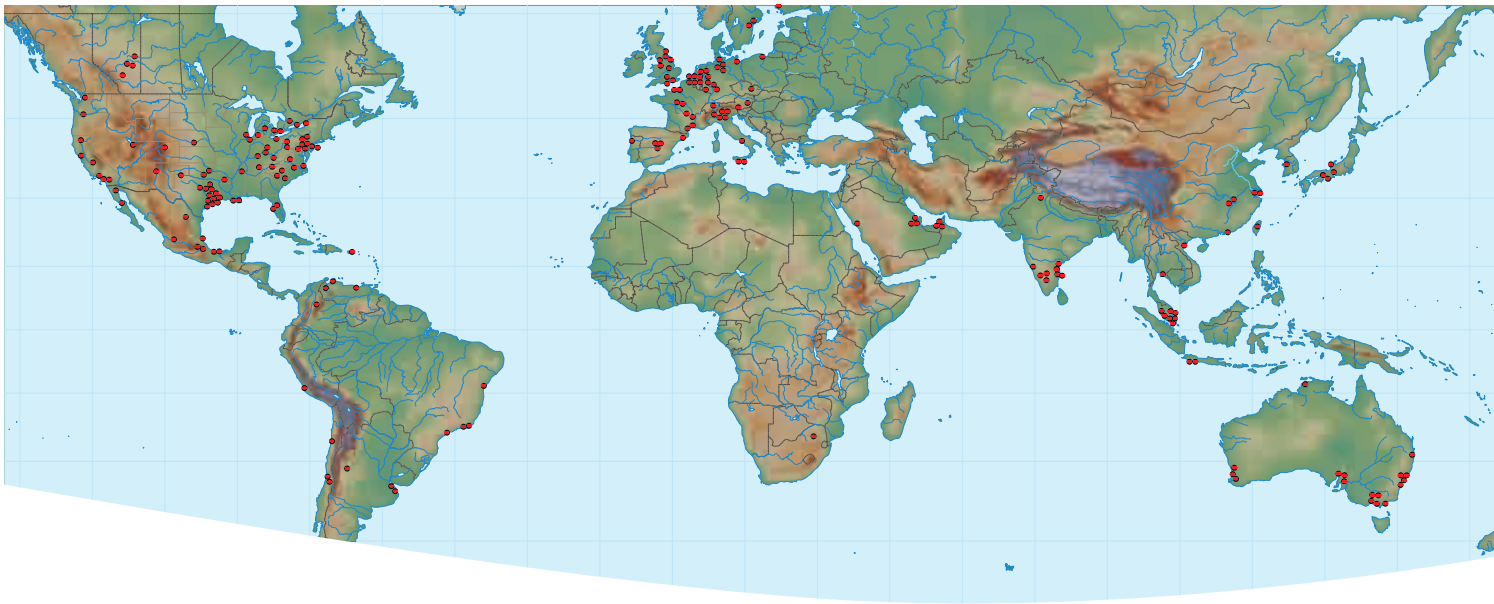

## ***Pump & Seal Supplier to the World***

With an installed base of more than one million pumps & seal, Flowserve has sales offices, service centers and manufacturing facilities throughout the world. As a result of its extensive global footprint, Flowserve is ideally positioned to deliver best-in-class solutions to successfully address the world's most challenging projects.

### ***Australia & New Zealand Quick Response Centers***





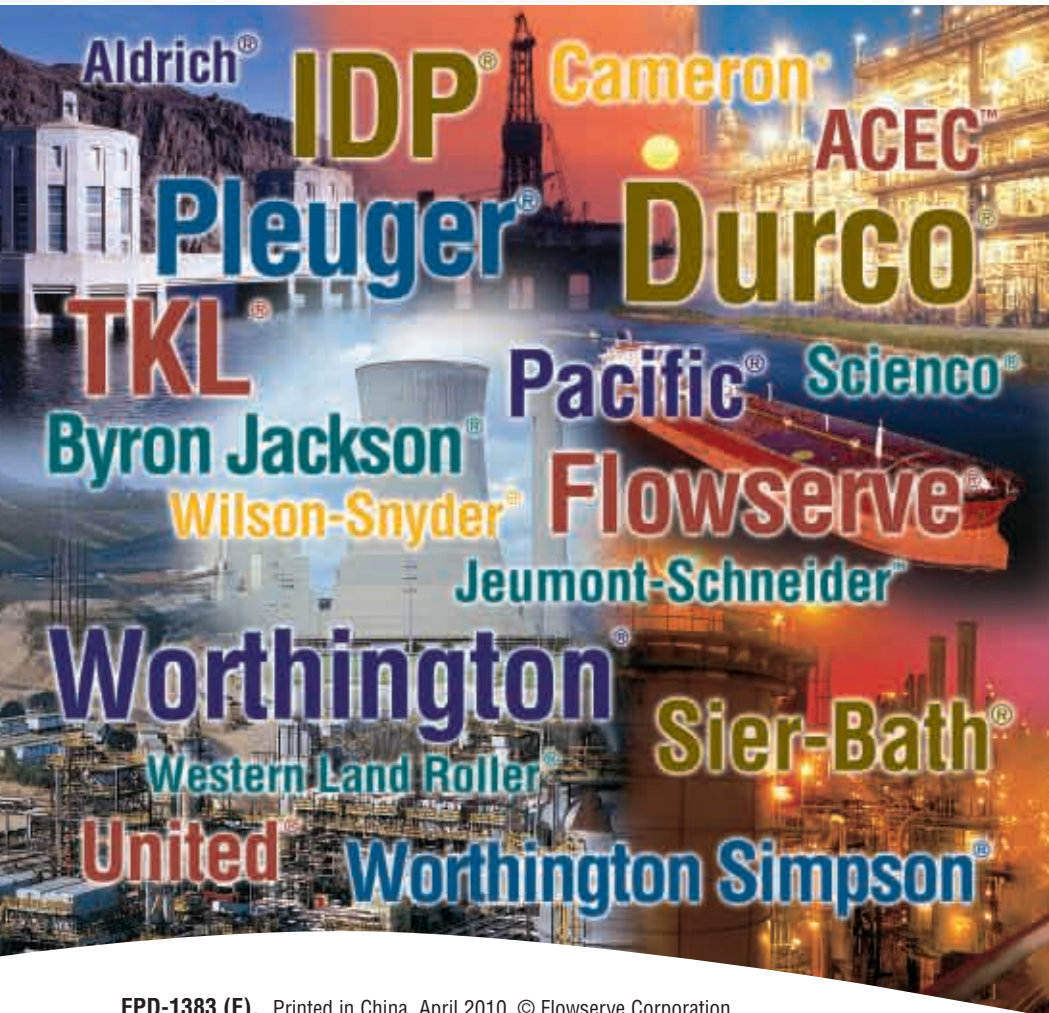

FPD-1383 (E), Printed in China. April 2010. © Flowserve Corporation

**To find your local Flowserve representative:**

For more information about Flowserve Corporation,  
visit [www.flowserve.com](http://www.flowserve.com)

**Sydney (PUMP)**

Until 1 171 - 175 Newton Rd,  
Wetherill Park, NSW 2164  
Australia  
(+61) 2 9623 3900  
(+61) 2 9673 1870

**Melbourne (PUMP)**

28 Richland Avenue Coopers  
Plains, Queensland 4108  
Australia  
(61) 7 37154122  
(61) 7 32770783

**Mulgrave (PUMP)**

Unit 5/3 Faigh Street Mulgrave VIC  
3170  
Australia  
03 9574 3174  
03 9574 3103

**South Australia (PUMP)**

17 - 19 McBryde Tce,  
Whyalla SA 5600  
Australia  
08 8645 1262  
08 8645 1053

**Perth (PUMP)**

Unit 1 29 McDowell St Welshpool,  
6106 Perth  
Australia  
08 9451 6714  
08 9458 2051

**Darwin (PUMP&SEAL)**

31 McCOURT Road,  
Yarrowona NT 0830 Darwin  
Australia  
08 8931 5222  
08 8931 5233

**Sydney (SEAL)**

8 Binney Road, Marayong NSW  
2148  
Australia  
(61-02) 88227100  
(61-02) 96797511

**Melbourne (SEAL)**

Unit 17/35 Dunlop Road,  
Mulgrave Victoria 3170  
Australia  
(61-03) 95355900  
(61-03) 95355901

**Perth (SEAL)**

55 Quill Way, Henderson WA 6166  
Australia  
(61-08) 94949200  
(61-08) 94949201

**New Zealand (SEAL)**

Auckland QRC  
23C Rennie Drive, Airport Oaks,  
Auckland 1730  
New Zealand  
(64-9) 2571270  
(64-9) 2571277

**New Zealand (PUMP)**

Christchurch QRC  
18 Hammersmith Drive  
Wigram  
Christchurch 8042  
New Zealand.  
(+64) 3434511  
(+64) 3434514