

HPX-H

ISO 13709/API 610 (OH2)

High-Pressure Horizontal Process Pump

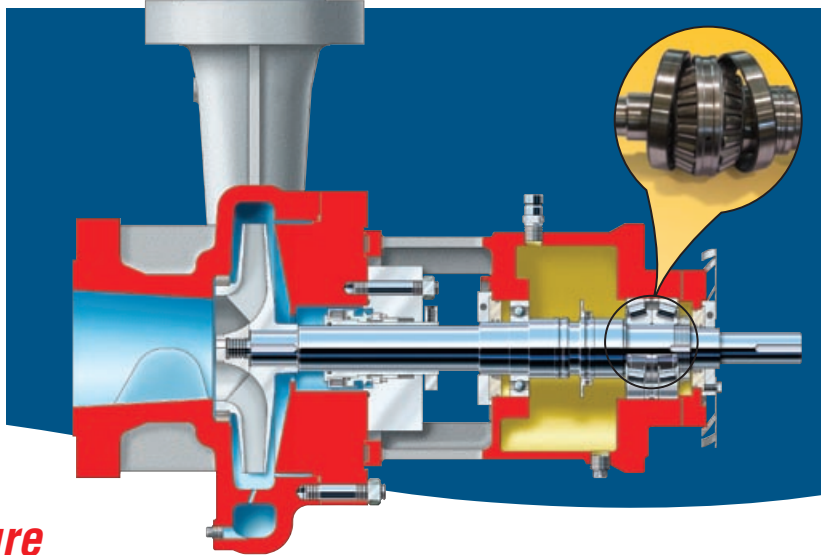
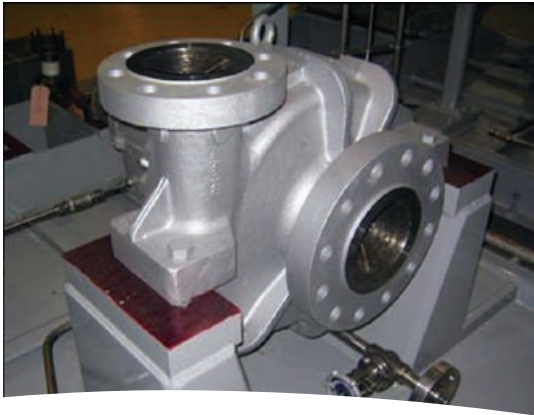

Performance Under Pressure

The new Flowserve HPX-H high-pressure horizontal process pump provides reliable operation at pressures exceeding the suction pressure and maximum allowable working pressure of its popular HPX process pump. Incorporating the HPX's proven hydraulics, the HPX-H is capable of handling pressures up to 150 bar (2175 psi). It employs an optimized thrust impeller configuration and tapered roller thrust bearings to meet high-suction pressure needs. Available with Class 600, 900 and 1500 flanges to ASME B16.5, the HPX-H meets or exceeds the rigorous requirements of ISO 13709/API 610 and ISO 21049/API 682, latest editions.

Typical High-Pressure Applications

- Petrochemical processing
- Chemical processing
- Boiler feed water circulation
- Reverse osmosis booster
- GTL processes

Features and Benefits

High Axial Thrust Rotor Design boasts low L^3/D^4 shaft stiffness ratio, resulting in long rotor, bearing and mechanical seal life. Featuring duplex single row tapered roller thrust bearings and an optimized thrust impeller configuration, this rotor design capably handles suction pressures up to 75 bar (1088 psi)

Heavy-Duty Centerline Supported Casing with extra thick walls and flanges carries a higher pressure rating than standard designs and exceeds ISO 13709/API 610 nozzle loading requirements. It also facilitates shaft alignment at temperatures up to 450°C (850°F). Top/top nozzle configuration optional. Raised face flanges are to ASME B16.5; ISO, JIS and DIN flanges available

Robust Bearing System consists of duplex single row, tapered roller thrust bearings and a single row deep groove ball radial bearing. Oil slinger lubrication and labyrinth bearing enclosures are standard. Heat sink flinger and external fan sufficiently cool the pump to enable pumping temperatures to 450°C (850°F) without the need for water cooling. Pure oil mist, purge oil mist and water cooling optional

Standard ISO 21049/API 682 Seal Chamber houses single and dual mechanical seals as well as numerous high-pressure designs

Operating Parameters

- Flows to 1500 m³/h (6600 US gpm)
- Heads to 300 m (985 ft)
- Maximum working pressures to:
 - 100 bar (1450 psi) with Class 600 and 900 flanges
 - 150 bar (2175 psi) with Class 1500 flanges
- Temperatures to 450°C (850°F)
- More than 25 sizes with discharge nozzles ranging from 25 mm (1 in) to 355 mm (14 in)

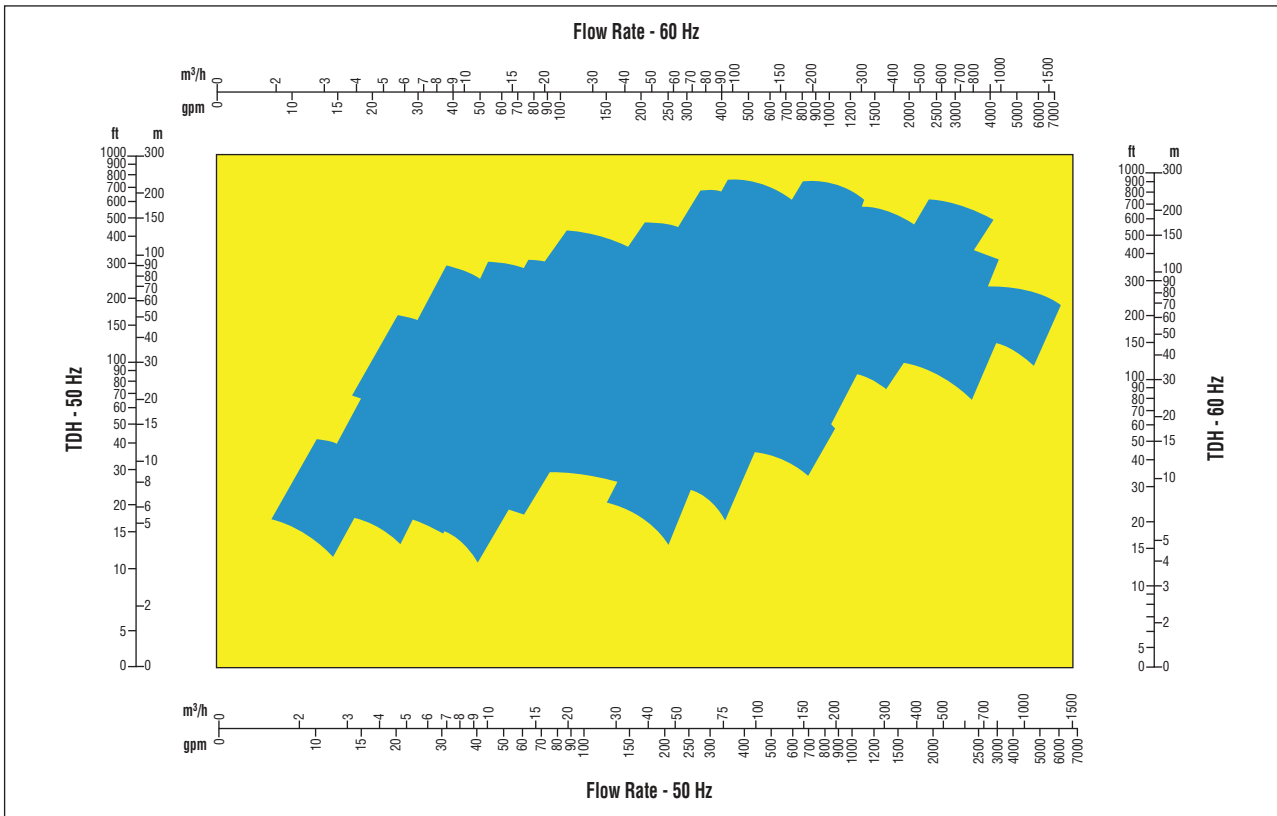

Bulletin PSS-10-5.3 (E/A4) Printed in USA. October 2007.

© Flowserve Corporation

To find your local Flowserve representative:

For more information about Flowserve Corporation, visit www.flowserve.com or call USA 1 800 728 PUMP (7867)

USA and Canada

Flowserve Corporation
5215 North O'Connor Blvd.
Suite 2300
Irving, Texas 75039-5421 USA
Telephone: 1 937 890 5839

Europe, Middle East, Africa

Flowserve Corporation
Via Rossini 90/92
20033 Desio (Milan), Italy
Telephone: 39 0362 6121
Telefax: 39 0362 303396

Latin America

Flowserve Corporation
Boulevard del Cafetal
Edificio Ninina, Local 7
El Cafetal - Caracas
Venezuela 1061
Telephone: 58 212 985 3092
Telefax: 58 212 985 1007

Asia Pacific

Flowserve Pte. Ltd.
200 Pandan Loop #06-03/04
Pantech 21
Singapore 128388
Telephone: 65 6775 3003
Telefax: 65 6779 4607