



# ***Australia Wetherill Park Quick Response Center***

Maintenance and Repair • On-Site Services  
Parts and Components • Pump Retrofits and Upgrades



**FLOWSERVE**

Flow Solutions Group  
Wetherill Park QRC

***Experience In Motion***



## **Repair, Service and Technical Support for Australia and New Zealand**

*The Flowserve Australia Wetherill Park Quick Response Center (QRC) focuses on providing customers with uncompromising service and support.*

*The Australia Wetherill Park QRC is staffed by highly skilled engineers and technicians who are available around the clock, seven days a week to respond to customer queries, troubleshoot problems and provide reliable solutions.*

### **Strength of Experience, Commitment to Excellence**

The Australia Wetherill Park QRC serves customers from industries requiring superior equipment performance and service life, such as:

- Oil and gas production
- Hydrocarbon processing
- Chemical processing
- Water resources
- Power generation
- Mining and mineral processing
- Pulp and paper
- General industry
- Steel industry

### **Premier, Value-Added Service**

With unequaled pump and seal knowledge, design expertise and manufacturing capabilities, the Australia Wetherill Park QRC specializes in value-added repair services. QRC engineers and technicians service most types of equipment, including pumps, motors, compressors, agitators, valves and seals. The dynamic range of services offered by the Australia Wetherill Park QRC includes:

- Maintenance, repair and inspection service
- Pump upgrades, re-rates and retrofits
- Overhaul, outage and mechanical service
- Installation and commissioning service
- On-site repair and diagnostic services
- Contract maintenance
- Parts and components supply
- Field supervision
- Service maintenance contract





## Maintenance and Repair Services

### A Dynamic Range of Capabilities

The Australia Wetherill Park QRC facility features shop and office space to support repair, engineering, sales and customer service functions. In-shop operations can handle a full range of pumps from small, single-stage overhung units to large multistage, between bearing pumps.

The Australia Wetherill Park QRC facility offers extensive services, including:

- Machining capabilities:
  - Manual lathes
  - Manual milling machines
  - Horizontal and vertical boring mills
  - Radial, heavy duty press and industrial press drills
  - Shaft grinders
  - Welding
  - Painting
  - Sand blasting
- Testing:
  - Mag particle testing
  - API and SLC seal static pressure testing
  - Dynamic slurry seal test
  - Dynamic seal tester





## ***On-Site Services***

### ***Installation and Commissioning Service***

With limited staffing, customers often do not have the resources to supervise ongoing, equipment-related activities. As a result, field service experts from the Australia Wetherill Park QRC are available to support customer on-site requirements, including:

- Equipment installation
- Start-up and commissioning
- Equipment foundation inspection
- Pipe and pump bolt-up, alignment and inspection
- Equipment removal and handling
- Equipment transportation
- Maintenance activities



### ***Overhaul, Outage and Mechanical Services***

The Australia Wetherill Park QRC has extensive experience and resources to provide integrated outage and mechanical services. Field service teams offer rapid mechanical assistance, including maintenance, upgrade and inspection services during times of high demand.



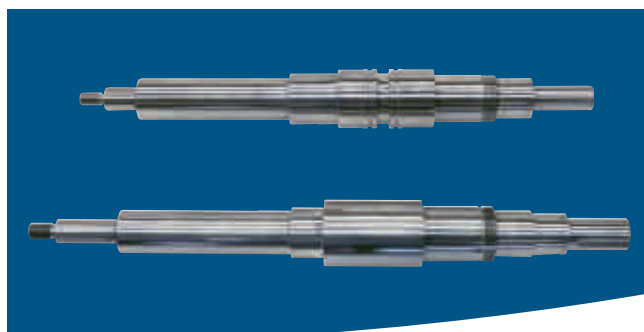

## Parts and Components

Quality parts in compliance with OEM specifications for the entire range of Flowserve product brands are readily available through the Australia Wetherill Park QRC. As all parts conform to original design and materials specifications, customers are ensured reliable operation and the lowest equipment ownership costs.

The Australia Wetherill Park QRC can also re-engineer and produce non-Flowserve components for equipment that is obsolete or when the original equipment manufacturer cannot be located.

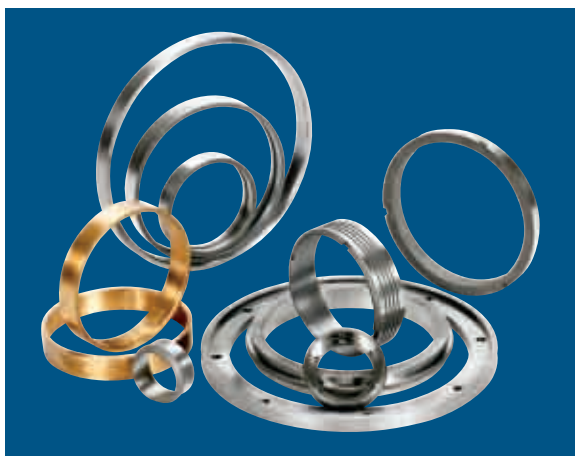

## The Flowserve Advantage

Flowserve manufactured parts offer significant benefits to customers. As an OEM, Flowserve understands the critical elements involved in designing and producing high quality parts. Whether cast or machined, Flowserve manufactured parts and components result in lower total operating costs and increased personnel safety.

- Flowserve casting quality is superior. Surface finishes, tolerances and material compositions are maintained within defined specifications.
- Flowserve parts incorporate the latest design changes which improve operating efficiency and extend equipment life.
- Customers benefit from ongoing research to develop new materials, overlay techniques and mechanically improved components.





## Upgrades, Re-rates and Retrofits

Unreliable and leaking pumps can be refurbished to “as-new” condition via a myriad of mechanical upgrade and retrofit options. Expert engineers from the Australia Wetherill Park QRC facility have the experience to analyze and diagnose the root causes of mechanical pump failure and recommend solutions that improve reliability, reduce emissions and increase plant uptime.

### Mechanical Upgrades and Retrofits

- ISO 13709/API 610 10<sup>th</sup> Edition upgrades, including the RVX and RHWX upgrades for horizontal and vertical overhung pumps, bring out-of-date process pumps to current API standards. This avoids costly new equipment investments.
- Other available mechanical upgrades include:
  - Increased rotor stiffness (Superstraight™ shaft material)
  - Bearing housing and bearings
  - Mechanical seal upgrade to API 682
  - Seal chamber
  - Coupling
  - Wear ring

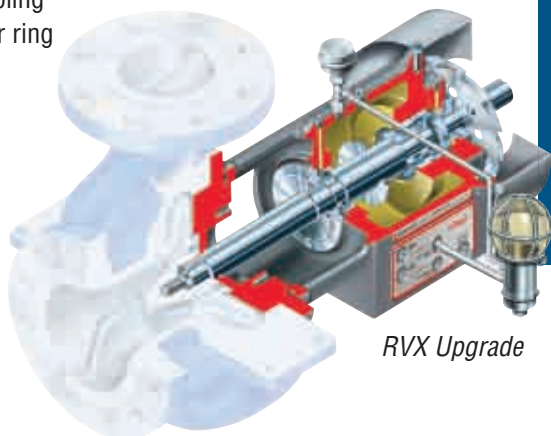

### Hydraulic Upgrades and Retrofits

Hydraulic re-rates can be provided to cover changes in flow or TDH, or increase efficiency for power savings.

- Optimization of lip and shroud clearances (A/B/C gap)
- Impeller modifications
- High-efficiency rotors
- Low flow modifications
- Re-bowling
- De-staging or upstaging
- Optimized hydraulics to reduce erosion/abrasion

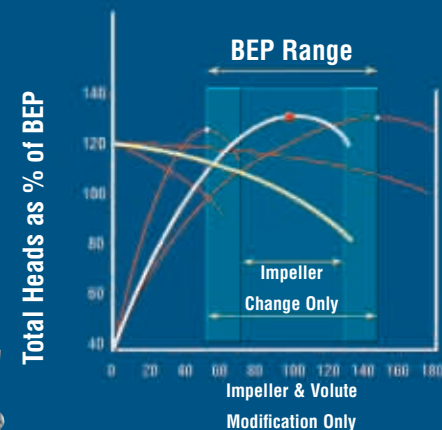

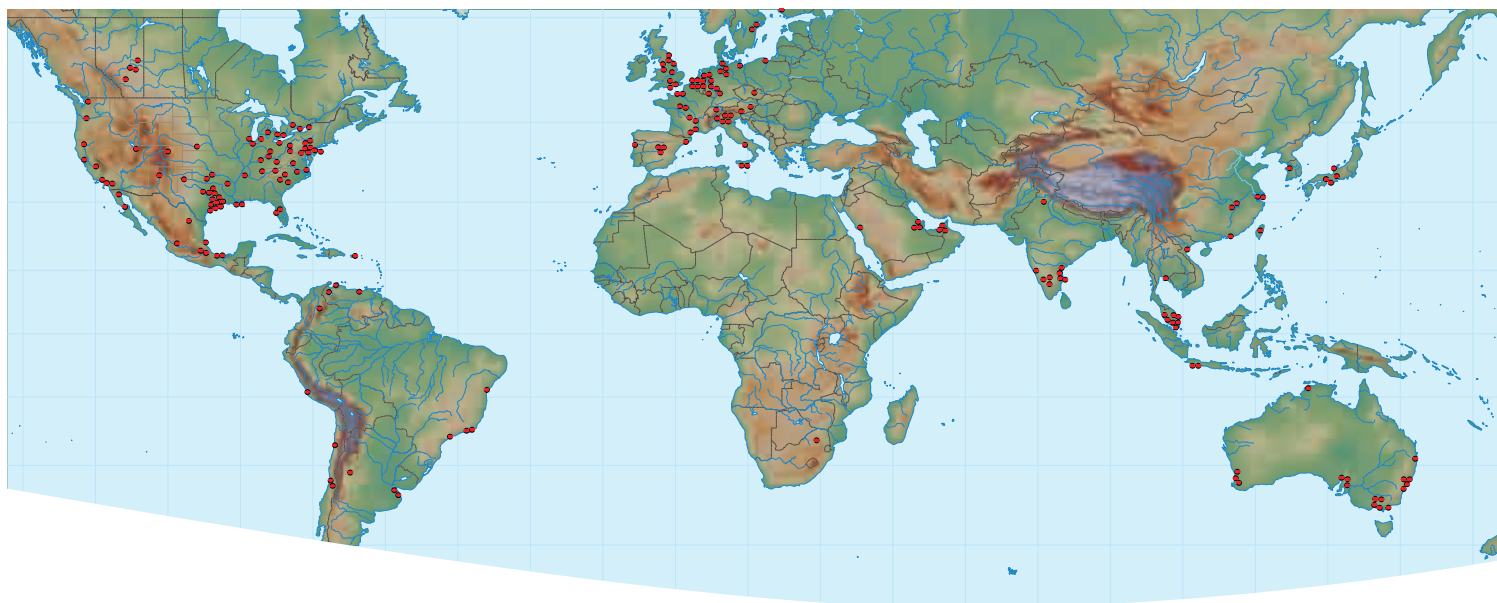

## ***Pump and Seal Supplier to the World***

With an installed base of more than one million pumps and seals, Flowserve has sales offices, service centers and manufacturing facilities throughout the world. As a result of its extensive global footprint, Flowserve is ideally positioned to deliver best-in-class solutions to successfully address the world's most challenging projects.

### ***Australia and New Zealand Quick Response Centers***





FPD-1498 (E/A4) October 2011. © Flowserve Corporation

**To find your local Flowserve representative:**

For more information about Flowserve Corporation, visit [www.flowserve.com](http://www.flowserve.com) or call +1 937 890 5839.

**Australia**

Wetherill Park QRC (Pump)  
Unit 1, 171-175 Netwon Rd,  
Wetherill Park, NSW., 2164  
Australia  
Tel: (61) 2 9623 3900  
Fax: (61) 2 9673 1870

Mulgrave QRC (Pump)  
Unit 5, 3 Faigh Street, Mulgrave,  
VIC., 3170, Australia  
Tel: (61) 3 9574 3100  
Fax: (61)3 9574 3161

Welshpool QRC (Pump)  
Unit 1, 29 McDowell St.  
Welshpool, 6106, Perth, Australia  
Tel: (61) 8 9451 6600  
Fax: (61) 8 9458 2051

Marayong QRC (Seal)  
8 Binney Road, Marayong, NSW.,  
2148, Australia  
Tel: (61) 2 8822 7100  
Fax: (61) 2 9679 7511

Henderson QRC (Seal)  
55 Quill Way, Henderson, WA.,  
6166, Australia  
Tel: (61) 8 9494 9200  
Fax: (61) 8 9494 9201

Darwin QRC (Seal)  
31 McCourt Road, Yarrowona, NT.,  
0830, Darwin, Australia  
Tel: (61) 8 8931 5252  
Fax: (61) 8 8931 5255

Townsville QRC (Pump&Seal)  
Unit 3, 5-7 Turnbull St. Garbutt,  
Townsville, 4814, Australia  
Tel: (61) 7 4728 1211  
Fax: (61) 7 4728 1270

Mulgrave QRC (Seal)  
Unit 17/35 Dunlop Road,  
Mulgrave, VIC., 3170, Australia  
Tel: (61) 3 9535 5900  
Fax: (61) 3 9535 5901

**New Zealand**

Christchurch QRC (Pump)  
18 Hammersmith Drive, Wigram,  
Christchurch, 8042, New Zealand  
Tel: (64) 3 3434 511  
Fax: (64) 3 3434 514

Auckland QRC (Seal)  
Suite A, Unit K, 701 Great South  
Rd., Penrose, Auckland, 1601  
New Zealand  
Tel: (64) 9 2571 270  
Fax: (64) 9 2571 277