



# *USER INSTRUCTIONS*

## **ARG Series Standard Actuator**

*FCD ACENIM0122-00 12/12*

*Installation  
Operation  
Maintenance*

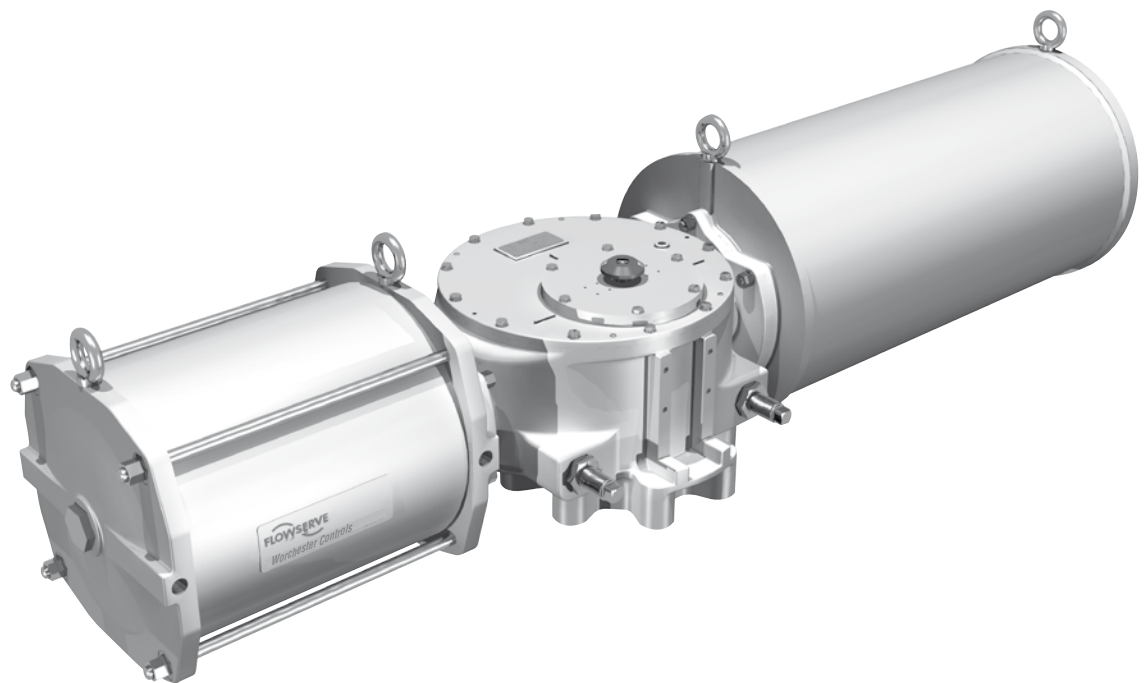

*Experience In Motion*

## INDEX

- 1 Using Flowserve Valves, Actuators and Accessories Correctly
- 2 Installation
- 3 Travel Stop Adjustments
- 4 Maintenance Instructions
- 5 Field Conversion from Fail CW to Fail CCW
- 6 Torque Shaft
- 7 Long Term Storage

### 1 Using Flowserve Valves, Actuators and Accessories Correctly

#### 1.1 General usage

The following instructions are designed to assist in unpacking, installing and performing maintenance as required on FLOWSERVE products. Product users and maintenance personnel should thoroughly review this bulletin prior to installing, operating or performing any maintenance.

In most cases FLOWSERVE valves, actuators and accessories are designed for specific applications with regard to medium, pressure and temperature. For this reason they should not be used in other applications without first contacting the manufacturer.

#### 1.2 Terms concerning safety

The safety terms **DANGER**, **WARNING**, **CAUTION** and **NOTE** are used in these instructions to highlight particular dangers and/or to provide additional information on aspects that may not be readily apparent.



**DANGER:** indicates that death, severe personal injury and/or substantial property damage will occur if proper precautions are not taken.



**WARNING:** indicates that death, severe personal injury and/or substantial property damage can occur if proper precautions are not taken.



**CAUTION:** indicates that minor personal injury and/or property damage can occur if proper precautions are not taken.



**NOTE:** indicates and provides additional technical information, which may not be very obvious even to qualified personnel.

Compliance with other, not particularly emphasised notes, with regard to transport, assembly, operation and maintenance and with regard to technical documentation (e.g. in the operating instruction, product documentation or on the product itself) is essential, in order to avoid faults, which in themselves might directly or indirectly cause severe personal injury or property damage.

#### 1.3 Protective clothing

FLOWSERVE products are often used in problematic applications (e.g. extremely high pressures, dangerous, toxic or corrosive mediums). In particular valves with bellows seals point to such applications. When performing service, inspection or repair operations always ensure, that the valve and actuator are depressurised and that the valve has been cleaned and is free from harmful substances. In such cases pay particular attention to personal protection (protective clothing, gloves, glasses etc.).

#### 1.4 Qualified personnel

Qualified personnel are people who, on account of their training, experience and instruction and their knowledge of relevant standards, specifications, accident prevention regulations and operating conditions, have been authorised by those responsible for the safety of the plant to perform the necessary work and who can recognise and avoid possible dangers.

#### 1.5 Installation



**DANGER:** Before installation check the order-no., serial-no. and/or the tag-no. to ensure that the valve/actuator is correct for the intended application.

Do not insulate extensions that are provided for hot or cold services.

Pipelines must be correctly aligned to ensure that the valve is not fitted under tension.

Fire protection must be provided by the user.

#### 1.6 Spare parts

Use only FLOWSERVE original spare parts. FLOWSERVE cannot accept responsibility for any damages that occur from using spare parts or fastening materials from other manufactures. If FLOWSERVE products (especially sealing materials) have been on store for longer periods check these for corrosion or deterioration before using these products. Fire protection for FLOWSERVE products must be provided by the end user.

### 1.7 Service / repair

To avoid possible injury to personnel or damage to products, safety terms must be strictly adhered to. Modifying this product, substituting nonfactory parts, or using maintenance procedures other than outlined in this instruction could drastically affect performance and be hazardous to personnel and equipment, and may void existing warranties. Between actuator and valve there are moving parts. To avoid injury FLOWSERVE provides pinch-point-protection in the form of cover plates, especially where side-mounted positioners are fitted. If these plates are removed for inspection, service or repair special attention is required. After completing work the cover plates must be refitted.

Apart from the operating instructions and the obligatory accident prevention directives valid in the country of use, all recognised regulations for safety and good engineering practices must be followed.



***WARNING: Before products are returned to FLOWSERVE for repair or service FLOWSERVE must be provided with a certificate which confirms that the product has been decontaminated and is clean. FLOWSERVE will not accept deliveries if a certificate has not been provided (a form can be obtained from FLOWSERVE).***

### 1.8 Storage

In most cases FLOWSERVE products are manufactured from stainless steel. Products not manufactured from stainless steel are provided with an epoxy resin coating. This means that FLOWSERVE products are well protected from corrosion. Nevertheless FLOWSERVE products must be stored adequately in a clean, dry environment. Plastic caps are fitted to protect the flange faces to prevent the ingress of foreign materials. These caps should not be removed until the valve is actually mounted into the system.

### 1.9 Valve and actuator variations

These instructions cannot claim to cover all details of all possible product variations, nor can they provide information for every possible example of installation, operation or maintenance. This means that the instructions normally include only the directions to be followed by qualified personal where the product is being used for is defined purpose. If there are any uncertainties in this respect particularly in the event of missing product-related information, clarification must be obtained via the appropriate FLOWSERVE sales office.

### 1.10 Unpacking

Each delivery includes a packing slip. When unpacking, check all delivered valves and accessories using this packing slip.

Report transport damage to the carrier immediately.

In case of discrepancies, contact your nearest FLOWSERVE location.

**Introduction**

The ARG Series is a fully modular design, scotch-yoke actuator; with torque range from 2000Nm to 250,000Nm (2,800 in-Lbs to 2.2 M in-Lbs) in eight models, ARG1 through ARG8, with maximum actuator torque and mounting base in compliance with ISO 5211.

The ARG series Spring Return Actuators, in contrast with R-series, use Pull-to-Compress the spring design.

**2 Installation**

2.1 All actuators are factory lubricated for life, but still should be protected from the elements and stored indoors until ready for use. The ports of the actuator are plugged as supplied from the factory. If actuators are stored for a long period of time prior to installation, follow the Long Term Storage instructions.

2.2 Prior to assembly, manually open and close valve (if possible), to ensure freeness of operation. Be sure, valve and Wochester Controls actuator rotate in the same direction and are in the same position (i.e., valve closed, actuator closed).

2.3 Check the mounting surfaces, the stem adaptor and the bracket to assure proper fit. Secure the valve in the closed position with the stem vertical. Bolt the bracket to the valve and place the stem adaptor on the valve stem. Position the actuator over the valve and lower, to engage the stem adaptor to the actuator's bore. Continue to lower until the actuator seats on the bracket mounting surface. In order to align the bolt holes, it may be necessary to loosen the valve-to-bracket bolting to allow more play in the bracket. The mounting bolts should easily fit into the bolt holes without any binding. If needed, turn or stroke the actuator a few degrees and/or adjust the actuator travel stops. Bolt the actuator to the bracket.

2.4 Adjust the travel stop bolts of the actuator for the proper open and closed valve positions, per valve manufacturer's recommendations. Pneumatically stroke the actua-

tor several times to assure proper operation. The stem adaptor should not bind during operation. If the actuator is equipped with an UltraSwitch or other accessories, adjust them at this time.

2.5 To prolong actuator life use only clean, dry plant air. Lubricated air is not required, however it is recommended particularly for high cycle applications. Do not use lubricated air with positioners.



**CAUTION! Lifting bolts holes on the actuator are for lifting the actuator modules only with eye bolts, not a complete valve and actuator assembly.**

**3 Travel Stop Adjustments**

All actuated valves require accurate travel-stop adjustments at both ends of the stroke to obtain optimum performance and valve seat life. The accumulation of tolerances in the adaption of actuators to valves is such that there must be a range of adjustments for both ends of the stroke to achieve optimum performance.

The ARG actuators have travel stop adjustments in both the clockwise and counter-clockwise directions. The +/- 3 degree adjustment feature provides shaft rotation from 84 to 96 degrees.

**4 Maintenance Instructions**

**4.1 Disassembly Instructions**

4.1.1 Disconnect all air and electrical supplies from actuator.

4.1.2 Remove all accessories from actuator and dismount actuator from valve.

4.1.3 Drawing References: Drg # 263188, Drg # 263189

**4.2 Spring Module (see Fig.: 1)**



**CAUTION! Personal Injury may result if Step 2 is attempted before Step 1 is completed.**

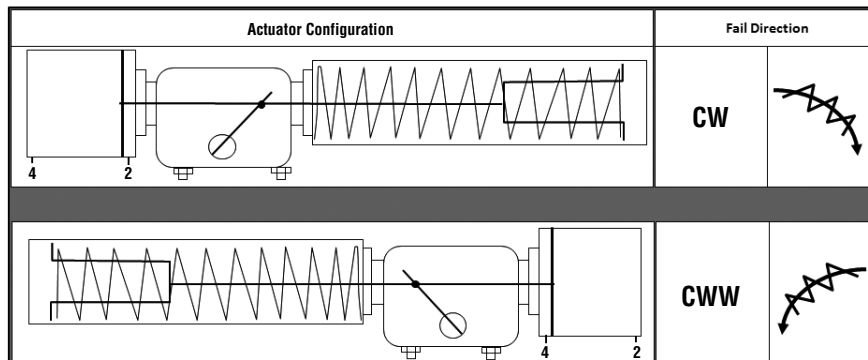

**Fig.: 1 Spring Module**

4.2.1 Apply air pressure to port 2 on FCW (port 4 on FCCW) actuator, raising pressure slowly, enough to release spring pressure from the Stop Bolt (17). Back off fully both Stop Bolts on the Torque Module and release air pressure. This will relieve the spring preload.

4.2.2 The Spring Module is welded into an integral component and cannot be disassembled. To remove from actuator, remove Spring Module end cover (60) and using an extended socket spanner /tube spanner, unscrew and disconnect the Pull Rod (54) from the Torque Module.



**CAUTION! Take extra care not to drop the socket/small tools inside the spring can. Small objects dropped inside may fall through the spring guide and get stuck in the spring coils.**



**NOTE: A retainer ring on the threaded side of the Pull Rod stops it from being removed completely from the Spring Module.**

4.2.3 Sling the Spring Module using lifting bolts on the Module and remove the Adapter Nuts (19) and Lock washers (20).Spring Module can now be removed from the Torque Module.

4.2.4 Before reassembling Spring Module to body, make sure stud threads are clean of any dirt, shavings, or other debris. Clean threads with rag and solvent if required, and lubricate threads with an anti-seize compound.



**NOTE: Support the Spring Module during removal so as not to damage the Pull Rod and the studs' threads.**

### 4.3 Pressure Module

4.3.1 Pressurize rod end of cylinder, enough to stroke to end. Vent out the air from the cylinder.

4.3.2 Remove end cover plate/plug from pressure module and unscrew the piston rod with a socket/tube spanner.

4.3.3 Sling the pressure module from the eye bolts, remove the Adaptor Stud Nuts (19) and Lock washers (20) and take the Pressure module off the Torque module.

4.3.4 Remove the Tie Rod Nuts (37), the End Plate (33) and Tie Rods (36).

4.3.5 Slide the Cylinder (34) over and off the Piston (38), being careful not to scratch or dent the honed and chrome plated surface of the cylinder.

4.3.6 Slide out the Piston- Piston Rod assembly off the Adapter Plate (32).

4.3.7 Remove the Retainer Ring (40) and take the Split Collar (39) off the Piston Rod (35).Pull the Piston Rod off the Piston.

### 4.4 Torque Module (Body Group)



**NOTE: Spring Module and Pressure Module must be removed before disassembling the Torque Module**

4.4.1 Remove the Indicator (29), if fitted.

4.4.2 Remove Top Cover Bolts (65) and the cover, O-ring and the Namur Shaft Assembly (15).

4.4.3 Remove Body Cover Bolts, Lock Washers (26) and Thread Plugs (31).

4.4.4 Using the removed Body Cover Bolts, jack open the cover by threading in the bolts in the two tapped holes until cover is separated enough to pry apart. Take care to jack the bolts evenly, as the cover is positioned by four dowel pins, and cross loading may cause bending/ breakage of pins on small actuator sizes.

4.4.5 Gently tap with PU/Plastic hammer and pull off the Guide Bar (2) from the body.

4.4.6 Lift Yoke Sub Assembly out of body bore.

4.4.7 Remove Delrin Plate (7) retaining screws. Pull out the Yoke Pin (9), and Slider Block (10).

4.4.8 Slide out the Guide Block (11) out of the Yoke and remove the bottom Slider Block.

4.4.9 Remove Yoke Seals (5) and Yoke Bushing (4) if worn out/damaged.

### 4.5 Reassembly Instructions

4.5.1 Inspect all parts for wear and replace any worn parts as needed. Normally, all O-rings and seals should be replaced when reassembling an actuator. Use seal lubricant, Dow Corning 55 for all lubrication in the pressure group. Ensure the replacement seals are suitable for the service temperature.

4.5.2 The Metal backed bronze-ptfe bearings may be inspected and assessed for replacement, referring to guide (see Fig.: 2) on the useful residual life To replace the bearings, the unit or the subassembly

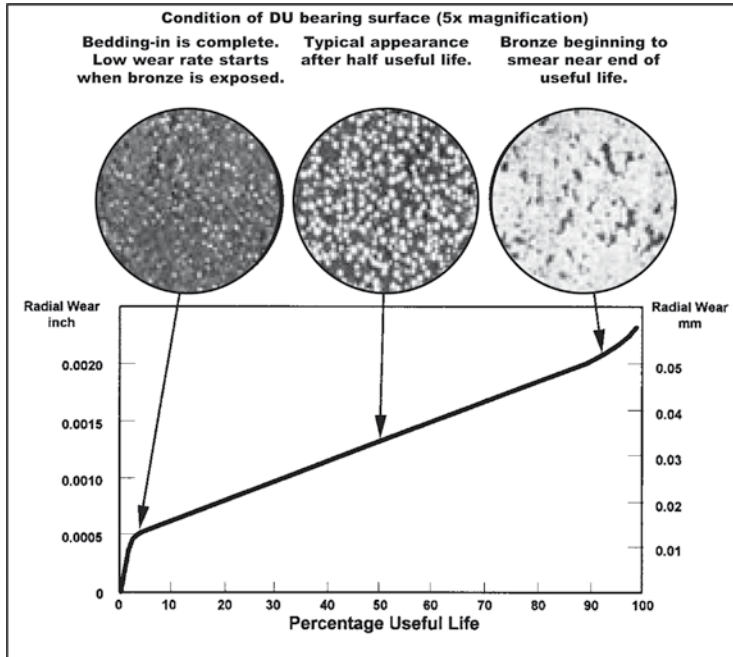

**Fig.: 2 Residual Life Guide**

needs to be brought in to workshop, with suitable facilities to carefully remove the bearing without damaging the housing and to press new bearing with proper pressing tools per manufacturer's instructions and a press.  
Do not attempt to pry out any of the bearings in the actuator with sharp tools, or hammer in a replacement bearing.

- 4.5.3 Clean thoroughly and grease all Torque Module components with NLGI grade 2 multi-purpose grease. Use Shell Alvania EP2 for Standard Actuators. For low temperature units, use Dow 55 grease or equivalent.
- 4.5.4 Reverse the disassembly procedures to reassemble. Apply recommended torque, refer torque chart, on the Tie Rod Locknuts, the Mounting Flange Nuts, the Body Cover & Top Plate bolts, the Piston Rod / Pull Rod (see tables on page 7). The Tie Rod and Mounting Flange Stud threads should be lubricated with Loctite Antiseize, 77164 or equivalent. The Pull /Piston Rod threads and cover bolts to be tightened with thread lock compound, Loctite 243 or equivalent.
- 4.5.5 Refer to parts and materials drawings for all required spare parts (see pages 9 + 10). Test the actuator for smooth operation and air leakage at service pressure before reinstalling into service.

## 5 Field Conversion from Fail CW to Fail CCW (For Spring Return Actuators)

The ARG spring return actuator can be converted from fail CW to fail CCW easily, without having to remove the Torque Module, mounting bracket, stem adaptor and the shaft driven accessories, mounted on the centre body . Simply switch the positions of the Pressure and Spring Modules.  
Actuator Designation needs to be suitably changed on the name plate.  
Follow steps below, if operating the valve is permitted:

- 5.1 Apply enough air pressure to the actuator to relieve spring load on the stopper bolt.
- 5.2 Back off both the stopper bolts on the Torque Module and depressurize the actuator.
- 5.3 Remove Spring Module end cover, unscrew and disconnect the Spring Pull Rod.
- 5.4 Pressurize rod end of Pressure Module, to end of stroke. Depressurize and remove the end cover/plug on the Pressure Module. Use a tube/socket spanner, loosen piston rod by one turn, fit back end cover/plug and pressurize cap end, enough to stroke to end. Depressurize, remove end cover/plug and fully unscrew and disconnect the piston rod from the Torque Module.
- 5.5 Remove the Pressure and Spring Modules off the Torque Module by removing the mounting flange stud nuts.

### Bolt Torques

Fastner	Model	ARG1	ARG2	ARG3	ARG4	ARG5	ARG6	ARG7	ARG8	
Mounting Flange Nut	Thread Size	M8	M10	M12	M12	M16	M16			
	Tightning torque	ft Lb	10-12	18-22	30-35	30-35	80-90	80-90	140-160	280-320
		kgm	1.4-1.7	2.5-3.0	4.2-4.8	4.2-4.8	11.0-12.5	11.0-12.5	19-22	38-44
Body Cover Bolts	Thread Size	M6	M6	M8	M8	M10	M10			
	Tightning torque	ft Lb	3-5	3-5	10-14	10-14	18-22	18-22	26-30	26-30
		kgm	0.5-0.7	0.5-0.7	1.4-2.0	1.4-2.0	2.5-3.0	2.5-3.0	3.5-4.0	3.5-4.0
Top Plate Bolts	Thread Size	M6	M6	M8	M8	M10	M10			
	Tightning torque	ft Lb	3-5	3-5	10-14	10-14	18-22	18-22	22-26	22-26
		kgm	0.5-0.7	0.5-0.7	1.4-2.0	1.4-2.0	2.5-3.0	2.5-3.0	3.0-3.5	3.0-3.5
Stopper Bolt Locknuts	Thread Size	M16	M20	M20	M30	M36	M48	M56	M64	
	Tightning torque	ft Lb	75-85	90-100	90-100	100-110	120-130	140-150	175-200	200-240
		kgm	10-12	12-14	12-14	14-15	16-18	19-21	25-28	28-33
Piston Rod/Pull Rod	Hex Size, A/F	18	18	24	30	36	46	65	85	
	Tightning torque	ft Lb	30-35	35-45	50-60	60-75	75-85	100-140	175-200	200-240
		kgm	4-5	4-5	7-8	8-10	10-12	13-19	24-28	28-33

### Tie Rod Nut Torque

Cylinder Size (in.)	5	6	7	8	9	10	12	14	16	18	20	22	24	28	32	32T	36	36T	40
Tie Rod Nut Size	M10	M10	M10	M10	M12	M12	M16	M16	M20	M20	M24	M24	M30	M30	M30	M36	M30	M36	M30
Tightening Torque (ft Lb)	8	11	14	19	28	34	64	88	143	181	268	325	485	330	431	1028	564	876	673

- 5.6 Switch the positions of the two modules, connect the Pressure Module first and ensure the ports are on the stopper bolts side of actuator. Thread in and torque the piston rod to recommended value, fit back end cover plate/plug. Pressurize cap end to stroke the actuator to end.
- 5.7 Reinstall Spring Module, torque the pull rod to recommended value, fit end cover back. Pressurize rod end of cylinder and adjust the stopper bolts.
- 5.8 Check actuator for proper operation, at the rated working pressure.

**!** *NOTE: If operation of valve is not permitted, during changing of the Fail Safe direction, then the actuator needs to be taken off the valve and reconfigured, as explained above.*



### Actuator Designation

How to Order															
Series	Body Size	Cylinder Size				Action	Spring Module	Torque Pattern (Yoke)	Sealing/Temp	Manual Override	Material/ Coatings	Options			
ARG	1	05	06	07	08	09	10	12	DA- Double Acting Single Cylinder	0	S- Symmetrical	N- Nitrile, -20° F to 180° F	O- None	GE- Grey Epoxy (std)	00- None
	2	08	09	10	12	14	16	DD- Double Acting Dual Cylinder	1	C- Canted		G- Sandwich Declutch Gbox	PO- Primer Only	TC- Ext. Stopper -CW	
	3	10	12	14	16	18	20	SR- Spring Return Fail CW	2		H- High Temp (Viton), 0° F to 300° F	J- Jackscrew	WE- White Epoxy	TO- Ext. Stopper -CCW	
	4	14	16	18	20	22	24	SO- Spring Return Fail CCW	3		L- Low Temp, (material) -55° F to 180° F	D- Bevel Gear Jackscrew	SP- Specials	TB- Ext. Stopper -Both Dir	
	5	16	18	20	22	24	28		4			H- Hydraulic		S xxx- Specials code	
	6	18	20	22	24	28	32	36		5					
	7	24	28	32	36	40		6							
	8	28	32	36	40		7								
							8								
Model Code Example:															
ARG	5	22				SR	6	C	N	D	GE	TC			

Body Size	Max. Cylinder Size		
	DA	DD	SR/SO
1	9	8	12
2	12	10	16
3	16	14	20
4	20	16	24
5	22	20	28
6	28	24	36
7	36	32	40
8	40	40	40

### Module Weights (approx.)

Model	Torque Module	Module Weights, Lbs (kgs)																							
		Pressure Module																Spring Module							
		5	6	7	8	9	10	12	14	16	18	20	22	24	28	32	36	40	1	2	3	4	5	6	7
ARG1	68 (31)	31 (14)	35 (16)	47 (22)	53 (24)	66 (30)	94 (43)	139 (63)	-	-	-	-	-	-	-	-	-	88 (40)	97 (44)	101 (46)	103 (47)	106 (48)	114 (52)	119 (54)	119 (54)
ARG2	99 (45)	-	-	-	56 (25)	69 (32)	99 (45)	143 (65)	209 (95)	320 (145)	-	-	-	-	-	-	-	128 (58)	145 (66)	154 (70)	158 (72)	158 (72)	172 (78)	180 (82)	186 (85)
ARG3	143 (65)	-	-	-	-	100 (45)	142 (64)	200 (91)	318 (145)	406 (185)	561 (255)	-	-	-	-	-	-	226 (103)	260 (118)	267 (121)	269 (122)	276 (125)	330 (150)	321 (146)	-
ARG4	295 (134)	-	-	-	-	-	-	217 (99)	339 (154)	427 (194)	586 (266)	741 (337)	942 (428)	-	-	-	-	402 (183)	442 (201)	462 (210)	477 (217)	510 (232)	545 (248)	565 (257)	581 (254)
ARG5	510 (231)	-	-	-	-	-	-	-	356 (162)	455 (207)	610 (277)	853 (388)	994 (452)	1634 (743)	-	-	-	639 (290)	737 (335)	770 (350)	783 (356)	901 (410)	955 (434)	-	-
ARG6	933 (423)	-	-	-	-	-	-	-	-	493 (224)	616 (280)	861 (391)	1051 (478)	1732 (787)	2321 (1055)	3044 (1384)	-	1283 (583)	1738 (790)	1671 (760)	1730 (787)	2061 (937)	1995 (907)	-	-
ARG7	1881 (853)	-	-	-	-	-	-	-	-	-	-	-	-	1824 (829)	2411 (1096)	3156 (1435)	3913 (1779)	2283 (1038)	2946 (1339)	3043 (1383)	3177 (1444)	3630 (1650)	3709 (1686)	-	-
ARG8	3718 (1686)	-	-	-	-	-	-	-	-	-	-	-	-	2165 (984)	2819 (1282)	3372 (1533)	4159 (1891)	4627 (2103)	5800 (2637)	6113 (2779)	6227 (2830)	7111 (3232)	7423 (3374)	-	-



Drawing # 263188

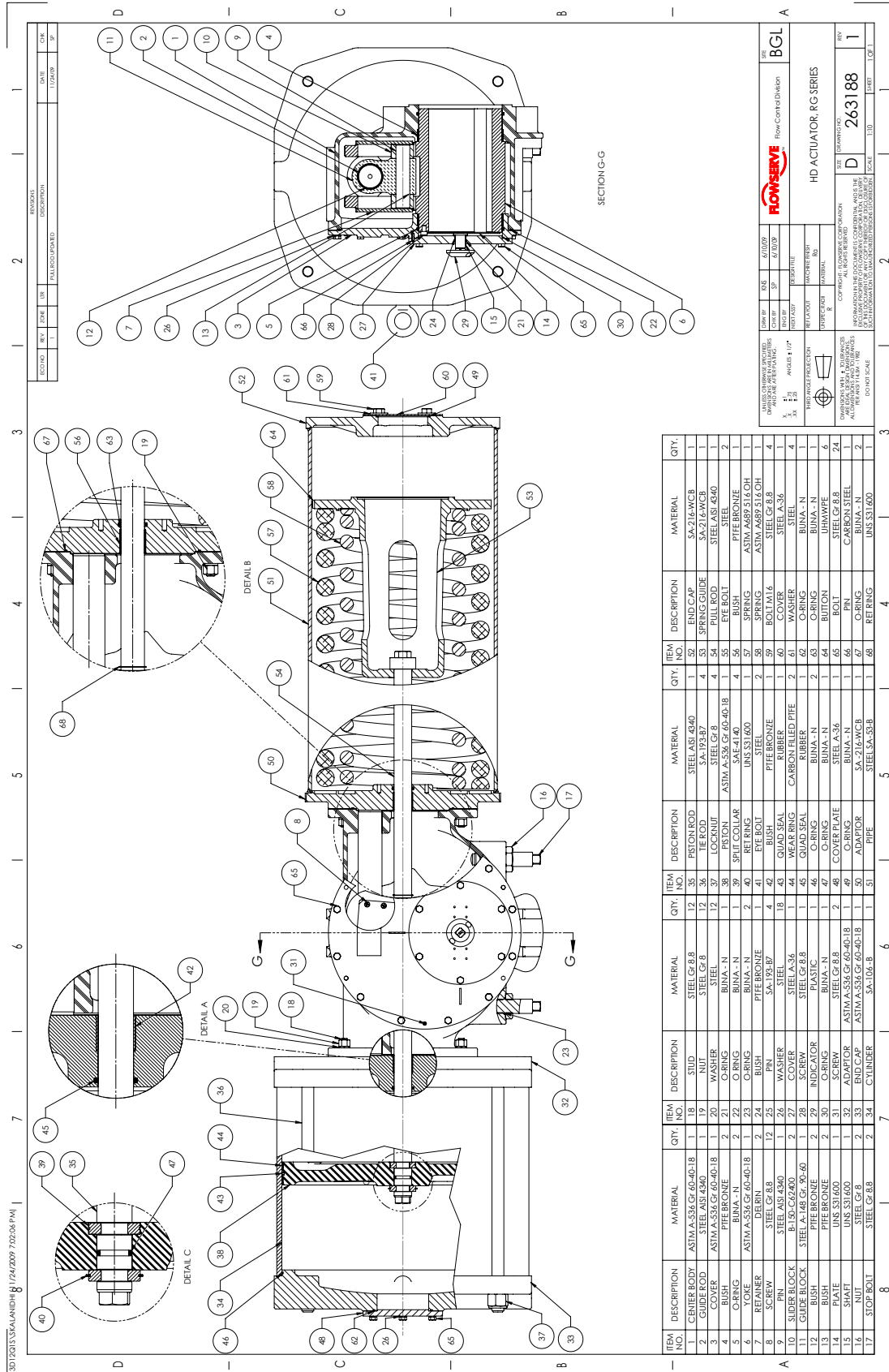

ITEM NO.	DESCRIPTION	MATERIAL	QTY.	ITEM NO.	DESCRIPTION	MATERIAL	QTY.	ITEM NO.	DESCRIPTION	MATERIAL	QTY.
1	CENTER BODY	ASTM A 536 Gr 60-40-18	1	12	PISTON ROD	STEEL AS1 6840	1	55	FLUID CAP	SA-271 LAMBR	1
2	COVER	ASTM A 536 Gr 60-40-18	1	13	LOCKWASHER	STEEL AS1 6840	4	56	SPRING GUIDE	SA-271 LAMBR	1
3	COVER	ASTM A 536 Gr 60-40-18	1	14	LOCKWASHER	STEEL AS1 6840	4	57	PULL ROD	STEEL AS1 6840	1
4	BUSH	PISTE BRONZE	2	15	PISTON	ASTM A 536 Gr 60-40-18	2	58	EYE BOLT	STEEL	2
5	O-RING	BUNA - N	2	16	SPLIT COLLAR	SAE-4140	4	59	SPRING	PITE BRONZE	4
6	YOKE	ASTM A 536 Gr 60-40-18	1	17	RETING	UNS S31 600	1	60	SPRING	ASTM A 569 516 OH	1
7	RETAINER	DELRI	1	18	EYE BOLT	STEEL	2	61	WASHER	STEEL	4
8	SCREW	ASTM A 536 Gr 60-40-18	12	19	QUARTER	PISTE BRONZE	4	62	COVER	STEEL	4
9	SCREW	ASTM A 536 Gr 60-40-18	12	20	QUARTER	PISTE BRONZE	4	63	WASHER	STEEL	4
10	SLIDER BLOCK	ASTM A 536 Gr 60-40-18	2	21	QUARTER	PISTE BRONZE	4	64	O-RING	BUNA - N	1
11	GUIDE BLOCK	ASTM A 536 Gr 60-40-18	2	22	COVER	STEEL A 36	2	65	O-RING	BUNA - N	1
12	BUSH	PISTE BRONZE	2	23	SCREW	STEEL G 8 8	1	66	O-RING	BUNA - N	1
13	BUSH	PISTE BRONZE	2	24	INDICATOR	PISTE	1	67	BUTTON	UHMWPE	6
14	PLATE	UNS S31 600	1	25	O-RING	BUNA - N	1	68	COVER PLATE	STEEL A 36	1
15	SCREW	ASTM A 536 Gr 60-40-18	1	26	O-RING	BUNA - N	2	69	ADAPTOR	ASTM A 536 Gr 60-40-18	2
16	SCREW	ASTM A 536 Gr 60-40-18	1	27	SCREW	ASTM A 536 Gr 60-40-18	1	70	PIPE	UNS S31 600	1
17	STOP BOLT	STEEL G 8 8	2	28	END CAP	ASTM A 536 Gr 60-40-18	2	71	PIPE	UNS S31 600	1
18	STOP BOLT	STEEL G 8 8	2	29	CYLINDER	ASTM A 536 Gr 60-40-18	1	72	PIPE	UNS S31 600	1



## 6 Torque Shaft

The output shaft is recommended to have two key engagements. Shaft material shall be alloy steel with minimum yield strength of 85,000psi. The recommended hardness of keys is 25-28HRc. Recommended engagement length of the keys is as below (see Fig.: 3).

Model	$L_k$ (mm)	$L_o$ (mm)
ARG1	165	180
ARG2	195	210
ARG3	200	215
ARG4	255	270
ARG5	300	315
ARG6	350	375
ARG7	500	515
ARG8	585	610

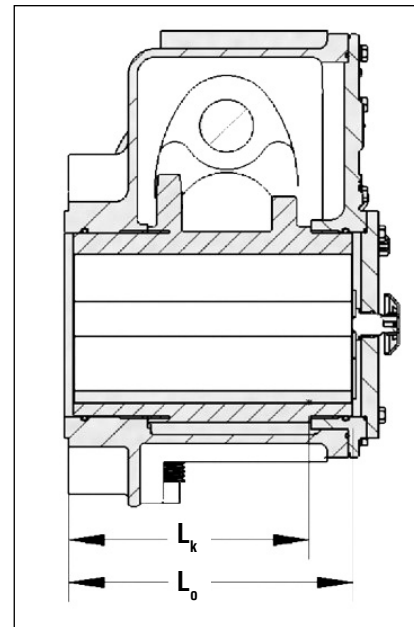

Fig.: 3 Key Length

## 7 Long Term Storage

It is recommended to take precautions and certain measures when storing the actuators for extended periods of time, more than 4 months to two years. Potential problems and recommended protections are as below:

Potential Problem	Protection
Water entry into pneumatic cylinder, degrades the cylinder, particularly in saline or corrosive environment. Temperature swings cause condensation inside cylinders	<ul style="list-style-type: none"> <li>• Store actuator in clean, dry and protected warehouse, or under ventilated dust cover.</li> <li>• Plug all ports after purging with dry instrument air or nitrogen.</li> <li>• Store vertical, to avoid seal set.</li> </ul>
Seal compression set	Cycle actuator 5-6 times with clean dry instrument air or nitrogen, every 3 months.
Degradation of seals in excessively corrosive or hot environments	<ul style="list-style-type: none"> <li>• Do not store in locations subjecting the actuator to temperatures in excess of seal rating. Std seals are Nitrile, max temp 180deg F.</li> <li>• Do not store in environments harmful to resilient seals.</li> </ul>
Physical damage to actuator or accessories.	Store actuator assembly on skid, off the floor, out of pathways.

Inspect the protections every 3 months and record inspection results.



Contact:



All data subject to change without notice

© ©12.2010 Flowserve Corporation. Flowserve and Kämmer are trademarks of Flowserve Corporation

Flowserve Corporation has established industry leadership in the design and manufacture of its products. When properly selected this Flowserve product is designed to perform its intended function safely during its useful life. However, the purchaser or user of Flowserve products should be aware that Flowserve products might be used in numerous applications under a wide variety of industrial service conditions. Although Flowserve can (and often does) provide general guidelines, it cannot provide specific data and warnings for all possible applications. The purchaser/user must therefore assume the ultimate responsibility for the proper sizing and selection, installation, operation, and maintenance of Flowserve products. The purchaser/user should read and understand the Installation Operation Maintenance (IOM) instructions included with the product, and train its employees and contractors in the safe use of Flowserve products in connection with the specific application.

While the information and specifications contained in this literature are believed to be accurate they are supplied for informative purposes only and should not be considered certified or as a guarantee of satisfactory results by reliance thereon. Nothing contained herein is to be construed as a warranty or guarantee, expressed or implied, regarding any matter with respect to this product. Because Flowserve is continually improving and upgrading its product design, the specifications, dimensions and information contained herein are subject to change without notice. Should any question arise concerning these provisions, the purchaser/user should contact Flowserve Corporation at any one of its worldwide operations or offices.

**Flowserve Flow Control (UK) Ltd.**  
Burrell Road  
Haywards Heath  
West Sussex United Kingdom RH16 1TL  
Phone: +44 1444 314400  
Fax: +44 1444 314401

**Flowserve Corporation  
Flow Control Division**  
1978 Foreman Drive  
Cookeville, Tennessee 38501 USA  
Phone: +931 432 4021  
Fax: +931 432 5518

**Flowserve Pte Ltd**  
No. 12 Tuas Avenue 20  
Singapore 638824  
Phone: +65 6879 8900  
Fax: +65 6862 4940

**Flowserve Flow Control Benelux BV**  
Rechtzaad 17  
4703 RC Roosendaal NB  
Netherlands  
Phone: +31 165 598 800  
Fax: +31 165 555 670

**Flowserve Australia Pty Ltd**  
Flow Control Division  
14 Dalmore Drive  
Scoresby, Victoria 3179  
Australia  
Phone: +61 3 9759 3300  
Fax: +61 3 9759 3301

**Flowserve do Brasil Ltda**  
Rua Tocantins, 128 - Bairro Nova Gerti  
São Caetano do Sul,  
São Paulo 09580-130 Brazil  
Phone: +5511 4231 6300  
Fax: +5511 4231 6329 - 423

**Unit 01020607 9F**  
China Fortune Tower  
No. 1568, Century Avenue, Pudong  
Shanghai China 200122  
Phone: +86 21 38654800  
Fax: +86 21 50811781

**Flowserve Corporation**  
No. 35, Baiyu Road  
Suzhou Industrial Park  
Suzhou 215021, Jiangsu Province, PRC  
Phone: +86-512-6288-1688  
Fax: +86-512-6288-8737

**Flowserve China**  
Hanwei Building  
No. 7 Guanghua Road  
Chao Yang District  
1000004 Beijing  
CHINA  
Phone: +86 (10) 6561 1900  
Fax: +86 (10) 6561 1899