

SLD

Synthetic Lubrication Device

The SLD seal support system from Flowserve dispenses lubrication to the atmospheric side of mechanical seals. It is ideal for seals subjected to periods of dry running or cavitation when product liquid (pumpage) does not provide adequate film between seal faces. The SLD is proven to greatly extend flushless seal life in harsh slurry conditions.



Features and Benefits

- Standard configuration used in conjunction with different seal models; stand-alone system does not require air, electricity, or external water.
- Ideal for single-liquid seals incorporating two hard faces and a QCD (quench containment device).
- Single point lubricator allows each seal quench cavity to be operated independent of other equipment.
- Used when no quench water is available, ideal for frequent automatic start/stop sequences and installations at remote field locations.
- DS-920-OG Flowserve lubricant resists breakdown when mixed with pumpage, water or containments; optional DS-460-F lubricant is approved by USDA for incidental food contact.
- Customized dispensing rate for each application; provides precise lubrication for varying operating conditions.
- Long term equipment storage lubricates mechanical seal faces and allows hand rotation of equipment shafts.

Specifications

Mini Luber Dimension

117.5 mm x 79.5 mm diameter
(4.625" high x 3.125")
nipple thread 1/4" NPT

Mini Luber Capacity

125 cc (approximately 4 oz.)

Jumbo Luber Dimensions

168.5 mm x 120.5 mm diameter
(6.625" high x 4.750")
nipple thread 1/2" NPT

Jumbo Luber Capacity

475 cc (approximately 16 oz.)

SLD Seal Support System Kit

Order Part Code	Description
MLB32752919	Mini Luber DS-920-0G Kit (one each of item: 06, 08, 09, 31)
MLB32752920	Jumbo Luber DS-920-0G Kit (one each of item: 07, 08, 09, 31)
MLB32752925	Mini Luber DS-460-F Kit (one each of item: 23, 08, 21, 31)
MLB32752926	Jumbo Luber DS-460-F Kit (one each of item: 24, 08, 21, 31)

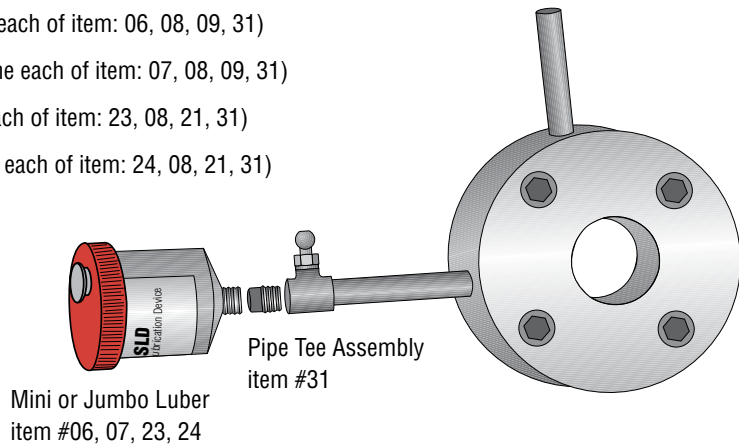

SLD Parts

Item No.	Order Part Code	Description
06	MLB32752906	Mini Luber 125 cc, DS-920-0G
07	MLB32752907	Jumbo Luber 475 cc, DS-920-0G
08	MLB32752908	Manual Grease Gun
09	MLB32752909	14.5 oz. Grease Cartridge, DS-920-0G
21	MLB32752921	14.5 oz. Grease Cartridge, DS-460-F
23	MLB32752923	Mini Luber 125 cc, DS-460-F
24	MLB32752924	Jumbo Luber 475 cc, DS-460-F
31	MLB32752931	Pipe Tee Assembly

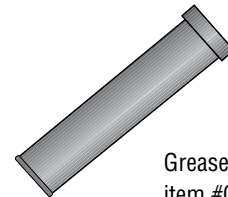
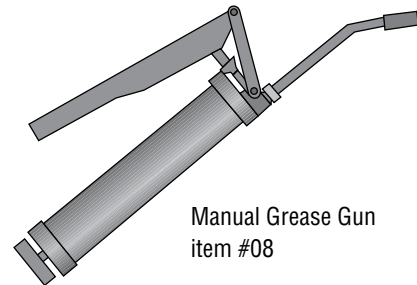

Operating Parameters

Maximum process fluid temperature	80°C (175°F)
Atmospheric temperature range	-20°C to 55°C (-4°F to 130°F)

Note: For arrangements and operating parameters not listed, contact your local Flowserve Representative.

FSD148eng REV 08-12 Printed in USA

To find your local Flowserve representative
and find out more about Flowserve Corporation visit
www.flowserve.com

Flowserve Corporation has established industry leadership in the design and manufacture of its products. When properly selected, this Flowserve product is designed to perform its intended function safely during its useful life. However, the purchaser or user of Flowserve products should be aware that Flowserve products might be used in numerous applications under a wide variety of industrial service conditions. Although Flowserve can provide general guidelines, it cannot provide specific data and warnings for all possible applications. The purchaser/user must therefore assume the ultimate responsibility for the proper sizing and selection, installation, operation, and maintenance of Flowserve products. The purchaser/user should read and understand the Installation Instructions included with the product, and train its employees and contractors in the safe use of Flowserve products in connection with the specific application.

While the information and specifications contained in this literature are believed to be accurate, they are supplied for informative purposes only and should not be considered certified or as a guarantee of satisfactory results by reliance thereon. Nothing contained herein is to be construed as a warranty or guarantee, express or implied, regarding any matter with respect to this product. Because Flowserve is continually improving and upgrading its product design, the specifications, dimensions and information contained herein are subject to change without notice. Should any question arise concerning these provisions, the purchaser/user should contact Flowserve Corporation at any one of its worldwide operations or offices.

USA and Canada

Kalamazoo, Michigan USA
Telephone: 1 269 381 2650
Telefax: 1 269 382 8726

Europe, Middle East, Africa

Roosendaal, The Netherlands
Telephone: 31 165 581400
Telefax: 31 165 554590

Asia Pacific

Singapore
Telephone: 65 6544 6800
Telefax: 65 6214 0541

Latin America

Mexico City
Telephone: 52 55 5567 7170
Telefax: 52 55 5567 4224