



# *USER INSTRUCTIONS*

## *Valtek Control Products Spring Cylinder Linear Actuators*

*FCD VLENIM0002-00-AQ - 10/14 (Replaces VLAIM002)*

## *Installation Operation Maintenance*



## GENERAL INFORMATION

The following instructions are designed to assist in installing, troubleshooting and servicing Valtek spring cylinder actuators. Product users and maintenance personnel should thoroughly review this bulletin prior to installing, operating or disassembling the actuator. Separate installation, operation and maintenance instructions cover additional features (such as hand-wheels, limit stops, fail-safe systems or limit switches).

This publication does not contain information on Flowserve positioners. Refer to the appropriate installation operation and maintenance instructions for installing, maintaining, troubleshooting, calibrating and operating Flowserve positioners.

To avoid possible injury to personnel or damage to valve parts, **WARNING** and **CAUTION** notes must be strictly followed. Modifying this product, substituting non-factory or inferior parts or using maintenance procedures other than outlined could drastically affect performance, void product warranties and be hazardous to personnel and equipment.

- ▲ **WARNING:** Standard industry safety practices must be followed when working on this or any process control product. Specifically, personal protection and lifting devices must be used as warranted.

## Unpacking

While unpacking the actuator, check packing list against materials received. Lists describing the actuator and accessories are included in each shipping container.

1. Position the lifting straps and hoist to avoid damage to the tubing and mounted accessories when lifting the actuator from the shipping container.
  - ▲ **WARNING:** When lifting an actuator with lifting straps through the yoke legs, be aware the center of gravity may be above the lifting point. Therefore, support must be given to prevent the actuator from rotating or causing serious injury to personnel or damage to nearby equipment.
2. Contact your shipper immediately in the event of shipping damage.
3. Contact your Flowserve representative for any problems.

## Installation

- 2 Prior to installation, make sure adequate overhead clearance for the actuator is provided to allow for proper removal from the valve body and for proper maintenance. Refer to Table 1.

**NOTE:** If the actuator is attached to a valve body assembly, see Installation, Operation, Maintenance Instructions 1 for overhead clearances.

**Table 1: Overhead Clearance for Disassembly**

Actuator Size	Minimum Clearance
25	6 inches
50	8 inches
100,200,300 400,500,600	9 inches

1. Connect the air supply and instrument signal air lines to the two appropriately marked connections on the positioner. Since both the cylinder and positioner are suitable for 150 psi air supply, an air regulator should not be used unless the supply exceeds 150 psi.

**NOTE:** In some cases, air supply must be limited to 100 psi rather than 150 psi; this will be indicated by a sticker found near the upper air port on the cylinder.

- ▲ **WARNING:** To avoid personal injury or equipment damage, do not exceed recommended supply pressure.
2. Installation of an air filter on the supply line is recommended.
  3. Use a soap solution to make sure all air connections are leak free.

## MAINTENANCE

At least once every six months, check for proper operation by following the preventative maintenance steps outlined below. These steps can be performed while the actuator is in service and, in some cases, without interrupting service. If an internal problem is suspected with the actuator, refer to the “Disassembly and Reassembly” section.

1. Examine the actuator for damage caused by corrosive fumes and process drippings.
2. Clean the actuator and repaint any areas of severe oxidation.
3. If possible, stroke the actuator and check for smooth, full-stroke operation.
  - ▲ **WARNING:** To avoid serious injury, keep hands, hair and clothing away from all moving parts while operating the actuator.
4. Make sure positioner mounting bolts, linkage and stem clamp are securely fastened.
5. Ensure all accessories, brackets and associated bolting are securely fastened.
6. If possible, remove air supply and observe actuator for correct fail-safe action.
7. Check rubber bellows for wear.

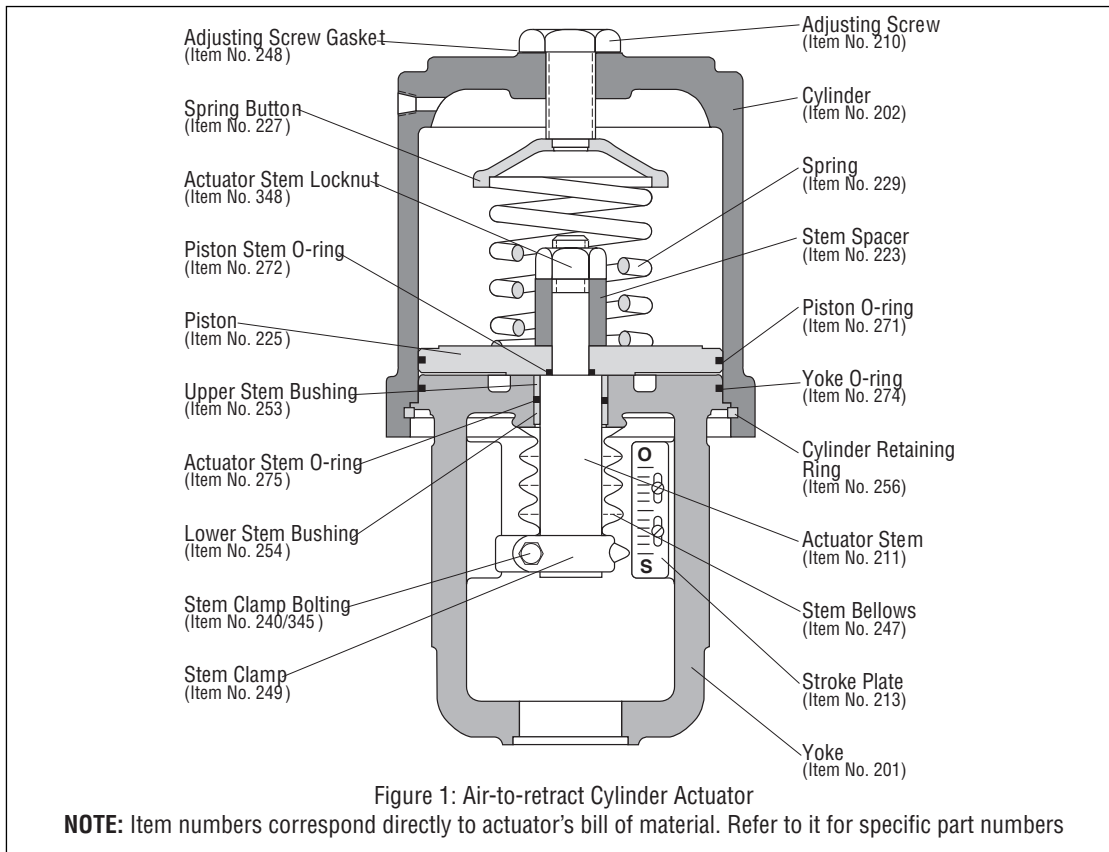

8. Spray soap solution around the cylinder retaining ring, the adjusting screw and the lower actuator stem bushing to check for air leaks through the O-rings and gasket.
9. Clean any dirt or foreign material from the actuator stem.
10. If an air filter is supplied, check and replace cartridge as necessary.

**CAUTION:** Do not use a screwdriver or bar to turn the adjusting screw; instead, use a wrench on the flats of the screw.

**WARNING:** To avoid serious personal injury, relieve the spring compression before further disassembly. The cylinder could possibly fly off the yoke when removing the cylinder retaining ring.

## DISASSEMBLY AND REASSEMBLY

### Disassembling the Actuator

Refer to Figures 1 through 5 to disassemble the cylinder actuator.

1. Shut off air supply. If the actuator is installed on a Valtek valve, remove the actuator per Installation Operation and Maintenance Instructions 1. If installed on other valves, remove the yoke to bonnet connections, loosen stem clamp bolt and turn actuator off of plug stem threads.

**WARNING:** To avoid serious injury, depressurize the line to atmospheric pressure and drain all fluids before working on the actuator.

2. Disconnect all tubing. Remove stem clamp and stem bellows from the actuator stem.
3. Relieve spring compression completely by removing the adjusting screw. Remove adjusting screw gasket from adjusting screw.

4. Remove the cylinder retaining ring from the groove at the base of the cylinder by using two screwdrivers. Insert one screwdriver in slot found in the ring and pry the ring from the groove. Use the other screwdriver to help work the ring out of the cylinder groove.

5. Pull the cylinder off the yoke and piston; some O-ring resistance may be felt.

**WARNING:** To avoid serious personal injury, do not use air pressure to remove the cylinder. The cylinder could possibly fly off the yoke.

6. For heavy-duty spring designs using a spring cap (see Figure 4), remove the spring cap and cap O-ring from the cylinder.
7. For air-to-extend configurations, slowly loosen and remove the actuator stem locknut. Be certain the piston follows the stem locknut up the actuator stem and does not bind on the actuator stem. Remove the actuator stem

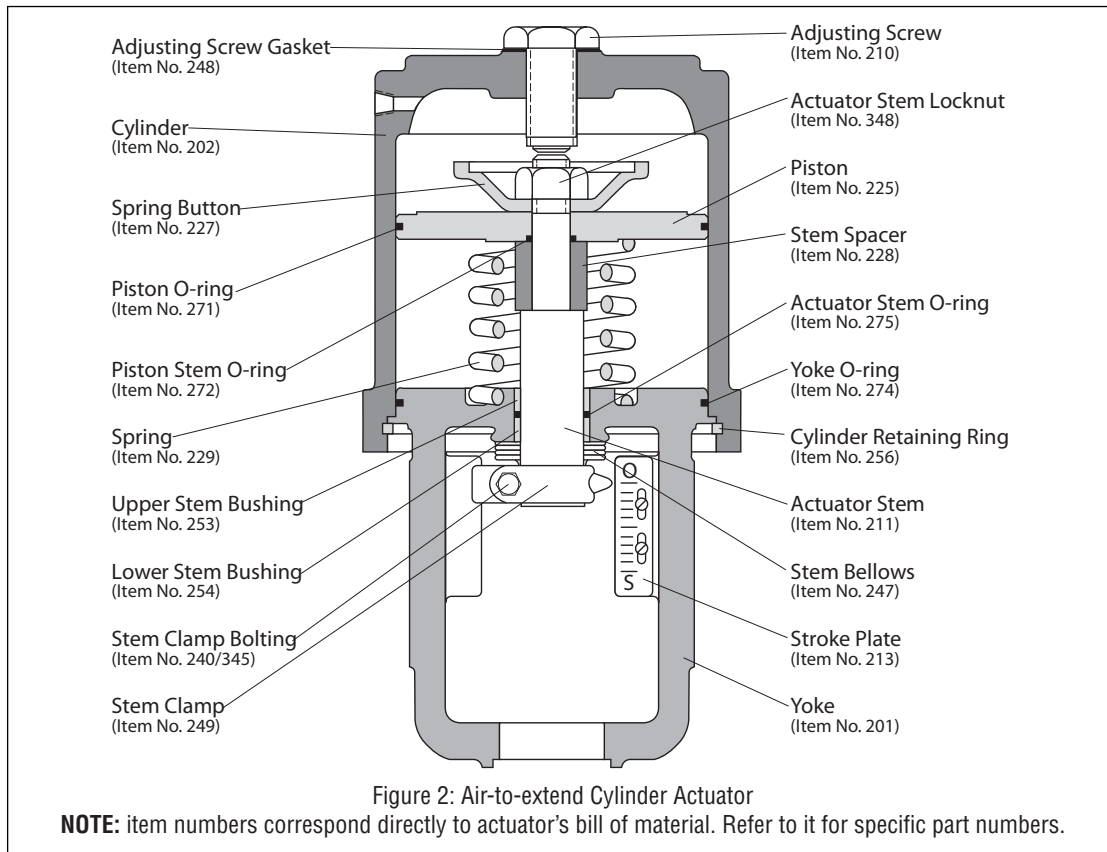

**NOTE:** The dual, heavy-duty spring configuration (Figure 3) has two springs, one inside the other. Remove both springs during this step.

8. Remove the piston O-ring, piston stem O-ring and yoke O-ring.
9. Remove the actuator stem O-ring.

**NOTE:** The upper and lower stem bushings are pressed into the yoke. Removal of the bushings to replace the actuator stem O-ring is unnecessary.

10. Use appropriately sized press to push worn or damaged bushings out of yoke.

## Reassembling the Actuator

To reassemble the cylinder actuator, refer to Figures 1 through 5:

1. All O-rings should be replaced. New O-rings should be lubricated with a silicone lubricant (Dow Corning 55M or equivalent). Silicone O-rings must be lubricated with Magnalube-G lubricant or equivalent. Do not use silicone lubricant on silicone O-rings.
2. Thoroughly clean all internal parts before beginning assembly. Lubricate cylinder wall with silicone lubricant.
3. Lubricate the outside of the replacement bushings if the stem bushings have been removed. Press a new lower stem bushing into the actuator stem bore in the yoke until it bottoms out. Press

the upper stem bushing into the bore until it is flush with the top of the yoke (refer to Figures 1 or 2).

4. Replace the actuator stem O-ring and yoke O-ring.
5. Reassemble the piston, piston stem O-ring and stem spacer on the actuator stem according to the proper air-action (refer to either Figure 1 or 2). Replace the piston O-ring. Air-to-extend configurations require the spring button to be stored under actuator stem locknut. Tighten the locknut firmly.

**NOTE:** When reassembling heavy-duty, spring design actuators, the spring guide must be first inserted under the actuator stem locknut (see Figures 3 and 4).

6. For air-to-extend configurations, place the spring under the piston and insert the actuator stem through the yoke, being careful not to pinch the actuator stem O-ring or gall the stem and stem bushings. For air-to-retract configurations, insert the actuator stem through the yoke and place the spring(s) and spring button above the piston.
7. Replace the cap O-ring and install the spring cap in the cylinder when using heavy-duty spring designs using spring caps (see Figure 4).
8. Install the cylinder, making sure the yoke is pushed deeply enough into the cylinder to allow the cylinder retaining ring to be installed. Care should be taken not to scar or cut the piston and yoke O-rings.

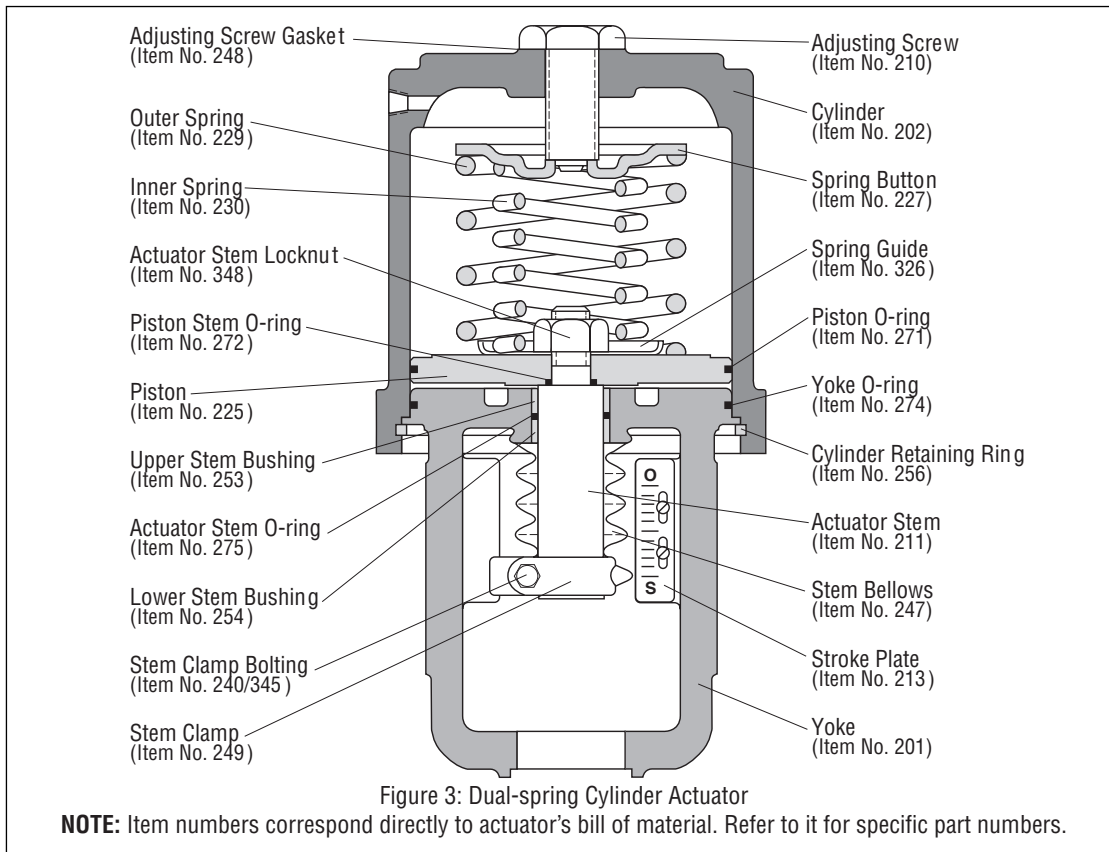

9. Re-insert the cylinder retaining ring by until it snaps in place. Use a hammer and drift punch to lightly tap the retaining ring in the groove.

**▲ WARNING:** To avoid personal injury, the cylinder retaining ring must be solidly in place. The cylinder could possibly fly off when pressurized. Be careful not to pinch or cut fingers on the square edges of the retaining ring during installation.

10. Reinstall the adjusting screw using a new adjusting screw gasket.

**NOTE:** Be certain the hole in the spring button is directly centered under the adjusting screw hole in the cylinder on air-to-retract configurations.

11. Tighten the adjusting screw enough to provide an air seal with the gasket. Do not over tighten.

12. Reinstall the stem bellows and stem clamp.

**NOTE:** To ensure maximum clamping strength when installing the stem clamp, make sure the stem clamp bolting is perpendicular to one of the slots machined into the actuator stem. 13. Apply air over the piston. Tighten the stem clamp bolting with the stem clamp adjusted to point at the closed position of the stroke indicator plate.

**NOTE:** If the actuator is installed on a Flowserve valve, refer to Installation, Operation, Maintenance Instructions 1 for correct plug stem thread engagement.

14. Reconnect tubing, supply and signal lines.

## Reversing the Air-action

To change the air action from air-to-retract to air-to-extend, or vice versa, refer to Figures 1, 2 or 5:

**NOTE:** Heavy-duty spring actuators are not reversible.

1. Disassemble the actuator according to the "Disassembling the Actuator" section.
2. For air-to-retract action, reassemble the actuator with stem spacer and spring button over the piston.
3. For air-to-extend action, reassemble with spring and stem spacer below the piston and with the spring button stored above the piston.
4. Reassemble the actuator according to the "Reassembling the Actuator" section.
5. The positioner must also be reversed. See the appropriate positioner maintenance instructions.

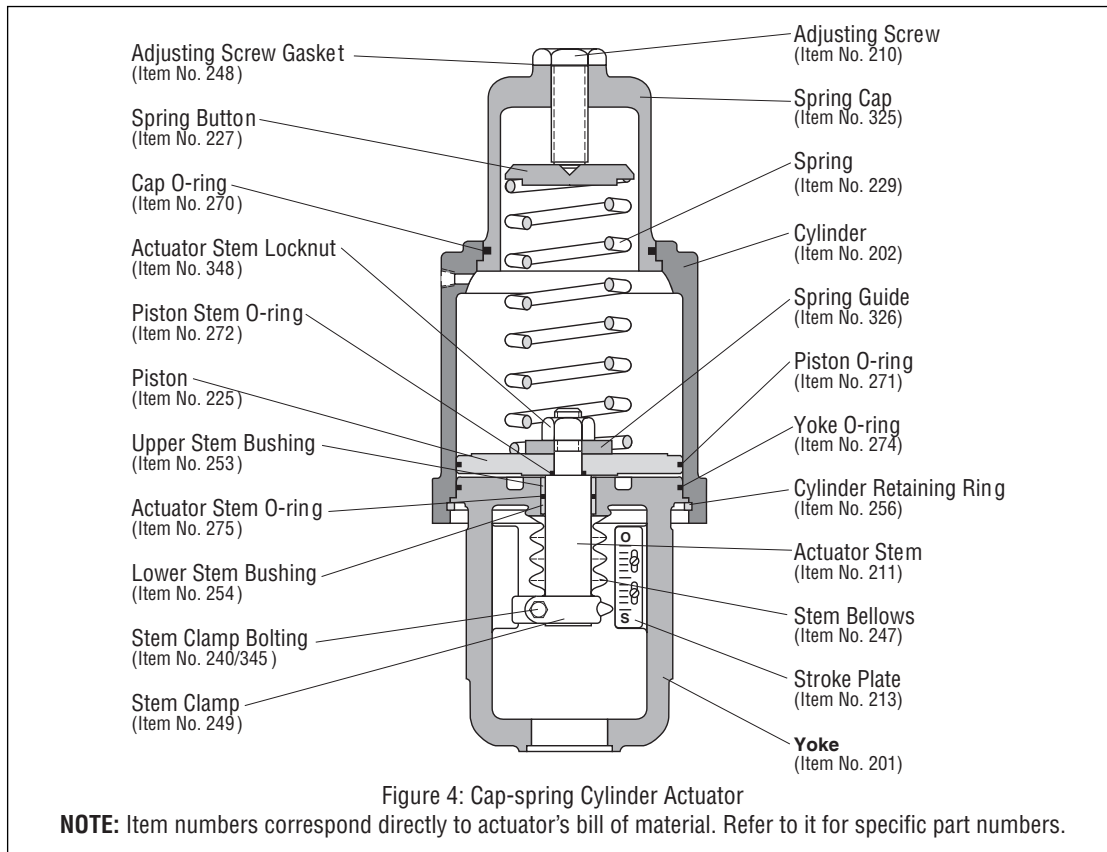

## Troubleshooting

Problem	Probable Cause	Corrective Action
High air consumption or leakage	Leaks in the air supply or instrument signal system	Tighten connections and replace any leaking lines
	Malfunctioning positioner	Refer to appropriate positioner maintenance bulletin
	Leaks through O-rings or adjusting screw gasket	Replace O-rings or gasket
Actuator does not move to fail position upon loss of air supply pressure	Air pressure in cylinder not venting because of faulty positioner	Refer to appropriate positioner maintenance bulletin
	Spring failure	Replace spring
	Internal valve problem	Refer to valve's maintenance bulletin
Jerky or sticking stem travel	Insufficient air supply pressure	Check air supply and any filters or regulators; check for leaking O-rings
	Unlubricated cylinder wall	Lubricate cylinder wall with silicone lubricant
	Worn or damaged stem bushings	Check actuator stem for damage; replace actuator stem, O-ring, and stem bushings, if necessary
	Improperly assembled spring	Disassemble actuator and check cylinder and piston for damage; reassemble actuator correctly
	Internal valve problem	Refer to valve's maintenance instructions

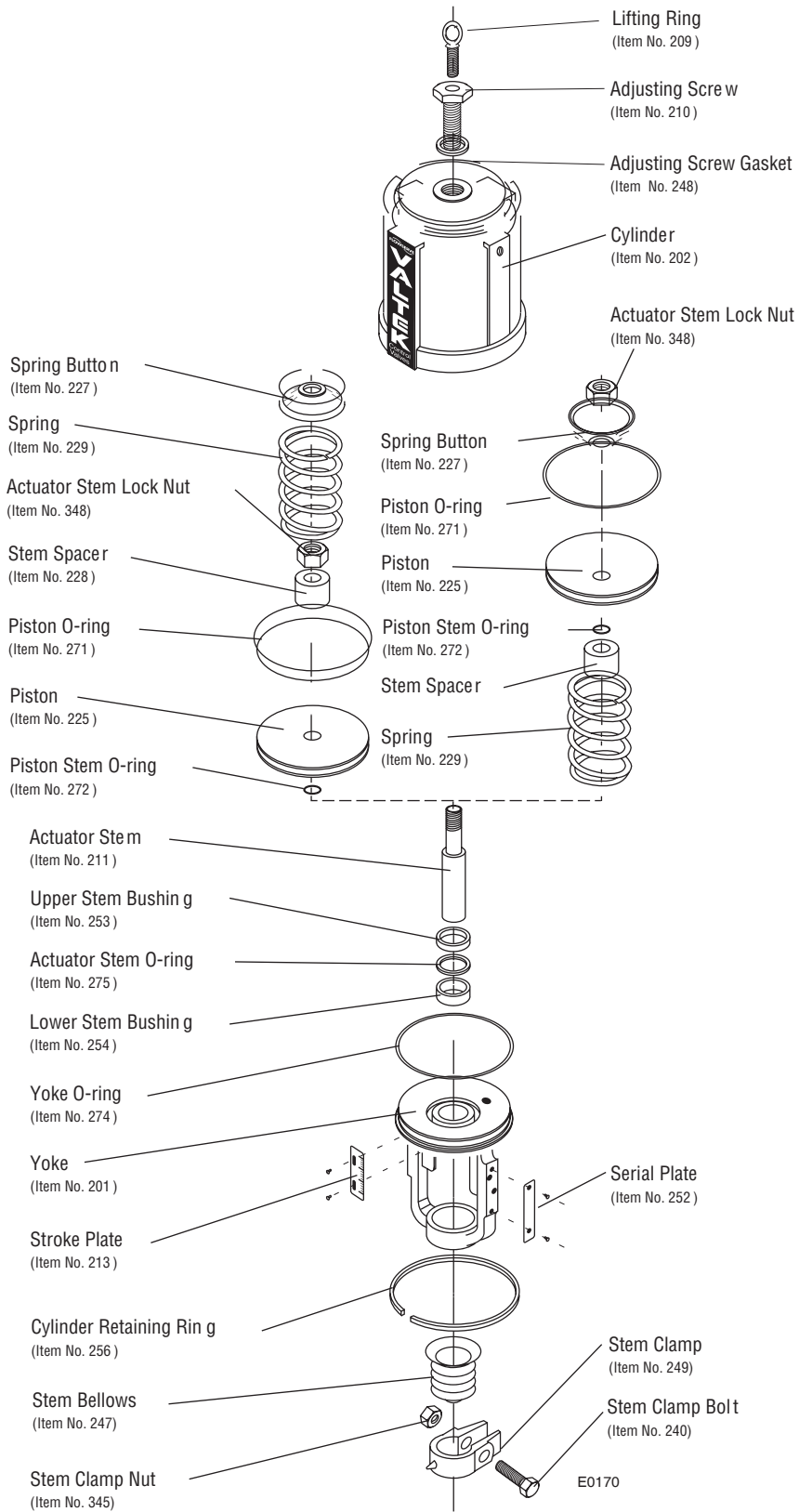

Figure 5: Exploded View, Spring Cylinder Actuator

**NOTE:** Item numbers correspond directly to actuator's bill of material. Refer to it for specific part numbers.



FCD VLENIM0002-00-AQ Printed in USA. November 2014

**To find your local Flowserve representative**  
or for more information about Flowserve Corporation, visit  
[www.flowserve.com](http://www.flowserve.com).

Flowserve Corporation has established industry leadership in the design and manufacture of its products. When properly selected, this Flowserve product is designed to perform its intended function safely during its useful life. However, the purchaser or user of Flowserve products should be aware that Flowserve products might be used in numerous applications under a wide variety of industrial service conditions. Although Flowserve can (and often does) provide general guidelines, it cannot provide specific data and warnings for all possible applications. The purchaser/user must therefore assume the ultimate responsibility for the proper sizing and selection, installation, operation, and maintenance of Flowserve products. The purchaser/user should read and understand the Installation Operation Maintenance (IOM) instructions included with the product, and train its employees and contractors in the safe use of Flowserve products in connection with the specific application.

While the information and specifications contained in this literature are believed to be accurate, they are supplied for informative purposes only and should not be considered certified or as a guarantee of satisfactory results by reliance thereon. Nothing contained herein is to be construed as a warranty or guarantee, express or implied, regarding any matter with respect to this product. Because Flowserve is continually improving and upgrading its product design, the specifications, dimensions and information contained herein are subject to change without notice. Should any question arise concerning these provisions, the purchaser/user should contact Flowserve Corporation at any one of its worldwide operations or offices.

© 2014 Flowserve Corporation, Irving, Texas, USA. Flowserve is a registered trademark of Flowserve Corporation.

#### **USA**

Flowserve Flow Control Division  
1350 N. Mt. Springs Parkway  
Springville, UT 84663  
USA  
Phone: +1 801 489 8611  
Fax: +1 801 489 3719

#### **Austria**

Flowserve Control Valves GmbH  
Kasernengasse 6  
9500 Villach  
Austria  
Phone: 43 (0) 4242 41 181 0  
Fax: 43 (0) 4242 41181 50  
France  
Flowserve France S.A.S.  
BP 60 63307 Thiers Cedex  
France  
Phone: 33 4738 04266  
Fax: 33 4738 01424

#### **India**

Flowserve India Controls Pvt Ltd.  
Plot # 4, 1A, Road #8 EPIP  
Whitefield  
Bangalore, Karnataka, 560066  
India  
Phone: 91 80 40146200  
Fax: 91 80 28410286

#### **China**

Flowserve Fluid Motion and  
Control (Suzhou) Co., Ltd.  
No. 35, Baiyu Road  
Suzhou Industrial Park, Suzhou  
Jiangsu Province, P.R. 215021  
China  
Phone: 86 512 6288 8790  
Fax: 86 512 6288 8736

#### **Singapore**

Flowserve Pte. Ltd.  
12 Tuas Avenue 20  
Republic of Singapore 638824  
Phone: 65 6879 8900  
Fax: 65 6862 4940

#### **Saudi Arabia**

Flowserve Abahsain Flow Control  
Co., Ltd.  
Makkah Road, Phase 4  
Plot 10 & 12, 2nd Industrial City  
Dammam, Kingdom of Saudi  
Arabia  
Phone: +966 3 857 3150 ext. 243  
Fax: +966 3 857 4243