

The V series bevel gearboxes offer an extensive range of thrust and torque outputs for multi-turn applications such as gate and globe valves, and slide gates. Applications for weatherproof or temporary submersion (IP67) service can be accommodated. Optional spur gear attachments reduce the input torque required, resulting in lower handwheel rim pull for opening and closing operations.

The V series ductile iron housing provides strength and durability. The drive sleeve, bevel pinion shaft, and spur gear reduction shafts are roller bearing-supported, delivering high mechanical advantage and long life. Excellent sealing of mating surfaces provides reliable environmental protection. Ambient temperatures to -35°C are achieved with the standard lubricant.

Features and Benefits

- Weatherproof and temporary submersion construction (IP67)
- Maintenance-free
- Input flanges machined in accordance with MSS SP-102, with keyed input shaft
- Mounting flanges are MSS as standard, with ISO available as an option
- Splined, bronze alloy stem nut is removable from the drive sleeve for thread machining
- High strength bevel pinion and ring gear
- Roller bearing supported for high mechanical advantage
- Ductile iron enclosure

The V and V_H series bevel gearboxes, when motorized by MX, L120, or SMB actuators, provide effective and reliable solutions for multi-turn valve, sluice gate, and slide gate applications.



- Optional V_H design available for high thrust and torque applications with thrust output to 2.585 million lbs (11 500 kN), and torque output to 104,734 ft. lbs (142 000 kN)
- -35°C to 90°C (-31°F to 194°F) temperature range for continuous operation, with -50°C (-58°F) available

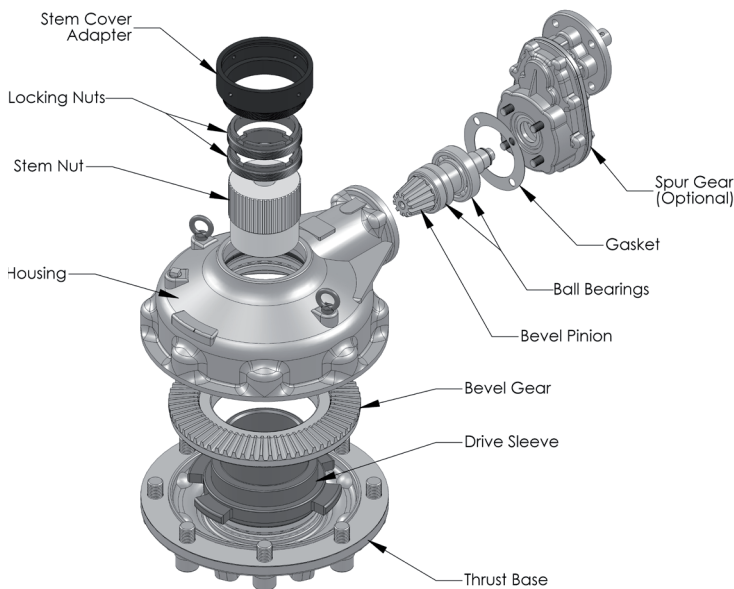

Exploded View V Series

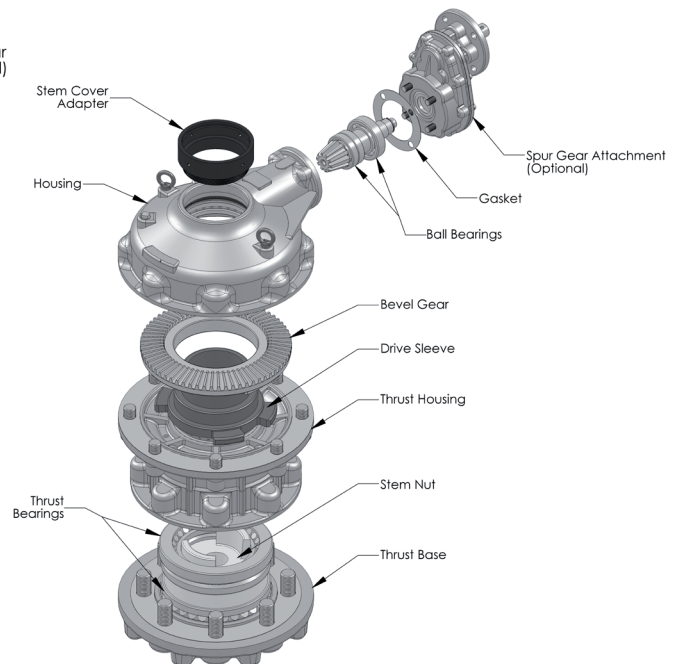

Exploded View V_H Series

Ratings

Gearbox	Ratio	Mechanical Advantage	Threaded Stem Capacity		Output Thrust Rating		Output Thrust Rating		Input Torque for Output Thrust Rating	
			Inches	mm	lbs	kN	ft lbs	Nm	ft lbs	Nm
V0	3.25:1	3.1	1.81	46	28 550	127	442	600	143	194
V0-1S	6.5:1	6							74	100
V0-1SD	13:1	11.7							38	51
V1	3.5:1	3.3	2.17	55	31 698	141	723	980	134	182
V1-1S	7:1	6.3							70	95
V1-1SD	14:1	12.6							35	48
V2	4:1	3.8	2.44	62	42 714	190	1106	1500	116	158
V2-1S	10.13:1	9.3							48	65
V2-1SD	25.67:1	23.7							19	25
V2H	4:1	3.8	2.56	65	242 800	1080	2139	2900	116	158
V3	5:1	4.8	2.83	72	64 745	288	1844	2500	92	125
V3-1S	12.67:1	11.7							38	51
V3-1SD	32:1	29.6							15	20
V3H	5:1	4.8	3.15	80	384 400	1710	3319	4500	92	125
V35	5.5:1	5.2	3.35	85	78 683	350	2581	3500	85	115
V35-1S	16.5:1	15.2							29	39
V35-1SD	49.5:1	45.6							10	13
V35H	5.5:1	5.2	3.74	95	550 800	2450	5163	7000	85	115
V4	6:1	5.7	3.86	98	89 924	400	3835	5200	78	105
V4-1S	18:1	16.6							27	36
V4-1SD	54:1	49.8							9	12
V4H	6:1	5.7	4.33	110	651 900	2900	7228	9800	78	105
V5	6.56:1	6.2	4.33	110	114 653	510	5753	7800	71	97
V5-1S	22.94:1	21.1							21	28
V5-1SD	80.31:1	74							6	8
V5H	6.56:1	6.2	5.12	130	786 800	3500	11 063	15 000	71	97
V55	7:1	6.7	4.72	120	337 213	1500	7671	10 400	66	90
V55-1S	24.5:1	22.6							20	27
V55-1SD	85.75:1	79							6	8
V55H	7:1	6.7	5.51	140	944 197	4200	14 014	19000	66	90
V6	7:1	6.7	5.12	130	519 309	2310	9588	13 000	66	90
V6-1S	28:1	25.8							17	23
V6-1SD	112:1	103.2							4	6
V6H	7:1	6.7	5.91	150	1 056 600	4700	16 964	23 000	66	90
V7	7.56:1	7.2	5.91	150	562 022	2500	12 981	17 600	61	83
V7-1S	30.22:1	27.8							16	22
V7-1SD	120.89:1	111.4							4	5
V7H	7.56:1	7.2	6.69	170	1 169 000	5200	27 290	37 000	61	83
V75	8:1	7.6	6.3	160	775 591	3450	15 489	21 000	58	79
V75-1S	40:1	36.9							12	16
V75-1SD	200:1	184.3							2	3
V75H	8:1	7.6	7.48	190	1 528 701	6800	33 928	46 000	58	79
V8	8:1	7.6	7.09	180	921 717	4100	23 602	32 000	58	79
V8-1S	40:1	36.9							12	16
V8-1SD	200:1	184.3							2	3
V8H	8:1	7.6	8.46	215	1 719 800	7650	42 778	58 000	58	79
V9	8:1	7.6	7.87	200	1 225 180	5450	40 566	55 000	58	79
V9-1S	40:1	36.9							12	16
V9-1SD	200:1	184.3							2	3
V9H	8:1	7.6	9.45	240	2 113 200	9400	76 706	104 000	58	79
V10	8:1	7.6	9.06	230	2 585 300	7300	55 317	75 000	58	79
V10-1S	40:1	36.9							12	16
V10-1SD	200:1	184.3							2	3
V10H	8:1	7.6	10.63	270	2 585 300	11 500	104 734	142 000	58	79

Note: V_H gearboxes are available with single reduction and double reduction spur gear attachments.

Flowserve Corporation has established industry leadership in the design and manufacture of its products. When properly selected, this Flowserve product is designed to perform its intended function safely during its useful life. However, the purchaser or user of Flowserve products should be aware that Flowserve products might be used in numerous applications under a wide variety of industrial service conditions. Although Flowserve can (and often does) provide general guidelines, it cannot provide specific data and warnings for all possible applications. The purchaser/user must therefore assume the ultimate responsibility for the proper sizing and selection, installation, operation and maintenance of Flowserve products. The purchaser/user should read and understand the Installation Operation Maintenance (IOM) instructions included with the product, and train its employees and contractors in the safe use of Flowserve products in connection with the specific application.

While the information and specifications contained in this literature are believed to be accurate, they are supplied for informative purposes only and should not be considered certified or as a guarantee of satisfactory results by reliance thereon. Nothing contained herein is to be construed as a warranty or guarantee, express or implied, regarding any matter with respect to this product. Because Flowserve is continually improving and upgrading its product design, the specifications, dimensions and information contained herein are subject to change without notice. Should any question arise concerning these provisions, the purchaser/user should contact Flowserve Corporation at any one of its worldwide operations or offices.

© 2013 Flowserve Corporation, Irving, Texas, USA. Flowserve is a registered trademark of Flowserve Corporation.

**To find your local Limitorque representative, visit
www.limitorque.com or call USA 434 528 4400.**

United States
Flowserve Limitorque
5114 Woodall Road
Lynchburg, VA 24502 USA
Telephone: 434 528 4400
Fax: 434 845 9736

FCD LMENFL3602-01 A4 08/17 © 2013 Flowserve Corporation.