



# ***PVML*** ***Vertical In-Line Pump***

ISO 13709/API 610 (OH5)



***Experience In Motion***

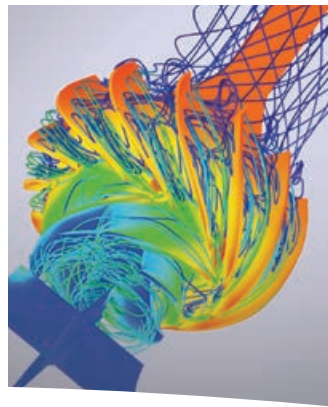

## ***Pump Supplier to the World***

*Flowserve is the driving force in the global industrial pump marketplace. No other pump company in the world has the depth or breadth of expertise in the successful application of pre-engineered, engineered, and special purpose pumps and systems.*

### ***Life Cycle Cost Solutions***

Flowserve provides pumping solutions that permit customers to reduce total life cycle costs and improve productivity, profitability and pumping system reliability.

### ***Market-Focused Customer Support***

Product and industry specialists develop effective proposals and solutions directed toward market and customer preferences. They offer technical advice and assistance throughout each stage of the product life cycle, beginning with the initial inquiry.

### ***Broad Product Lines***

Flowserve offers a wide range of complementary pump types, from pre-engineered process pumps to highly engineered and special purpose pumps and systems. Pumps are built to recognized global standards and customer specifications.

Pump designs include:

- Single-stage process
- Between bearings single-stage
- Between bearings multistage
- Vertical
- Submersible motor
- Positive displacement
- Nuclear
- Specialty

### ***Product Brands of Distinction***

*ACEC™ Centrifugal Pumps*

*Aldrich™ Pumps*

*Byron Jackson® Pumps*

*Calder™ Energy Recovery Devices*

*Cameron™ Pumps*

*Durco® Process Pumps*

*Flowserve® Pumps*

*IDP® Pumps*

*Lawrence Pumps®*

*Niigata Worthington™ Pumps*

*Pacific® Pumps*

*Pleuger® Pumps*

*Scienco™ Pumps*

*Sier-Bath® Rotary Pumps*

*TKL™ Pumps*

*United Centrifugal® Pumps*

*Western Land Roller™ Irrigation Pumps*

*Wilson-Snyder® Pumps*

*Worthington® Pumps*

*Worthington Simpson™ Pumps*

**PVML**

**Vertical In-Line Pump  
ISO 13709/API 610 (OH5)**

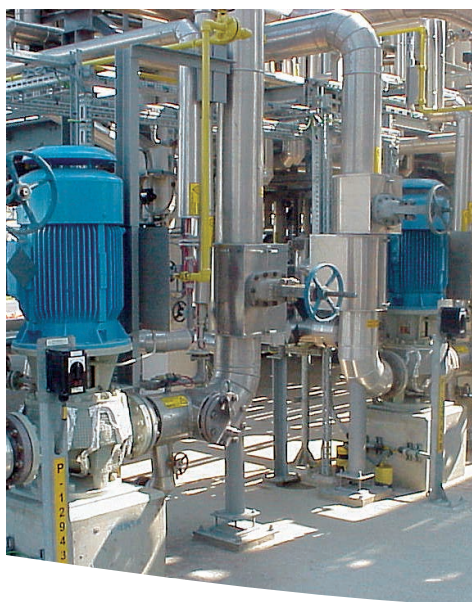

**The Choice for Precision-Set, Full Flow-Head Range, Vertical In-Line Pumping**

The PVML pump is compliant with an ISO 13709/ API 610 (OH5) and BS 4082R. This conventionally sealed in-line pump is a space-saving alternative for many overhung process pumps in upstream and downstream services. The pump features milled and interchangeable diffuser channels, which are customized for specific duty points, providing customers great flexibility in addressing changing operating parameters. A total of 150 hydraulics can be achieved with the 13 pump casings in the family.

The PVML also achieves the most stringent emissions containment. Its ISO 21049/API 682 seal chambers accommodate all mechanical seal styles, including advanced gas barrier seal technology.

**Broad Applications**

- Petroleum refining, production and distribution for on and offshore environments
- Petrochemical and heavy-duty chemical processing
- Gas industry services
- Water and general industry

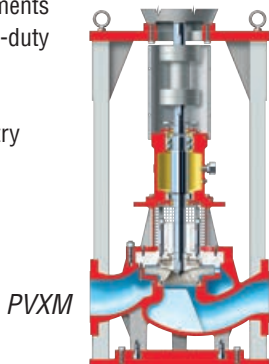

**A Recognized Industry Leader**

The Flowserve PVML family of vertical in-line pumps is recognized by customers worldwide as an industry leader for these reasons:

- Robust construction meets pressure, temperature, nozzle loading and safety considerations required by ISO 13709/API 610 and other industry or user specifications
- High pump efficiency results from optimized diffuser-impeller combinations
- Extra-low energy consumption at part load flows is made possible by specific diffuser tuning
- Variety of materials, pressure ratings and flange configurations are available to suit specific service requirements
- Unique suction box design provides low NPSH
- Sealed, dry shaft design protects the high-grade carbon steel material against corrosion.

**Complementary Pump Designs**

PVML pumps may be used with other Flowserve models of API design. These include:

- Single-stage, horizontal overhung pumps
- Single- and two-stage, between bearing pumps
- Multistage between bearing pumps

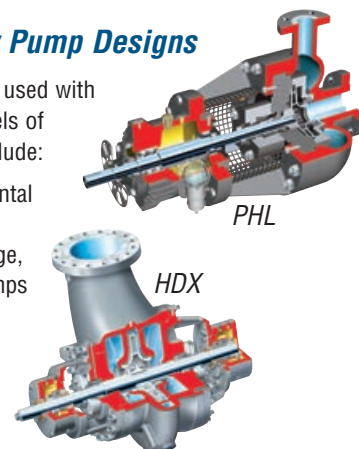

## PVML

### ISO 13709/API 610 (OH5) Vertical In-Line Pump

The PVML vertical in-line pump is an alignment-free design, since no coupling is used. The pump and motor shaft is one unit. API's 0.05 mm (0.002 in) maximum mechanical run-out is easily achieved by machined tolerances for the motor and motor support head with its registered fit.

#### Operating Parameters

- Flows to 500 m<sup>3</sup>/h (2200 gpm)
- Heads to 275 m (900 ft)
- Pressures to 40 bar (600 psi)
- Temperatures to 250°C (480°F)

#### Features and Benefits

**Customized Hydraulics** generate low vibration levels, high efficiencies and near-zero seal emissions. This results in low total cost of ownership, long MTBF, and extended MTBPM with low maintenance cost.

**Cartridge Seal Mounting** assures ease of maintenance and precise seal face setting for maximum seal life.

**ISO 21049/API 682 Seal Chamber** accommodates a wide variety of seal configurations, including dual-pressurized and unpressurized cartridge types for the most severe services. A full complement of ISO 13709/API 610 seal flush plans is available.

**Dynamically Balanced Impeller** minimizes vibration and assures smooth operation over a wide flow range.

- Casting techniques and manufacturing processes for fine finish and high efficiency
- Positively locked, anti-rotation impeller nut with threads unexposed to pumped fluid

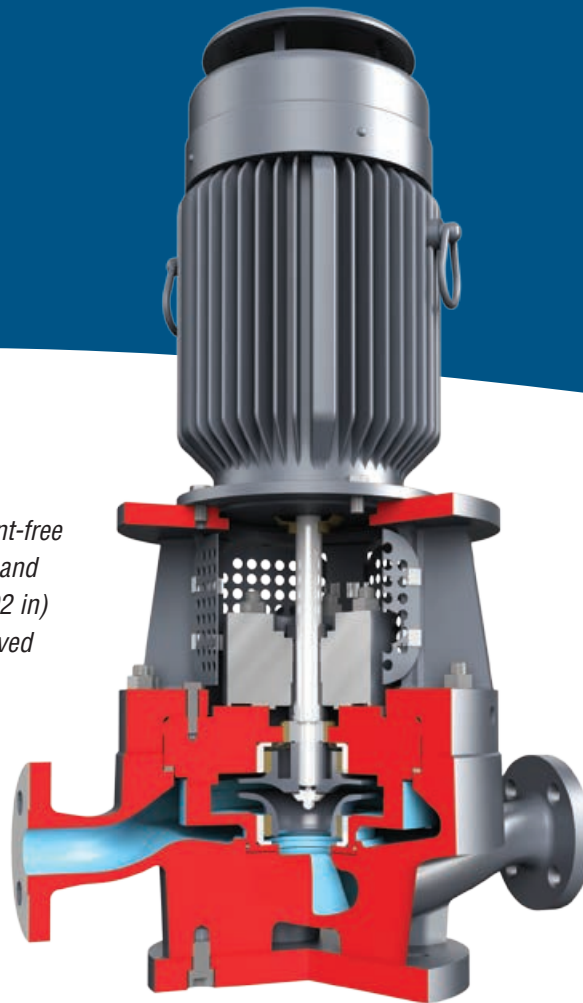

**Performance Tuning** capabilities include field hydraulic customization. Performance flexibility is easily accomplished by replacing impellers and diffusers without the need to change the casing.

**Casing and Cover** feature a metal-to-metal fit with a fully confined, controlled compression gasket to ensure proper sealing and alignment.

**Motor Support Head** machined to accept IEC motor designs and optional NEMA P-Base.

**Raised Face Flanges** are to ASME (ANSI) B16.5 for Class 300, and Class 150 and 600 are optional. Surface finish meets ISO 13709/API 610 standard. ISO and JIS drilling are available.

Diffuser/Impeller Combination

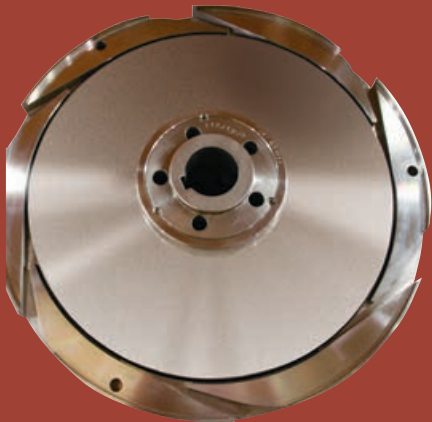

Small Footprint

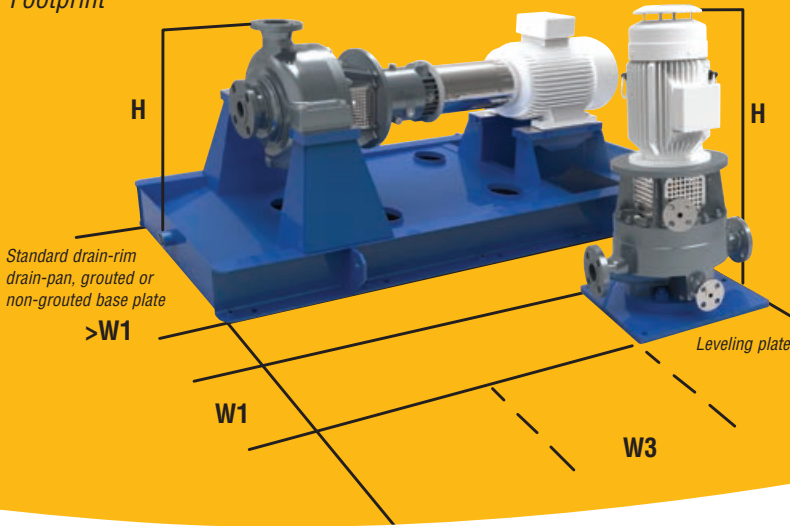

Milled Diffuser for Customized BEP Fits

Diffuser technology provides:

- Low vibration level at any flow
- Minimum continuous flows at 10–20% of BEP
- Very low shaft deflection and virtually zero radial hydraulic thrust at any flow rate

Dow Chemical has recognized these benefits by bestowing the PVML with its Dow Energy Prize, awarded to showcase innovations in energy efficiency.



Minimal Floor Space

Compared to a similar OH2 pump, the PVML provides a much smaller footprint. This makes it ideal for installations where floor space is limited. Additionally, the simple drop-in assembly makes maintenance much easier in tight, confined areas.

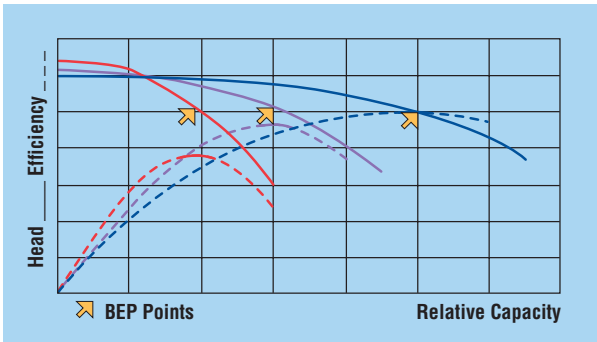

**Options and Technical Data**

*HWM API OH3 Flexible Coupled*

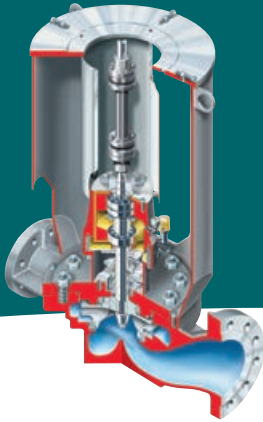

*WM2 API OH5 Extended Motor Shaft*

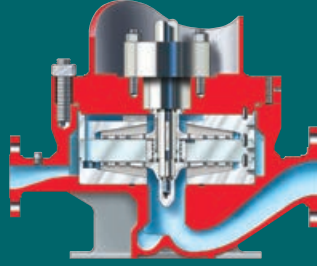

*MSP API OH4 Rigid Coupled Variable Speed*



API Code	Design Type	Single-Stage	Two-Stage
OH3	Flexible Coupled With Pump Bearing Housing, Diffuser Casing	PVXM	
	Flexible Coupled With Pump Bearing Housing, Low-Flow Impeller, Volute Insert	HWM	HWM2
OH4	Rigid Coupled, Fixed Speed	W	
	Rigid Coupled, Variable Speed, Low-Flow/High Head With VFD	MSP	MSP
	Rigid Coupled, Double-Suction Impeller	DSVP	
OH5	Extended Motor Shaft With Low-Flow Impeller, Volute Insert	WM	WM2
	Extended Motor Shaft Diffuser Casing	PVML	

**A Variety of Configurations**

Flowserve offers vertical in-line pumps in all configurations and sizes to meet all service conditions, preferences and budgets. Each model is fully compliant with ISO 13709/API 610, latest edition.

Options include customized hydraulics, using volute inserts/diffusers, radial blade impellers, inducers and double-suction impellers.

**PVML Range Chart**

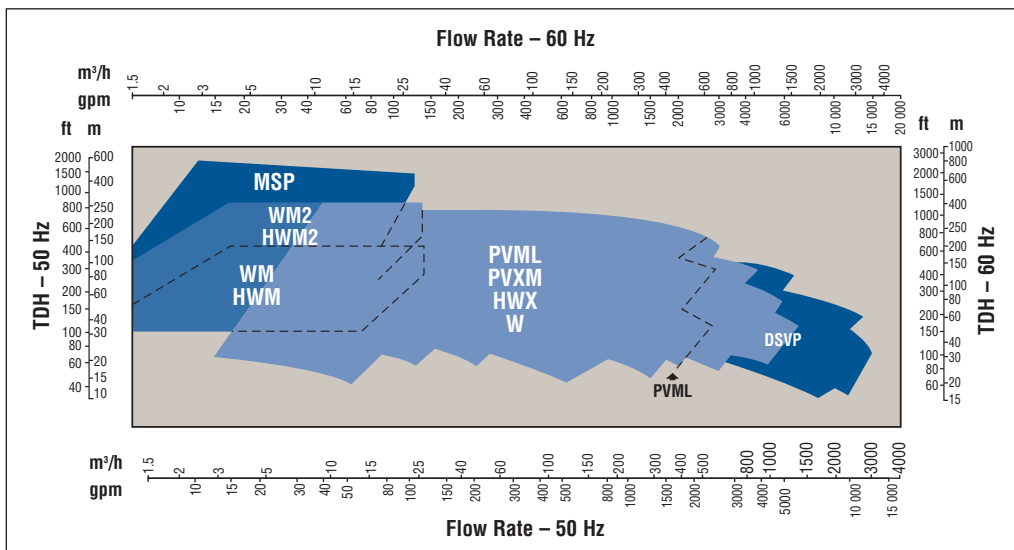

**Global Service and Technical Support**



## Life Cycle Cost Solutions

Typically, 90% of the total life cycle cost (LCC) of a pumping system is accumulated after the equipment is purchased and installed. Flowserve has developed a comprehensive suite of solutions aimed at providing customers with unprecedented value and cost savings throughout the life span of the pumping system. These solutions account for every facet of life cycle cost, including:

### Capital Expenses

- Initial purchase
- Installation

### Operating Expenses

- Energy consumption
- Maintenance
- Production losses
- Environmental
- Inventory
- Operating
- Removal

**Innovative Life Cycle Cost Solutions**

- New Pump Selection
- Turnkey Engineering and Field Service
- Energy Management
- Pump Availability
- Proactive Maintenance
- Inventory Management

### Typical Pump Life Cycle Costs<sup>1</sup>

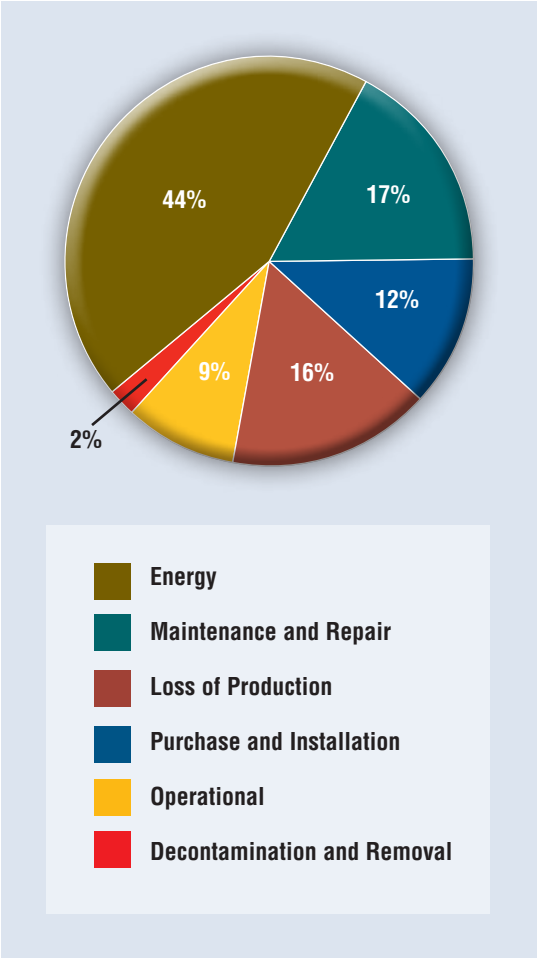

<sup>1</sup> While exact values may differ, these percentages are consistent with those published by leading pump manufacturers and end users, as well as industry associations and government agencies worldwide.

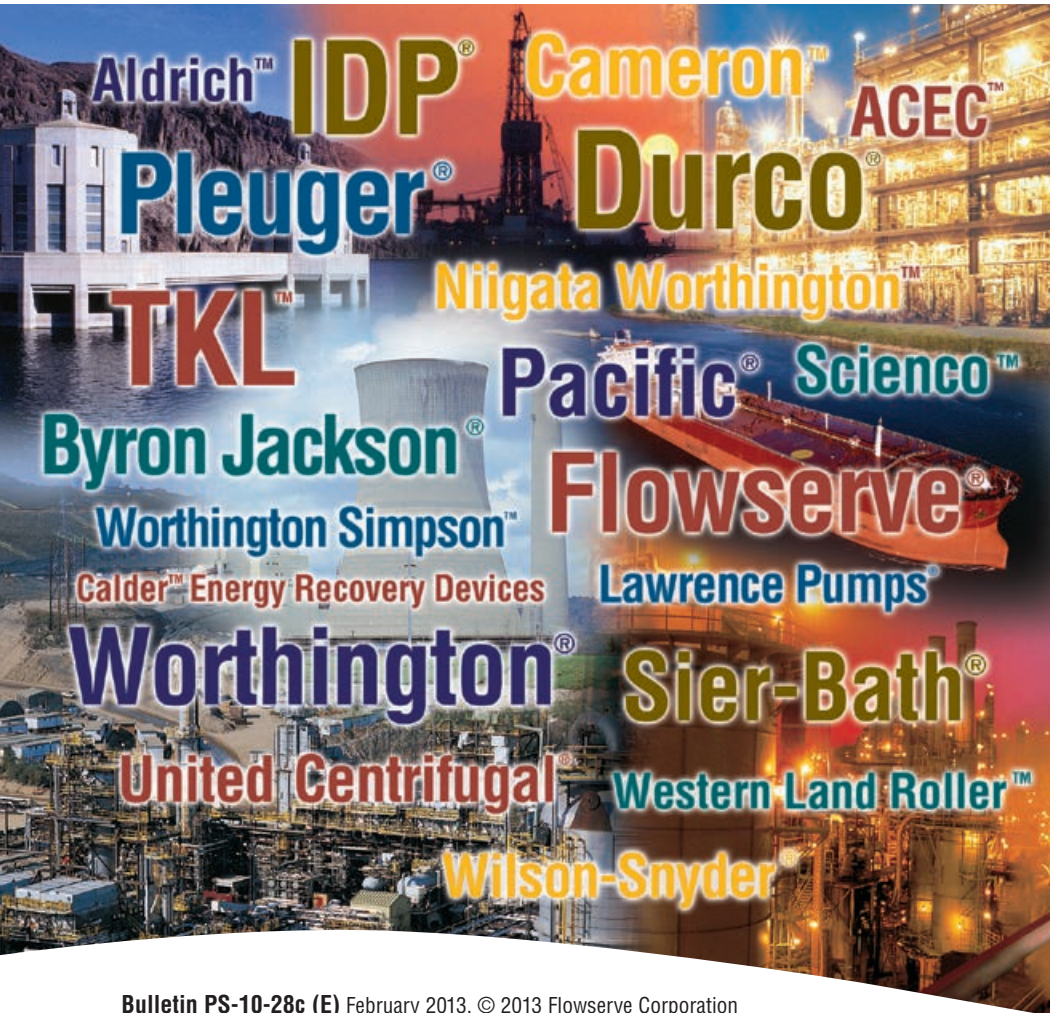

**USA and Canada**

Flowserve Corporation  
5215 North O'Connor Blvd.  
Suite 2300  
Irving, Texas 75039-5421 USA  
Telephone: +1 937 890 5839

**Europe, Middle East, Africa**

Flowserve Corporation  
Parallelweg 13  
4878 AH Etten-Leur  
The Netherlands  
Telephone: +31 76 502 8100

**Latin America**

Flowserve Corporation  
Martín Rodríguez 4460  
B1644CGN-Victoria-San Fernando  
Buenos Aires, Argentina  
Telephone: +54 11 4006 8700  
Telefax: +54 11 4714 1610

**Asia Pacific**

Flowserve Pte. Ltd.  
10 Tuas Loop  
Singapore 637345  
Telephone: +65 6771 0600  
Telefax: +65 6862 2329

Bulletin PS-10-28c (E) February 2013. © 2013 Flowserve Corporation

*To find your local Flowserve representative:*

For more information about Flowserve Corporation,  
visit [www.flowserve.com](http://www.flowserve.com) or call +1 937 890 5839.