

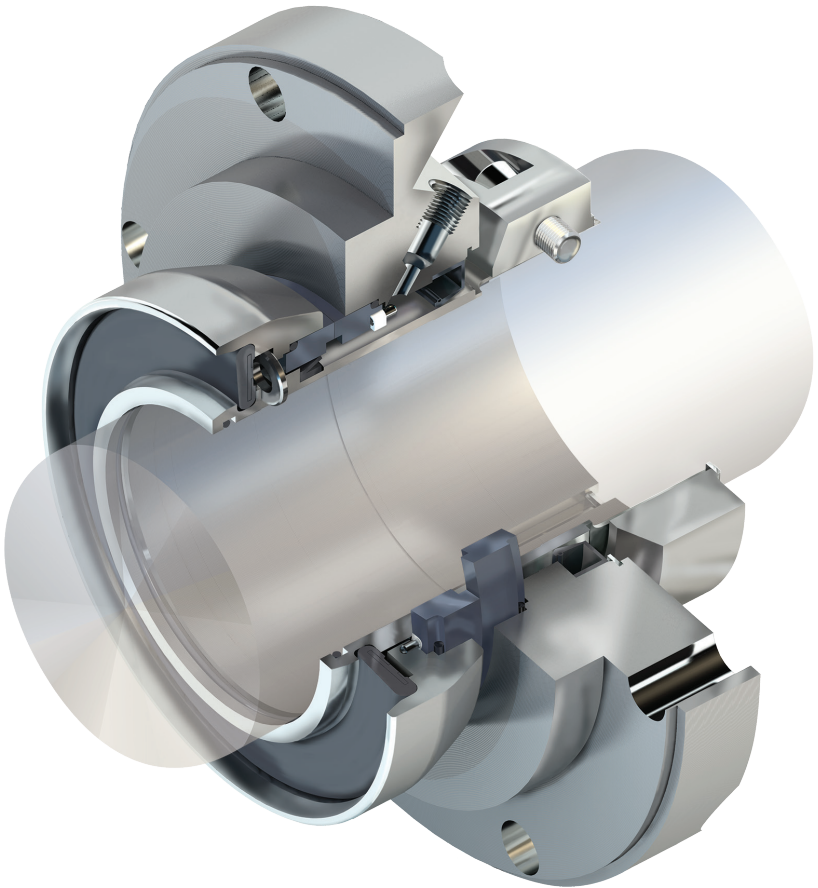

# *Installation Instructions*

## *Interseal™ SLC Series*

Self contained single cartridge  
heavy duty slurry seal



# 1 General Seal Installation Instructions

The following instructions are designed to simplify the installation of a typical SLC Cartridge Slurry Seal. See Figure 1. By reading this manual and following its guidelines, seal performance can be improved by reducing the chances of premature failure attributed to improper installation. In addition to these instructions, consult the seal assembly drawing included for your specific seal design, materials of construction, critical dimensions, and any auxiliary piping connections. If any problems arise during installation, **Do Not Try to Force Anything.**

These instructions are written for trained, experienced technicians who are familiar with the basic principles and tools involved in the installation, care and service of mechanical seals.

A complete reading of these instructions by personnel in contact with the equipment is essential to safety. Incorrect installation, operation or maintenance can result in personal injury or death to personnel and damage to the equipment.

For special problems encountered during installation, contact your nearest Flowserve Sales and Service Representative or Authorized Distributor.

## Typical SLC Cartridge

Figure 1

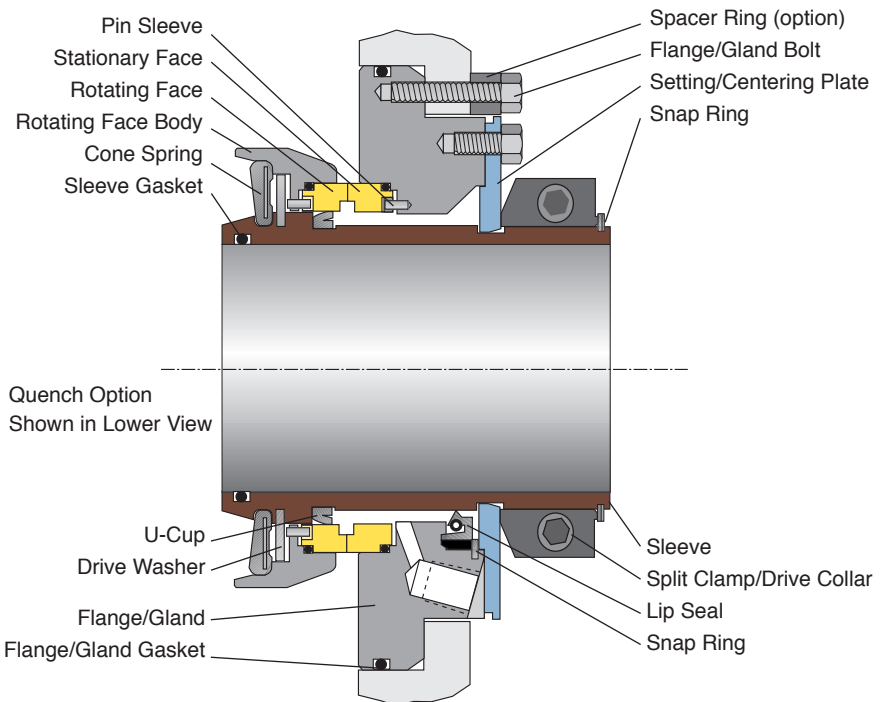

## 2 Equipment Preparation for Mechanical Seal Installation

---

- 2.1 **Follow plant safety regulations** prior to equipment disassembly:
- lock out motor/driver and valves.
  - wear designated personal safety equipment.
  - relieve any pressure in the system.
  - consult plant MSDS files for hazardous material regulations.
  - vent and drain equipment before any work is performed in the field or removed to a maintenance facility.
- 2.2 Disassemble and clean all equipment to allow access to seal installation area.
- 2.3 When converting from a packed stuffing box, replacement equipment parts may be required such as taper bore covers, liners, and high efficiency impellers. These items should specifically be designed for use with mechanical seals.

## 3 Equipment Checks

---

- 3.1 Radial and thrust bearings should be in new condition. If not, new ones should be installed into the equipment.
- 3.2 The saddle fits of the bearing assembly should be checked for abnormal wear and reconditioned if worn.
- 3.3 Ensure that all fit locations on the pedestal and adapter are clean and free from burrs.
- 3.4 Ensure that the bearing assembly is mounted correctly (central and square) to the pump pedestal and securely fastened.
- 3.5 Clean dried product, rust, and oils from the pump shaft or shaft sleeve. Remove all burrs and sharp edges from the shaft and shaft sleeve including sharp edges of keyways and threads.
- 3.6 Replace worn shaft or shaft sleeve. Ensure that the shaft or shaft sleeve has a 1.57 mm (0.062 inch) x 30 degree chamfer on the leading edge to help prevent O-ring damage during seal installation.
- 3.7 The axial end float of the equipment shaft must be set to the manufacturer's specifications. As a guide 0.05 mm (0.002 inch) per inch of shaft diameter to a maximum of 0.40 mm (0.016 inch) FIM. See Figure 2. Addition of shims or machining adjustments to the bearing end cover may be required to limit end play.

### Check Axial Shaft Travel

Figure 2

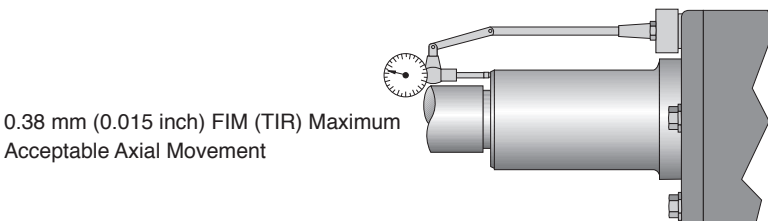

- 3.8 Shaft radial run out should be less than 0.13 mm (0.005 inch) FIM (TIR). See Figure 3. Turn shaft 360° and observe the movement. Excessive movement may indicate a bent or warped shaft that needs replacement.

### Check Radial Shaft Deflection

Figure 3

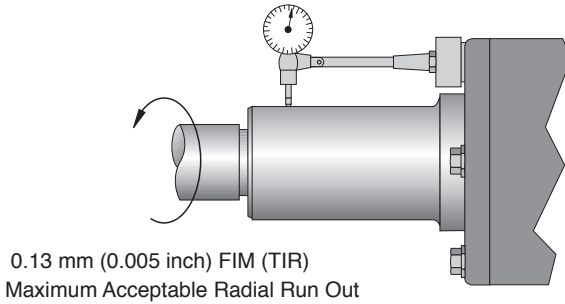

- 3.9 Make sure all seal housing bores, mounting surfaces, and fluid line connections are clean and free of burrs and sharp edges that might damage secondary sealing elements (O-rings, V-rings, or gaskets).

## 4 Wet (impeller side) Cartridge Installation

This section describes the installation of the seal cartridge from the wet or impeller side of the equipment case. If your cartridge is designed to install from the dry or bearing side of the equipment case, skip to section 5.

- 4.1 Bolt seal adapter plate to equipment case/pedestal (hand tighten only).
- 4.2 Locate the seal fit of the adapter to the shaft by use of a dial indicator or centering jig. The equipment shaft must be concentric to the seal adapter bore to within 0.25 mm (0.010 inch) FIM (TIR). See Figure 4. Seal life can vary with improper alignment; poor shaft alignment will yield poor seal life.

### Center Adapter Plate to Shaft

Figure 4

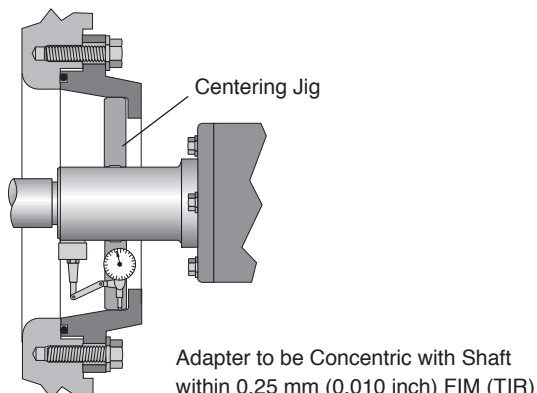

- 4.3 For adapters provided with a centering jig, simply insert the centering jig into the adapter and tighten adapter bolts, alternately adjusting the cover location until the centering jig can be removed by hand.

### Adapter Plate Mounting Surface Perpendicular to Shaft

Figure 5

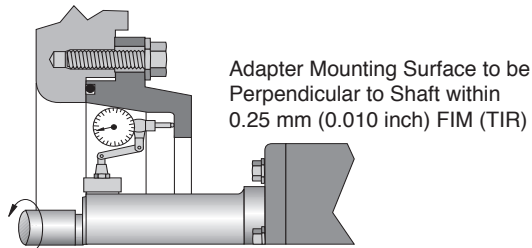

- 4.4 Dial indicate rear face of seal fit in the adapter plate. This fit must be perpendicular to the shaft within 0.25 mm (0.010 inch) FIM (TIR). See Figure 5. If surface is out of tolerance, correct by machining the faces of the locating fits. Be sure to have all fits clean of dirt, rust and/or paint.
- 4.5 Apply a light coating of O-ring lubricant to the index finger and thumb and pull seal sleeve and flange/gland O-ring elements through fingers to inspect for nicks or cuts. Install O-rings in their proper groove locations. This process will prevent an excessive amount of lubricant from being applied to O-ring elements (non-petroleum based grease must be used with EPDM materials).

**Caution:** Do not apply anti-seize or other lubrication to the equipment shaft or shaft sleeve. Keep shaft or shaft sleeves clean and dry. The use of lubricants will cause improper clamping pressure by the seal split clamp/drive collar.

- 4.6 With the seal split clamp/drive collar pointing toward the bearing assembly, slide the complete cartridge over the equipment shaft or shaft sleeve. Push seal flange/gland back toward adapter plate. See Figure 6.

**Important:** Do not hammer or push against rotary face housing or seal sleeve.

### Install Wet Side Cartridge

Figure 6

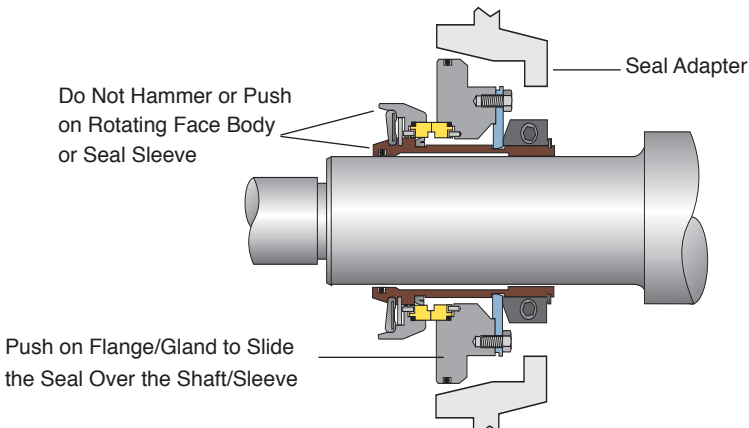

- 4.7 Slide retaining bolts through the rear face of the adapter plate and screw into seal flange/gland. Evenly tighten retaining bolts to pull the seal into the adapter fit. See Figure 7.

**Draw Cartridge into Adapter Using Attachment Bolts**

Figure 7

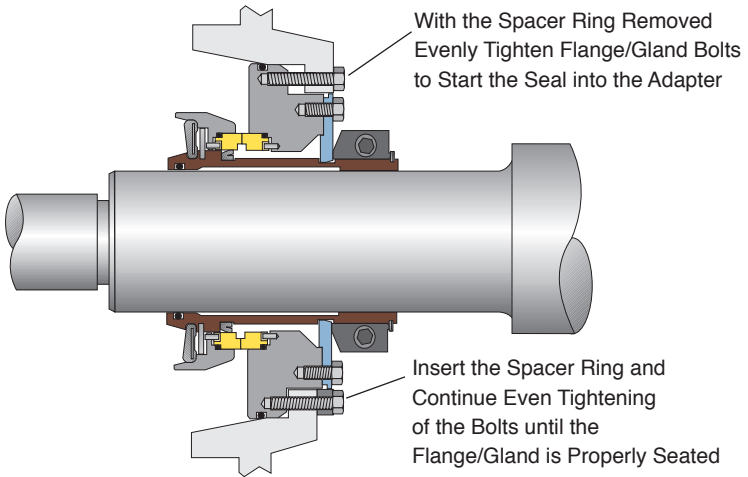

- 4.8 Once the seal flange/gland has started into the adapter fit, remove the retaining bolts and insert the spacer ring. Continue even tightening of the bolts until the seal flange/gland is properly seated. See Figure 7. Some seals do not require the use of the spacer rings; consult job drawing.
- 4.9 If seal is directly mounted on shaft and not on the pump sleeve install impeller spacer hook sleeve (possibly modified), impeller, and suction cover.
- 4.10 Make any necessary impeller adjustments.

**Important:** Loosen bearing assembly and drive belts only enough to make adjustment. Fully tighten bearing assembly bolts after adjustment.

**Torque Value Chart N-m (ft-lb)**

Figure 8

| Fastener Size | Split Clamp/<br>Drive Cap<br>Screws | Group 4-5 Taper<br>Ring Clamp/<br>Drive Cap Screws | Drive Collar<br>Set Screws |                      |
|---------------|-------------------------------------|--|----------------------------|----------------------|
|               | Alloy<br>Steel                      | Alloy<br>Steel                                     | Stainless<br>Steel         | Alloy<br>Steel       |
| 5/16"         | 33 - 35<br>(24 - 26)                | 27 - 30<br>(20 - 22)                               | 14 - 16<br>(10 - 12)       | 18 - 20<br>(13 - 15) |
| 3/8"          | 54 - 61<br>(40 - 45)                | 33 - 37<br>(24 - 27)                               | 20 - 23<br>(15 - 17)       | 30 - 34<br>(22 - 25) |
| 1/2"          | 122 - 136<br>(90 - 100)             | -  | 43 - 49<br>(32 - 36)       | 68 - 75<br>(50 - 55) |

- 4.11 For installations with a 2 piece seal split clamp/drive collar; align the seal clamp/drive collar split lines and alignment key with the seal sleeve slots. This will ensure maximum clamping force. See Figure 14.
- 4.12 Evenly tighten the split clamp/drive collar SHCS (group 1-3 standard), the 3 piece tapered ring SHCS (group 4-5 standard), or the cup point drive set screws (special use with non-hardened shaft or shaft sleeve) to the proper torque values. See Figure 8.
- 4.13 Remove centering/setting plate locking bolts. With a screwdriver, pry centering/setting plates clear of seal flange/gland. Turn centering/setting plates over and swing outward and secure with locking bolts. Keep centering/setting plates with seal at all times. See Figure 9.

## Remove Centering/Setting Plates Prior to Operation

Figure 9

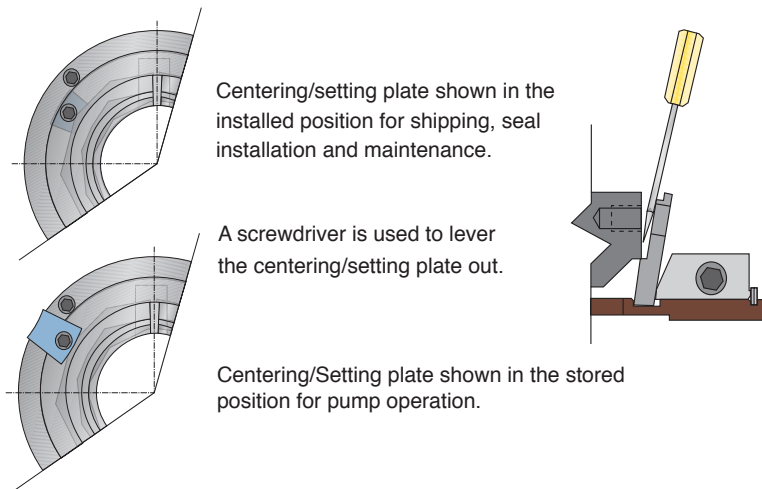

**Note:** With motor coupling disconnected (or drive belts loosened) check equipment for free shaft rotation by manually turning by hand 1-2 revolutions. This is also a good time to check for the proper motor rotation when electrical wires are being connected. If hard rubs occur or for any subsequent impeller or bearing adjustments, reverse steps 4.13, 4.12, 4.11, make adjustments, and then repeat steps 4.11, 4.12, and 4.13. Motor coupling can be reconnected (or drive belts tightened).

Seal installation is complete. Skip forward to section 6 for any optional features of your seal.

## 5 Dry (bearing side) Cartridge Installation

This section describes the installation of the seal cartridge from the dry or bearing side of the equipment case. This type of cartridge is commonly used on ANSI or back pull out bearing equipment designs. If your cartridge is designed to install from the wet or impeller side of the equipment case, consult section 4.

- 5.1 Apply a light coating of O-ring lubricant to the index finger and thumb and pull seal sleeve and flange/gland O-ring element through fingers to inspect for nicks or cuts. Install O-rings in their proper groove locations. This process will help prevent an excessive amount of lubricant from being applied to the O-ring elements (non-petroleum based grease must be used with EPDM materials).

**Caution:** Do not apply anti-seize or other lubrication to the equipment shaft or shaft sleeve. Keep shaft or shaft sleeves clean and dry. The use of lubricants will cause improper clamping pressure by the seal split clamp/drive collar.

- 5.2 With the seal split clamp/drive collar pointing toward the bearing assembly, slide the complete cartridge over the equipment shaft or shaft sleeve. Push seal flange/gland back toward bearing housing. See Figure 10.

**Important:** Do not hammer or push against rotary face housing or seal sleeve.

## Install Dry Side Cartridge

Figure 10

Push on Flange/Gland to Slide the Seal Over the Shaft/Sleeve

Do Not Hammer or Push on Rotating Face Body or Seal Sleeve

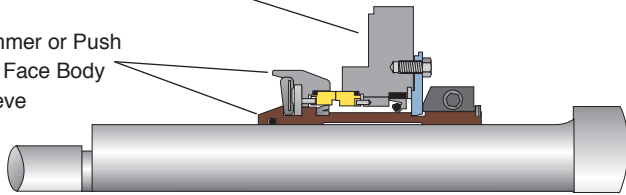

- 5.3 Bolt seal adapter plate to equipment casing/pedestal (hand tighten only).
- 5.4 Locate the seal fit of the adapter to the shaft by use of a dial indicator or centering jig. The equipment shaft must be concentric to the seal adapter bore to within 0.25 mm (0.010 inch) FIM (TIR). See Figure 11. Seal life can vary with improper alignment; poor shaft alignment will yield poor seal life.

## Center Adapter Plate to Shaft

Figure 11

Adapter to be Concentric with Shaft within 0.25 mm (0.010 inch) FIM (TIR)

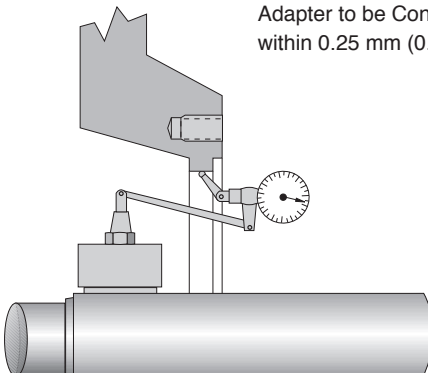



- 5.5 For adapters provided with a centering jig, simply insert the centering jig into the adapter and tighten adapter bolts, alternately adjusting the cover location until the centering jig can be removed by hand.
- 5.6 Dial indicate front face of seal fit on the adapter plate. This fit must be perpendicular to the shaft within 0.25 mm (0.010 inch) FIM (TIR). See Figure 12. If surface is out of tolerance, correct by machining the faces of the locating fits. Be sure to have all fits clean of dirt, rust and/or paint.

**Adapter Plate Mounting Surface Perpendicular to Shaft** Figure 12

---

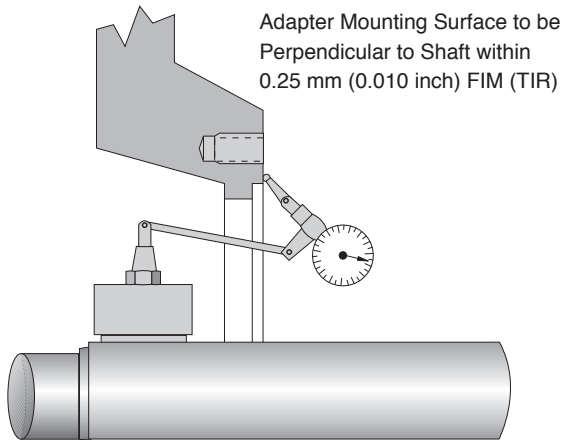

- 5.7 If seal is directly mounted on shaft and not on the equipment sleeve, install impeller spacer hook sleeve (possibly modified) and impeller.
- 5.8 Slide seal flange/gland towards adapter to engage into the locating bore of the adapter plate. Insert retaining bolts through flange/gland holes and screw into front face of the adapter plate. Evenly tighten retaining bolts to pull the seal up to the adapter fit. See Figure 13.

**Bolt Cartridge to Adapter Plate Face** Figure 13

---

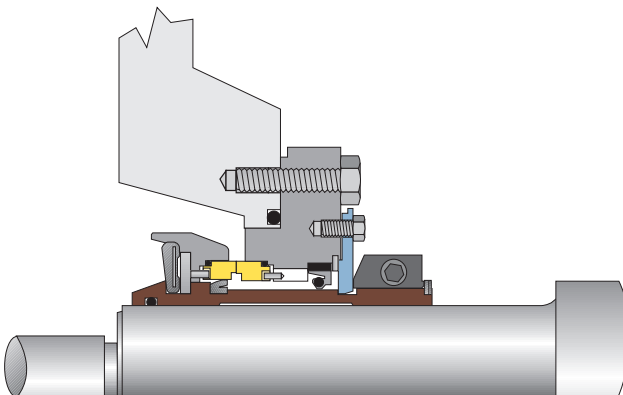

5.9 Install bearing assembly into equipment case. Make any necessary impeller adjustments.

**Important:** Loosen bearing assembly and drive belts only enough to make adjustment. Fully tighten bearing assembly bolts after adjustment.

5.10 For installations with a 2 piece seal split clamp/drive collar; align the seal clamp/drive collar split lines and alignment key with the seal sleeve slots. This will ensure maximum clamping force. See Figure 14.

5.11 Evenly tighten the seal split clamp/drive collar SHCS (group 1-3 standard), the 3 piece tapered ring SHCS (group 4-5 standard), or the cup point drive set screws (special use with non-hardened shaft or shaft sleeve) to the proper torque values listed. See figure 8.

5.12 Remove centering/setting plate locking bolts. With a screwdriver, pry centering/setting plates clear of seal flange/gland. Turn centering/setting plates over and swing outward and secure with locking bolts. Keep centering/setting plates with seal at all times. See Figure 9.

**Note:** With motor coupling disconnected (or drive belts loosened) check equipment for free shaft rotation by manually turning by hand 1-2 revolutions. This is also a good time to check for the proper motor rotation when electrical wires are being connected. If hard rubs occur or for any subsequent impeller or bearing adjustments, reverse steps 5.12, 5.11, 5.10, make adjustments, and then repeat steps 5.10, 5.11, and 5.12. Motor coupling can be reconnected (or drive belts tightened).

## 6 Seals Fitted with Quench and Lip Seal Option

---

6.1 Connect clean, low pressure water to quench inlet. See Figure 14.

### Correct Flange Orientation for Quench Port Connections Figure 14

---

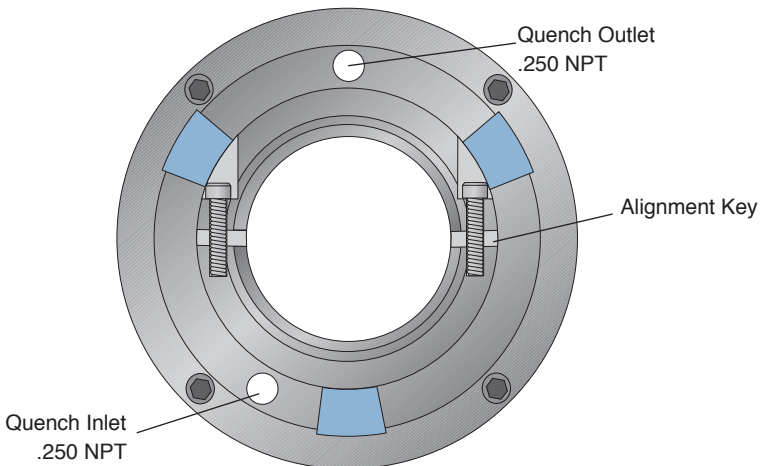

6.2 Quench out should be connected to plant drain.

6.3 Quench water must flow at all times when pump is in operation.

**Note:** Water flow must be regulated to 0.016 - 0.032 liter/sec at 35 kPa maximum (0.25 - 0.50 gpm at 5 psi maximum).

## 7 Normal Operation Procedures

---

The SLC relies on the product pumpage for seal face lubrication since it is typically operated without external flush water.

### 7.1 Equipment Start Up

The equipment cavity must be completely full of liquid before start up.

- Open the discharge washout/bleed valve to release any air that may be trapped in the piping. Close the valve after a steady stream of liquid flows from it. If little or no liquid appears, do not start equipment. This means that part of the piping system is blocking off with solidified product.
- Open suction valve.
- Partially open the discharge valve to ensure that water hammer or cavitation does not occur at start up.
- After start up, slowly open the discharge valve. This will keep a false head on the equipment until the lines completely fill.

### 7.2 Normal Operation

Never allow equipment to run dry during operation, as this will certainly result in premature seal failure.

- Do not allow equipment to cavitate, as this will shorten seal life.
- Do not induce water hammer in the pipeline, as this can place undo strain on the seal components.
- Do not allow the seal chamber pressure to drop below 5 psi while equipment is in operation as this may prevent lubrication from reaching the seal faces.

### 7.3 Equipment Shut Down

All products that will solidify in lines or equipment when idle should be purged from the system.

- Stop the equipment.
- Close the discharge valve.
- Close the suction valve.
- Open the discharge washout/bleed valve. Close the valve after a steady stream of clear liquid flows from it.

For special problems encountered during installation, contact your nearest Flowserve Sales and Service Representative or Authorized Distributor.



TO REORDER REFER TO  
B/M # \_\_\_\_\_  
F.O. \_\_\_\_\_

## 8 Repair

This product is a precision sealing device. The design and dimension tolerances are critical to seal performance. Only parts supplied by Flowserve should be used to repair a seal. To order replacement parts, refer to the part code and B/M number. A spare backup seal should be stocked to reduce repair time.

When seals are returned to Flowserve for repair, **decontaminate the seal assembly** and include an order marked **"Repair or Replace."** **A signed certificate of decontamination must be attached. A Material Safety Data Sheet (MSDS) must be enclosed** for any product that came in contact with the seal. The seal assembly will be inspected and, if repairable, it will be rebuilt, tested, and returned.

FIS125eng REV 09/2018 Printed in USA

**To find your local Flowserve representative**  
and find out more about Flowserve Corporation,  
visit [www.flowserve.com](http://www.flowserve.com)

Flowserve Corporation has established industry leadership in the design and manufacture of its products. When properly selected, this Flowserve product is designed to perform its intended function safely during its useful life. However, the purchaser or user of Flowserve products should be aware that Flowserve products might be used in numerous applications under a wide variety of industrial service conditions. Although Flowserve can provide general guidelines, it cannot provide specific data and warnings for all possible applications. The purchaser/user must therefore assume the ultimate responsibility for the proper sizing and selection, installation, operation, and maintenance of Flowserve products. The purchaser/user should read and understand the Installation Instructions included with the product, and train its employees and contractors in the safe use of Flowserve products in connection with the specific application.

While the information and specifications contained in this literature are believed to be accurate, they are supplied for informative purposes only and should not be considered certified or as a guarantee of satisfactory results by reliance thereon. Nothing contained herein is to be construed as a warranty or guarantee, express or implied, regarding any matter with respect to this product. Because Flowserve is continually improving and upgrading its product design, the specifications, dimensions and information contained herein are subject to change without notice. Should any question arise concerning these provisions, the purchaser/user should contact Flowserve Corporation at any one of its worldwide operations or offices.

© Copyright 2013 Flowserve Corporation

### USA and Canada

Kalamazoo, Michigan USA  
Telephone: 1 269 381 2650  
Telefax: 1 269 382 8726

### Europe, Middle East, Africa

Etten-Leur, the Netherlands  
Telephone: 31 765 028 200  
Telefax: 31 765 028 487

### Asia Pacific

Singapore  
Telephone: 65 6544 6800  
Telefax: 65 6214 0541

### Latin America

Mexico City  
Telephone: 52 55 5567 7170  
Telefax: 52 55 5567 4224