



USER INSTRUCTIONS

Edward Valves

Edward Forged Steel Valves, Bolted and Screwed Bonnet Types

FCD EVENIM2001-04-AQ – 10/15 (Replaces V-376 R3)

*Installation
Operation
Maintenance*



Contents

Typical Valves Designs	3
Introduction	3
Seat and Set Finishing	4
Disks and Disk Tack Welds	5
Backseat and Packings	6
Gland Bolts	7
Reassembly	8
General Information	9

Typical Valve Designs

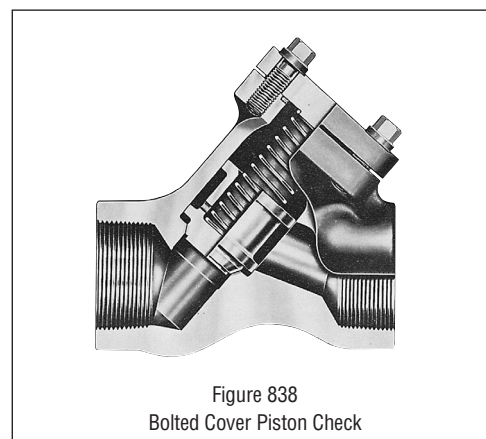
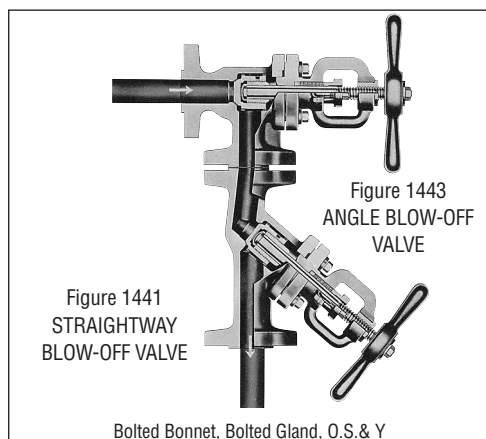
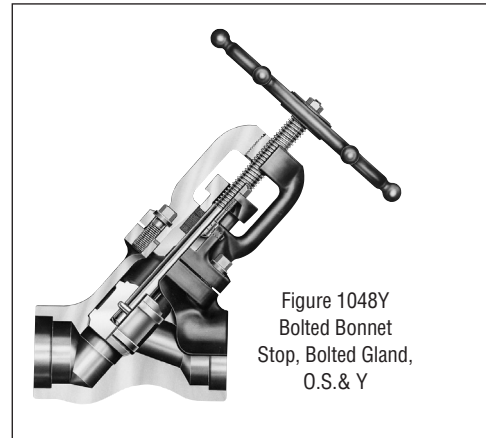
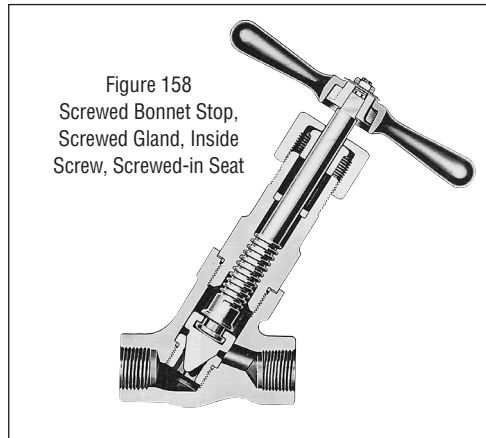

Introduction

This manual is provided to help you service your Flowserve-Edward Forged Steel valves. Before disassembling any valve, we recommend that you check the valve identification plate and note size, figure number and pressure class, so that you can identify it in the appropriate Flowserve-Edward Valve catalog. This catalog will show typical cross sections to help identify the various parts.

Tools

Most Flowserve-Edward Forged Steel valves may be readily disassembled with ordinary hand tools. For the removal of screwed-in valve seats, a special wrench may be necessary.

Disassembly

Confirm the valve is not under pressure when disassembling valves.

EDWARD VALVES, INC RALEIGH, NC 27603	BOLTED BONNET SIZE 1.00
3600 CWP 1830 PSI AT 800F MAX	FIG 1049Y B/M 00707421 0000000 BODY A105 BONNET A105 STEM CR-13 DISK 615 SEAT INT HF DATE OF MFR: 07/1997
PACKING TORQUE: FT-LBS INITIAL PRELOAD 7 THEN RELOAD AT 3	
IMPORTANT: SEE EDWARD VALVE MANUAL EV-376 FOR MAINTENANCE AND ASSEMBLY INSTRUCTIONS. STEM THREADS MUST BE KEPT LUBED WITH EP-2.	

Typical Identification Plates

Bolted Bonnet

In bolted bonnet/ cover style valves, cap screws should be removed (see page 3 and below). The bonnet assembly or cover can then be removed and the interior of the valve exposed.



Figure 238 - Bolted Cover Strainer

Screwed Bonnet

Small valves of the screwed bonnet type are disassembled by unscrewing the bonnet.



Screwed Bonnet Construction

Seats and Seat Finishing

Seats

Flowserve-Edward valve seats are of two types: screwed-in (with “O”Ring Seal) or integral with the valve body.



Screwed-in seats can best be repaired, if more than lightly damaged, by removal from the valve. If screwed-in seats are badly damaged, it may be more economical to replace them with new seats; however, if they are repairable, they may be remachined on a lathe. The part should be accurately centered in the lathe before machining. Seats can be cut with highspeed tool bits. Stellite-faced seats must be machined with tungsten-carbide tools or by grinding. In replacing a screwed-in seat in the valve body, care should be taken that the face on the body against

which the seat shoulder rests is clean and true to provide a tight seal. New “O”Rings should always be used. Surfaces should be blued and checked for contact all the way around when replacing a seat. Care should be taken that reworking does not throw the sealing face between body and seat out of line with the seat threads.



Integral Seat

Integral valve seating surfaces cannot be removed for repair. Once the valve has been disassembled and thoroughly cleaned, determine the best procedure based on the extent of damage. Lightly damaged seats may simply be repaired by lapping with the valve disk assembly.

Heavier damage may require the use of special lapping tools or removal of the valve body from the line for remachining. These valves should then be finish-lapped using the valve disk assembly (see sketch on page 5). Seat refinishing tools are also available for integral Stellite seat valves. Consult your local Flowserve representative.

Complete instructions for the repair and finishing of integral Stellite valve seats are contained in “Univalve Operation and Maintenance Manual” FCD EVENIM2000 (Bulletin V-370).

NOTE: Refer to Appendix for list of Seat Refinishing Tools.

Seat Finishing

After properly installing seats in valve bodies or reworking integral seat valves, the seat and disk should be lapped together. To preclude galling, caution should be taken not to apply too much pressure in lapping seats and disks. Lapping should be done with a light load, lifting the disk frequently to a new position and cleaning the lapping faces as required. See sketch on page 5.

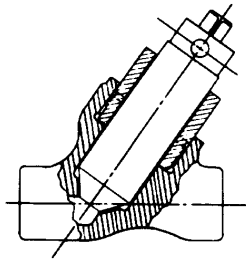

Lapping with Lap or Abrasive Disk

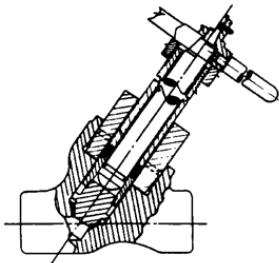

Lapping with Valve Disk Assembly

The effectiveness of valve seat lapping can best be judged by blueing the disk and rotating it lightly in the seat. A full contact should be obtained around the circumference of the seat. A valve that shows this full contact should be pressure tight after assembly when proper stem load is applied.

Disks and Disk Tack Welds

Disks

In all Flowserve-Edward valves, disks are designed to swivel on the valve stem. They are held in place by either a “T”-slot connection, a disk nut, or Stellite wire.



T-slot Construction



Disk Nut Construction



Stellite Wire Construction

Stop-Check valve disks are not attached to the stem and respond to the fluid flow in the same manner as check valve disks (see below). The disk seating face can be repaired in a similar manner to that described for seats.

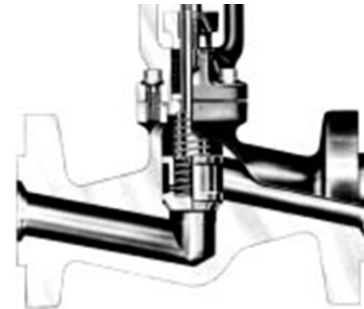

Figure 846: Typical Stop-Check Valve with Body-Guided Disk

Valve stems are normally provided with a radius at the disk contact to give center loading. If foreign material gets between this spherical surface and the disk, or if galling occurs, it may not be possible to close the valve tightly. In a leaking valve this contact should be checked, if possible, to be sure it is in proper condition.

Disk Tack Welds

In body-guided valve disks with disk nuts, the disk nut is secured to the disk by a small weld through the side of the disk, fusing the disk nut threads and preventing loosening of the disk assembly in service. Such disks can easily be disassembled if required by drilling out the fused material at the bottom of the small hole in the disk. The disk nut can then be unscrewed for servicing. Care must be taken not to drill through the disk nut wall or the stem may be damaged. When repairs are complete, the parts can be reassembled with care being taken to screw the disk nut down until only a few thousandths of an inch in end play remain in the assembly. The parts can then be lock-welded again by depositing weld metal at the bottom of the small hole in the disk.

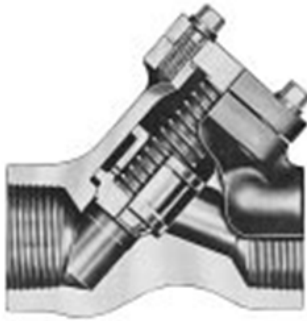

Figure 838: Bolted Cover Piston Check

Valves may be body-guided by rings on the disk or in the case of “T”-slot disks by the disk outside diameter. A similar body guiding arrangement may be found in check valves. Some ball check valves are guided by an extension of the cover (see Figure 160). The wear on sliding surfaces inside valves should be considered and the surfaces checked to be sure wear has not resulted in ridges in the guide bore, which might impair disk movement. Guiding in check valves is particularly critical.

The guides must be close enough to bring the disk accurately down into the seat to make a tight joint.



Figure 160: Screwed-Cover, Cover-guided Ball Check, Screwed-in Set

Foreign material in the flow medium may wedge between guiding surfaces with the possibility of making the disk stick. It is recommended that piston check valves be used where the fluids are clean and where tight seating is important. In smaller sizes, it is recommended that ball type check valves be used where the problem of sticking open is of serious consideration. Valves sized too large for flow condition will sometimes have excessive wear, chatter and noise.

Backseat and Packings

Backseat

Flowserve-Edward stop valves have a backseat integral with the bonnet. The seating face on the bonnet is generally a bevel and the seating surface on the disk, disk nut, or stem is provided with either a radius or a bevel. Care must be taken of sealing surfaces on both the bonnet and the radius, which seals against it to obtain a tight backseat.



Integral Backseat Construction

Packings

Flowserve-Edward valves are packed with all-purpose packing sets. This is a combination of packing using braided rings at the top and bottom of the packing chamber and flexible graphite packing in the center section. Packing glands should be tightened down enough to prevent leakage but not enough to develop excessive operating torque.

When the gland has advanced approximately half way into the packing chamber, it is recommended that additional packing rings be added. To obtain best results, the stem should be thoroughly cleaned.

Replacement packing should be the same as that originally furnished. Flowserve-Edward valve packings are inhibited to prevent stem pitting in service.

We recommend packing be purchased from Flowserve-Raleigh to assure packing with the proper density and corrosion inhibitors is always used.

IMPORTANT!

- Long service life from modern graphitic packing requires that adequate preloads be applied when repacking.
- All parts should be clean and not scored or pitted, especially the stem.
- The stem, disk and bonnet should be in the valve prior to installing the new packing.
- Position split packing with the ends of adjacent rings rotated 90°.
- Standard packing

Top Ring	Braided Ring
Center Ring	Flexible Graphite Ring
Bottom Ring	Same as top
- Clean and lubricate the gland bolts.
- Tamp the packing down by hand using the gland.
- **IMPORTANT!** Apply the recommended torque to the gland nuts evenly without cocking the gland. See table.
- Tighten nuts to the initial values shown, then loosen and retighten to the final range.
- Stroke the stem and then recheck the torque on the gland bolts.

Gland Bolts

Packing Chamber Schematic

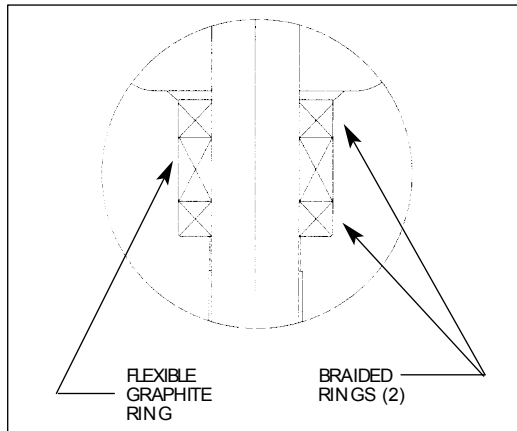

Valves of the Figure 158 , 5158 , 9158 (see pg. 3) type have a packing nut with threads that should be kept well lubricated to prevent corrosion and eliminate packing adjustment difficulties.

Gland Bolts

The removal of glands is accomplished by removing the nuts. Swing bolts can be removed by also driving out the pin.

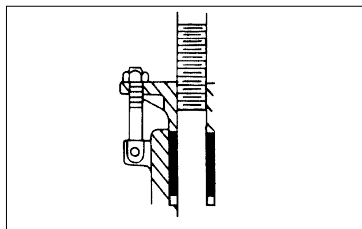

Swing Type

Packing Gland Torque

FIGURE NUMBERS		VALVE SIZE				
		1/4, 3/8 1/2	3/4	1	1-1/4 1-1/2	2
158 5158, 9158	final	125-130 FT-LB	140-145 FT-LB	265-270 FT-LB	280-285 FT-LB	435-440 FT-LB
828, 829 847, 848 849, 868, 869	initial	21	40	62	153	210
	final	8-18	15-25	24-34	59-69	81-91
1029, 1047 1048, 1068 1069	initial	21	40	62	153	210
	final	15-25	28-38	43-53	106-116	145-155
1441, 1443 1641, 1643	initial				250	287
	final				71-81	82-92
1028 1046	initial	40	62	62	153	210
	final	28-38	43-53	43-53	106-116	145-155

ALL TORQUES ARE GIVEN IN INCH-POUNDS EXCEPT WHERE NOTED

Yoke Bushing

The yoke bushings of small Flowserve-Edward valves are threaded to the yoke. Bushings are subject to wear in services where large amounts of grit accumulate on the valve threads. Lubrication aids easy operation of valves and reduces wear of yoke bushings.



Reassembly

Valves of the screwed bonnet/ cover type construction are sealed at the bonnet by flat, soft metal gaskets and “O” Rings. Screwed-in seats are also sealed by “O” Rings. Such seals require smooth clean surfaces on body, bonnet or seat. Bolted bonnet valves, such as Figure 848 type, are sealed with spiral-wound gaskets. In all valves, new gaskets (and “O” Rings) are recommended for reassembly. Bonnet gaskets (and “O” Rings) are inexpensive and available out of factory stock.

Valves with screwed bonnet/ cover joints require the bonnet threads to be well lubricated and tightened to develop sufficient gasket compression.

Bolted Bonnet/Cover Torques

A torque wrench should be used for tightening the bonnet, which is used to preload the spiral-wound gaskets.

The following procedure is recommended:

1. Guard against leakage by having these capscrews tight at all times.
2. Capscrews should be tightened to the torque shown below.

Bolt diameter, Inches									
3/8	7/16	1/2	9/16	5/8	3/4	7/8	1	1-1/8	1-1/4
Torque, Ft. Lbs.									
18	30	45	68	90	150	240	370	585	750

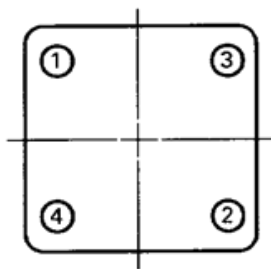

Step #1

Snug to approximately 10% of full recommended torque.
Sequence: 1-2-3

Step #2

Torque to approximately 75% of full recommended torque.
Sequence: 4-3-2

Step #3

Torque to full recommended torque. Sequence: 1-2-3-4

NOTE: The steps for tightening cover capscrews is for the purpose of pulling the cover down evenly. If this objective can be achieved without following this suggested method precisely, then some variation from this method is permissible.

Seat Ring & Bonnet/Cover Torques

Valve Size	Figure Number	Seat Ring Torque	Bonnet/ Cover Torque
1/4, 3/8, 1/2	158,160	75	40
3/4	158,160	100-120	60
1	158,160	240-260	125
1-1/4, 1-1/2	158,160	320-340	150
2	158,160, 5158, 5160, 9160	400-420	300

Welding Flowserve-Edward Valves into Piping Welding is outside the scope of this manual, but Flowserve recommends you consult the appropriate welding procedure in ASME/ ANSI B31, or whatever other codes apply to your system. When welding Flowserve-Edward valves into piping, make sure there is no foreign material on the seat joint, then close the valve tightly to avoid distorting the seats.

After welding, open the valve and flush the line to clean out all foreign matter.

Lubrication

In order to obtain full service life, valves require periodic lubrication of the stem threads. Exposed threads should be wiped clean of old grease and accumulated dirt and fresh lubricant applied. This is most effectively done with the valve in the closed position.

For valves that see frequent operation, such as motor-actuated, the lubricant should be replenished every three months. If extreme service conditions dictate, a more frequent relube schedule is recommended. Motor-actuated valves have a lubricant fitting at the yoke flange.

The recommended lubricant for all stem threads, bonnet, packing nut and bolt threads is Rykon EP #2, manufactured by the American Oil Company. This is an extreme pressure, extreme temperature lubricant of high quality. For valves that are operated infrequently, relubrication should be at least once a year.

General Information

WARNING: Flowserve-Edward valves are not provided with a pressure relief device. A pressure relief device must be provided elsewhere in the piping system to prevent the piping system pressure from exceeding the maximum rated pressure of the valve.

Piping Support

Piping should be supported sufficiently to preclude excessive end loads on the valve.

VALVE INSTALLATION GUIDELINES

Except as noted below, Flowserve-Edward stop valves and stop-check or check valves with springs can be installed in any position. Installed positions with the valve cover or bonnet below horizontal, where dirt and scale can accumulate in the valve neck, should be avoided.

For optimum performance, the orientation limits shown in Figures 1 and 2 should be observed even for spring-loaded check valves.

The orientation limits shown in Figures 1 and 2 must not be exceeded for Flowserve-Edward stop-check valves and check valves without springs. The limitations given for line inclination and bonnet roll angle should not be combined.

All check and stop-check valves should be installed with 10 or more diameters of straight pipe upstream of the valve to minimize flow disturbances. For additional information, refer to the "Technical" section of the Flowserve-Edward Valves Catalog, Publication FCD EVENCT0001.

Seat and Disk joint leaks

A leak existing between the seat and disk of a closed valve might be indicated by one of the following: a definite pressure loss in the high pressure side of the valve; continued flow through an inspection drain on the low pressure side; or, in hot water or steam lines, a downstream pipe that remains hot beyond the usual length of time and conductivity range.

Such a leak may be the result of closing on dirt, scale or other foreign matter in the line. It may also develop because of the operator's failure to close the valve tightly. An increased velocity is imparted to a flow forced through a very small opening. This increased velocity subsequently gives rise to the "cutting" of both disk and seat, particularly by particles of line scale or rust in suspension or normal solids in solution. In spite of the fact that the hard-surfaced material on the seat and disk is corrosion and erosion-resistant, grooves, pit marks, or other surface irregularities may be formed on the seat and disk joint surfaces when the disk is closed against a foreign body on the seat. This sometimes occurs during the initial start-up of a piping system.

Leakage of steam through a valve that is badly steam-cut has a whistling or sonorous sound. If the valve is only slightly steam-cut, however, leakage is identified by subdued gurgling or weak popping sounds. These sounds can be heard through a stethoscope or by placing one end of a stick against the valve body while holding the other end between the teeth, with hands over the ears.

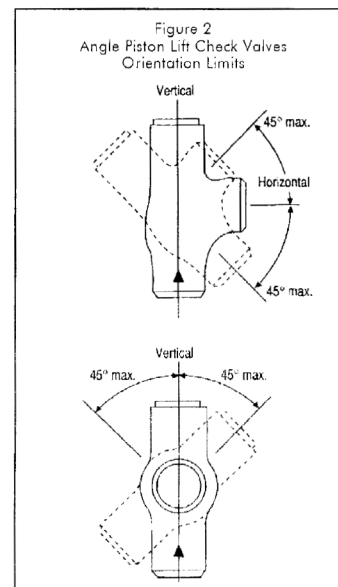
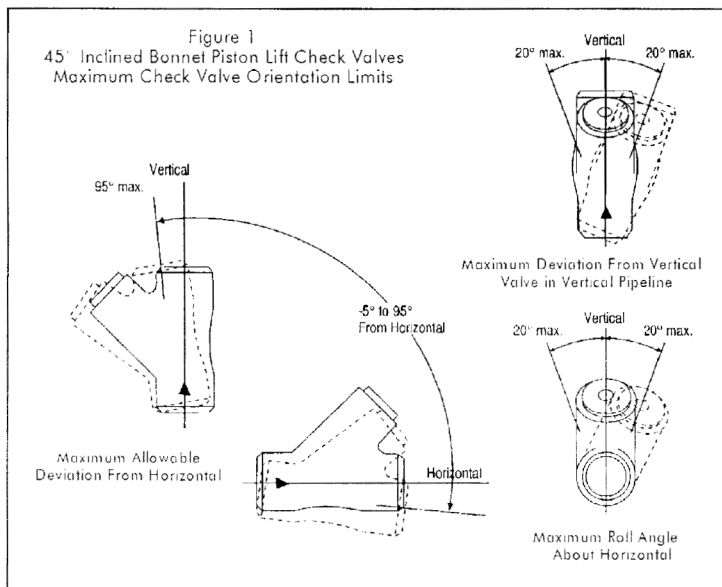

Notes On Valve Operation

Valves equipped with electric motor actuators have special tags attached, which indicate the correct torque switch setting for the valve. Exceeding these torque switch settings can cause damage to the valve. Never use an electric motor actuator to backseat a valve. This can result in damage to the valve stem and bonnet backseat.

Notes On Valve Maintenance

When replacing the bonnet gaskets, follow the torque requirements on page 9 closely. Failure to torque the gasket properly will result in gasket failure. When replacing the valve stem packing, never machine the packing chamber oversize. This will result in blowout of the packing.

How To Order Parts

During normal working hours, call 800-225-6989 or 919-832-0525. To assure the correct parts for your Flowserve-Edward valve, include the valve size, the figure number, including any prefix and/or suffixes and, if available, the B/M number. All nuclear valves require the B/M number to properly identify your valve.

This information is located on the valve nameplate. The nameplate is attached to a yoke leg via a cable. If the nameplate is inaccessible, you can use your Flowserve-Edward sales drawing; please include the drawing number as well.

SERVICE

If you have any further questions on valve repair or part replacement, your Flowserve representative will be happy to assist you. Flowserve-Edward catalogs are available on request.

Flowserve Corporation has established industry leadership in the design and manufacture of its products. When properly selected, this Flowserve product is designed to perform its intended function safely during its useful life.

However, the purchaser or user of Flowserve products should be aware that Flowserve products might be used in numerous applications under a wide variety of industrial service conditions. Although Flowserve can (and often does) provide general guidelines, it cannot provide specific data and warnings for all possible applications. The purchaser/user must therefore assume the ultimate responsibility for the proper sizing and selection, installation, operation, and maintenance of Flowserve products. The purchaser/user should read and understand the Installation Operation Maintenance (IOM) instructions included with the product, and train its employees and contractors in the safe use of Flowserve products in connection with the specific application.

While the information and specifications contained in this literature are believed to be accurate, they are supplied for informative purposes only and should not be considered certified or as a guarantee of satisfactory results by reliance thereon. Nothing contained herein is to be construed as a warranty or guarantee, express or implied, regarding any matter with respect to this product. Because Flowserve is continually improving and upgrading its product design, the specifications, dimensions and information contained herein are subject to change without notice. Should any question arise concerning these provisions, the purchaser/user should contact Flowserve Corporation at any one of its worldwide operations or offices.

Appendix

Seat Refinishing Tools

848 Valves				
Size	Tool Head Assembly	Guide Bushing	Replacement Cutters	No. Of Cutters on Head Assembly
0.5	876111	169077	Not Repl.	3
0.75	876112	169078	Not Repl.	3
1	876113	169079	876703	3
1¼ - 1½	876115	169080	876703	5
2	876115	169081	876703	5

1048 Valves				
Size	Tool Head Assembly	Guide Bushing	Replacement Cutters	No. Of Cutters on Head Assembly
0.5	None Available	None Available	N/A	N/A
0.75	876111	169078	Not Repl.	3
1	876112	169082	Not Repl.	3
1¼ - 1½	876114	169083	876703	5
2	876115	169084	876703	5

Complete instructions for the repair and finishing of integral Stellite valve seats using the above seat refinishing tools are contained in Service Manual for Edward Univalves FCD EVENIM2000 (Bulletin V-370).

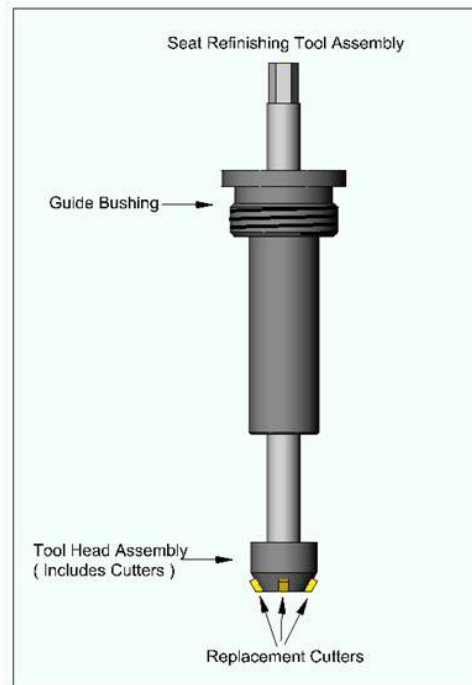



Flowserve Flow Control Division
Edward Valves
1900 South Saunders Street
Raleigh, NC 27603
USA

FCD EVENIM2001-04-AQ 10/15 Printed in USA. (Replaces V-376 R2)

To find your local Flowserve representative
or for more information about Flowserve Corporation, visit
www.flowserve.com.

Flowserve Corporation has established industry leadership in the design and manufacture of its products. When properly selected, this Flowserve product is designed to perform its intended function safely during its useful life. However, the purchaser or user of Flowserve products should be aware that Flowserve products might be used in numerous applications under a wide variety of industrial service conditions. Although Flowserve can (and often does) provide general guidelines, it cannot provide specific data and warnings for all possible applications. The purchaser/user must therefore assume the ultimate responsibility for the proper sizing and selection, installation, operation, and maintenance of Flowserve products. The purchaser/user should read and understand the Installation Operation Maintenance (IOM) instructions included with the product, and train its employees and contractors in the safe use of Flowserve products in connection with the specific application.

While the information and specifications contained in this literature are believed to be accurate, they are supplied for informative purposes only and should not be considered certified or as a guarantee of satisfactory results by reliance thereon. Nothing contained herein is to be construed as a warranty or guarantee, express or implied, regarding any matter with respect to this product. Because Flowserve is continually improving and upgrading its product design, the specifications, dimensions and information contained herein are subject to change without notice. Should any question arise concerning these provisions, the purchaser/user should contact Flowserve Corporation at any one of its worldwide operations or offices.

© 2015 Flowserve Corporation, Irving, Texas, USA. Flowserve is a registered trademark of Flowserve Corporation.