



Concentrated Solar Power

Parabolic Trough • Power Tower



Experience In Motion



A Pump for Every Application Under the Sun

Flowserve is the driving force in the global industrial pump marketplace. From the introduction of the first direct acting steam pump in 1840 to today's most advanced nuclear station design, Flowserve has pioneered virtually every significant advancement in pumping technology for the power generation industry.

Today, Flowserve is extending that leadership to the many forms of alternative energy generation, including concentrated solar power (CSP). Flowserve offers the industry's most comprehensive package of pump products, technical support and services for CSP. From molten salts and heat transfer fluids to condensate extraction cooling water systems, Flowserve has proven pump solutions that are both highly reliable and highly efficient.

No other pump company in the world can boast a product line that includes pumps for every CSP application.

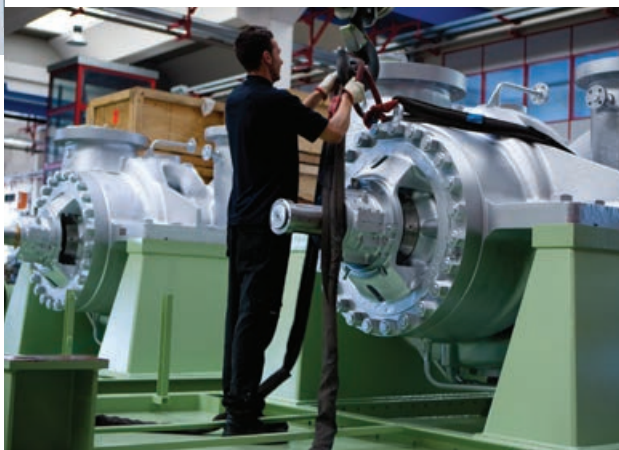

Product Brands of Distinction

- ACEC™ Centrifugal Pumps*
- Aldrich™ Pumps*
- Byron Jackson® Pumps*
- Calder™ Energy Recovery Devices*
- Cameron™ Pumps*
- Durco® Process Pumps*
- Flowserve® Pumps*
- IDP® Pumps*
- INNOMAG® Sealless Pumps*
- Lawrence Pumps®*
- Niigata Worthington™ Pumps*
- Pacific® Pumps*
- Pleuger® Pumps*
- Scienco™ Pumps*
- Sier-Bath® Rotary Pumps*
- TKL™ Pumps*
- United Centrifugal® Pumps*
- Western Land Roller™ Irrigation Pumps*
- Wilson-Snyder® Pumps*
- Worthington® Pumps*
- Worthington Simpson™ Pumps*



Supplier of Choice to the Concentrated Solar Power Industry

With its extensive experience in power generation, unmatched pumping technology and best-in-class technical know-how, Flowserve is the trusted choice for renewable energy generation. No other pump company in the world has the depth and breadth of expertise in the successful application of pre-engineered, engineered, and special purpose pumps and systems for all CSP services.

- High-pressure vertical molten salt pumps
- Heavy-duty, radially split, between bearings heat transfer fluid (HTF) pumps
- Between bearings, radially and axially split, multistage boiler feed water pumps
- Vertical and horizontal circulating water pumps
- Mixed flow and vertical turbine condensate extraction pumps
- Radially split, axially split and overhung auxiliary service pumps

Complete System Responsibility

Flowserve pump, valve and seal divisions work in concert to develop optimally designed and fully integrated process equipment. That means Flowserve provides complete system responsibility so CSP generators can focus on their mission — harnessing the clean energy of the sun.

Committed to the Complete Pump System Life Cycle

For more than two centuries, Flowserve has served industries requiring solutions that add value and reduce costs throughout the life cycle of a pumping system.

- Power generation
- Oil and gas
- Chemical
- Water
- General industry



Flowserve partners with customers to respond to the dynamic business conditions that affect them. Flowserve works with customers to improve efficiency, maximize throughput and control process quality. Whether customer needs involve on-site technical assistance, equipment upgrades or broader project planning with full turnkey responsibility, Flowserve delivers professional, reliable results.

The world's only complete line of pumps for concentrated solar power generation



Parabolic Trough

Parabolic trough CSP stations require a broad range of pumps to handle applications, including high-temperature heat transfer fluids (HTF), superheated feedwater, condensate and cooling water. Flowserve is the only pump manufacturer able to provide a solution for every application in parabolic trough solar power stations.

The most demanding of these pump applications are heat transfer fluid circulation and molten salt heat exchange storage. At temperatures approaching 400°C (750°F), they present difficult hydraulic and sealing challenges. Flowserve has successfully and routinely surmounted these hurdles.

Simplified Parabolic Trough Flow Diagram

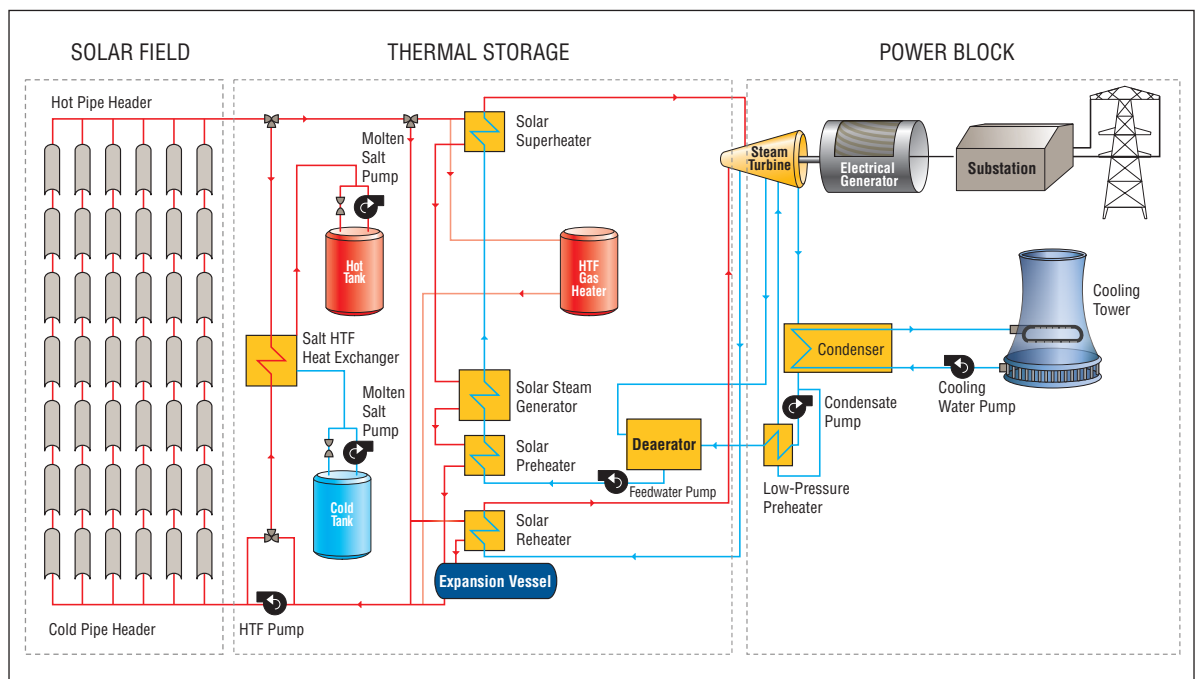



Gemasolar Plant
Property of Torresol Energy © Torresol Energy

Power Tower

Whether using molten salt or superheated water, power tower systems present varied and unique pumping demands. With unmatched product and application expertise, Flowserve provides the best combination of equipment, materials, and ancillary systems for efficient operation and extended reliability in these onerous services.

- Molten salt systems produce harsh operating conditions as temperatures near 600°C (1100°F). Flowserve is the leading supplier of high-pressure vertical pumps for this service.

- Superheated water systems face numerous challenges associated with high pressure and temperature pumping. Whether axially or radially split, single or double case, Flowserve can provide custom-engineered pumps for the harshest applications.
- Flowserve also offers a complete package of power station pumps, including those for conventional turbine-generator main cooling and condensate service, solar pre-warmer feed and auxiliaries.

Simplified Power Tower Flow Diagram

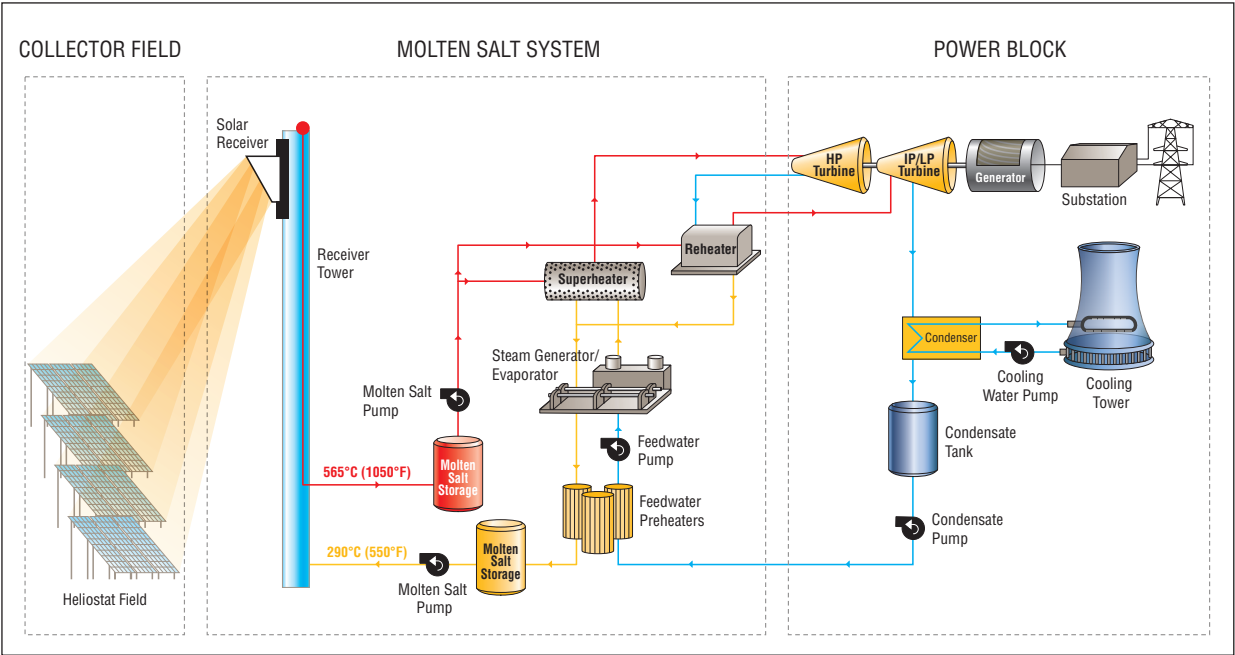

The Flowserve Molten Salt VTP is the industry's leading vertical pump for molten salt circulation.

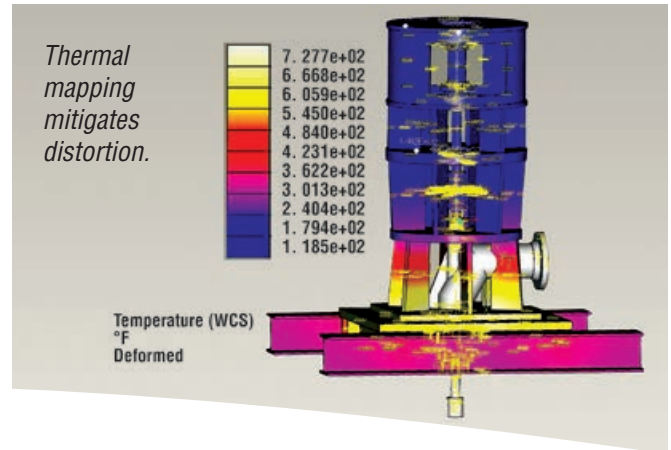

Molten Salt Pumps

A mixture of sodium nitrate (NaNO_3) and potassium nitrate (KNO_3), molten salt possesses high thermal conductivity, allowing temperatures to reach 600°C (1100°F). As a leading provider of molten salt pumps for more than 60 years, Flowserve understands the detrimental effects of heat distortion on a vertical pump. That's why Flowserve engineers utilize advanced thermal mapping software to ensure heat dissipation is adequate and distortion is mitigated.

Vertical Turbine Pumps for Primary Molten Salt Service

Single- or multistage diffuser designs

Operating Parameters

- Flows to $13\,600\text{ m}^3/\text{h}$ (60 000 gpm)
- Heads to 530 m (1740 ft)
- Pressures to 100 bar (1450 psi)
- Temperatures to 600°C (1100°F)
- Settings to 20 m (65 ft)

Vertical Lineshaft and Cantilever Pumps for Auxiliary Molten Salt Services

Operating Parameters

- Flows to $1400\text{ m}^3/\text{h}$ (6160 gpm)
- Heads to 250 m (820 ft)
- Pressures to 25 bar (365 psi)
- Temperatures to 600°C (1100°F)

Key Features and Benefits of the Molten Salt VTP Pump

- Low pump submergence allows for greater energy generation.
- Low NPSHR allows for enhanced suction performance.
- Excellent heat dissipation design prevents distortion at high temperatures.
- Advanced fluid sealing system protects against fluid leakage and reduces heat conduction.
- Materials are engineered to equalize thermal growth and forestall distortion.

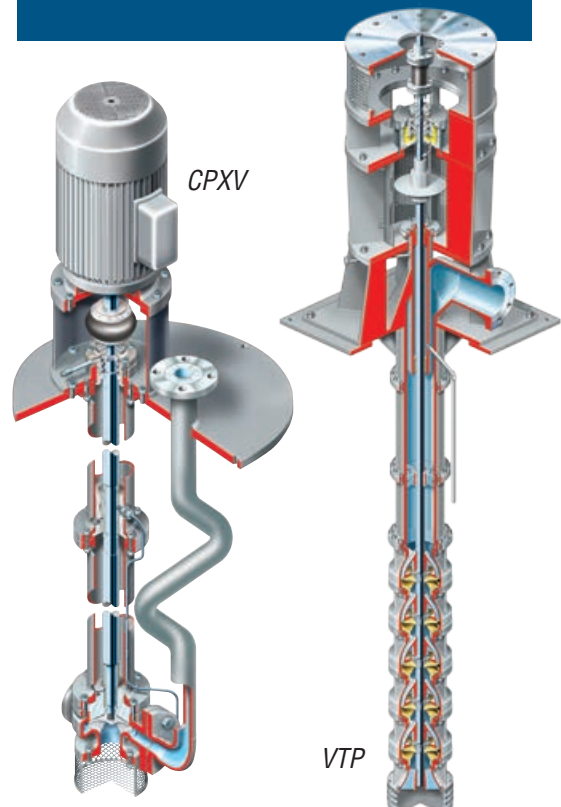



Heat Transfer Fluid Pumps

Regardless of the HTF used, Flowserve pumps can really take the heat.

Radially Split, Double-Suction API Pumps for Primary HTF Circulation

ISO 13709/API 610 (BB2); engineered for reliable, efficient operation at elevated temperatures and pressures

Operating Parameters

- Flows to 4100 m³/h (18 000 gpm)
- Heads to 450 m (1500 ft)
- Pressures to 100 bar (1450 psi)
- Temperatures to 450°C (842°F)

API Process Pumps for Auxiliary Service

Centerline mounted, single-stage, overhung pumps; available for auxiliary HTF services such as secondary recirculation, overflow, makeup and storage

Operating Parameters

- Flows to 2000 m³/h (8800 gpm)
- Heads to 350 m (1100 ft)
- Pressures to 80 bar (1160 psi)
- Temperatures to 450°C (842°F)

Key Features and Benefits of the HDX Pump

- Centerline mounted design ensures proper alignment and minimizes pipe stresses at high temperatures.
- Between bearings design provides outstanding shaft stability for long bearing and seal life.
- Double-suction impeller compensates for low NPSHA.
- Custom-engineered mechanical seal prevents shaft leakage and corrosion.

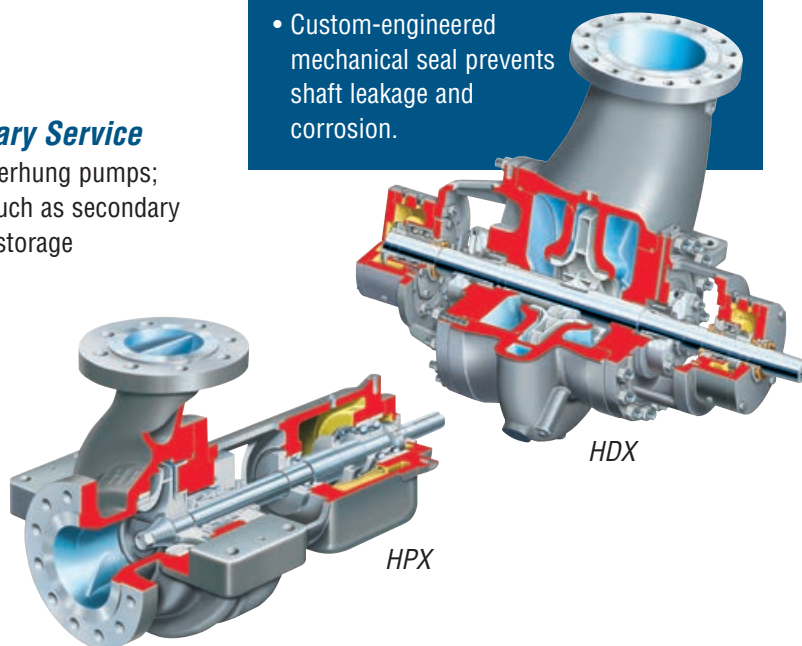

Flowserve has repeatedly proven it builds the highest quality, most reliable boiler feed pumps.

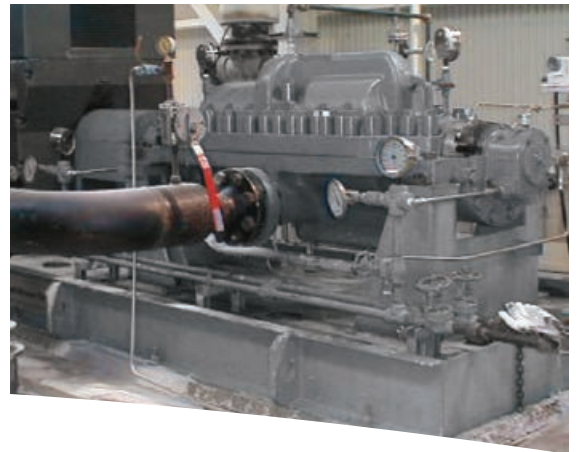

Boiler Feed Water Pumps

Boiler feed pumps are among the most critical pieces of rotating equipment in the steam cycle. Regardless of the type of power plant, Flowserve has repeatedly proven it builds the highest quality, most reliable boiler pumps available. Flowserve has several radially and axially split, multistage, between bearings pump models with single- or double-suction, first-stage impellers to meet application needs.

Multistage, Segmental Ring Diffuser Pumps

Between bearings, radially split designs

Operating Parameters

- Flows to 1160 m³/h (5100 gpm)
- Heads to 2750 m (9000 ft)
- Pressures to 310 bar (4500 psi)
- Temperatures to 205°C (400°F)

Multistage, Horizontal Split Case Volute Pumps

Between bearings, axially split, double volute case, side suction, side discharge

Operating Parameters

- Flows to 2950 m³/h (13 000 gpm)
- Heads to 2130 m (7000 ft)
- Pressures to 275 bar (4000 psi)
- Temperatures to 204°C (400°F)

Key Features and Benefits of the WXH and DMX Feed Pumps

- Centerline mounted design ensures proper alignment and minimizes pipe stresses at high temperatures.
- Between bearings design provides outstanding shaft stability for long bearing and seal life.
- Optional double-suction, first-stage impeller compensates for low NPSHA.
- Mechanical seals with integral pumping ring maintain optimal sealing temperatures.

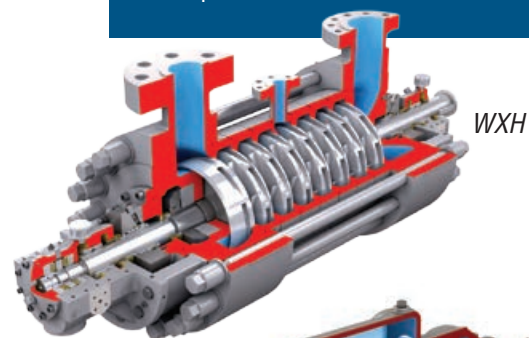

WXH

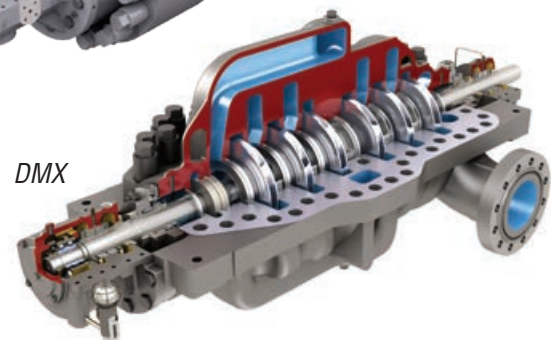

DMX

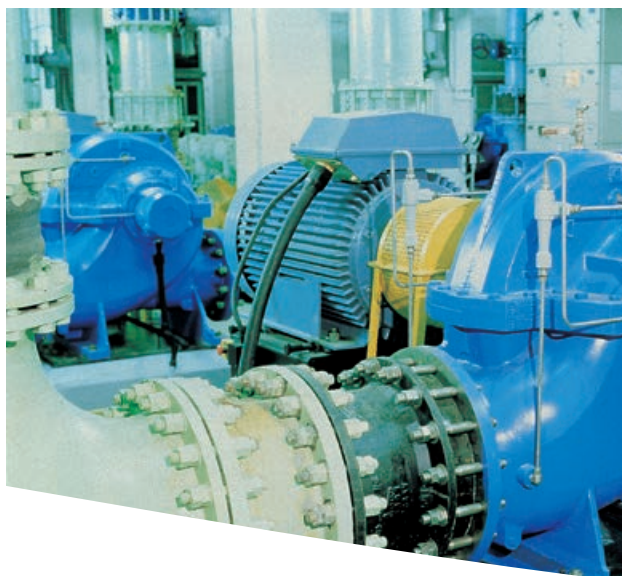

Circulating Water Pumps

Flowserve offers several vertical and horizontal pump models for reliable and extended operation in circulating water service.

Vertical, Wet-Pit Pumps

Mixed flow, pullout and non-pullout designs

Operating Parameters

- Flows to 181 700 m³/h (800 000 gpm)
- Heads to 110 m (350 ft)
- Pressures to 10 bar (150 psi)
- Temperatures to 95°C (200°F)

Vertical Turbine Pumps

Single- and multistage diffuser casing designs

Operating Parameters

- Flows to 13 600 m³/h (60 000 gpm)
- Heads to 700 m (2300 ft)
- Pressures to 100 bar (1450 psi)
- Temperatures to 300°C (570°F)

Horizontal, Between Bearings, Single-Stage Pumps

Heavy-duty, axially split, double volute, double-suction

Operating Parameters

- Flows to 30 000 m³/h (132 000 gpm)
- Heads to 300 m (985 ft)
- Pressures to 40 bar (580 psi)
- Temperatures to 150°C (300°F)

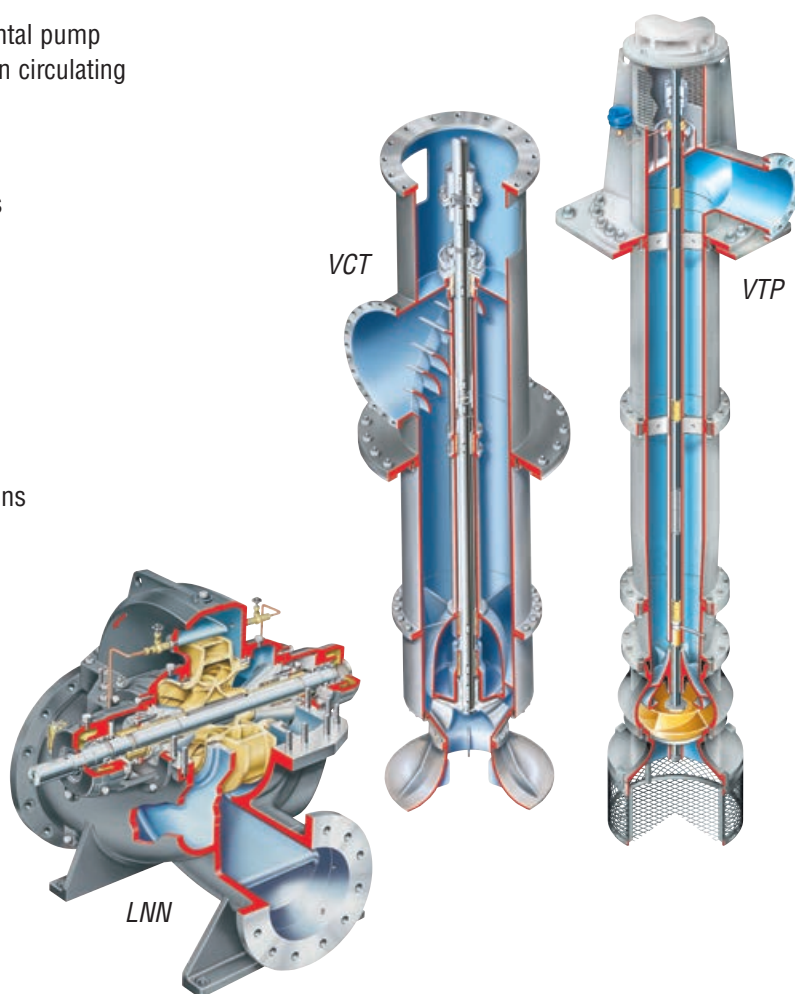

No other pump company has the systems knowledge, hydraulic expertise or application know-how Flowserve possesses.



Condensate Extraction Pumps

Flowserve has a long and proven performance record in condensate extraction. Its versatile line of vertical condensate extraction pumps has unsurpassed hydraulic coverage and a broad range of available options to address system requirements.

Vertical, Multistage, Canned Pumps

Multistage, mixed-flow designs with single- or double-suction, first-stage impeller to fit NPSH requirements, mechanically sealed, optional spacer coupling

Operating Parameters

- Flows to 4600 m³/h (20 200 gpm)
- Heads to 500 m (1640 ft)
- Pressures to 50 bar (725 psi)
- Temperatures to 95°C (200°F)

Vertical Turbine, Canned Pumps

Multistage, diffuser casing designs with large eye first-stage impeller for enhanced suction characteristics, mechanically sealed, optional spacer coupling

Operating Parameters

- Flows to 13 600 m³/h (60 000 gpm)
- Heads to 1070 m (3500 ft)
- Pressures to 100 bar (1450 psi)
- Temperatures to 230°C (450°F)

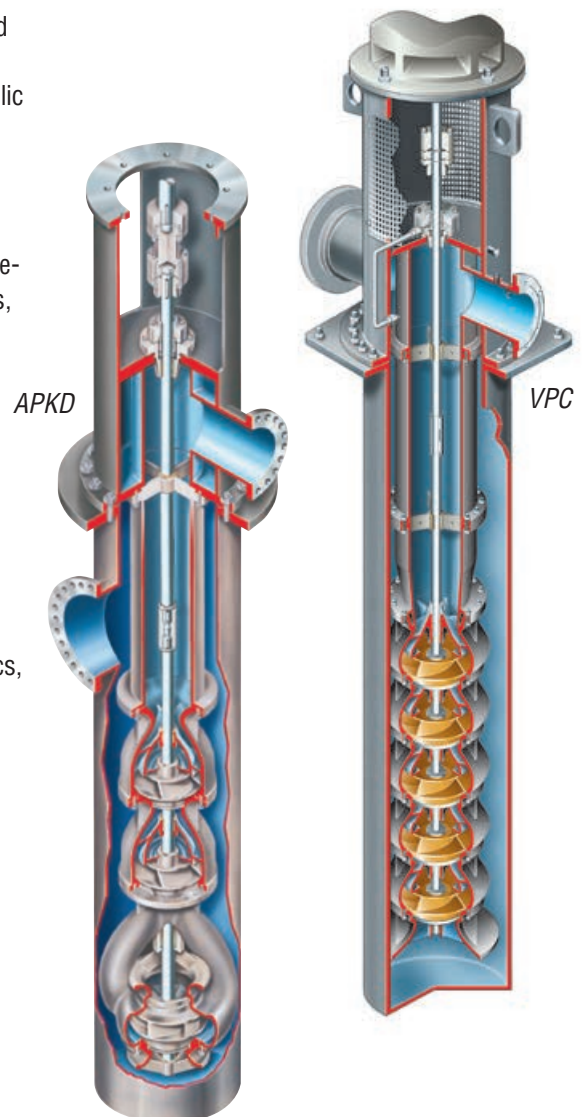



Auxiliary Services Pumps

Flowserve pumps come in a wide variety of materials and configurations to satisfy virtually all plant-wide needs.

ANSI, ISO and DIN Process Pumps

Many designs available, low-flow/high-head, self-priming, dynamic sealing, recessed impeller and in-line

Operating Parameters

- Flows to 4540 m³/h (20 000 gpm)
- Heads to 300 m (985 ft)
- Pressures to 31 bar (450 psi)
- Temperatures to 400°C (752°F)

Axially Split, Single-Stage Pumps

Heavy-duty, broad hydraulic range, high-efficiency

Operating Parameters

- Flows to 2000 m³/h (8800 gpm)
- Heads to 170 m (560 ft)
- Pressures to 21 bar (300 psi)
- Temperatures to 150°C (300°F)

Segmental Ring Section Pumps

Multistage, radially split

Operating Parameters

- Flows to 3000 m³/h (13 210 gpm)
- Heads to 1200 m (3940 ft)
- Pressures to 150 bar (2175 psi)
- Temperatures to 204°C (400°F)

Durco Mark 3™

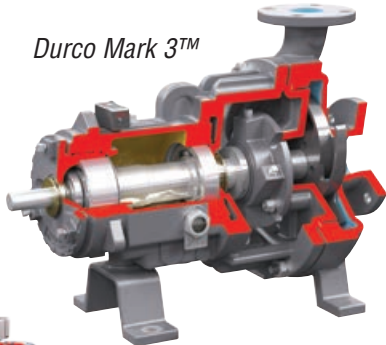

Durco Mark 3 ISO



LR

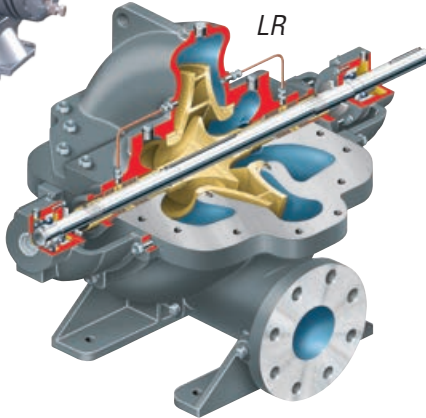

MEN

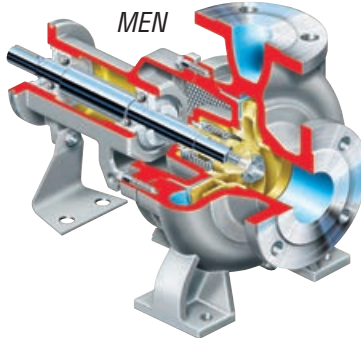

NM

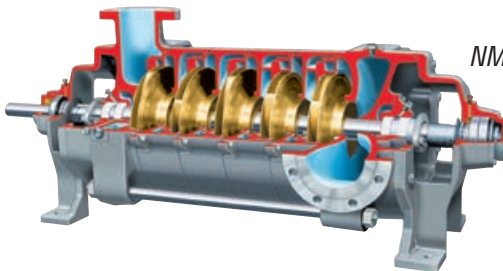

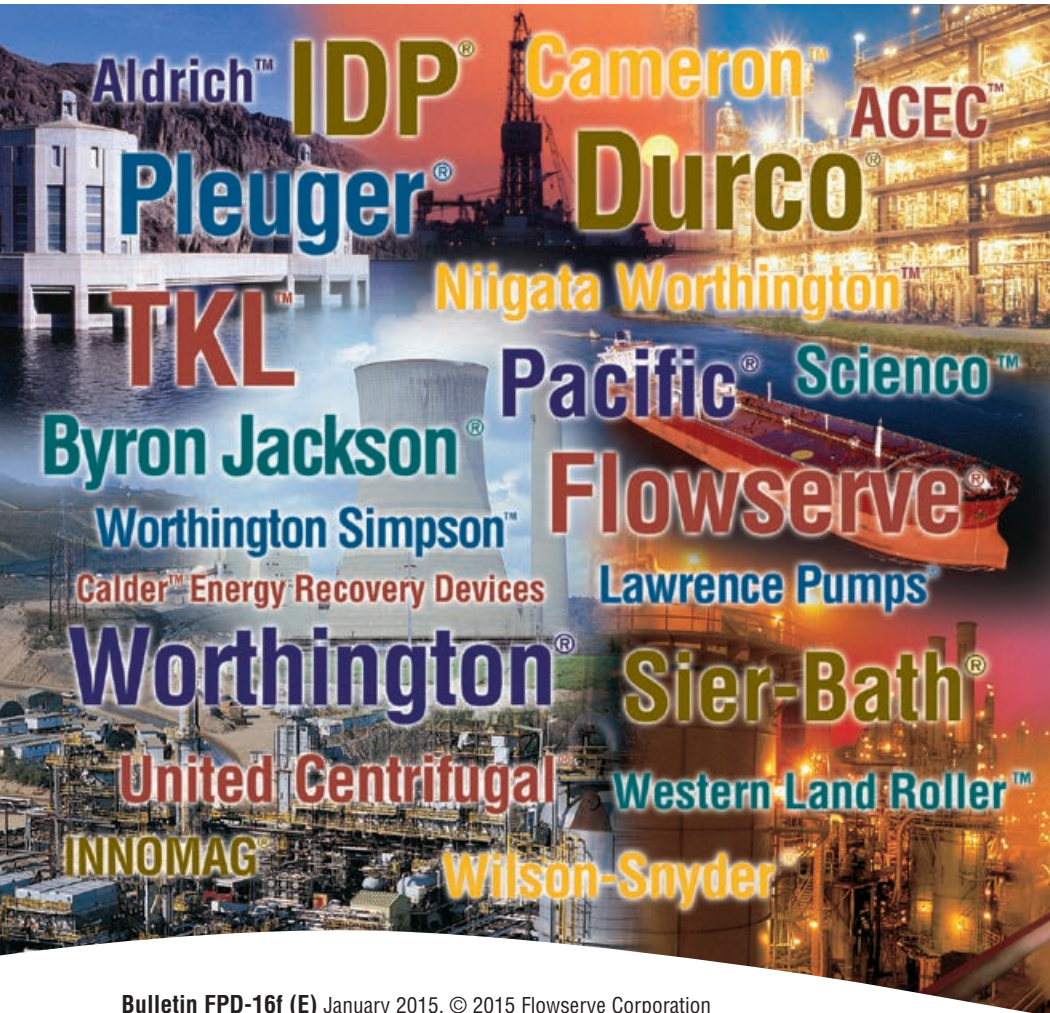

USA and Canada

Flowserve Corporation
5215 North O'Connor Blvd.
Suite 2300
Irving, Texas 75039-5421 USA
Telephone: +1 937 890 5839

Europe, Middle East, Africa

Flowserve Corporation
Parallelweg 13
4878 AH Etten-Leur
The Netherlands
Telephone: +31 76 502 8100

Latin America

Flowserve Corporation
Martin Rodriguez 4460
B1644CGN-Victoria-San Fernando
Buenos Aires, Argentina
Telephone: +54 11 4006 8700
Telefax: +54 11 4714 1610

Asia Pacific

Flowserve Pte. Ltd.
10 Tuas Loop
Singapore 637345
Telephone: +65 6771 0600
Telefax: +65 6862 2329

Bulletin FPD-16f (E) January 2015. © 2015 Flowserve Corporation

To find your local Flowserve representative:

For more information about Flowserve Corporation,
visit www.flowserve.com or call +1 937 890 5839.

flowserve.com