

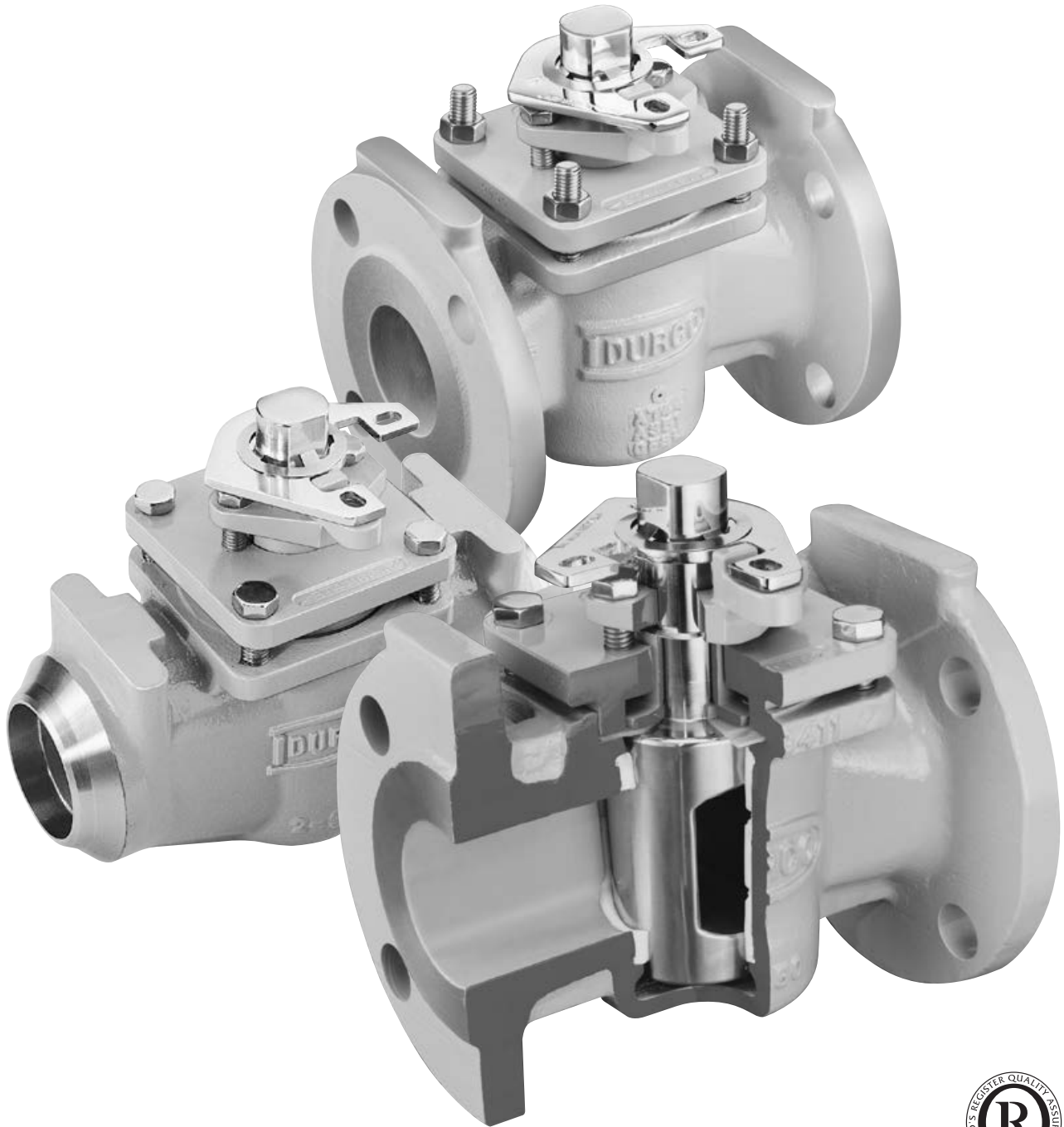

Installation, Operation and Maintenance

G4, G4ZHF and G4R

S L E E V E L I N E[®] P L U G V A L V E S



Quality
System
Certificate

Non-Lubricated Plug Valves for Chemical Service

Bulletin
DVENIM0006-05

FOREWORD

Flowserve Corporation, Flow Control Division, has established this Installation, Operating, and Maintenance Manual to facilitate field installation, operation and repair of G4, G4ZHF and G4R valves.

It is recommended that questions or concerns involving the processes described in this manual be directed to the

local Sales Representative of Flowserve Corporation. Only Flowserve replacement repair parts and assembly tooling made or designed by Flowserve Corporation should be used. Part numbers referenced in the following sections are available from Flowserve Corporation, Flow Control Division.

TABLE OF CONTENTS

SECTION	TITLE	PAGE
	FOREWORD	
I	INSTALLATION INSTRUCTIONS – FLANGED AND WELDED G4, G4ZHF, G4R	2
II	OPERATING/MAINTENANCE – G4, G4ZHF, G4R	3
III	VALVE DISASSEMBLY – G4, G4ZHF, G4R	4
IV	PRESSURE CONTAINING FASTENERS	5-6
V	A. VALVE ASSEMBLY – 1/2" & 3/4" G4, G4R	7-8
	B. VALVE ASSEMBLY – 1"-8" G4, G4R	9-10-11
VI	ASSEMBLY SPECIFICATIONS – FIRESAFE VALVES G4Z, G4ZHF, G4ZR	12-13-14
VII	RECOMMENDED SPARE PARTS	15

SECTION I

INSTALLATION INSTRUCTIONS – FLANGED AND WELDED G4, G4ZHF, G4R PLUG VALVES

FLANGED:

Installation of Flowserve flanged valves is best accomplished by locating valves in pipeline flanges, assuring all corrosion and foreign materials are removed from pipe flange, and then center gaskets with the valve flanges. Fastener or taper pins should be used to align holes and locate gaskets. Fasteners should be tightened to the corresponding valve and fastener size.

WELDING:

Flowserve Corporation, Flow Control Division recommends using only qualified welding procedures and personnel for weld installation of G4R valves.

The following precautions should be observed:

1. The valve should be inspected prior to welding to assure that no foreign materials obstruct the flow passageway and that the weld preparation is free of corrosion and physical damage.
2. The valve should be in the open position while being welded. Open position is when the flats on the plug stem are parallel with the pipeline.
3. The G4R valve contains various sleeve and diaphragm materials that have a different maximum temperature limitation. Refer to Table 1.1 for temperature limitations.
4. The valve body sleeve and diaphragm must not exceed these temperatures during welding. This includes preheats, interpasses, or post weld heat treatments, as applicable. Refer to Figure 11-1 for locations of the sleeve and diaphragm in the center valve section.

5. Welding of the G4R Valve without disassembly may be accomplished with no damage to the sleeve and diaphragm. Precautions MUST be taken to cool the valve bowl and monitor temperature. The temperature of the center or bowl area of the valve must not exceed the listed temperature for the material. Valves, sizes two inch and smaller, must be wrapped with water soaked, fire-resistant material to cool the valve bowl and inlet where the weld is to be made. Use temperature melt crayons equal to the sleeve and diaphragm rating to mark the body welding end and monitor the body temperature. Thermocouples may be attached to the welding end of the body or surface pyrometers may be used to monitor the body bowl temperature.

CAUTION: DO NOT ALLOW WATER FROM THE SOAKED WRAPPING MATERIAL TO ENTER THE WELDMENT.

**TABLE 1.1
TEMPERATURE LIMITATIONS**

MATERIAL DESCRIPTION	MAXIMUM SERVICE TEMPERATURE
Ultra High Molecular Weight Polyethylene (UMPE)	200°F (93°C)
Tetrafluoroethylene Polymer (PTFE)	400°F (204°C)
Durlon 2	450°F (232°C)
Duriron Durco 82 (DU-82)	275°F (135°C)

SECTION II

OPERATING/MAINTENANCE INSTRUCTIONS FOR G4, G4ZHF, G4R

Maintenance requirements for G4, G4ZHF and G4R valves may vary due to operating conditions of the process. Factors such as operating temperature, pressure, solids content, and frequency of cycling can influence valve performance and maintenance requirements.

Seal wear is compensated by adjusting appropriate parts. For G4, G4ZHF and G4R valves, there are three possible leak paths:

1. Top Cap (bonnet)
2. Stem
3. Line (through)

Corresponding adjustments for each leak path are as follows:
NOTE: Refer to Figure II-1 or Figure VI-1A for parts identification.

1. Top Cap (bonnet)

Leakage due to thermal or pressure cycling is eliminated by snugging the top cap fasteners (Part 3A) in a "criss-cross" pattern. This adjustment is most effective when the valve is not pressurized. It is important that the top cap fasteners not be tightened excessively and that torque values applied be within industry standard for fasteners.

2. Stem

Leakage due to wear of the diaphragm, and/or wear to the sleeve (primary seal) is eliminated by tightening the adjuster fasteners (Part 12A) in 1/4 turn increments. It is recommended that the adjuster fasteners be tightened evenly.

The valve should be operated between adjustments to assure that the plug properly seats itself into the sleeve. If leakage persists after repeated adjustments, the sleeve and diaphragm will require replacement as covered in Section V A and V B or Section VI.

3. Line (through)

Through leakage due to wear of the primary seal can be eliminated by tightening the adjuster fasteners (Part 12A) in 1/4 turn increments. It is recommended that the fasteners be tightened evenly.

The valve should be operated during adjustments to prevent excessive operating torque. Should leakage persist after repeated adjustments, the sleeve will require replacement as covered in Section V A and V B or Section VI.

FIGURE II-1
TYPICAL ASSEMBLY OF G4 AND G4R VALVE

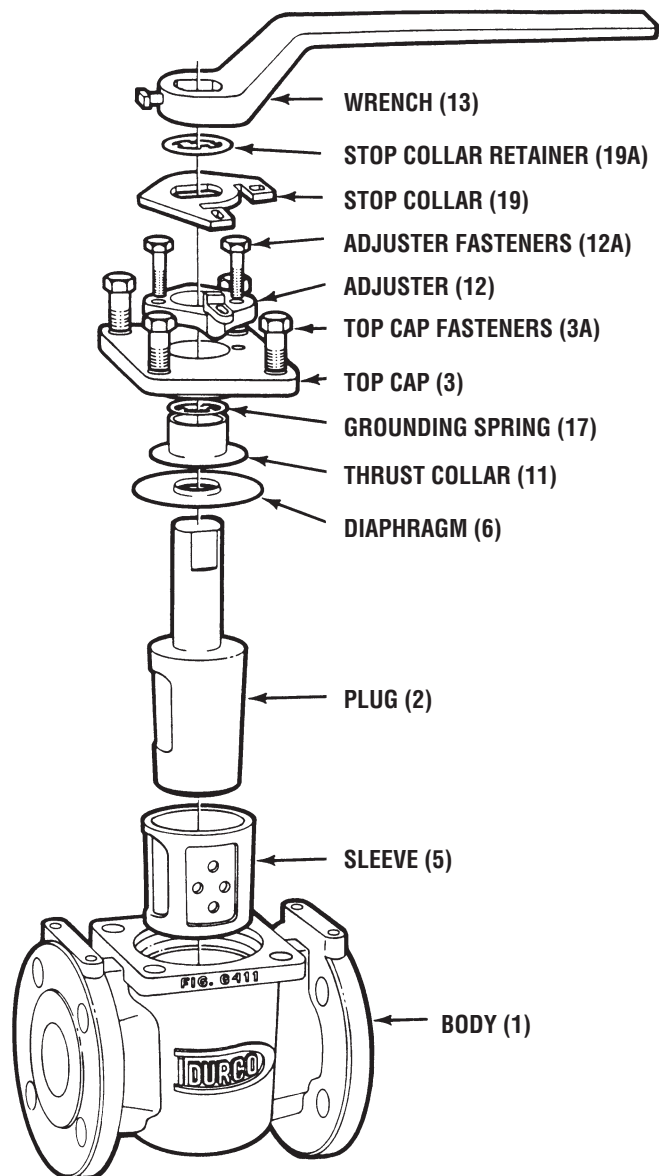

WARNING

To avoid personal injury and prevent damage to equipment, do not operate or repair this valve without observing the following procedures outlined in this manual.

SECTION III

VALVE DISASSEMBLY – G4, G4ZHF, G4R

Recommended Precautionary Measures

1. Valves must be relieved of process fluid and pressure prior to disassembly.
2. Personnel performing disassembly must be suitably protected and alert for emission of hazardous process fluid.
3. If there is a pipe plug located at the bottom bowl of the valve, DO NOT remove the pipe plug until the valve plug has been removed.

Disassembly Steps

NOTE: Refer to Figure II-1 or VI-1A for parts identification. If an actuator or gearbox operates the valve, alignment marks should be noted to assure correct orientation when reassembled. This may best be accomplished by making matching marks on the plug stem and operator housing with no burrs on the plug stem.

1. Gradually loosen adjuster fasteners (Part 12A) – DO NOT REMOVE.
2. Turn plug (Part 2) in order to raise the plug to vent any material trapped in the valve (see note below).
NOTE: If there is no upward movement of the plug (Part 2), it will be necessary to devise a method of lifting the plug upward. This may require removal of the valve operator (Step 3). This operation should be undertaken noting the above precautionary measures. Methods of plug removal must include protective measures on plug stem and plug end.
3. **WARNING: Do not loosen or remove top cap fasteners (Part 3A) when removing an operator or accessory. Remove the operator by unfastening it from the bracket.**
4. Once the plug (Part 2) has lifted, the adjuster fasteners (Part 12A) can be completely removed.

5. Gradually loosen but DO NOT REMOVE all of the top cap fasteners (Part 3A). Turn the plug until it is loose from the sleeve (Part 5) and all pressure has been vented. (Again, it may be necessary to use a mechanical means to move the plug upwards.)
6. Remove the top cap fasteners (Part 3A) and top cap (Part 3) from the plug stem (Part 2).
7. Remove the plug (Part 2) from the body (Part 1).
8. Remove the grounding spring (Part 17) and thrust collar (Part 11) from plug stem (Part 2).
9. Remove the diaphragm (Part 6) from plug stem (Part 2).
10. Inspect the valve sleeve (Part 5) for wear or damage, especially scratches near the top, bottom, and port areas. If wear or damage is excessive, the sleeve should be replaced.
11. Remove sleeve (Part 5) as follows:
NOTE: Care should be taken not to damage the internal body bore.
 - a. Using a screwdriver and mallet, cut the old sleeve through one of the port openings, top and bottom.
 - b. Grasp the sleeve with a pair of pliers while twisting, and lift the sleeve from the body.
12. Thoroughly clean all valve parts with an acceptable cleaner.
13. Inspect parts for damage. Look for marred, scratched, or rough sealing surfaces on the valve plug (Part 2).
NOTE: Reinstallation of damaged or unclean parts will ruin any replacement seals installed into the valve.

SECTION IV

PRESSURE CONTAINING FASTENERS

Material Selection

Selecting the proper fastener material is the ultimate responsibility of the customer because the supplier does not typically know in what service the valves will be used or what elements may be present in the environment. Flowserve normally supplies B7 (carbon steel) for ductile cast iron and carbon steel valves. For stainless steel and high alloy valves, B8 (stainless steel) fasteners are supplied as standard. All fasteners used must have a minimum yield strength of 40,000 PSI, a minimum elongation of 12% and be compatible with the process fluid. Determining compatibility to the process fluid goes beyond a material being resistant to general corrosion because the more important consideration is a material's resistance to stress corrosion cracking. Depending on the service, it may make sense to use B7 fasteners on high alloy valves. One such service would be marine environments because of stainless steel's susceptibility to stress corrosion cracking in chloride environments. Another key aspect of fasteners is frequent visual inspection. Because of the common practice of using steel fasteners rather than stainless steel to avoid chloride stress corrosion cracking, visual inspection is recommended to monitor the general corrosion of these fasteners. If jacketing or insulation is used on a valve,

it must be periodically removed for visual inspection of the fasteners. If you wish assistance in determining the proper fasteners to use, please refer to the attached chart.

Design & Type

The Flowserve valve design standards adopt ASME B18.2.1 (1996) as the standard for fastener type and design. This national standard requires that finished hex "head" cap screws be used when the head of the fastener is turned. A finished hex "head" cap screw and a heavy hex cap screw have a bearing surface under the head to minimize frictional resistance during tightening. They also comply to qualified body diameters and fully formed head dimensions. Cookeville Valve Operation policy is to use finished hex "head" and heavy hex "head" cap screws for all pressure retaining fasteners. This includes top caps, packing adjusters, plug adjusters, bottom caps, body halves or other pressure retaining components. Compliance is made with ANSI B18.2.2 (1987), Square and Hex Nuts, when studs and heavy hex nuts are required. Additional information on these items may be obtained from the Flowserve Corporation, Cookeville Valve Operation, Cookeville, Tennessee.

**TABLE 1
CAP SCREWS - STUDS**

HHCS - Finished Heavy Hex Head Cap Screw	Alloy identification stamp required on each piece.
HCS - Finished Hex Head Cap Screw	Certification required.
STUD - Stud	Alloy Specification (40 KSI Minimum Yield Strength, 12% Minimum El.)
Dimensions per ASME B18.2.1	
B840 -	Stainless Steel per ASTM A193, Grade B8M2 or B8M3
B7 -	Chromium - Molybdenum Alloy Steel per ASTM A193, Grade B7
B7M -	Chromium - Molybdenum Alloy Steel per ASTM A193, Grade B7M, 100% hardness tested
B7MT -	Chromium Molybdenum Alloy Steel per ASTM A193, Grade B7M, 100% hardness tested, Teflon coated, Dupont SP11C, Type B - Color blue or green
B8MC2 -	Per ASTM A193, Grade B8M (AISI Type 316), Class 2
C20 -	Carpenter C20, CB-3 (UNS N08020), ASTM B473, 40 KSI Min. Yield Strength, 12% Min. El.
HC -	Hastelloy C276 (UNS N10276), ASTM B574
I625 -	Inconel 625 (UNS N006625), ASTM B446
I825 -	Incoloy 825 (UNS N08825), ASTM B425, 40 KSI Min. Yield Strength, 12% Min. El.
IN -	Inconel 600 (UNS N0660), ASTM B166, 40 KSI Min. Yield Strength, 12% Min. El.
M -	Monel (UNS N04400), ASTM B164, Class A or B, 40 KSI Min. Yield Strength, 12% Min. El.
HB -	Hastelloy B (UNS 10665), ASTM B335
I718 -	Incoloy 718, AMS 5596B, ASTM B637
MKH -	Monel K-500, Cold drawn and aged hardened, QQN-286 and ASTM F468
L7 -	Chromium-Molybdenum Alloy Steel per ASTM A320, Grade L7
L7M -	Chromium-Molybdenum Alloy Steel per ASTM A320, Grade L7M, 100% hardness tested
L7T -	Chromium-Molybdenum Alloy Steel per ASTM A320, Grade L7, Teflon coated, Dupont SP11C, Type B - Color green
L7MT -	Chromium-Molybdenum Alloy Steel per ASTM A320, Grade L7M, 100% hardness tested, Teflon coated, Dupont SP11C, Type B - Color green
N -	Nickel per ASTM B160 (UNS N0220), 40 KSI Min. Yield Strength, 12% Min. El.
B7YC -	Chromium-Molybdenum Steel per A193, Grade B7, Yellow Zinc Dichromate Plated

SECTION IV

PRESSURE CONTAINING FASTENERS

**TABLE 2
NUTS**

HN -	Finished Heavy Hex Nut
XN -	Finished Hex Nut
HXN -	Regular Heavy Hex Nut
Dimensions per ANSI B18.2.2	
Alloy identification stamp is required on each piece.	
Certification required.	
8 -	304 Stainless Steel per ASTM A194, Grade 8
8M -	316 Stainless Steel per ASTM A194, Grade 8M
2H -	ASTM A194, Grade 2H
2HM -	ASTM A194, Grade 2HM
7M -	ASTM A194, Grade 7M, 100% hardness tested
7MT -	ASTM A194, Grade 7M, 100% hardness tested, Teflon coated, Dupont SP11C, Type B - Color green
M -	Monel (UNS N04400), ASTM B164, Class A or B, or QQN-281, Class B
HB -	Hastelloy B (UNS N10665), ASTM B335
HC -	Hastelloy C276 (UNS N10276), ASTM B574
I625 -	Inconel 625 (UNS N06625), ASTM B446
I718 -	Incoloy 718, AMS 5596B, ASTM B637
I825 -	Incoloy 825 (UNS N08825), ASTM B425
L7 -	Chromium-Molybdenum Alloy Steel per ASTM A194, Grade 7
L7M -	Chromium-Molybdenum Alloy Steel per ASTM A194, Grade 7M, 235 BHN Max, ASTM A320, Section 9
MKH -	Monel K-500, Cold drawn and aged hardened, QQN-286 and ASTM F467
8F -	303 Stainless Steel per ASTM A194, Grade 8F
2HYC -	ASTM A194, Grade 2H, Yellow Zinc Dichromate Plated

SECTION V

A. VALVE ASSEMBLY – 1/2" & 3/4" G4, G4R

Valve assembly will require usage of a repair tooling kit that is specific to the size of the valve. These kits can be obtained from Flowserve FCD, Cookeville, TN.

1. Apply Durco Seal 1028B to the inside of the tapered bore in the body and permit to dry before assembly. RAD-1 material is used for nuclear applications.
2. Assemble sleeve into body with a coining die, part #BY81917A. Position coining die so locating pins are located in bonnet flange holes in body. Position sleeve in coining die so that sleeve holes are centered over body ports (Figure V A-1). Place push rod and push rod guide in coining die and push sleeve into body until push rod stops on push rod guide (Figure V A-2).

FIGURE V A-1
ASSEMBLE SLEEVE

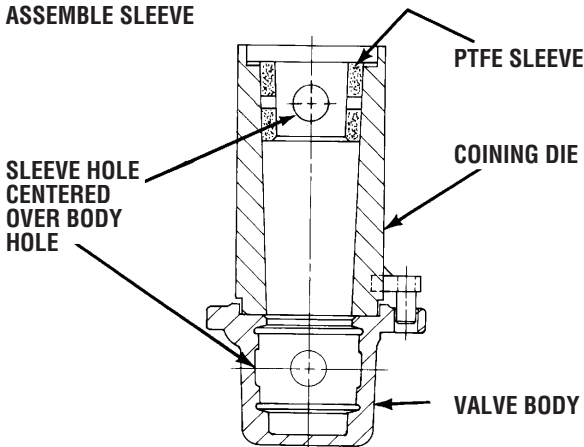
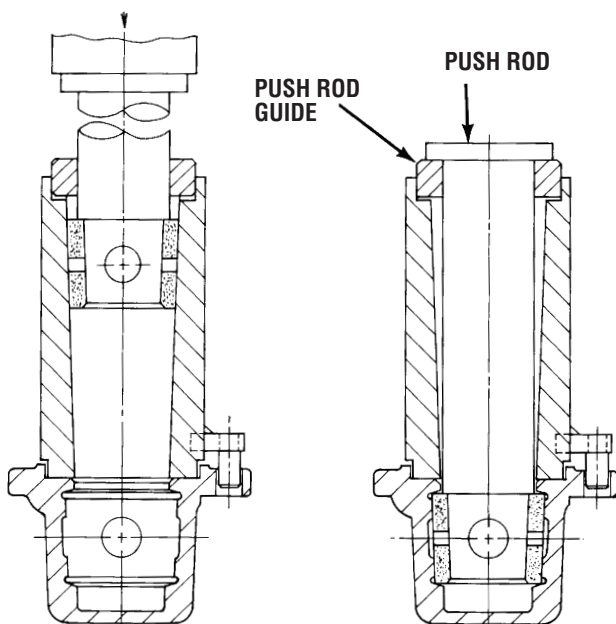

FIGURE V A-2
PUSH SLEEVE IN BODY



3. Size sleeve. Check sleeve in body to make sure sleeve vent holes are still centered between body ports. Apply a light coat of silicone lubricant to sizing Plug #1 and sizing Plug #2, part #BY80017B & C. Push sizing Plug #1 into sleeve until the sizing plug flange bottoms against the counter-bore of the valve body. Remove #1 sizing plug and now push #2 sizing plug in the same manner, but HOLD SIZING PLUG IN PLACE for 15 SECONDS (Figure V A-3).

1. Rough Size With Plug #1
2. Finish Size With Plug #2 (Hold for 15 Seconds)

FIGURE V A-3
SIZE SLEEVE

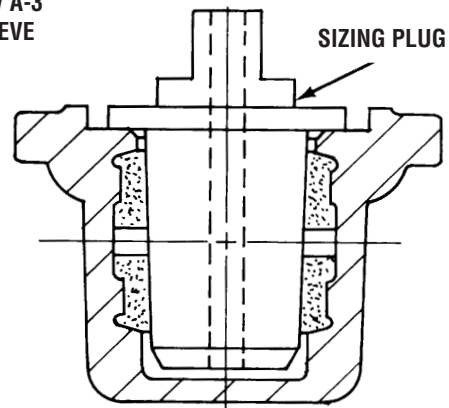

4. The plug stem and diaphragm guide are to be checked for nicks or burrs before installing the diaphragm. Nicks on these surfaces could result in scratches on the lip of the diaphragm. Assemble diaphragm over plug stem with the aid of the diaphragm guide, part #BY77543A, and assembly tool, part #BY80019A. (Figure V A-4).

FIGURE V A-4

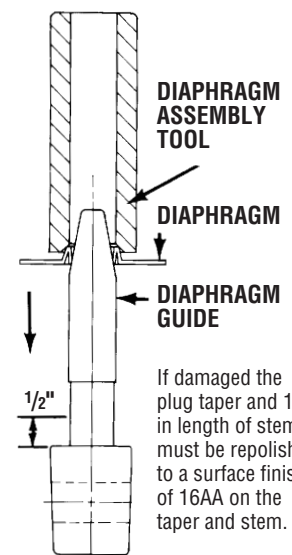

ASSEMBLE DIAPHRAGM
ON PLUG

5. Preassemble the top cap and adjuster, adjusting the cap screws so that the bottom of the thrust collar is flush with the bottom face of the top cap (Figure V A-5).

If damaged the plug taper and 1/2" in length of stem must be repolished to a surface finish of 16AA on the taper and stem.

SECTION V

A. VALVE ASSEMBLY – 1/2" & 3/4" G4, G4R

- Remove thrust collar from top cap and assemble over the plug stem (Figure V A-6). With the thrust collar guide, part #BY77545A, centering the thrust collar, force down (with arbor press) thrust collar guide to seat the diaphragm stem seal in the thrust collar.

**FIGURE V A-5
PRESET ADJUSTER, THRUST COLLAR AND TOP CAP
SET ADJUSTER CAP SCREWS TO MAKE ADJUSTER PARALLEL TO TOP CAP**

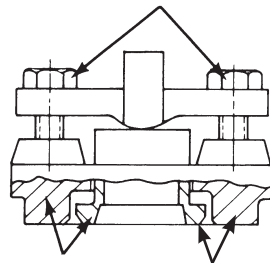

BOTTOM OF TOP CAP AND THRUST COLLAR FLANGE TO BE FLUSH

- Place grounding spring over plug stem sliding it down to the thrust collar.

- Apply a thin, even film of silicone or customer approved lubricant to the entire surface of the 2° plug taper.

- Take plug (preassembled with diaphragm, thrust collar and grounding spring) and place it into body. Using a soft head mallet, tap top of plug slightly to seat plug into sleeve taper. The plug at this time will be setting up above the body counterbore approximately 1/4". The plug ports should be lined up in an open position.

**FIGURE V A-6
SEAT THRUST COLLAR ON DIAPHRAGM**

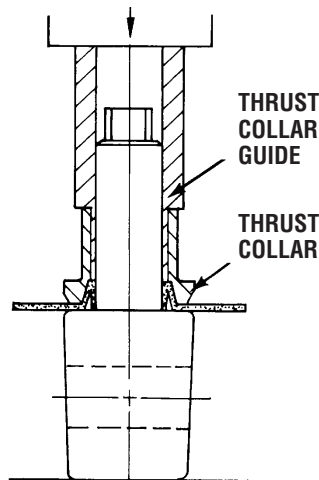

- Place the top cap assembly over plug and slide it down until it rests on the thrust collar.

- Assemble four fasteners thru top cap and body. With "U" shaped push plate, part #BY80020A, resting on the top cap (Figure V A-7), force the top cap down (with arbor press or pneumatic clamping arrangement) to seat the top cap against the valve body counterbore. While holding the cap in this position, assemble nuts on underside of body flange to a finger tight position against the flange. Coat the fastener threads with Loctite® 242.

- Tighten the four top cap fasteners to 7 ft-lbs using a torque wrench. Reference Torque Table #1a & 1b on page 11.

FIGURE V A-7

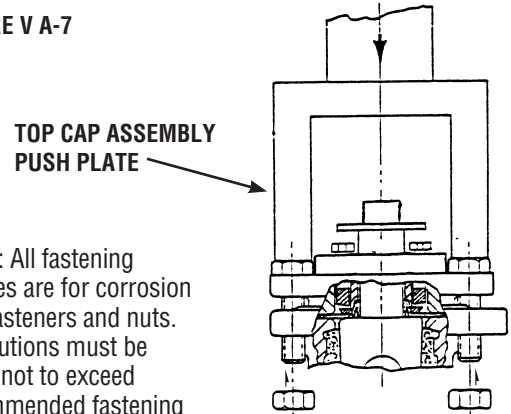

NOTE: All fastening torques are for corrosion free fasteners and nuts. Precautions must be taken not to exceed recommended fastening torques.

ASSEMBLE TOP CAP ASSEMBLY OVER PLUG AND PUSH INTO BODY

- Loosen the adjuster fasteners to approximately 3/16" above adjuster. Then rotate the valve plug back and forth 3 times, making it rise upward.

- Retighten adjuster fasteners to a torque of 10 to 12 in-lbs. The height of the plug port should now be positioned approximately 1/16" above to flush with the body port.

- Rotate plug back and forth a couple times to make sure the stops and ports line up properly. The final assembled valve should look similar to Figure V A-8.

- LEAK TESTING:** Anytime a valve has been modified in any manner, including fastener changes, it should be retested. Normal testing using gas, should be at 150 PSI for Class 150 and 300 PSI for Class 300 valves from 1/2" through 6". It should be noted, however, that this test does not meet the requirements of ANSI, API or MSS. For test procedures complying with these specifications, refer to the appropriate published specification.

**FIGURE V A-8
ASSEMBLED VALVE**

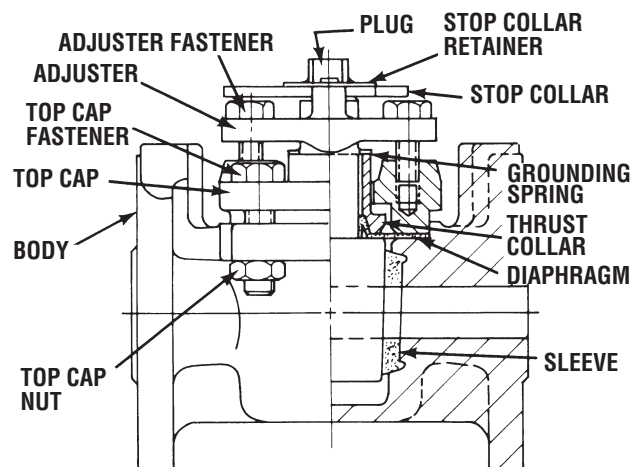

SECTION V

B. VALVE ASSEMBLY – 1"-8" G4, G4R

Due to the tooling and associated equipment required (presses, fixtures, etc.) to rebuild 10"-14" size valves, it is highly recommended they be returned to the factory or a Flowserve Authorized Black Tie Valve Rebuilder for repair and rebuild. Many valves made by Flowserve Corporation handle corrosive chemicals which may be injurious to property or personnel. Valves returned without proper attention given to the safety requirements will be shipped back to the consignor collect.

NOTE: Part number reference is shown in Figure V B-7.

1. Apply Durco Seal 1028B to the inside of the tapered bore in the body and permit to dry before assembly. RAD-1 material is used for nuclear applications.
2. Apply a light coating of oil or silicone to the interior of the coining die or to the O.D. of the sleeve. Position the sleeve in the coining die, part series #BY79542A, so that the diagonal opposite sides of the sleeve port will lock behind the metal lips in the body (Figure V B-2). The sleeve is then pushed directly through the coining die into the valve body until the sleeve drops below the top counterbore of the valve body (Figure V B-1).

FIGURE V B-1

Push sleeve directly through coining die until sleeve drops below top counterbore of the valve body.

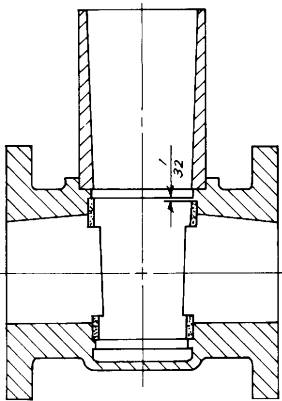

3. A special plug, part series #BY79664A, containing retractable or removable blades is lowered into the body with the blades retracted or removed. The blades are then installed or extended and a counter clockwise rotary motion is applied to the plug engaging the two remaining diagonal opposite sleeve port openings and pulling them until they fall behind the body port

FIGURE V B-2

A special plug with retractable or removable blades engages the two remaining sleeve ports and pulls them until they fall behind the body port lips.

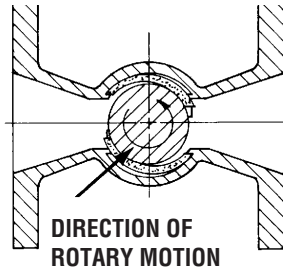
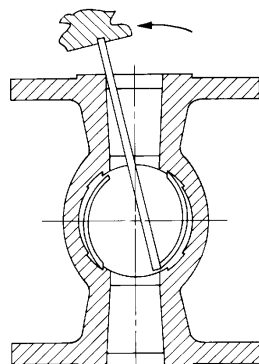

FIGURE V B-2A
Optional assembly operation for 1" & 1½" G-4 Valves

Care must be exercised to ensure that the bar does not slip and gouge or tear the sleeve.



lips. The plug is then rotated back to its original position, and the blades are then removed or retracted. The plug is then removed from the body (Figure V B-2). In the 1" and 1½" sizes, a bar may be substituted for the locking plug. See Figure V B-2A for a description of this operation.

FIGURE V B-3

The sizing plug is pushed into the sleeve until the sizing plug flange bottoms against the counterbore of the valve body.

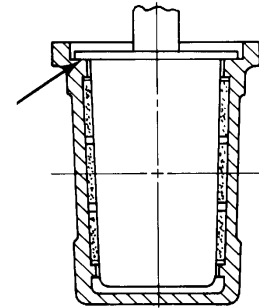

4. Apply a thin film of oil on the sizing plug, part series #BY79555A, and push it into the sleeve until the sizing plug flange bottoms against the counterbore of the valve body (Figure V B-3). Allow the sizing plug to remain in this position for one minute.

FIGURE V B-4

Thrust collar to be flush with gasket surface of top cap.

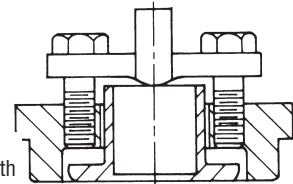

FIGURE V B-5

If damaged the plug taper and 1/2" in length of stem must be repolished to a surface finish of 16AA on the taper and stem.

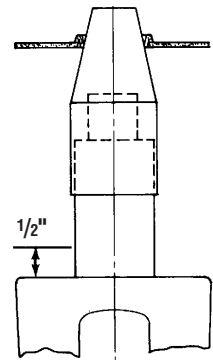
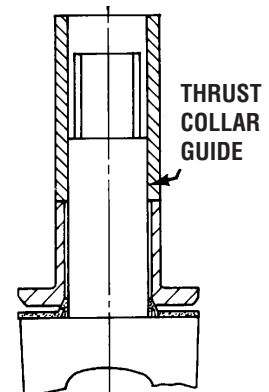

FIGURE V B-6



5. Place the top cap (Part 3) and adjuster (Part 12) over the thrust collar. The adjuster fasteners should be threaded into the top cap until flush with the bottom (Figure V B-4).
6. The diaphragm (Part 6) is assembled over the plug stem with the aid of the G4 diaphragm guide, part series #BY77543A (Figure V B-5) and #BY79581A. The plug stem and diaphragm guide should be checked for nicks before installing the diaphragm. Nicks on these surfaces could result in scratches on the lip of the diaphragm.
7. The thrust collar is then assembled over the plug stem and driven into place through the use of the thrust collar guide, part series #BY77545A, and an arbor press (Figure V B-6).

SECTION V

B. VALVE ASSEMBLY – 1"-8" G4, G4R

8. Place the grounding spring (Part 17) over the plug stem.
9. Place the top cap and adjuster over the plug stem. Place this subassembly into the valve body using an arbor press to hold the top of the plug flush with the counterbore. (The bottom of the plug ports should be lined up with the bottom of the body ports.) Push down on the press until the top cap gasket pad seats firmly against the body counterbore. Apply thread locking compound to the threads of the top cap fasteners. Tighten the top cap fasteners (Part 3A) to a value consistent with industry standards for size and alloy type. Ref. Torque Table #1a & #1b on page 11.
10. Remove the valve from the arbor press, loosen the adjuster fasteners, and operate the plug several times. It will turn hard at first but will then loosen and turn freely.
11. Tighten the adjuster fasteners (Part 12A) until a reasonable turning torque (Ref. Table #2 on page 11) is obtained. The 8" and larger valves are placed in an oven at 200°F for a minimum of six hours prior to final adjustment with the plug in the open position. After removal from the oven and valve has cooled, loosen the adjuster fasteners. Turn the plug several times. Retighten the adjuster fasteners until a reasonable plug turning torque is obtained. The height of the plug port should be positioned approximately 1/16" above to flush with the body port.
12. Place the stop collar (Part 19A) and retainer on the plug stem. The stop collar should point in the direction of flow.
13. The valve is now ready for test and use.
14. LEAK TESTING: Anytime a valve has been modified in any manner, including fastener changes, it should be retested. Normal testing using gas, should be at 150 PSI for Class 150 and 300 PSI for Class 300 valves from 1/2" through 6". It should be noted, however, that this test does not meet the requirements of ANSI, API or MSS. For test procedures complying with these specifications, refer to the appropriate published specification.

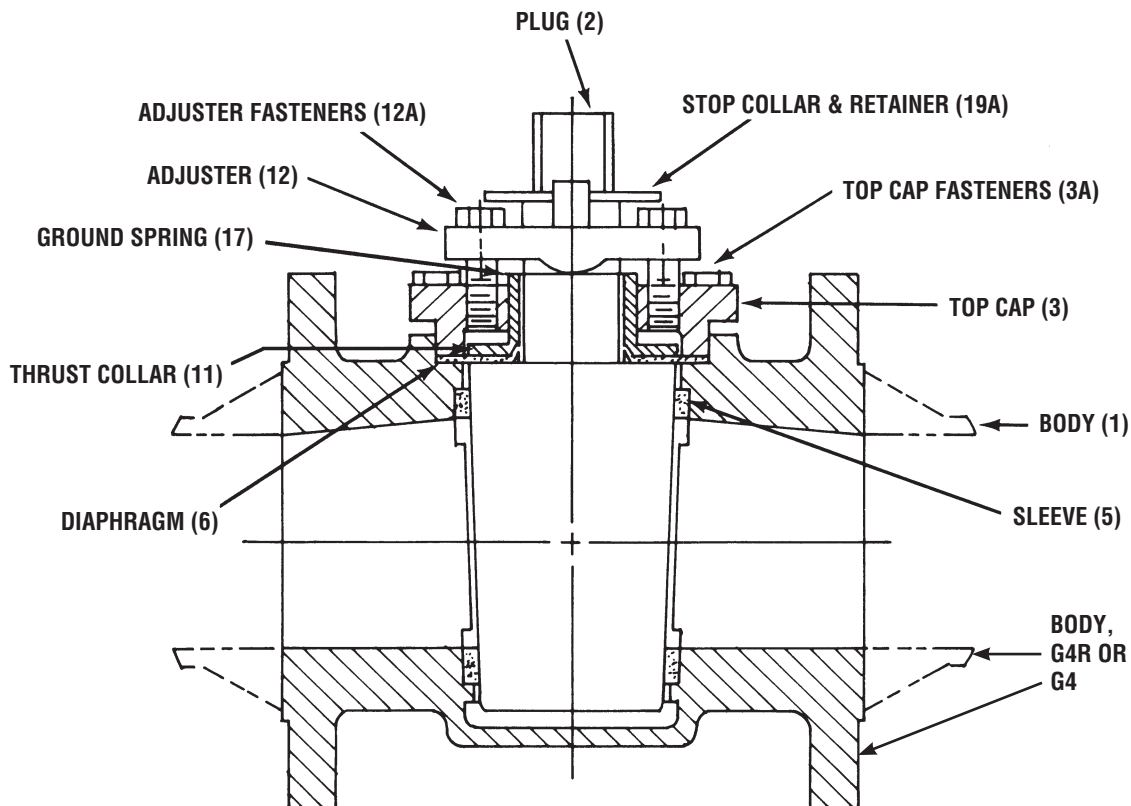

**FIGURE V B-7
ASSEMBLED G4 OR G4R VALVE**

SECTION V

B. VALVE ASSEMBLY – 1"-8" G4, G4R

Table #1a *Apply Loctite® 242 to fastener threads, top cap only.
Torque Required On Top Cap Fasteners Of Class 150 G4 Valves

VALVE SIZE	1/2-3/4"	1"	1 1/2"	2"	3"	4"	6"	8"
MAX. TORQUE (FT-LBS)	7	7	7	12	21	31	62	62

Table #1b *Apply Loctite® 242 to fastener threads, top cap only.
Torque Required On Top Cap Fasteners Of Class 300 G4 Valves

VALVE SIZE	1/2-3/4"	1"	1 1/2"	2"	3"	4"	6"	8"
MAX. TORQUE (FT-LBS)	7	13	13	20	31	62	125	115

Table #2
Torque On Plug Adjusters Of G4 Valves, 150# And 300#

VALVE SIZE	1/2-3/4"	1"	1 1/2"	2"	3"	4"	6"	8"
MAX. TORQUE (IN-LBS)	10	35	35	35	50	80	180	372

Loctite® is a registered trademark of the Loctite Corp.

SECTION VI

ASSEMBLY SPECIFICATIONS – FIRESAFE VALVES G4Z, G4ZHF, G4ZR

Note: Part number reference is shown in Figure VI-1A.

FIGURE VI-1A
TYPICAL ASSEMBLY OF G4Z AND G4ZHF

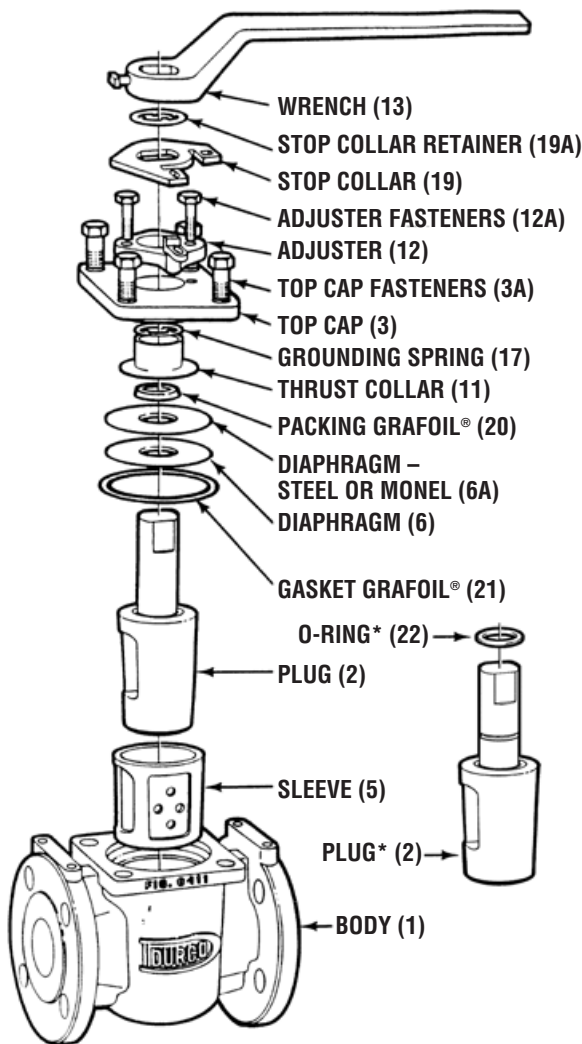

©Grafoil is a registered trademark of Union Carbide Corporation.
 *For use on G4Z-HF Alkylolation Valve.

1/2"-4"

1. Normal procedures for field replacement of one piece sleeves are to be followed for inserting the sleeve, Section V A (1/2" & 3/4"), steps 1-3 or Section V B (1"-8"), steps 1-4.
2. The firesafe top seal assembly differs from the standard G4 top seal and is completed per the following instructions.

3. The PFA diaphragm (Part 6) is to be flared on a tapered bar just enough to slip over the plug stem (Figure VI-1).

FIGURE VI-1

Flare PFA diaphragm over tapered bar.

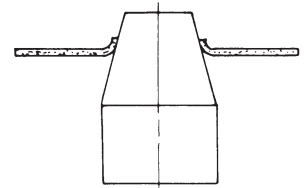
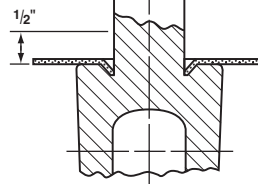

FIGURE VI-2

Place PFA diaphragm over plug stem with lip down using the diaphragm guide.

If damaged the plug taper and 1/2" in length of stem must be repolished to a surface finish of 16AA on the taper and 63AA on stem.



4. The PFA diaphragm (Part 6) is placed over the plug stem with the lip down using the diaphragm guide #BY77543A and #BY79581A (Figure VI-2). The plug stem should be checked for nicks before installing the PFA diaphragm. Nicks on this surface could result in scratches on the lip of the diaphragm.

5. The metal diaphragm (Part 6A) is placed over the plug stem and the hole enlarged just enough to slip down on the stem (Figure VI-3).

FIGURE VI-3

Flare metal diaphragm over plug stem with lip up.

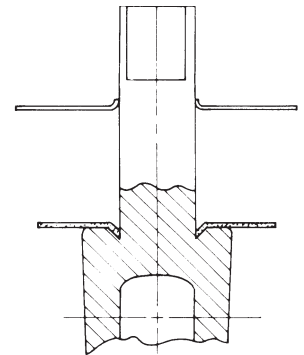
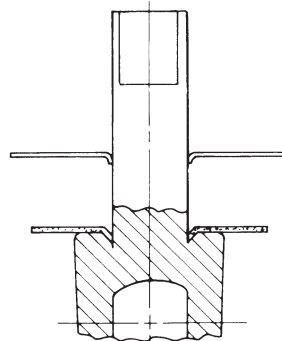

FIGURE VI-4

Metal diaphragm is removed and reassembled with lip down.



6. The metal diaphragm is then removed and replaced with the lip down (Figure VI-4).

7. The Grafoil packing ring (Part 20) is placed over the stem (Figure VI-5).

FIGURE VI-5

Grafoil packing ring placed over stem.

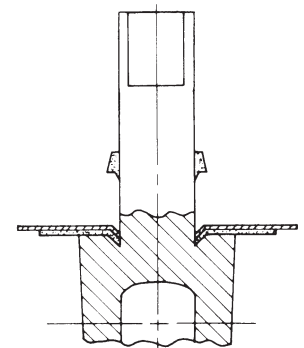

SECTION VI

ASSEMBLY SPECIFICATIONS – FIRESAFE VALVES G4Z, G4ZHF, G4ZR

- The thrust collar (Part 11) is then assembled over the plug stem and driven into place through the use of the thrust collar guide, part series #BY77545A, and arbor press (Figure VI-6).

FIGURE VI-7

Grafoil gasket placed on metal diaphragm using a bonding material.

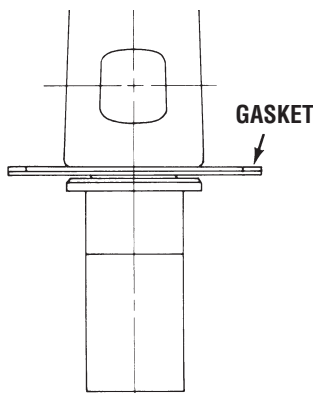
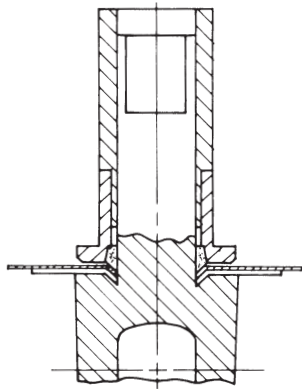

FIGURE VI-6

Packing and thrust collar driven into place.



- Continue to assemble the valve per Step 8 of Section V A for the 1/2"-3/4" size valves or Section V B for the 1"-4".

6"-8"

Due to the tooling and associated equipment required (presses, fixtures, etc.) to handle 10"-14" size valves, it is highly recommended they be returned to the factory for repair and rebuild.

- Normal procedures for field replacement of one piece sleeves are to be followed for inserting the sleeve Section V B, steps 1-4.
- The firesafe top seal assembly differs from the standard G4 top seal and is completed per the following instructions.
- The PFA diaphragm (Part 6) is to be flared on a tapered bar just enough to slip over the plug stem (Figure VI-1).
- The PFA diaphragm is placed over the plug stem with the lip down (Figure VI-2). The plug stem should be checked for nicks before installing the PFA diaphragm. Nicks on this surface could result in scratches on the lip of the diaphragm.
- The thrust collar (Part 11) and thrust collar guide, part series #BY77545A, are to be installed over the plug stem and loaded by an arbor press to flatten the PFA firesafe diaphragm. Remove the thrust collar and thrust collar guide.

- The entire assembly is turned over and the Grafoil gasket placed on the metal diaphragm (Figure VI-7). A small amount of rubber cement is placed on the Grafoil in several places to cause it to adhere to the metal diaphragm.

- The metal diaphragm (Part 6A) is placed over the plug stem and the hole enlarged just enough to slip down on the stem (Figure VI-3).
- A thin coat of silicone oil is applied to the down edge of the metal diaphragm. The diaphragm is then placed over the plug stem with the lip down (Figure VI-4).
- The Grafoil packing ring (Part 20) is placed over the stem (Figure VI-5).
- The thrust collar (Part 11) is then assembled over the plug stem and driven into place through the use of the thrust collar guide and arbor press (Figure VI-6). Place the plug (Part 2) into the body in the open position.
- The Grafoil top cap gasket (Part 21) is to be installed with the tapered or small edge diameter down or placed against the valve counterbore. The plug is pushed down until it is flush with the bottom of the body port in order to check the diaphragm fit inside the Grafoil gasket for clearance. The PFA diaphragm must not ride on the Grafoil gasket but should fit just inside the Grafoil.
- The top cap (bonnet) (Part 3) and adjuster assembly is installed and the plug is pushed down in the open position again until the bottom of the port is flush with the body part and the top cap bottoms firmly on body counterbore. The top cap must be checked before installation to ensure there is no chamfer on outside edge of the cap. The inside edges are to have a break corner chamfer only.
- The top cap is visually located to be evenly spaced inside the body counterbore. The side of the top cap compression flange is equally spaced with the side wall of the body counterbore. Fasteners should be installed and tightened to 5 ft-lb torque to prevent movement of the cap during initial torquing.
- While continuing to hold the open plug in a flush condition with the body, the top cap fasteners (Part 3A) are torqued in 50 ft-lb increments. Tighten in a crisscross method to the following values using a calibrated torque wrench. The adjuster fasteners (Part 12A) are completely loosened for this step.

Size	Torque
6"	100 ft-lb
8"	115 ft-lb

- The top cap (Part 3) is then relieved from compression and removed. The Grafoil gasket (Part 21), PFA diaphragm (Part 6), metal diaphragm (Part 6A) and Grafoil packing ring (Part 20) are visually checked for misalignment.

SECTION VI

ASSEMBLY SPECIFICATIONS – FIRESAFE VALVES G4Z, G4ZHF, G4ZR

- 15. Care must be taken when lifting the packing ring/metal diaphragm as to prevent damage or wrinkling to the sealing areas of the diaphragm. Should the metal diaphragm be wrinkled in the sealing area, the top cap is to be reworked for flatness and surface finish. The diaphragm is to be replaced and repeat steps 11 through 13.
- 16. Slight flare up of 1/16" on the outer diameter edge of the metal diaphragm is permitted but if excess bending occurs, the metal diaphragm must be custom fitted to the body counterbore while located on the plug stem.
- 17. Uneven gasket compression to the Grafoil (Part 21) or PFA diaphragm gasket (Part 6) is cause for rejection and replacement of those parts.
- 18. Once it has been determined that the gaskets fit properly, the top cap (Part 3), grounding spring (Part 17), and thrust collar assembly (Part 11) are reinstalled and steps 11 through 13 are repeated. Continue to tighten the top cap fasteners in 50 ft-lb increments in a crisscross fashion to the levels found in Table #1a & 1b on page 11.

NOTE: All fastening torques are for Loctite® coated, corrosion free fasteners and nuts. Extreme care must be taken

to prevent overstressing fasteners and subsequent valve parts by fastening in excess of industry standards for appropriate size and alloy fasteners. Ref. Torque Table #1a & 1b on page 11.

- 19. The plug is turned a minimum of three times and the sleeve is checked on all four seal zones for tears.
- 20. With the plug in the open position, adjuster fasteners (Part 12A) are then torqued to the following levels: Ref. Table #2. The height of the plug port should be positioned approximately 1/16" above, to flush with the body port.

Size	Torque
6"	15 ft-lb
8"	31 ft-lb

- 21. Operate the plug a minimum of three times.
- 22. The gear box or actuator is installed with the plug set in the open position and the open position adjusting screw is then locked. Careful attention is required to set the gear box stop screw at 90° rotation for the closed position. A protractor may be used to check for 90° rotation or alignment scribes may be noted on the gear box cover.

Selection, Installation, Operation and Maintenance

Flowserve Corporation has established industry leadership in the design and manufacture of its products. When properly selected, each product is designed to perform its intended function safely during its useful service life. However, it is necessary that Flowserve customers be fully aware of their responsibilities when using these products.

Each Flowserve valve product may be used in numerous applications under a wide variety of industrial service conditions. Although Flowserve can, and often does, provide general guidelines, it is obviously not possible to provide application specific data and warnings for all conceivable applications. The purchaser/end user must therefore assume the ultimate responsibility for the proper selection, installation, operation and maintenance of the products. Read the appropriate IOM before installation, operating or repairing any valve. The purchaser/end user should train its employees and/or contractors in the safe use of the Flowserve products in connection with the purchaser's manufacturing processes.

Flowserve will continue to provide its customers with the best possible products and service available. We do not recommend substituting surplus or remanufactured valves over new Durco valves or those repaired in an authorized service center. Should you have any questions about these provisions or about Flowserve products in general, please contact your local Flowserve valve representative, who will be happy to help.

SECTION VII

RECOMMENDED SPARE PARTS

Named parts shown below by respective valve are recommended spare parts for that valve model.

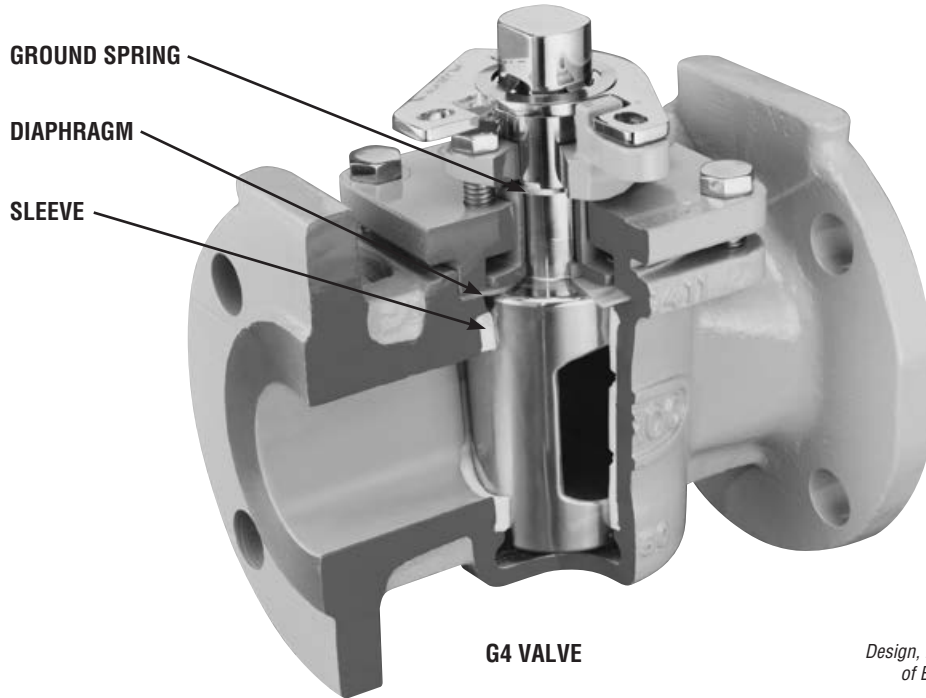

*Design, Manufacture, and In-house Repair
of Ball, Butterfly and Plug Valves
in Cookeville, TN*

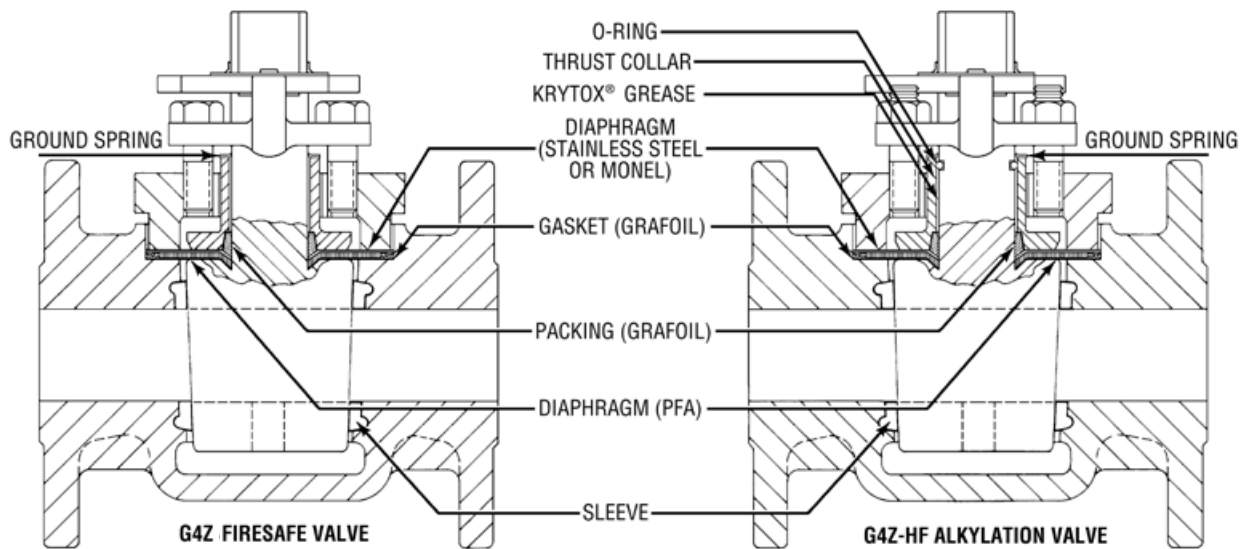

© Krytox is a registered trademark of DuPont.

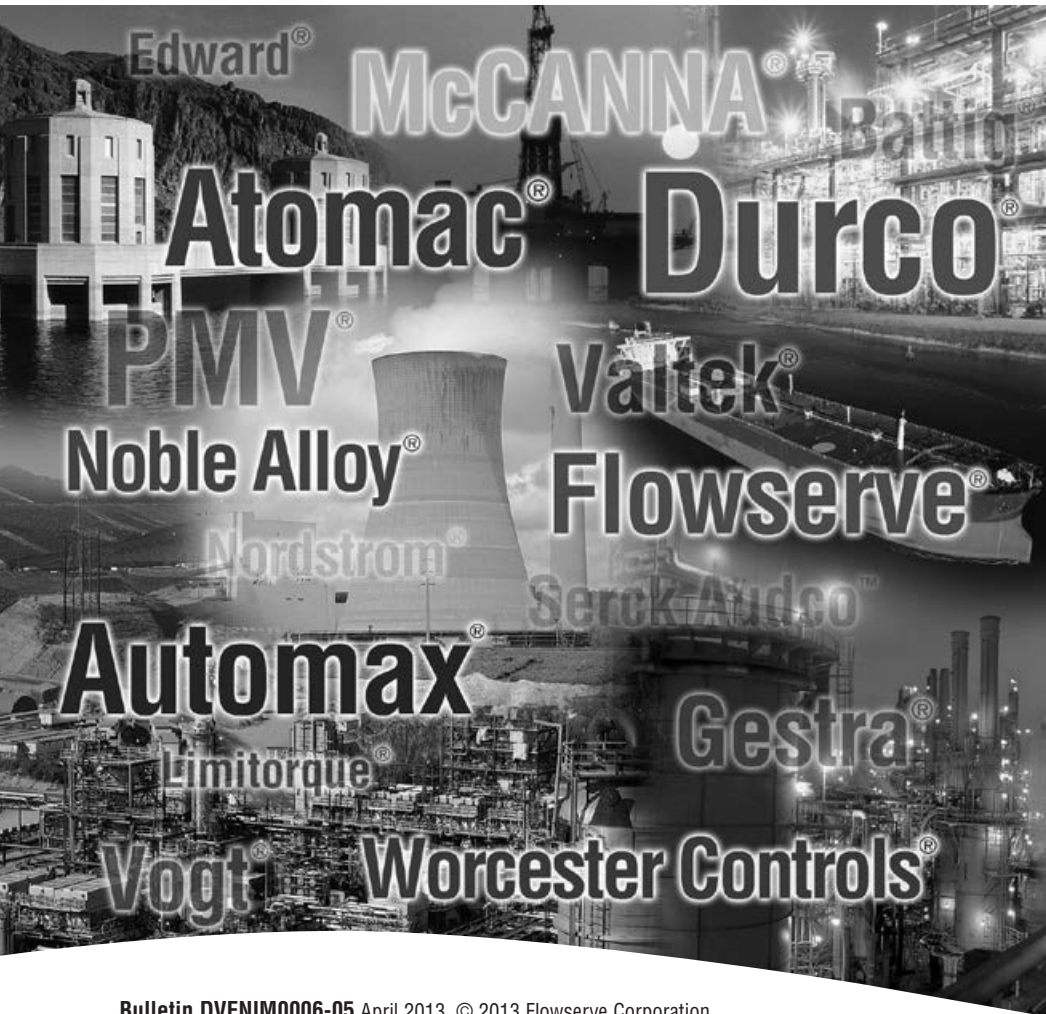

Flowserve Ahaus GmbH

Von Braun Straße 19a
D-48683 Ahaus
Germany
Phone: +49 2561 686-0
Fax: +49 2561 686-39

Flowserve Pte. Ltd.

12 Tuas Avenue 20
Republic of Singapore 638824
Phone: +65 862 3332
Fax: +65 862 2800

Flowserve Corporation

1978 Foreman Drive
Cookeville, Tennessee 38501, USA
Phone: +1 931 432 4021
Fax: +1 931 432 3105

Bulletin DVENIM0006-05 April 2013. © 2013 Flowserve Corporation

To find your local Flowserve representative:

For more information about Flowserve Corporation,
visit www.flowserve.com or call +1 937 890 5839.