



USER INSTRUCTIONS

Limitorque™ V Series

FCD LMENIM3601-02 AQ 09/17

*Installation
Operation
Maintenance*



Contents

1 Introduction	4
1.1 Purpose	4
1.2 User Safety	4
2 Inspection, Installation and Mounting Procedures	5
2.1 Initial Inspection and Storage Instructions	6
2.2 Inspection and Recording	6
2.3 Storage Procedure	7
2.4 Safety Precautions	7
2.5 Safety Practices	7
2.6 General Mounting Instructions	7
2.7 Stem Cover Mounting Instructions	9
3 Lubrication	10
4 Product Weights	11
5 Disassembly and Reassembly Instructions	12
5.1 Disassembly and Reassembly of V0 through V9	12
5.2 Disassembly and Reassembly of V35H through V9H	15
5.3 Disassembly and Reassembly of Single Reduction Spur Gear Attachment (1S)	18
5.4 Disassembly and Reassembly of Double Reduction Spur Gear Attachment (ISD)	20
6 How to Order Parts	22

Figures

Figure 2.1 – V Exploded View	5
Figure 2.2 – VH Exploded View	6
Figure 5.1 – V0 – V9 Assembly View	14
Figure 5.2 – V35H – V9H Assembly View	17
Figure 5.3 – V0 – V9, and V35H – V9H Spur Gear Attachment (1S) Exploded View	19
Figure 5.4 – V0 – V9, and V35H – V9H Spur Gear Attachment (1SD) Exploded View	21

Tables

Table 3.1 – Lubricants	10
Table 4.1 – V Gearbox Weights	11
Table 4.2 – VH Gearbox Weights	11
Table 5.1 – V0 Through V9 Parts List	14
Table 5.2 – V35H Through V9H Parts List	17
Table 5.3 – V and VH Spur Gear Attachment (1S) Parts List	19
Table 5.4 – V and VH Spur Gear Attachment (1SD) Parts List	21

1 Introduction

1.1 Purpose

The installation, operation, and maintenance manual (IOM) explains how to install, operate, and maintain the Flowserve Limitorque V gearbox. Information on installation, disassembly, reassembly, lubrication and product weights is provided.

1.2 User Safety

Safety notices in this manual detail precautions the user must take to reduce the risk of personal injury and damage to the equipment. The user must read and be familiar with these instructions before attempting installation, operation or maintenance. Failure to observe these precautions could result in serious bodily injury, damage to the equipment, voiding of the warranty, or operational difficulty.

Safety notices are presented in this manual in three forms:

 **WARNING:** Refers to personal safety. Alerts the user to potential danger. Failure to follow warning notices could result in personal injury or death.

 **CAUTION:** Directs the user's attention to general precautions that, if not followed, could result in personal injury and/or equipment damage.

NOTE: Highlights information critical to the user's understanding of the V gearbox's installation and operation.

2

Inspection, Installation and Mounting Procedures

Figure 2.1 - V Exploded View

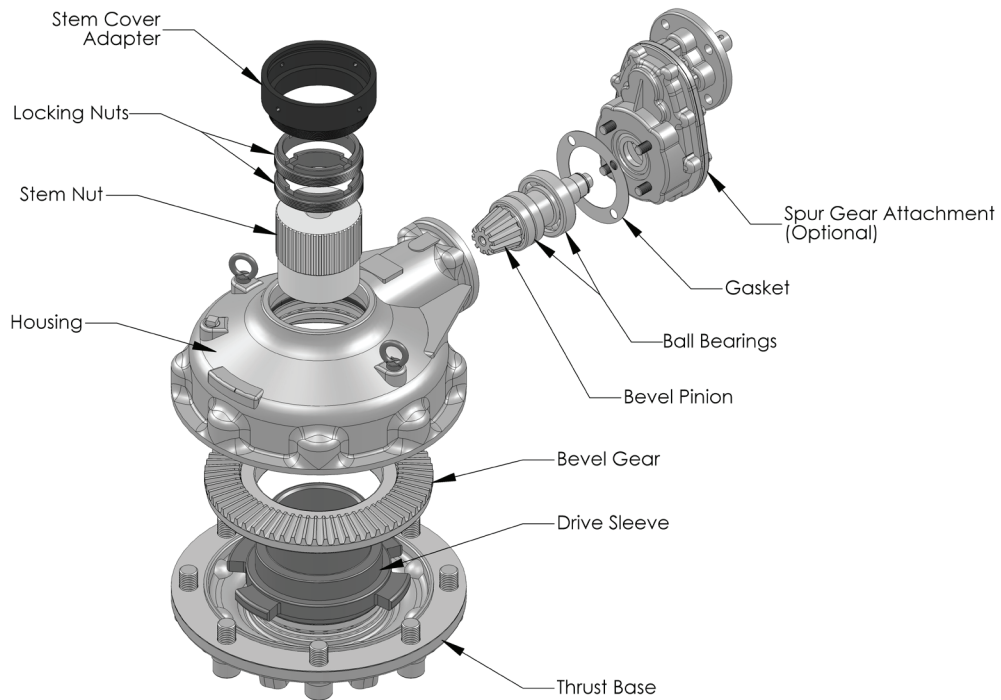

WARNING: Do not manually operate the V gearbox with devices other than the installed handwheel or wrench nut. Using additive force devices (cheater bars, wheel wrenches, pipe wrenches, or other devices of this nature) on the gearbox handwheel, wrench or wrench nut may cause serious personal injury and/or damage to the gearbox or valve.

Figure 2.2 - VH Exploded View

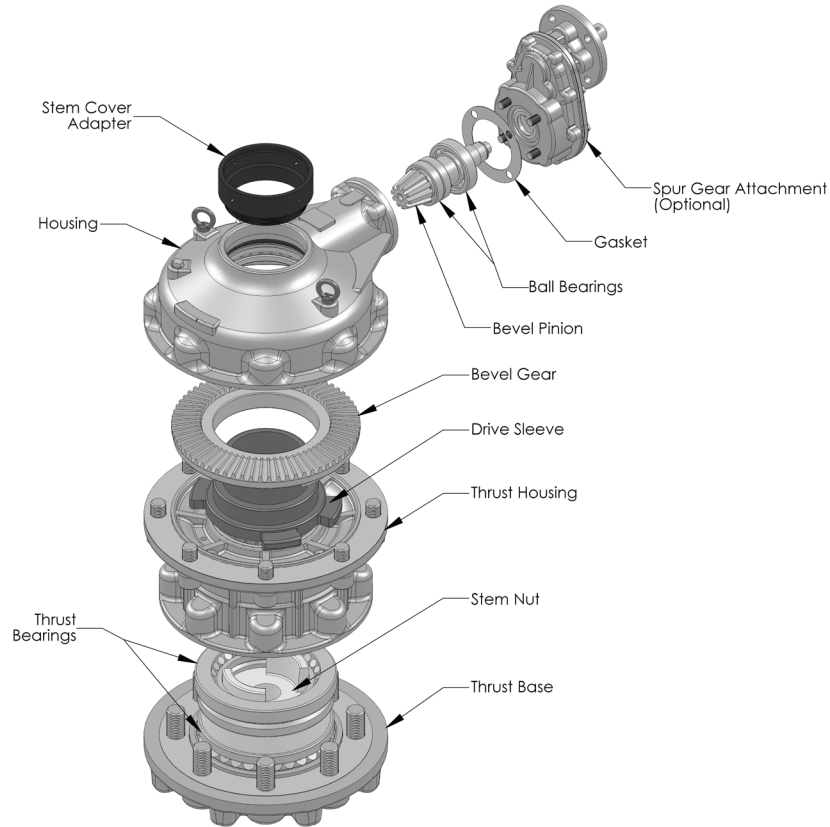

2.1 Initial Inspection and Storage Instructions

⚠ WARNING: Read this installation and maintenance manual carefully and completely before attempting to store the gearbox. If an electric actuator is attached to the V gearbox, be aware of the electrical hazards. Consult the electric actuator installation and maintenance manual for guidance.

2.2 Inspection and Recording

Upon receipt of the gearbox, inspect the condition of the equipment, and record nameplate information.

1. Carefully remove the gearbox from the shipping carton or skid. Thoroughly examine the equipment for any physical damage that may have occurred during shipment. If damaged, immediately report the damage to the transport company.
2. A nameplate is attached to each gearbox with the following information:
 - Gearbox size
 - Order number
 - Serial number
 - Customer tagging

6 Record this information for future reference, e.g., ordering parts, or obtaining further information.









2.3 Storage Procedure

NOTE: The following is the recommended storage procedure to retain maximum product integrity during storage. Failure to comply with recommended procedure will void the warranty.

Storage (less than one year)

Store the gearboxes on wooden skids to protect the machined mounting flange. Place the wooden skids containing the gearboxes in a clean, dry, protected warehouse. If the gearboxes must be stored outside, they must be covered in polyethylene protection with silica gel crystals to absorb moisture. If an electric actuator is attached to the V gearbox, refer to the storage procedures in its respective manual for appropriate storage procedures. Rotate input shafts every three months to mix the lubricant.

2.4 Safety Precautions

-  **WARNING:** Read this Installation, Operation and Maintenance manual carefully and completely before attempting to install, operate or trouble-shoot the Limitorque gearbox.
-  **WARNING:** Potential HIGH-PRESSURE vessel — be aware of high-pressure hazards associated with the attached valve or other actuated device when installing or performing maintenance on the gearbox. Do not remove the gearbox mounting bolts from the valve or actuated device unless the valve or device stem is secured or there is no pressure in the line.
-  **WARNING:** For maintenance and/or disassembly of the gearbox while installed on the valve, ensure that the gearbox is not under thrust or torque load. If the valve must be left in service, the valve stem must be locked in such a way as to prevent any movement of the valve stem.
-  **WARNING:** Do not manually operate the gearbox with devices other than the installed handwheel. Using force beyond the ratings of the gearbox and/or using additive force devices such as cheater bars, wheel wrenches, pipe wrenches, or other devices on the gearbox handwheel may cause serious personal injury and/or damage to the gearbox and valve.
-  **WARNING:** Do not exceed any design limitations or make modifications to this equipment without first consulting Flowserve Limitorque.
-  **WARNING:** Use of this product must be suspended any time it fails to operate properly.
-  **CAUTION:** If a motor actuator is driving the gearbox, do not operate the valve under motor operation without first checking and setting the limit switch and checking for correct motor rotation.
-  **CAUTION:** Do not use replacement parts that are not genuine Flowserve Limitorque parts, as serious personal injury and/or damage to the gearbox and valve may result.

2.5 Safety Practices

The following checkpoints should be performed to maintain safe operation of the V gearbox:

- Set up a periodic operating schedule on infrequently used valves.
- Ensure that the limit and/or torque switches on any electric actuator fitted to the V gearbox are correctly and appropriately adjusted.

2.6 General Mounting Instructions

The mounting instructions for the V bevel gearboxes are outlined below. The V0 through V9 gearboxes are designed with a splined top-entry Stem Nut which is retained in the Drive Sleeve by two Lock Nuts.

The V35H through V9H gearboxes are designed with a Stem Nut which is retained by two Thrust Roller Bearings within the Thrust Housing and Thrust Base. Partial disassembly of the Thrust Base is required for Stem Nut removal and/or installation.

2.6.1 Installing a Gearbox with a Threaded Stem Nut – V0 through V9 and V35H through V9H

1. Position the gearbox above the valve stem.
2. Rotate the gearbox handwheel or wrench nut several turns until there is positive engagement between the valve stem and the gearbox Stem Nut.
3. Rotate the handwheel to lower the gearbox onto the valve until contact has been made with the valve flange.
4. Bolt the gearbox securely to the valve mounting flange.

2.6.2 Installing a Gearbox with a Blank Stem Nut – V0 through V9

1. Remove the two threaded Lock Nuts (pc# 7) from the Drive Sleeve (pc# 6), accessed through the top of the Housing (pc# 1).
2. Remove the Stem Nut (pc# 5) from the Drive Sleeve (pc# 6) through the top of the Housing (pc# 1).
3. Machine the Stem Nut (pc# 5) to suit the valve stem.
- ▲ **CAUTION:** Care must be taken to ensure that the clamping devices used during machining do not damage splined surfaces of the Stem Nut.
4. Reinstall the Stem Nut (pc# 5) into the Drive Sleeve (pc# 6), ensuring the splines are properly engaged.
5. Reinstall the two threaded Lock Nuts (pc# 7) into the Drive Sleeve (pc# 6).
6. Mount the gearbox on the valve as detailed in Section 2.6.1 Installing a Gearbox with a Threaded Stem Nut.

2.6.3 Installing a Gearbox with a Blank Stem Nut – V35H through V9H

1. Place the gearbox upside down to access the mounting base.
2. Remove the Socket Head Cap Screws (pc# 34) which mount the Thrust Base (pc# 31) to the Thrust Housing (pc# 2).
3. Remove the Thrust Base (pc# 31) and Gasket (pc# 32) from the Thrust Housing (pc# 2).
- ▲ **CAUTION:** Care must be taken to ensure that the O-ring (pc# 15) located in the Thrust Base (pc# 31) is not damaged during disassembly.
4. Remove the Stem Nut (pc# 5) and lower Thrust Roller Bearing (pc# 33).
5. Remove the upper Thrust Roller Bearing (pc# 33). Place all bearings in a clean, dry area until reassembly.
6. Machine the Stem Nut (pc# 5) to suit the valve stem.
- ▲ **CAUTION:** Care must be taken to ensure that the clamping devices used during machining do not damage splined surfaces of the Stem Nut (pc# 5).
7. Reinstall the upper Thrust Roller Bearing (pc# 33) into the Thrust Housing (pc# 2).
8. Install the Stem Nut (pc# 5) into the Thrust Housing (pc# 2) and upper Thrust Roller Bearing (pc# 33).
9. Install the lower Thrust Roller Bearing (pc# 33) onto the Stem Nut (pc# 5).
10. Place the Gasket (pc# 32) onto the Thrust Housing (pc# 2).
11. Separately, install the O-Ring (pc# 15) in the Thrust Base (pc# 31).

12. Install the Thrust Base (pc# 31) with O-Ring (pc# 15) onto the Thrust Housing (pc# 2) and Stem Nut (pc# 5), using Socket Head Cap Screws (pc# 34).

▲ CAUTION: Care must be taken to ensure that the O-ring (pc# 15) located in the Thrust Base (pc# 31) is not damaged during installation.

13. Mount the gearbox on the valve as detailed in Section 2.6.1 Installing a Gearbox with a Threaded Stem Nut.

2.7 Stem Cover Mounting Instructions

The gearbox is supplied with a Stem Cover Adapter (pc# 28) which accepts unthreaded Stem Covers of standard NPS pipe sizes. Optionally, the adapter may be removed to access PF (BSPP) pipe threads, if required.

2.7.1 Installing an unthreaded Stem Cover using the supplied Stem Cover Adapter

▲ CAUTION: Care must be taken to ensure the Stem Cover does not damage the O-ring during installation.

NOTE: Lubricate the O-ring (pc# 27) before installing the Stem Cover.

1. Loosen the (4) set screws (pc# 30) in the Stem Cover Adapter (pc# 28).
2. Install the Stem Cover into the Stem Cover Adapter (pc# 28) and secure using the quantity (4) set screws.

2.7.2 Installing a threaded Stem Cover using the optional PF (BSPP) pipe threads

▲ CAUTION: Care must be taken during installation to prevent damage to the Stem Cover and Housing threads.

NOTE: Apply thread sealant to external threads on Stem Cover before installing.

1. Loosen the set screw (pc# 20) in the Housing (pc# 1).
2. Remove the Stem Cover Adapter (pc# 28) with O-ring (pc# 27) by unthreading it from the Housing (pc# 1).
3. Remove and discard the O-ring (pc# 26).
4. Install the threaded Stem Cover into the Housing (pc# 1) and tighten.

3 Lubrication

Flowserve Limatorque V gearboxes are shipped with the following lubricants:

Table 3.1 – Lubricants

Product	Lubricant	Soap Base	Temperature Range
V0 through V9	Zenith LH2	Calcium	-35°C to 90°C (-31°F to 194°F)
V35H through V9H	Zenith LH2	Calcium	--35°C to 90°C (-31°F to 194°F)

NOTE: The lubricant should be checked every 18 months for gearboxes.

⚠ CAUTION: Do not add a different lubricant to a Flowserve Limatorque gearbox unless it is of the same soap base as the existing lubricant, or you have received the approval of the existing lubricant’s manufacturer.

Quantity

Limatorque V gearboxes are lubricated so that all bearings and gearing/gear contact areas are liberally coated with grease. The gearboxes do not require additional lubricant under normal operating conditions.

Quality

Remove a small amount of lubricant and inspect for any contaminant, including water. Should dirt, water, or other foreign matter be found, the lubricant must be replaced. Partial disassembly of the gearbox will be required. Contact Flowserve Limatorque with the gearbox order number or serial number for replacements parts, if required.

Consistency

The main gearbox lubricant should be slightly fluid, approximating a standard NLGI-2 grade consistency or less.

Alternate lubricants may be used in place of the standard lubricants supplied by Flowserve, provided they are of a formulation similar to those listed above for the respective product. Contact Flowserve Limatorque if you have questions about an alternate lubricant.

4 Product Weights

Table 4.1 - V Gearbox Weights

	V Gearbox Weights					
	Basic Gearbox		With Single Reduction Spur Set		With Double Reduction Spur Set	
	Lbs	Kg	Lbs	Kg	Lbs	Kg
V0	35	16	55	25	57	26
V1	49	22	71	32	73	33
V2	75	34	99	45	108	49
V3	99	45	126	57	134	61
V35	172	78	209	95	225	102
V4	227	103	265	120	280	127
V5	339	154	366	166	374	170
V55	430	195	459	208	467	212
V6	522	237	578	262	611	277
V7	705	320	761	345	794	360
V75	1,021	463	1,153	523	1,226	556
V8	1,020	463	1,178	535	1,240	563
V9	1,622	736	1,711	776	1,742	790

Table 4.2 - VH Gearbox Weights

	VH Gearbox Weights					
	Basic Gearbox		With Single Reduction Spur Set		With Double Reduction Spur Set	
	Lbs	Kg	Lbs	Kg	Lbs	Kg
V35H	348	158	375	170	384	174
V4H	441	200	467	212	476	216
V5H	582	264	608	276	617	280
V55H	860	390	888	403	897	407
V6H	1,157	525	1,219	553	1,248	566
V7H	1,312	595	1,373	623	1,402	636
V75H	1,907	865	2,066	937	2,127	965
V8H	2,105	955	2,264	1,027	2,326	1,055
V9H	3,962	1,797	4,176	1,894	4,259	1,932

5

Disassembly and Reassembly Instructions

⚠ WARNING: See Section 2.4 Safety Precautions and 2.5 Safety Practices before undertaking the steps below.

5.1 Disassembly and Reassembly of V0 through V9

Disassembly Instructions

Refer to Figure 5.1

1. Remove the two threaded Lock Nuts (pc# 7) from the Drive Sleeve (pc# 6), accessed through the top of the Housing (pc# 1).
2. Remove the Stem Nut (pc# 5) from the Drive Sleeve through the top of the Housing (pc# 1).
3. Remove the Stem Cover Adapter (pc# 28) and O-Rings (pc# 26 and pc# 27).
4. Remove the Input Flange (pc# 8) with Oil Seal (pc# 25) and Gasket (pc# 21), or remove the Spur Gear Attachment (See Section 5.3 or 5.4).
5. Remove the Bevel Pinion subassembly from the Housing (pc# 1).
6. Separately, for V0 – V4, remove the Retaining Ring (pc# 29), or, for V5 – V9, remove the Bearing Washer (pc# 18) and Bearing Nut (pc# 17).
7. Remove Collar (pc# 16) and Bearings (pc# 11 and pc# 12) from the Bevel Pinion (pc# 4).
8. Place the gearbox upside down to access the mounting base.
9. Remove the Thrust Base (pc# 2) with O-Ring (pc# 15) and Gasket (pc# 22) by removing Socket Head Cap Screws (pc# 9).
10. Remove the lower Thrust Ball Bearing (pc# 13).
11. Remove the assembled Drive Sleeve (pc# 6) and Bevel Gear (pc# 3).

12. Separately, remove the Bevel Gear (pc# 3) from the Drive Sleeve (pc# 6).
13. Remove the upper Thrust Ball Bearing (pc# 13) from the Housing (pc# 1).
14. Remove the O-Ring (pc# 15) from the Housing (pc# 1).

Reassembly Instructions

Refer to Figure 5.1

1. Place the Housing (pc# 1) upside down for internal access.
2. Install the O-Ring (pc# 15) in the Housing (pc# 1).

NOTE: Lubricate all O-Rings before installation

3. Install the upper Thrust Bearing (pc# 13) in the Housing (pc# 1).
4. Separately, install the Bevel Gear (pc# 3) onto the Drive Sleeve (pc# 6), engaging the Bevel Gear and Drive Sleeve lugs.
5. Install the assembled Bevel Gear (pc# 3) and Drive Sleeve (pc# 6) into the Housing (pc# 1) and Thrust Bearing (pc# 13).
6. Install the lower Thrust Bearing (pc# 13) onto the Drive Sleeve (pc# 6).
7. Place the Gasket (pc# 22) onto the Housing (pc# 1).
8. Separately, install the O-Ring (pc# 15) in the Thrust Base (pc# 2).

NOTE: Lubricate all O-Rings before installation

9. Install the Thrust Base (pc# 2) with O-Ring (pc# 15) onto the Housing (pc# 1) and Drive Sleeve (pc# 6) using Socket Head Cap Screws (pc# 9).

▲ CAUTION: Care must be taken to ensure that the O-ring located in the Thrust Base is not damaged during installation.

10. Place the gearbox in the upright position.
11. Install the Stem Cover Adapter (pc# 28) and O-Rings (pc# 26 and pc# 27) on the Housing (pc# 1).
12. Separately, install the Bearings (pc# 11), Collar (pc# 16), Bearing (pc# 12), and additionally for V0–V4 only, the Retaining Ring (pc# 29). For V5–V9, install the Bearing Washer (pc# 18) and Bearing Nut (pc# 17) onto the Bevel Pinion (pc# 4).
13. Install the Bevel Pinion subassembly into the Housing (pc# 1).
14. Replace the Oil Seal (pc# 25) in the Input Flange (pc# 8), if required.
15. Place the Gasket (pc# 21) onto the Housing (pc# 1) and install the Input Flange (pc# 8) or the Spur Gear Attachment (See Section 5.3 or 5.4).

▲ CAUTION: For proper backlash of the bevel gear set, ensure supplied gaskets and shims (if applicable) are placed between the Input Flange (or Spur Gear Attachment) and Housing.

NOTE: Ensure binding does not occur between the Bevel Pinion and Bevel Gear

NOTE: Lubricate all Oil Seals before installation

Figure 5.1 - V0 - V9 Assembly View

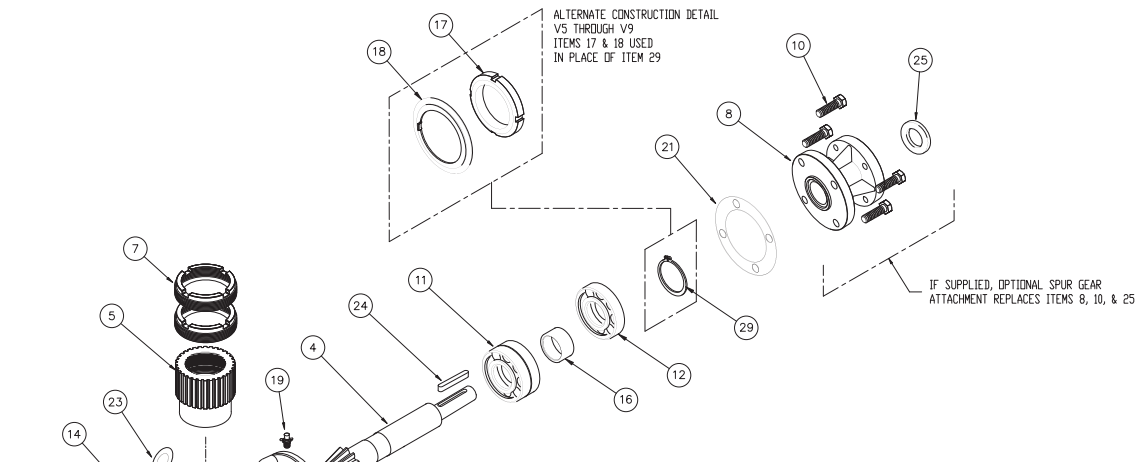
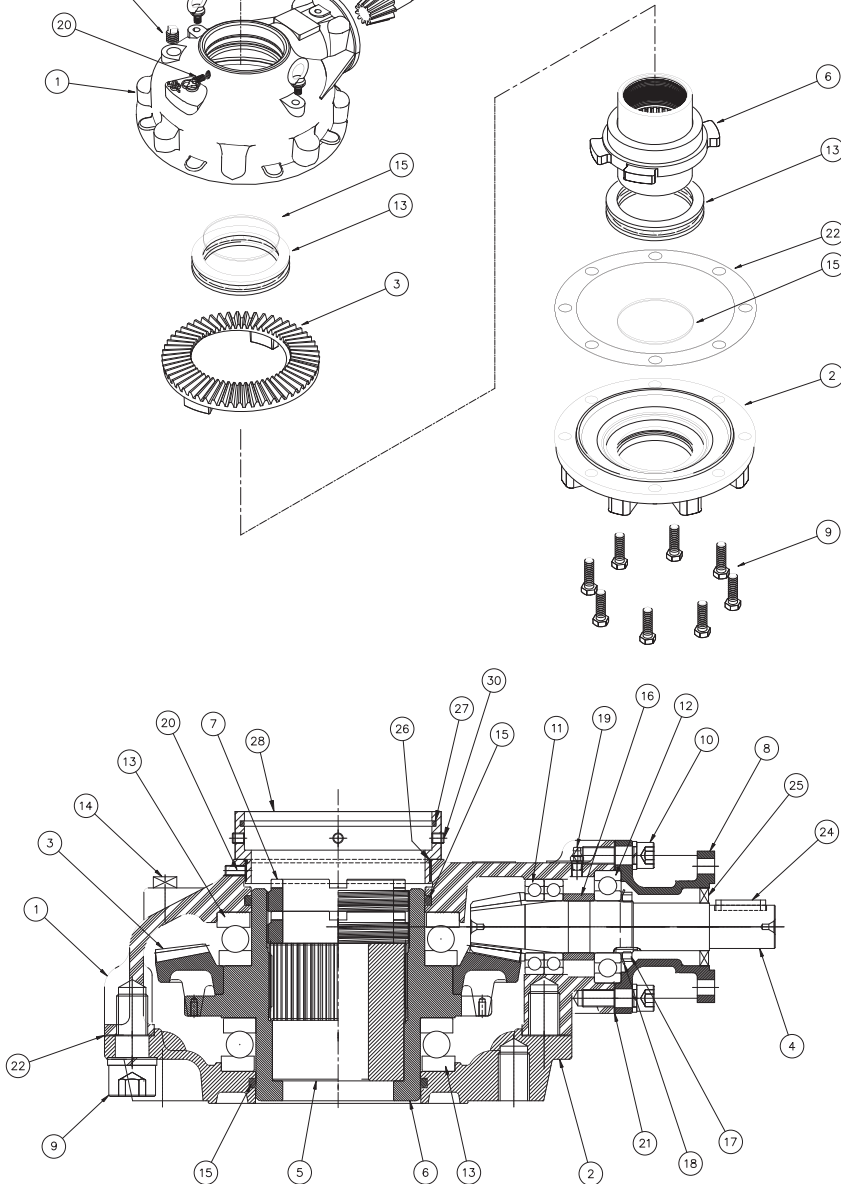

Table 5.1 - V0 Through V9 Parts List

Item No.	Description	QTY
1	Housing	1
2	Thrust Base	1
3	Bevel Gear	1
4	Bevel Pinion	1
5	Stem nut	1
6	Drive Sleeve	1
7	Lock Nut	2
8	Input Flange	1
9	Socket Head Cap Screw	8
10	Socket Head Cap Screw	4
11	Ball Bearing	2
12	Ball Bearing	1
13	Thrust Bearing	2
14	Pipe Plug	1
15	O-Ring	2
18	Collar	1
17	Bearing But	Varies
18	Bearing Washer	Varies
19	Grease Fitting	1
20	Set Screw	1
21	End Cap Gasket	1
22	Base Gasket	1
23	Eye Bolt	2
24	Key	1
25	Oil Seal	1
26	O-Ring	1
27	O-Ring	1
28	Stem Cover Adapter	1
29	Retaining Ring	Varies
30	Set Screw	4



5.2 Disassembly and Reassembly of V35H through V9H

Disassembly Instructions

Refer to Figure 5.2

1. Remove the Stem Cover Adapter (pc# 28) and O-Rings (pc# 26 and pc# 27).
2. Remove the Input Flange (pc# 8) with Oil Seal (pc# 25) and Gasket (pc# 21), or remove the Spur Gear Attachment (See Section 5.3 or 5.4).
3. Remove the Bevel Pinion subassembly from the Housing (pc# 1).
4. Separately, for V35H and V4H, remove the Retaining Ring (pc# 29), or for V5H–V9H, remove the Bearing Washer (pc# 18) and Bearing Nut (pc# 17).
5. Remove Collar (pc# 16) and Bearings (pc# 11 and pc# 12) from the Bevel Pinion (pc# 4).
6. Place the gearbox upside down to access the mounting base.
7. Remove the Socket Head Cap Screws (pc# 34), Thrust Base (pc# 31) and Gasket (pc# 32) from the Thrust Housing (pc# 2).
8. Remove the Stem Nut (pc# 5) with upper and lower Thrust Roller Bearings (pc# 33).
9. Remove the Thrust Housing (pc# 2) with O-Ring (pc# 15) and Gasket (pc# 22) by removing Socket Head Cap Screws (pc# 9).
10. Remove the lower Thrust Ball Bearing (pc# 13-B).
11. Remove the assembled Drive Sleeve (pc# 6) and Bevel Gear (pc# 3).
12. Separately, remove the Bevel Gear (pc# 3) from the Drive Sleeve (pc# 6).
13. Remove the upper Thrust Ball Bearing (pc# 13-A) from the Housing (pc# 1).
14. Remove the O-Ring (pc# 15) from the Housing (pc# 1).

Reassembly Instructions

Refer to Figure 5.2

1. Place the Housing (pc# 1) upside down for internal access.
2. Install the O-Ring (pc# 15) in the Housing (pc# 1).

NOTE: Lubricate all O-Rings before installation

3. Install the upper Thrust Ball Bearing (pc# 13-A) in the Housing (pc# 1).
4. Separately, install the Bevel Gear (pc# 3) onto the Drive Sleeve (pc# 6), engaging the Bevel Gear and Drive Sleeve lugs.
5. Install the assembled Bevel Gear (pc# 3) and Drive Sleeve (pc# 6) into the Housing (pc# 1) and upper Thrust Ball Bearing (pc# 13-A).
6. Install the lower Thrust Ball Bearing (pc# 13-B) onto the Drive Sleeve (pc# 6).
7. Place the Gasket (pc# 22) onto the Housing (pc# 1).
8. Separately, install the O-Ring (pc# 15) in the Thrust Housing (pc# 2).

NOTE: Lubricate all O-Rings before installation

9. Install the Thrust Housing (pc# 2) with O-Ring (pc# 15) onto the Housing (pc# 1) and Drive Sleeve (pc# 6) using Socket Head Cap Screws (pc# 9).

▲ CAUTION: Care must be taken to ensure that the O-ring located in the Thrust Base is not damaged during installation.

10. Install the upper Thrust Roller Bearing (pc# 33) into the Thrust Housing (pc# 2).

11. Install the Stem Nut (pc# 5) into the Thrust Housing (pc# 2) and upper Thrust Roller Bearing (pc# 33).

12. Install the lower Thrust Roller Bearing (pc# 33) onto the Stem Nut (pc# 5).

13. Place the Gasket (pc# 32) onto the Thrust Housing (pc# 2).

14. Separately, install the O-Ring (pc# 15) into the Thrust Base (pc# 31).

15. Install the Thrust Base (pc# 31) with O-Ring (pc# 15) onto the Thrust Housing (pc# 2) and Stem Nut (pc# 5) using Socket Head Cap Screws (pc# 34).

▲ CAUTION: Care must be taken to ensure that the O-ring located in the Thrust Base is not damaged during installation.

16. Place the gearbox in the upright position.

17. Install the Stem Cover Adapter (pc# 28) and O-Rings (pc# 26 and pc# 27) on the Housing (pc# 1).

18. Separately, install the Bearings (pc# 11), Collar (pc# 16), Bearing (pc# 12), and additionally for V35H and V4H only, the Retaining Ring (pc# 29). For V5H–V9H, install the Bearing Washer (pc# 18) and Bearing Nut (pc# 17) onto the Bevel Pinion (pc# 4).

19. Install the Bevel Pinion subassembly into the Housing (pc# 1).

20. Replace the Oil Seal (pc# 25) in the Input Flange (pc# 8), if required.

21. Place the Gasket (pc# 21) onto the Housing (pc# 1) and install the Input Flange (pc# 8) or the Spur Gear Attachment (See Section 5.3 or 5.4).

▲ CAUTION: For proper backlash of the bevel gear set, ensure supplied gaskets and shims (if applicable) are placed between the Input Flange (or Spur Gear Attachment) and Housing.

NOTE: Ensure binding does not occur between the Bevel Pinion and Bevel Gear

NOTE: Lubricate all Oil Seals before installation

Figure 5.2 - V35H – V9H Assembly View

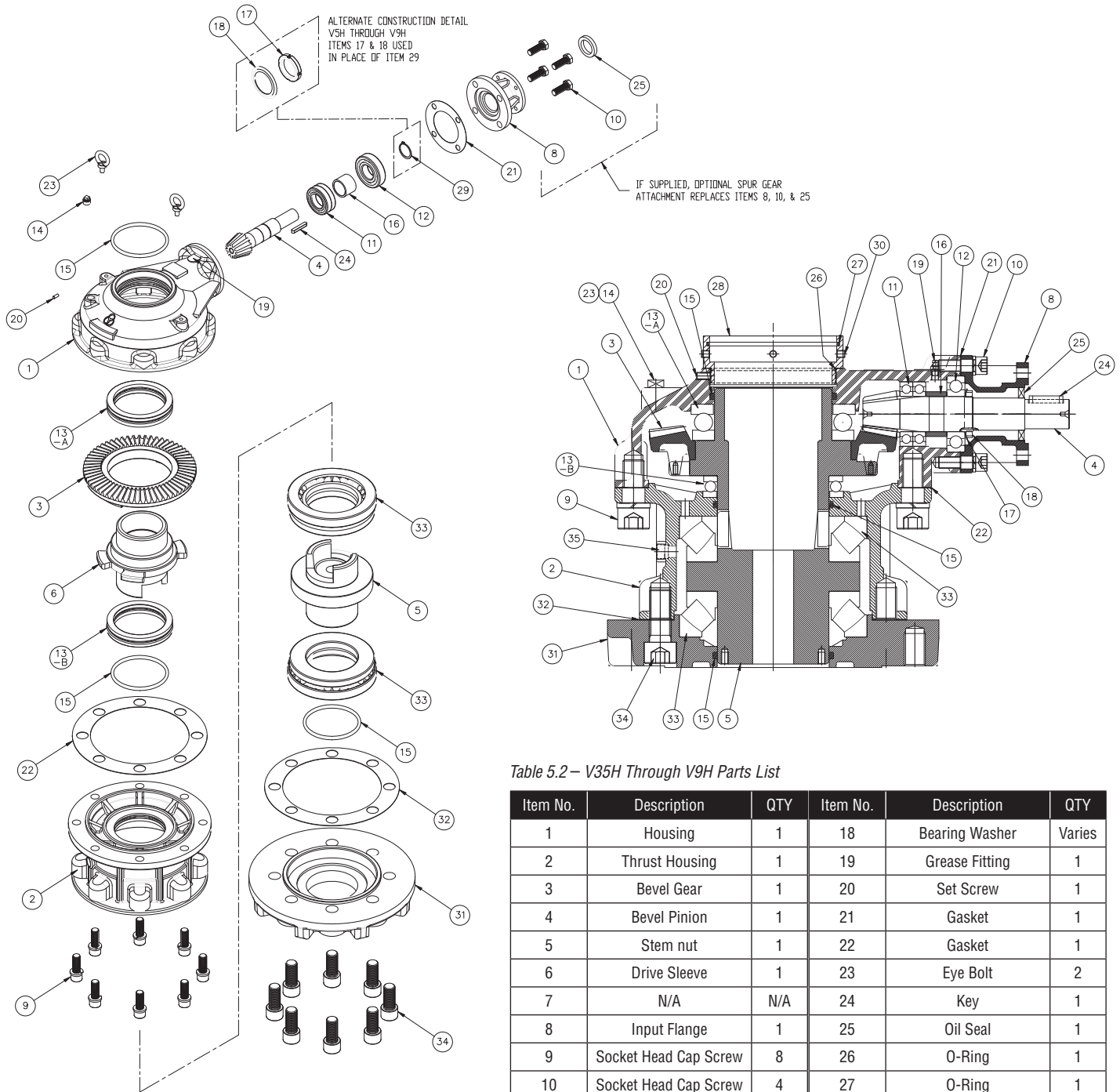

Table 5.2 – V35H Through V9H Parts List

Item No.	Description	QTY	Item No.	Description	QTY
1	Housing	1	18	Bearing Washer	Varies
2	Thrust Housing	1	19	Grease Fitting	1
3	Bevel Gear	1	20	Set Screw	1
4	Bevel Pinion	1	21	Gasket	1
5	Stem nut	1	22	Gasket	1
6	Drive Sleeve	1	23	Eye Bolt	2
7	N/A	N/A	24	Key	1
8	Input Flange	1	25	Oil Seal	1
9	Socket Head Cap Screw	8	26	O-Ring	1
10	Socket Head Cap Screw	4	27	O-Ring	1
11	Ball Bearing	2	28	Steam Cover Adapter	1
12	Ball Bearing	1	29	Retaining Ring	Varies
13-A	Thrust Ball Bearing	1	30	Set Screw	4
13-B	Thrust Ball Bearing	1	31	Thrust Base	1
14	Pipe Plug	1	32	Gasket	1
15	O-Ring	3	33	Thrust Roller Bearing	2
16	Collar	1	34	Socket Head Cap Screw	8
17	Bearing Nut	Varies	35	Pipe Plug	1

5.3 Disassembly and Reassembly of Single Reduction Spur Gear Attachment (1S)

Disassembly Instructions

Refer to Figure 5.3

1. Remove the Cap Screws (pc# 17) and Input Flange (pc# 15) with Oil Seal (pc# 16) from the Cover (pc# 5).
2. Remove the Hex Head Cap Screws (pc# 13) and Cover (pc# 5) with Oil Seal (pc# 14).
3. Remove all traces of the Cover Gasket (pc# 12).
4. Remove the Input Shaft/Pinion (pc# 4) and Ball Bearings (pc# 10) from the Cover (pc# 5).
5. Remove the Ball Bearing (pc# 7) and Retaining Ring (pc# 6) from the gearbox Bevel Pinion.
6. Remove the Gear (pc# 2) and Keys (pc# 11) from the gearbox Bevel Pinion.
7. Remove the two Idler Gears (pc# 3) and Bearings (pc# 8).
8. Remove the Cap Screws (pc# 19) which mount the Spur Gear Attachment to the gearbox and remove the Spur Gear Housing (pc# 1).
9. If disassembly of the bevel gearbox is required, see Sections 5.1 or 5.2.

Reassembly Instructions

Refer to Figure 5.3

1. Install the Spur Gear Housing (pc# 1) on the bevel gearbox, ensuring proper gasket is installed between the gearbox and spur gear housing (see Section 5.3 or 5.4)
2. Install the Gear (pc# 2) onto the gearbox Bevel Pinion with Keys (pc# 11). Fasten with Retaining Ring (pc# 6).
3. Install the Ball Bearing (pc# 7) onto the gearbox Bevel Pinion.
4. Install the Ball Bearings (pc# 8) and (pc# 9) into the Spur Gear Housing (pc# 1).
5. Install the Idler Gears (pc# 3).
6. Install the Input Shaft/Pinion (pc# 4).
7. Install the Ball Bearings (pc# 8) on the Idler Gears (pc# 3).
8. Install the Ball Bearings (pc# 10) on the Input Shaft/Pinion (pc# 4).
9. Replace the Cover Gasket (pc# 12).
10. Replace the Oil Seal (pc# 14) in the Cover (pc# 5).

NOTE: Lubricate the Spur Gearing. See Section 3.

11. Install the Cover (pc# 5), mounting with Hex Head Cap Screws (pc# 13).
12. Install the Input Flange (pc# 15) with Oil Seal (pc# 16) onto the Cover (pc# 5) using Cap Screws (pc# 17).

NOTE: Replace any worn or damaged O-Rings or gaskets to ensure proper sealing and operation.

Figure 5.3 - V0 – V9, and V35H – V9H Spur Gear Attachment (1S) Exploded View

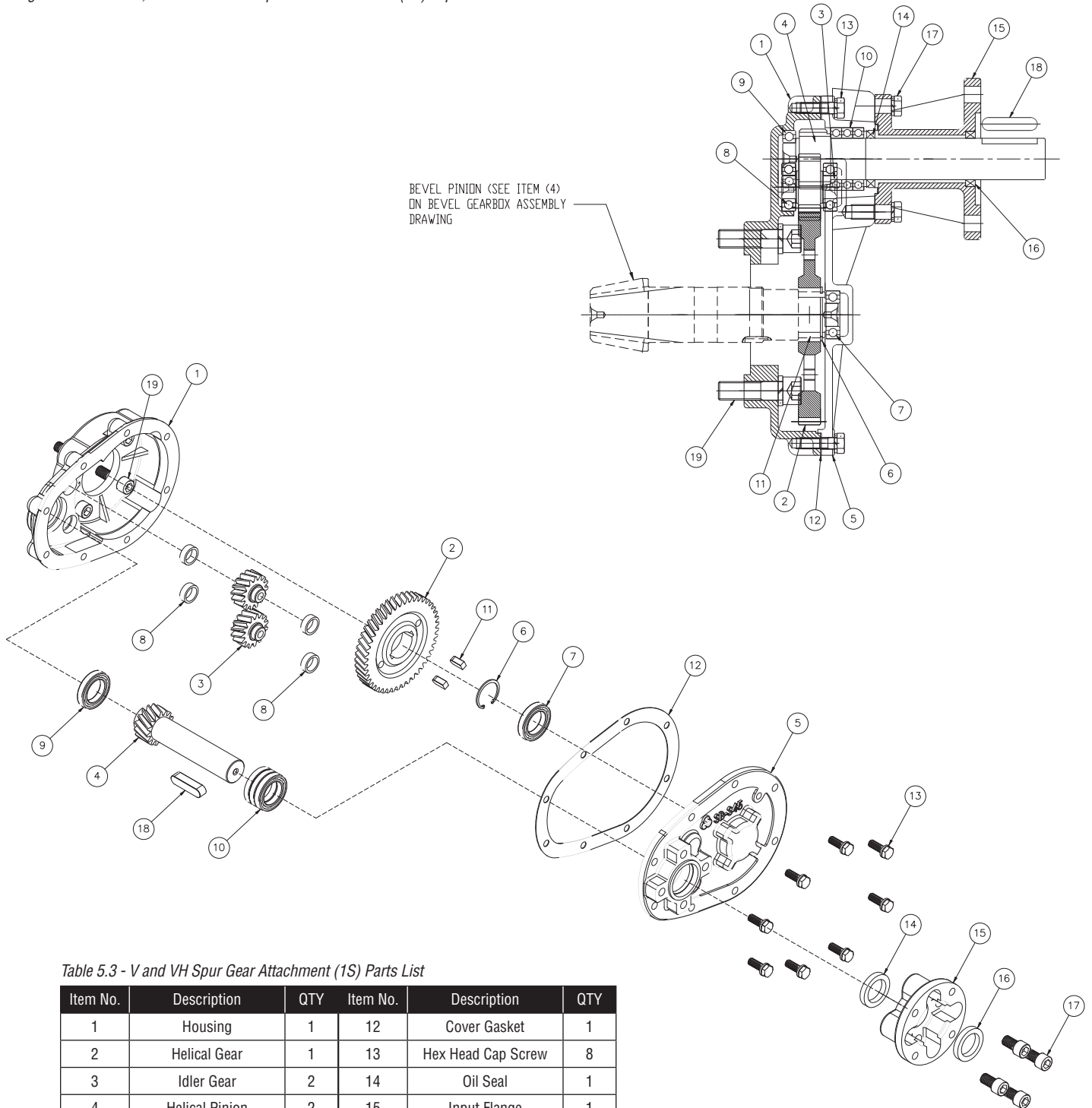

Table 5.3 - V and VH Spur Gear Attachment (1S) Parts List

Item No.	Description	QTY	Item No.	Description	QTY
1	Housing	1	12	Cover Gasket	1
2	Helical Gear	1	13	Hex Head Cap Screw	8
3	Idler Gear	2	14	Oil Seal	1
4	Helical Pinion	2	15	Input Flange	1
5	Cover	1	18	Oil Seal	1
6	Retaining Ring	1	17	Cap Screw	Varies
7	Ball Bearing	1	18	Key	1
8	Ball Bearing	4	19	Cap Screw	Varies
9	Ball Bearing	1			
10	Ball Bearing	3			
11	Key	2			

5.4 Disassembly and Reassembly of Double Reduction Spur Gear Attachment (1SD)

Disassembly Instructions

Refer to Figure 5.4

1. Remove the Cap Screws (pc# 19) and Input Flange (pc# 18) with Oil Seal (pc# 15) from the Cover (pc# 12).
2. Remove the Hex Head Cap Screws (pc# 14) and Cover (pc# 12) with Oil Seal (pc# 15).
3. Remove the Helical Gear/2nd Set Pinion subassembly.
4. Remove all traces of the Cover Gasket (pc# 13).
5. Remove the Input Shaft/Pinion subassembly from the Cover (pc# 12) by removing the Retaining Ring (pc# 16).
6. Separately, remove the Retaining Ring (pc# 4) and Ball Bearings (pc# 11) from the Input Shaft/Pinion (pc# 9).
7. Remove the Ball Bearing (pc# 8) from the 2nd Set Pinion (pc# 5).
8. Remove the Retaining Ring (pc# 4) and the Helical Gear (pc# 2) from the 2nd Set Pinion (pc# 5).
9. Remove the Retaining Ring (pc# 4) and the Helical Gear (pc# 2) from the gearbox Bevel Pinion.
10. Remove the Cap Screws (pc# 20) which mount the Spur Gear Attachment to the gearbox and remove the Spur Gear Housing (pc# 1).
11. If disassembly of the bevel gearbox is required, see Sections 5.1 or 5.2

Reassembly Instructions

Refer to Figure 5.4

1. Install the Spur Gear Housing (pc# 1) on the bevel gearbox, ensuring proper gasket is installed between the gearbox and spur gear housing
2. Install the Helical Gear (pc# 2) on the gearbox Bevel Pinion with Keys (pc# 3). Fasten with Retaining Ring (pc# 4).
3. Insert the Bushing (pc# 10) into the end of the Input Shaft/Pinion (pc# 9).
4. Install the Ball Bearings (pc# 11) and Retaining Ring (pc# 4) onto the Input Shaft/Pinion (pc# 9).
5. Install the Input Shaft/Pinion subassembly in the Cover (pc# 12) using Retaining Ring (pc# 16).
6. Install the Ball Bearing (pc# 6) in the Spur Gear Housing (pc# 1).
7. Assemble the Helical Gear (pc# 2) on the 2nd Set Pinion (pc# 5) with Keys (pc# 7). Fasten with Retaining Ring (pc# 4).
8. Install the Ball Bearing (pc# 8) on the 2nd Set Pinion (pc# 5).
9. Install the Helical Gear/2nd Set Pinion subassembly in the Ball Bearing (pc# 6).

NOTE: Lubricate the Spur Gearing. See Section 3.

10. Replace the Gasket Cover (pc# 13).
11. Install the Cover (pc# 12) with Input Shaft/Pinion subassembly onto the Spur Gear Housing (pc# 1), ensuring proper mesh of Input Shaft/Pinion (pc# 9) and Helical Gear (pc# 2), and alignment of Ball Bearing (pc# 8) with Cover (pc# 12).
12. Replace the Oil Seal (pc# 15) in the Cover (pc# 12).
13. Install the Input Flange (pc# 18) with Oil Seal (pc# 15) onto the Cover (pc# 12) using Cap Screws (pc# 19).

NOTE: Replace any worn or damaged O-Rings or Gaskets to ensure proper sealing and operation.

Figure 5.4 - V0 – V9, and V35H – V9H Spur Gear Attachment (1SD) Exploded View

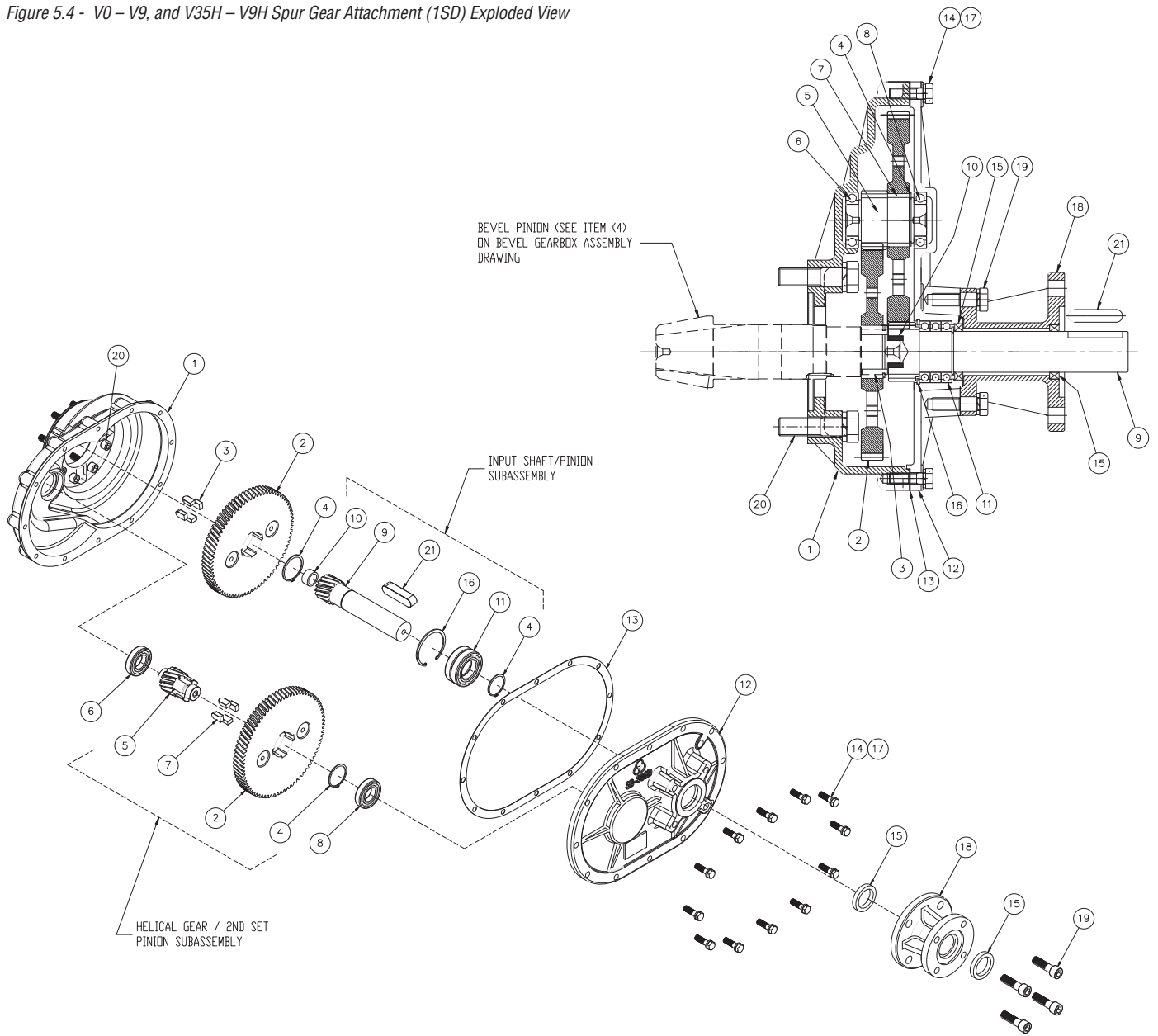

Table 5.4 - V and VH Spur Gear Attachment (1SD) Parts List

Item No.	Description	QTY	Item No.	Description	QTY
1	Housing	1	12	Cover	1
2	Helical Gear	1	13	Cover Gasket	1
3	Key	2	14	Hex Head Cap Screw	10
4	Retaining Ring	3	15	Oil Seal	1
5	2nd Set Pinion	1	18	Retaining Ring	1
6	Ball Bearing	1	17	Lock Washer	10
7	Key	1	18	Input Flange	1
8	Ball Bearing	1	19	Cap Screw	Varies
9	Helical Pinion	1	20	Cap Screw	Varies
10	Oil Seal	1	21	Key	1
11	Ball Bearing	3			

6

How to Order Parts

To order parts or obtain further information for your Limitorque V Series gearbox, contact your local Limitorque distributor sales office, or:

Flowserve Limitorque

5114 Woodall Road
Lynchburg, VA 24502

Telephone 434 528 4400
Fax 434 845 9736
www.limitorque.com

All inquiries or orders must be accompanied by the following information:

1. Gearbox Size
2. Limitorque Order Number
3. Limitorque Serial Number





Flowserve Corporation

United States

Flowserve Limitorque
5114 Woodall Road,
Lynchburg, VA 24502
Phone: 434-528-4400
Fax: 434-845-9736

Singapore

Limitorque Asia, Pte., Ltd.
12, Tuas Avenue 20
Singapore 638824
Phone: 65-6868-4628
Fax: 65-6862-4940

China

Limitorque Beijing, Pte., Ltd.
RM A1/A2
22F, East Area, Hanwei Plaza
No. 7 Guanghai Road, Chaoyang District
Beijing 100004, Peoples Republic of
China
Phone: 86-10-5921-0606
Fax: 86-10-6561-2702

India

Office A, 7th Floor, Plot No 32A & B
Ambit IT Park, Ambit IT Park Road
Ambattur Industrial Estate
Chennai - 600058
Phone: 91-44-2432-8755
& 91-44-2432-4801
Facsimile: 91-44-2432-8754

Italy

Flowserve Limitorque
Via Rio Vallone 17
20883 Mezzago (MB)
Italy
Phone: +39 039 62060 1
Fax: +39 039 62060 213

FCD LMENIM3601-02-AQ 09/17 Printed in USA.

To find your local Flowserve representative, visit www.flowserve.com, www.limitorque.com, or call 1 800 225 6989

Flowserve Corporation has established industry leadership in the design and manufacture of its products. When properly selected, this Flowserve product is designed to perform its intended function safely during its useful life. However, the purchaser or user of Flowserve products should be aware that Flowserve products might be used in numerous applications under a wide variety of industrial service conditions. Although Flowserve can (and often does) provide general guidelines, it cannot provide specific data and warnings for all possible applications. The purchaser/user must therefore assume the ultimate responsibility for the proper sizing and selection, installation, operation, and maintenance of Flowserve products. The purchaser/user should read and understand the Installation Operation Maintenance (IOM) instructions included with the product, and train its employees and contractors in the safe use of Flowserve products in connection with the specific application.

While the information and specifications contained in this literature are believed to be accurate, they are supplied for informative purposes only and should not be considered certified or as a guarantee of satisfactory results by reliance thereon. Nothing contained herein is to be construed as a warranty or guarantee, express or implied, regarding any matter with respect to this product. Because Flowserve is continually improving and upgrading its product design, the specifications, dimensions and information contained herein are subject to change without notice. Should any question arise concerning these provisions, the purchaser/user should contact Flowserve Corporation at any one of its worldwide operations or offices.

© 2015 Flowserve Corporation, Irving, Texas, USA. Flowserve is a registered trademark of Flowserve Corporation.