

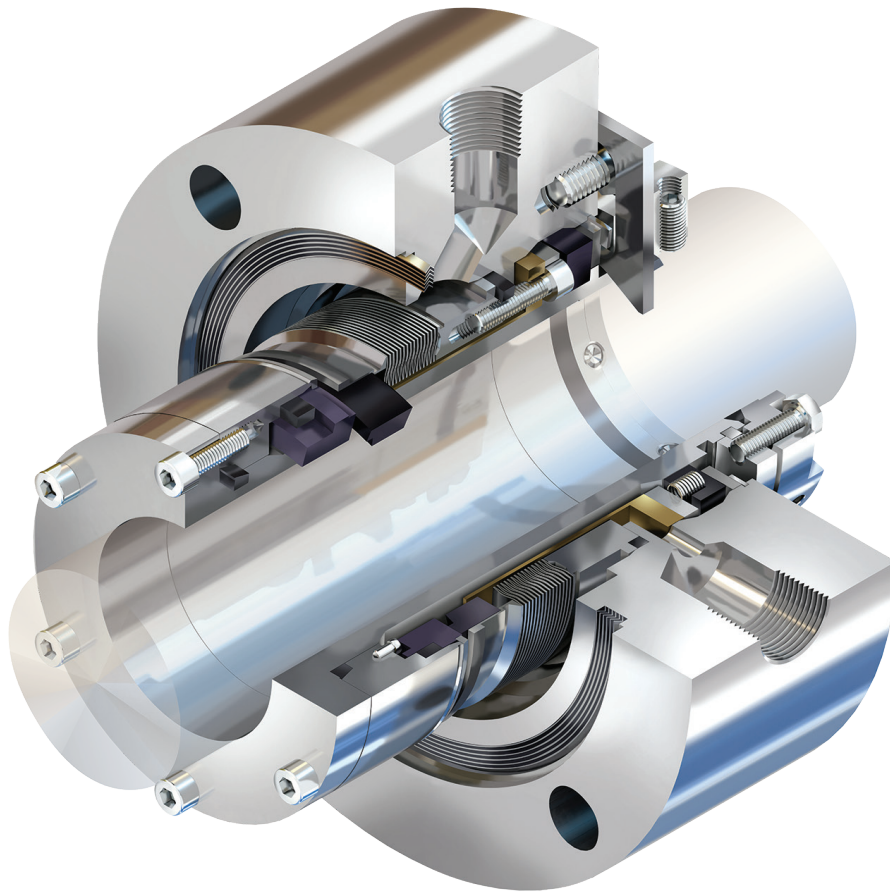

INSTALLATION INSTRUCTIONS

High-Temperature Metal Bellows Seals Cartridge seals with flexible graphite gaskets

BXH, BXHH, BXRH, BXHT, BRC, GTSP, GSDH Series



Contents

1. Equipment check	3
2. Seal installation	4
3. Piping instructions.....	5
4. Performance testing of pumps.....	6
5. Operational recommendations.....	6
6. Repair	7

1. Equipment check

- 1.1 Follow plant safety regulations prior to equipment disassembly:
 - 1.1.1 Wear designated personal safety equipment.
 - 1.1.2 Isolate equipment and relieve any pressure in the system.
 - 1.1.3 Lock out equipment driver and valves.
 - 1.1.4 Consult plant Safety Data Sheet (SDS) files for hazardous material regulations.
- 1.2 Disassemble equipment in accordance with the equipment manufacturer's instructions to allow access to seal installation area.
- 1.3 Remove existing sealing arrangement (mechanical seal or otherwise). Clean seal chamber and shaft thoroughly.
- 1.4 Inspect surfaces under gaskets to ensure they are free from pits or scratches. Break all sharp corners on shaft steps, threads, reliefs, shoulders, key ways, etc. over which gasket(s) must pass and/or seal against.
- 1.5 Check shaft or sleeve OD, seal chamber bore, seal chamber depth, gland pilot, stud diameter, stud bolt pattern and distance to first obstruction to ensure they are dimensionally the same as shown in the seal assembly drawing.
- 1.6 Check seal assembly drawings for any modifications (reworks) to be made to the equipment for mechanical seal installation and act accordingly.
- 1.7 The equipment must be earthed to prevent sparks due to static electricity discharge.

Shaft runout should be checked against the equipment manufacturer's specifications. Generally, should not exceed 0.05 mm (0.002 in) TIR (Total Indicator Reading) at any point along the shaft for ball or roller-type bearings. For sleeve-type bearings, refer to manufacturer instructions. If the equipment is not completely dismantled, verify runout near seal location.

The above values apply to shaft speeds in the range from 1,000 to 3,600 RPM. For values above and below, consult your Flowserve representative. See Figure 1.

Shaft endplay should not exceed 0.25 mm (0.010 in) TIR, regardless of thrust bearing type. See Figure 2.

Maximum dynamic shaft deflection at seal chamber face should be checked against the equipment manufacturer's specifications. Generally 0.05 to 0.10 mm (0.002 to 0.004 in) will be applicable for ball or roller-type bearings. For sleeve or journal-type bearings, values will generally be in the order of 0.10 to 0.15 mm (0.004 to 0.006 in).

Seal chamber squareness to the shaft centerline should be within 0.0005 mm/mm (0.0005 in/in) of seal chamber bore TIR.

Note: make sure that shaft endplay does not affect the reading. Verify the smoothness of the seal chamber face for a good gasket joint. See Figure 3.

Concentricity of the shaft to the seal chamber bore or gland pilot register should be within 0.025 mm per 25 mm shaft diameter (0.001 in per 1 in shaft diameter) to a maximum of 0.125 mm (0.005 in) TIR. See Figure 4.

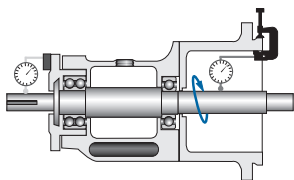

Figure 1

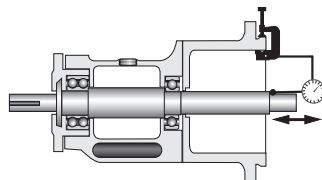

Figure 2

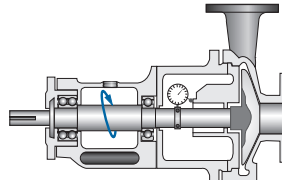

Figure 3

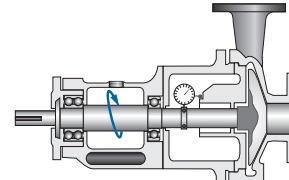
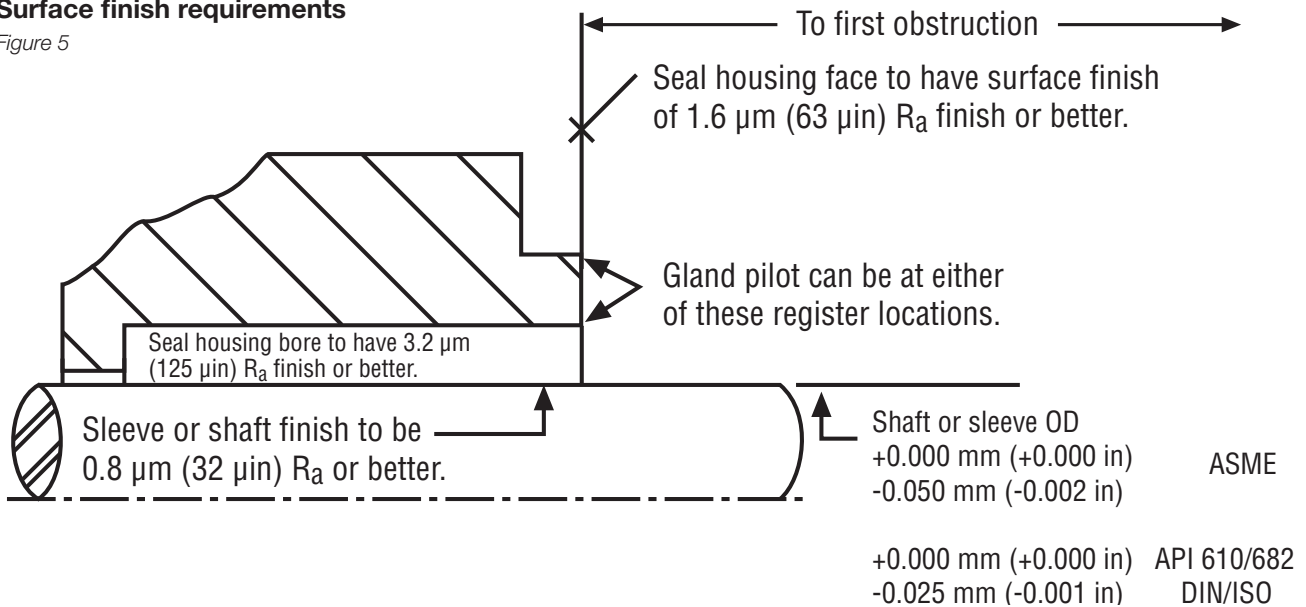

Figure 4

The images of parts shown in these instructions may differ visually from the actual parts due to manufacturing processes that do not affect the part function or quality.

Surface finish requirements

Figure 5



2. Seal installation

Cartridge high-temperature bellows seals are packaged in a manner to protect the flexible graphite gaskets during shipping. Carefully unpack the cartridge seal and separate the gaskets. **Flexible graphite gaskets are very fragile; handle with care.**

- 2.1 Some mechanical seals are sensitive to rotation direction. Verify that the directional rotation of the shaft corresponds to that of the mechanical seal before installation. Seals for between bearings shaft pumps may use different designs for each end of the pump; check the seal assembly drawings carefully.
- 2.2 Remove the axial drive collar screws and drive collar, if installed.
- 2.3 Place seal gland gasket into its groove. Small dots of grease may be applied in the seal gland gasket groove in four to six places to hold the gasket in position. Care must be taken not to get grease on the seal faces.
- 2.4 If the sleeve includes a sacrificial O-ring, lightly lubricate it to facilitate sliding along the shaft. Use a lubricant appropriate for the application.

2.5 For overhung shaft pumps:

- 2.5.1 Slide the drive collar onto the shaft with the gasket side of the collar facing the seal chamber. Note: the gasket is installed separately, in the next step. If the collar assembly includes a key drive, pin and/or lock ring, install these items. Again, refer to the assembly drawing.
- 2.5.2 Carefully slide the flexible graphite gasket along the pump shaft and seat uniformly against the drive collar.
- 2.5.3 Carefully slide the cartridge assembly onto the shaft and near the drive collar. Large size seals may require assistance to work safely and avoid seal damage. Refer to the assembly drawing for proper orientation and approximate axial position.

2.6 For between bearings shaft pumps:

- 2.6.1 Carefully slide the cartridge assembly onto the shaft and against the seal chamber. Large size seals may require assistance to work safely and avoid seal damage. Refer to the assembly drawing for proper orientation and approximate axial position.

High-Temperature Metal Bellows Seals Installation Instructions

- 2.6.2 Carefully slide the flexible graphite gasket along the pump shaft and seat uniformly against the sleeve.
- 2.6.3 Slide the drive collar onto the shaft with the gasket side of the collar facing the sleeve gasket. If the collar assembly includes a key drive, pin and/or lock ring, install these items. Again, refer to the assembly drawing. Do not lock the collar in place.
- 2.7 Start threading the axial drive collar bolts each a few thread turns. The collar assembly should remain loose.
- 2.8 Rebuild the pump and lock the shaft in its operating position without disturbing the seal assembly and drive collar.
- 2.9 Bolt the seal gland to the seal chamber. Use uniform torque on bolts to assure contact with seal chamber face and squareness with shaft.
- 2.10 Tighten axial drive collar bolts evenly to compress flexible graphite gasket to sleeve and pump shaft. Apply approximately 5.6 N-m (50 in-lbs) of torque. A gap may remain between the drive collar and adjusting collar. This gap should be uniform around the entire collar assembly.
- 2.11 Tighten drive collar set screws evenly to the shaft. Refer to the seal assembly drawing for torque specification.
- 2.12 Loosen setting device attachment bolts, rotate setting devices clear of the drive collar, and re-tighten bolts.

3. Piping instructions

Piping instructions are shown on the mechanical seal assembly drawing. These instructions must be followed precisely to ensure correct seal operation. For auxiliary systems, carefully read the operating instructions provided with the system.

Establishing proper lubrication at the mechanical seals is the first step toward reliable operation. Startup procedures and piping designs must ensure all air and gas are vented from the pump casing, seal chamber and piping system. Do not start the equipment dry.

Orifices should be installed as far away from the seal gland as possible. An exception to this rule should be made for orifices fitted to drain piping. To avoid clogging, install it at the seal gland so that conducted heat will serve to keep any leakage in a fluid state.

Per API 682/ISO 21039 and unless otherwise specified, the minimum internal diameter for piping should be 12.7 mm (0.500 in) for shaft sizes up to 60 mm (2.500 in). Larger shaft sizes should use a minimum pipe diameter of 19 mm (0.750 in).

For “loop type” systems (Plan 23, 52, and 53 A, B, C)

All piping loops should allow a high point vent. Minimize restrictions, total tube length and the number of bends. Use smooth, large-radius bends; do not use elbows, tees, etc. Tubing runs should be sloped continuously up or down to allow adequate circulation, proper venting and draining. Make sure the loop, including seal gland, does not include vapor traps. Unless otherwise specified, reservoirs and coolers must be mounted 45 to 60 cm (18 to 24 in) above the seal inlet or outlet connection, whichever is the highest, to promote thermal siphoning in standby conditions. Contact your Flowserve representative for additional information regarding proper reservoir installation.

For steam quench systems (Plan 62)

A steam quench is an essential plan on single high-temperature bellows seals. Steam pressure should be maintained less than 0.2 bar (3 psi) such that wisps of steam are visible exiting the seal gland area. Steam quench inlet should be on top of the gland with a drain at the bottom. Steam traps designed for this type of service should be installed and maintained. Before startup, ensure that all condensate is drained from the supply line. Open the steam quench slowly before the pump is preheated to prevent thermal shock.

Seals equipped with excess leakage detection

Excess leakage detection, used normally with single seals or dual unpressurized seals, is commonly achieved by monitoring liquid level or pressure increases. With such an arrangement, the drain line must slope down continuously to the point of exit.

4. Performance testing of pumps

Pump manufacturers will often run pump performance tests on water with the mechanical seal installed. If the product pumped during field operation is not equal to water, then seal designs and face materials will require special precautions to prevent damage to the seals during these tests. For example, in seals with two hard faces, alternate face materials or seal designs may be provided that are more suitable to the test medium. These faces are to be replaced with the specified face materials after testing is complete. A mechanical seal with a hard face combination can be safely tested on water, provided that seal chamber pressure during the test does not exceed 5 bar (73 psi) and face speeds do not exceed 10 m/s (33 ft/s).

When high-temperature seals with flexible graphite gaskets are tested on water, the seals must be carefully dried to remove any water that may have been absorbed by the gaskets. Any remaining water may vaporize when exposed to high product temperatures and damage gaskets. Rebuilding flexible graphite gasketed seals after water testing is recommended to prevent this issue.

5. Operational recommendations

- 5.1 The shaft speed and pressure and temperature in the seal chamber must not exceed the maximum seal limits.
- 5.2 For seals using external cooling or flush, these fluids must be supplied before startup and before product is introduced to the pump.
- 5.3 Avoid unnecessary valves in any seal support system. Critical fluid flow will be stopped if these valves are inadvertently closed.
- 5.4 Single and dual non-pressurized (tandem) seals require adequate vapor pressure margin in the seal chamber to prevent flashing of the product at the seal faces.
- 5.5 Dual non-pressurized (tandem) seals require buffer fluid pressure below seal chamber pressure at all times.
- 5.6 Dual pressurized (double) seals require barrier fluid pressure at least 2 bar (30 psi) above seal chamber pressure at all times. It is imperative to pressurize the barrier fluid before pressurizing the equipment to prevent product intrusion into the barrier system. Likewise, pressure must be maintained on the barrier fluid until the equipment has been fully isolated, depressurized and vented.
- 5.7 Ensure that the barrier/buffer fluid is clean and compatible with the product. The buffer/barrier fluid must contain little or no additives for anti-wear/oxidation. Automotive antifreeze should never be used. Flowserve can provide information on barrier/buffer temperatures and flow requirements based on product type, seal size, product temperature, barrier/buffer fluid characteristics and shaft speed. Dual gas seals should use clean steam at all times.
- 5.8 This seal is designed to resist corrosion by the product(s) listed on the assembly drawing. Do not expose the seal materials to products other than those shown on the assembly drawing. The seal assembly drawing lists the materials of construction. Consult your Flowserve representative when in doubt or when using the seal for another application than for which it was selected.
- 5.9 Liquid seal requirements:
 - 5.9.1 Do not start the equipment dry.
 - 5.9.2 Vent all air and/or product vapor from the equipment casing and the seal chamber before startup. Vent casing and tubing of heat exchanger (if applicable).
 - 5.9.3 Process fluid must flood and pressurize the seal chamber at all times for single and dual non-pressurized (tandem) seals. Barrier/buffer fluid must flood dual seals at all times during equipment operation, and pressurized seals must be pressurized above the process pressure at all times.

- 5.10 Steam seal requirements (Plan 72, 74):
- 5.10.1 Clean, dry, superheated steam is required.
 - 5.10.2 Pressurized steam seals (e.g., GTSP) require 3.4 bar (50 psi) greater than seal chamber pressure supplied to the seal at all times.
 - 5.10.3 Containment seals (e.g., GSDH) require a steam purge up to 0.7 barg (10 psig) supplied to the seal at all times.
 - 5.10.4 Take proper precautions to prevent steam condensate from entering the seal. Steam traps should be located at low points in the piping. Steam should be taken from the top of the steam header to prevent contaminants from entering the steam barrier stream. Contact your Flowserve representative to review piping runs and ensure that minimum requirements for satisfactory seal performance have been met.
- 5.11 Steam quench requirements (Plan 62):
- 5.11.1 Dry steam should be supplied to the seal gland quench connection.
 - 5.11.2 Use a needle valve (or other flow restriction) to provide less than 0.2 bar (3 psi) steam to the quench connection of the seal gland.
 - 5.11.3 Ensure that all condensate is drained from the supply line and open the supply slowly before the pump is preheated to prevent thermal shock.
 - 5.11.4 Proper pressure and steam condition should result in wisps of steam exiting the seal gland area.
- 5.12 Start up equipment in accordance with normal operating procedures unless specifically requested otherwise by Flowserve. If the equipment is not operating correctly, shut down the equipment, investigate, and remove the cause.

6. Repair

This product is a precision sealing device. The design and dimension tolerances are critical to seal performance. Only parts supplied by Flowserve should be used to repair a seal. To order replacement parts, refer to the part code and B/M number. A spare backup seal should be stocked to reduce repair time.

When seals are returned to Flowserve for repair, **decontaminate the seal assembly** and include an order marked **“Repair or Replace.” A signed certificate of decontamination must be attached. A Safety Data Sheet (SDS) must be enclosed** for any product that came in contact with the seal. The seal assembly will be inspected and, if repairable, it will be rebuilt, tested and returned.



Flowserve Corporation
5215 North O'Connor Blvd.
Suite 2300
Irving, Texas 75039-5421 USA
Telephone: +1 937 890 5839

FIS113-02 (ENA4) October 2020

Flowserve Corporation has established industry leadership in the design and manufacture of its products. When properly selected, this Flowserve product is designed to perform its intended function safely during its useful life. However, the purchaser or user of Flowserve products should be aware that Flowserve products might be used in numerous applications under a wide variety of industrial service conditions. Although Flowserve can provide general guidelines, it cannot provide specific data and warnings for all possible applications. The purchaser/user must therefore assume the ultimate responsibility for the proper sizing and selection, installation, operation, and maintenance of Flowserve products. The purchaser/user should read and understand the Installation Instructions included with the product, and train its employees and contractors in the safe use of Flowserve products in connection with the specific application.

While the information and specifications contained in this literature are believed to be accurate, they are supplied for informative purposes only and should not be considered certified or as a guarantee of satisfactory results by reliance thereon. Nothing contained herein is to be construed as a warranty or guarantee, express or implied, regarding any matter with respect to this product. Because Flowserve is continually improving and upgrading its product design, the specifications, dimensions and information contained herein are subject to change without notice. Should any question arise concerning these provisions, the purchaser/user should contact Flowserve Corporation at any one of its worldwide operations or offices.

©2020 Flowserve Corporation. All rights reserved. This document contains registered and unregistered trademarks of Flowserve Corporation. Other company, product, or service names may be trademarks or service marks of their respective companies.