

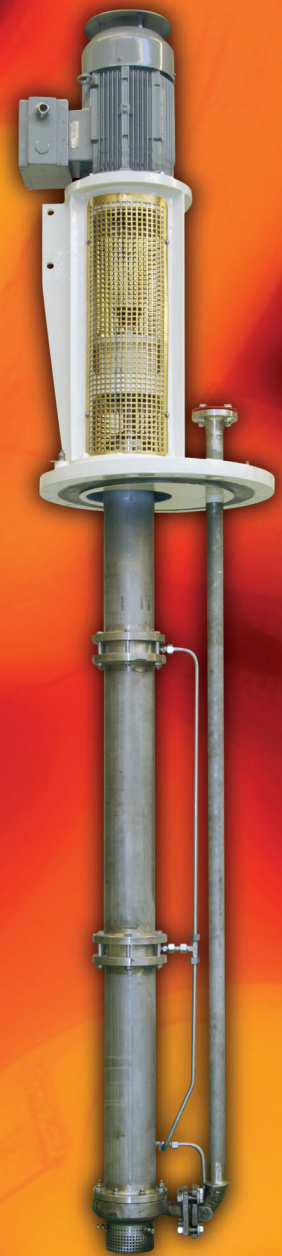

***ECPJ
API 610 (VS4)
Vertical Sump Pump***

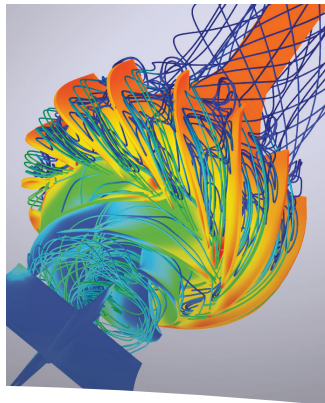

Experience In Motion

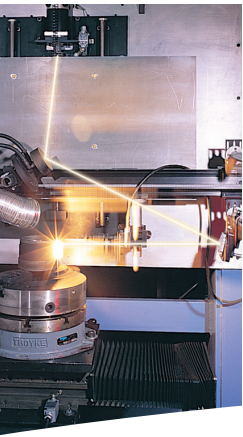

Pump Supplier to the World

Flowserve is the driving force in the global industrial pump marketplace. No other pump company in the world has the depth or breadth of expertise in the successful application of pre-engineered, engineered, and special purpose pumps and systems.

Life Cycle Cost Solutions

Flowserve provides pumping solutions that permit customers to reduce total life cycle costs and improve productivity, profitability and pumping system reliability.

Market-Focused Customer Support

Product and industry specialists develop effective proposals and solutions directed toward market and customer preferences. They offer technical advice and assistance throughout each stage of the product life cycle, beginning with the initial inquiry.

Broad Product Lines

Flowserve offers a wide range of complementary pump types, from pre-engineered process pumps to highly engineered and special purpose pumps and systems. Pumps are built to recognized global standards and customer specifications.

Pump designs include:

- Single-stage process
- Between bearings single-stage
- Between bearings multistage
- Vertical
- Submersible motor
- Positive displacement
- Nuclear
- Specialty

Product Brands of Distinction

ACEC™ Centrifugal Pumps

Aldrich™ Pumps

Byron Jackson® Pumps

Calder™ Energy Recovery Devices

Cameron™ Pumps

Durco® Process Pumps

Flowserve® Pumps

IDP® Pumps

INNOMAG™ Sealless Pumps

Lawrence Pumps®

Niigata Worthington™ Pumps

Pacific® Pumps

Pleuger® Pumps

Scienco™ Pumps

Sier-Bath® Rotary Pumps

TKL™ Pumps

United Centrifugal® Pumps

Western Land Roller™ Irrigation Pumps

Wilson-Snyder® Pumps

Worthington® Pumps

Worthington Simpson™ Pumps

ECPJ
Vertical Sump Pump
 ISO 13709/API 610 (VS4)

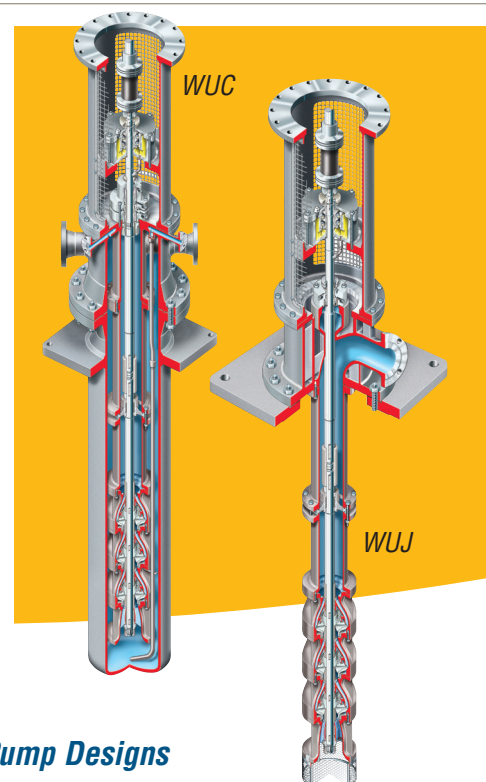

Versatile, Reliable Performer

The Flowserve ECPJ is a rugged, single-stage vertical lineshaft sump pump designed to perform tough jobs reliably, under a variety of difficult conditions. Based on a modular design system, the ECPJ pump provides dependable performance while offering maximum mechanical and hydraulic design flexibility. Fully compliant with ISO 13709/API 610 (VS4), latest edition, each ECPJ pump can be custom engineered for the specific application in which it will be used.

Complementary Pump Designs

In addition to the ECPJ, Flowserve also can provide the following complementary API standard pump designs:

- WUJ ISO 13709/API 610 (VS1) wet-pit pump
- WUC ISO 13709/API 610 (VS6) vertical, double casing, multistage pump
- CPXV ISO vertical sump pump

Broad Application

- Petrochemical processing
- Chemical processing
- Refinery offsites
- Drainage
- High temperature transfer
- Gas and coal processing
- Liquid sulfur
- Molten salts
- Slops



ECPJ
Vertical Sump Pump
 ISO 13709/API 610 (VS4)

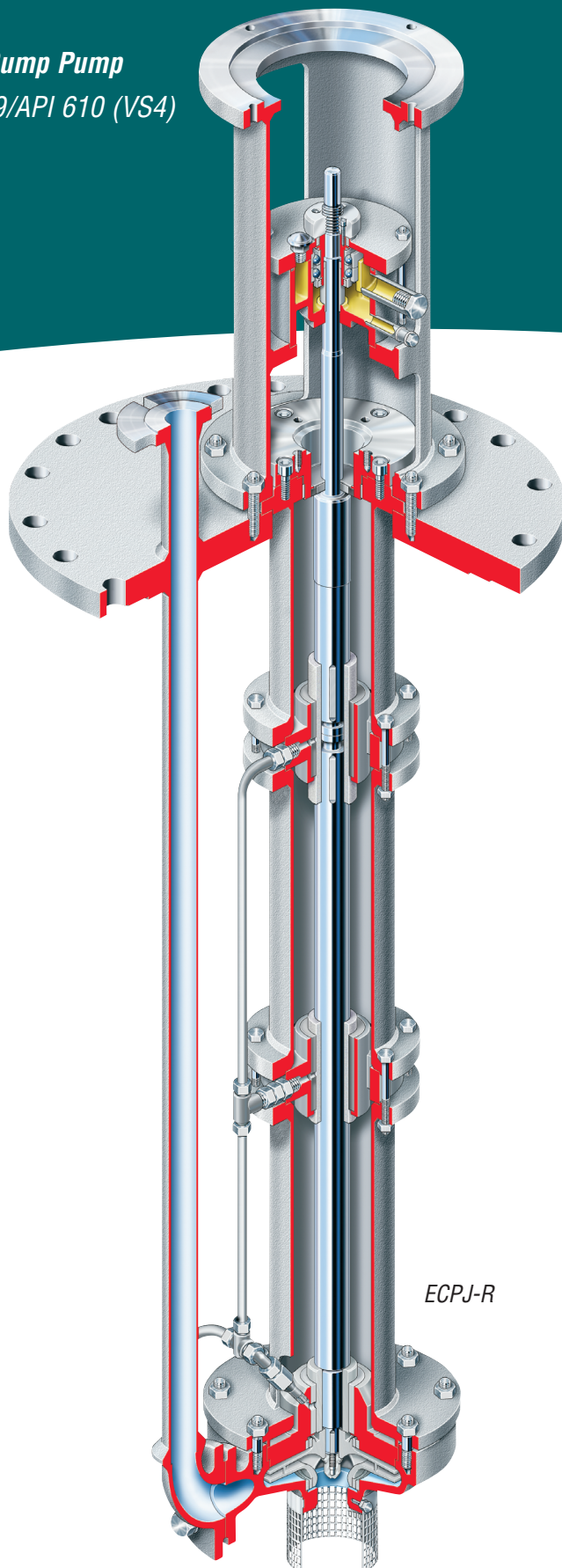

The ECPJ vertical sump pump is a proven performer in chemical and hydrocarbon processing, delivering reliable performance in a wide range of applications. Fully compliant with ISO 13709/API 610 (VS4) specifications, the ECPJ is available in 45 sizes. A range of impeller and casing designs allows the pump's hydraulic characteristics to be tailored to service requirements.

Operating Parameters

- Flows to 1000 m³/h (4400 gpm)
- Heads to 150 m (500 ft)
- Pressures to 20 bar (285 psi)
- Temperatures to 350°C (660°F)
- Column lengths to 8 m (26 ft)
- 45 sizes available

Pump Casing and Cover features metal to metal fit with fully confined, controlled compression gasket to endure proper sealing and alignment.

Dynamically Balanced Precision Cast Impeller limits vibration and ensures smooth operation over a wide flow range. An anti-rotation impeller nut positively locks the impeller to the shaft without exposing its threads to the pumped fluid.

ISO 21049/API 682 Seal Chambers allow for installation of cartridge style single and dual pressurized mechanical seals to meet required safety and environmental requirements.

ECPJ-R

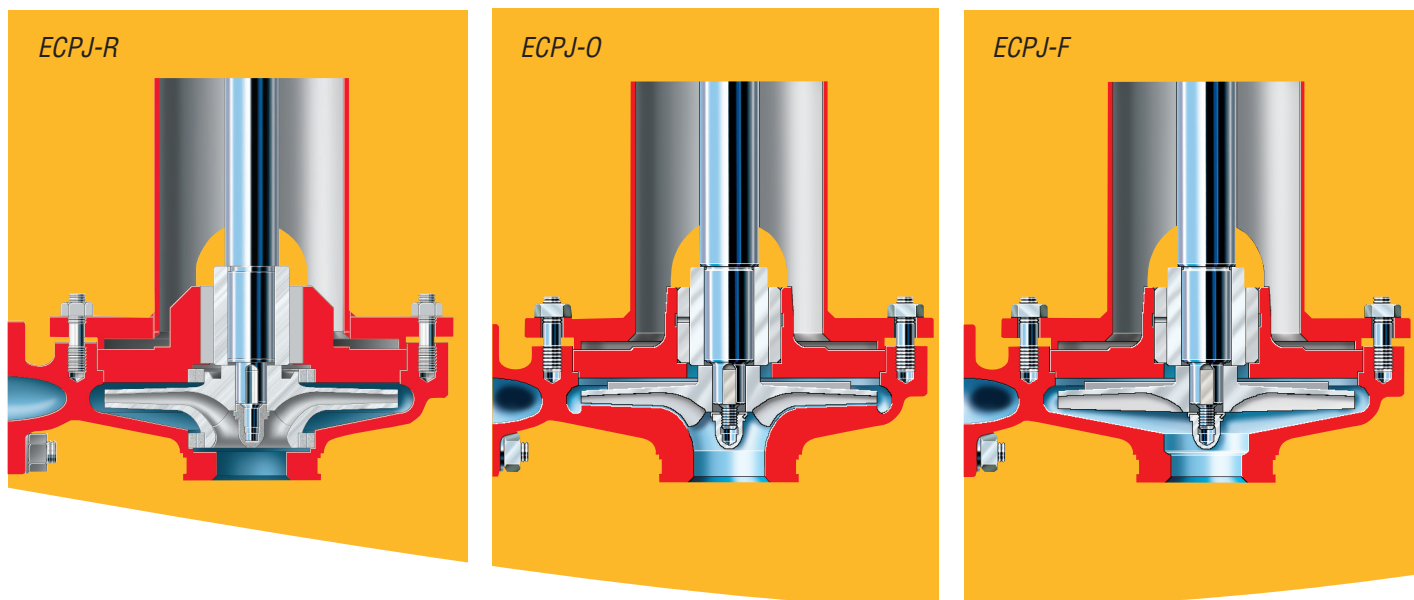

Multiple Hydraulic Designs

The ECPJ is available in three ISO 13709/API 610 compliant hydraulic designs. Impeller and casing configurations should be selected to suit application.

- ECPJ-R
 - Closed multivane impeller with front and back wear rings
 - Standard design suitable for most applications
- ECPJ-O
 - Open multivane impeller with back vanes
 - Suitable for handling soft particles like PTA applications
- ECPJ-F
 - Free flow impeller with back vanes
 - Recommended for enhanced solids handling capability
- ECPJ-L
 - Barske-type, semi-open, radial impeller with 27 straight vanes
 - Exceptional low-flow stability with continuously rising pump curve

Bearing Configurations

The ECPJ pump features a thrust pot with oil lubricated API 40° angular contact bearings in back-to-back arrangement. This enables standard (non-thrust) electrical motors to be used and fulfills ISO 13709/API 610 bearing life criteria.

Lineshaft bearings are available in several metallic and non-metallic materials to suit application needs.

Available Baseplate Designs

Several baseplate designs are available for the ECPJ.

- Rectangular
 - Non-pressurized
 - Foundation or steel structure mounting
- Circular
 - DIN 2501 PN 10 — Tank pressures to 9 bar (130 psi)
 - ANSI 150 lb
 - ANSI 300 lb
- Customer-specific dimensions

Stable Low-Flow Performance

The ECPJ-L with its Barske-type impeller meets the API 610 requirements of preferred and rated flow range. Individually machined impeller and insert ring combinations provide optimized BEP performance. Whenever a low-flow, high-head application requires special attention, the ECPJ-L will be the right choice (limited to 200°C [392°F]).

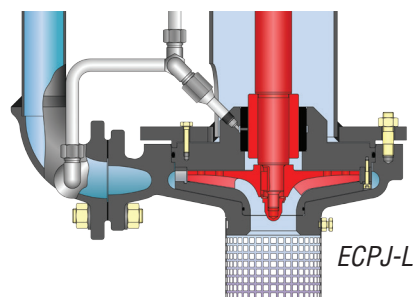

ECPJ-H for Liquid Sulfur Service

A steam jacketed version of the ECPJ, called the ECPJ-H, is available for applications in which it is critical that the process fluid not drop below a critical threshold, such as liquid sulfur service. This model may be used with any of the three hydraulic designs and includes cast iron lineshaft bearings with a flush.

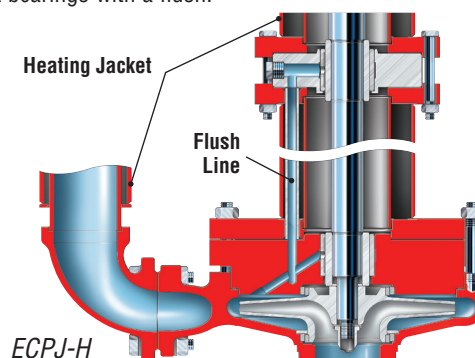

Options and Technical Data

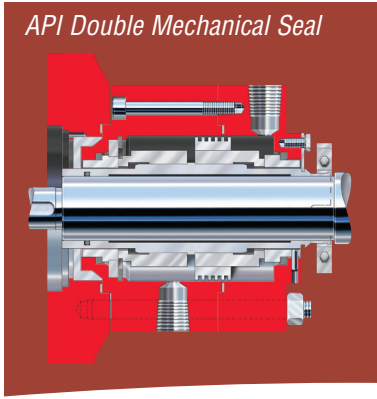

API Double Mechanical Seal

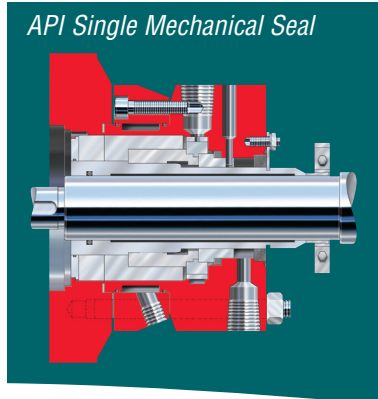

API Single Mechanical Seal



Inducer

Shaft Sealing Options

The ECPJ is available with multiple shaft sealing options. Multiple seal types, including ISO 13709/API 610 compliant cartridge seal designs, are available to suit application needs.

- V-Ring
- Throttle bushing
- Lip seal with grease-filled stuffing box
- Soft packing
- ISO 21049/API 610 compliant cartridge designs
 - Single mechanical seal, including dry running types
 - Pressurized double mechanical seal

Materials of Construction

The ECPJ is available in a broad range of materials, including ISO 13709/API 610 and NACE MRO175 compliant alloys. It is also available in specialty materials such as titanium.

Optional Inducer

An inducer is available when suction conditions are critical. The design reduces backflow and guarantees trouble-free operation over a broad flow range.

Additional Options

- Steam heating
- Suction strainer
- Bearing cooling (API Plan A)
- Internal or external bearing flushing
- Multiple API seal flushing, barrier fluid and quench system piping plans
- Suction pipe
- Length can be set above 8 m (26 ft) upon request

ECPJ Range Chart

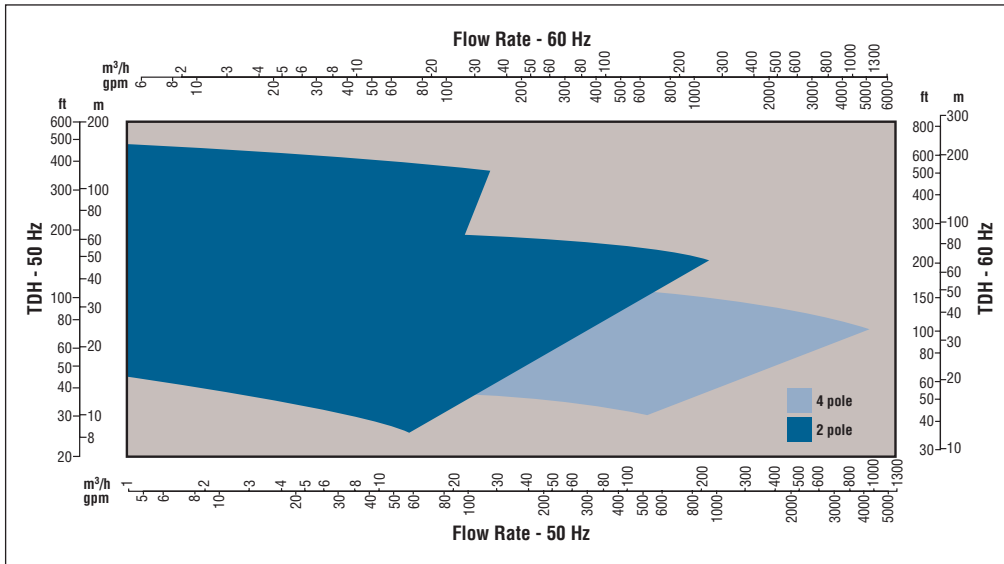

**Global Service
and Technical
Support**

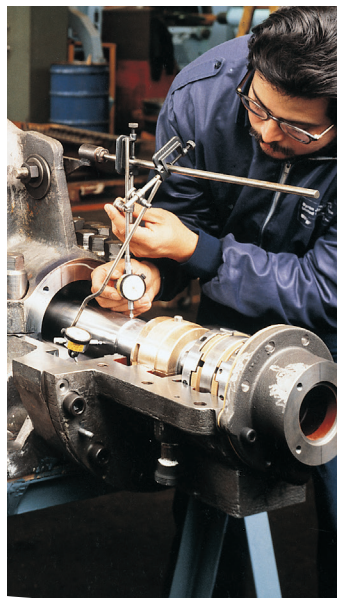

Life Cycle Cost Solutions

Typically, 90% of the total life cycle cost (LCC) of a pumping system is accumulated after the equipment is purchased and installed. Flowserve has developed a comprehensive suite of solutions aimed at providing customers with unprecedented value and cost savings throughout the life span of the pumping system. These solutions account for every facet of life cycle cost, including:

Capital Expenses

- Initial purchase
- Installation

Operating Expenses

- Energy consumption
- Maintenance
- Production losses
- Environmental
- Inventory
- Operating
- Removal

Innovative Life Cycle Cost Solutions

- New Pump Selection
- Turnkey Engineering and Field Service
- Energy Management
- Pump Availability
- Proactive Maintenance
- Inventory Management

Typical Pump Life Cycle Costs¹

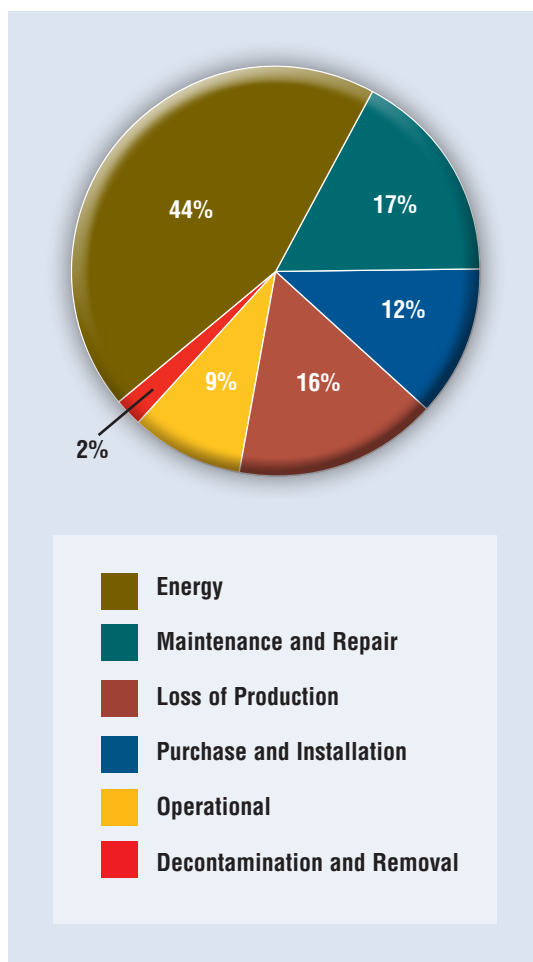

¹ While exact values may differ, these percentages are consistent with those published by leading pump manufacturers and end users, as well as industry associations and government agencies worldwide.



USA and Canada

Flowserve Corporation
5215 North O'Connor Blvd.
Suite 2300
Irving, Texas 75039-5421 USA
Telephone: +1 937 890 5839

Europe, Middle East, Africa

Flowserve Corporation
Parallelweg 13
4878 AH Etten-Leur
The Netherlands
Telephone: +31 76 502 8100

Latin America

Flowserve Corporation
Martín Rodríguez 4460
B1644CGN-Victoria-San Fernando
Buenos Aires, Argentina
Telephone: +54 11 4006 8700
Telefax: +54 11 4714 1610

Asia Pacific

Flowserve Pte. Ltd.
10 Tuas Loop
Singapore 637345
Telephone: +65 6771 0600
Telefax: +65 6862 2329

Bulletin PS-10-10b (E/A4) September 2016. © 2016 Flowserve Corporation

To find your local Flowserve representative:

For more information about Flowserve Corporation,
visit www.flowserve.com or call +1 937 890 5839.