



USER INSTRUCTIONS

Limitorque® B320 Series

FCD LMENIM3201-02 – 01/15

Installation
Operation
Maintenance

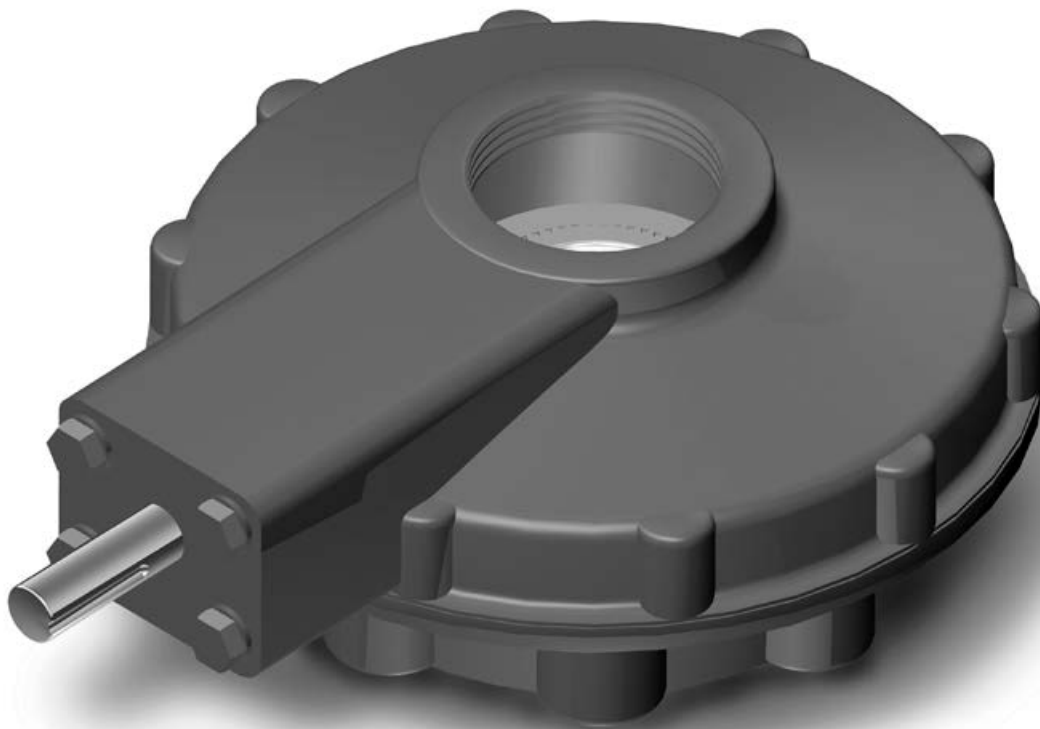

This page is left intentionally blank.

Contents

1	Introduction	5
1.1	Purpose	5
1.2	User Safety	5
2	Product Capabilities and Features	6
2.1	Initial Inspection and Storage Instructions	6
2.2	Product Identification	7
2.3	Inspection and Recording	7
2.4	Storage Procedure	8
3	Operator Weights	9
4	Installation Instructions	10
4.1	Safety Precautions	10
4.2	Safety Practices	11
4.3	Installation	11
4.3.1	Installing an Operator with a Threaded Stem Nut	11
4.3.2	Installing an Operator with a Blank Stem Nut (B320-10 through -90, one-piece)	11
4.3.3	Installing an Operator with a Blank Stem Nut (B320-90, two-piece)	12
5	Lubrication	13
5.1	Lubrication Inspection	13
5.2	Factory Lubricant	13
5.3	Minimum Lubricant Qualities Required	14
6	Disassembly and Reassembly	15
6.1	Disassembly and Reassembly of B320-10 through -80	16
6.1.1	Disassembly	16
6.1.2	Reassembly	16
6.2	Disassembly and Reassembly of B320-90	20
6.2.1	Disassembly	20
6.2.2	Reassembly	20
6.3	Disassembly and Reassembly of Spur Gear Attachments	21
6.3.1	Disassembly of 3:1 Spur Gear Attachment for B320-10 through -40	21
6.3.2	Reassembly of 3:1 Spur Gear Attachment for B320-10 through -40	22
6.3.3	Disassembly of 6.3:1, 10.3:1, and 10.8:1 Spur Gear Attachments for B320-50, -70, and -80	23
6.3.4	Reassembly of 6.3:1, 10.3:1, and 10.8:1 Spur Gear Attachments for B320-50, -70, and -80	23
6.3.5	Disassembly of 5:1 Spur Gear Attachment for B320-90	25
6.3.6	Reassembly of 5:1 Spur Gear Attachment for B320-90	25
6.3.7	Disassembly of 17.5:1 Spur Gear Attachment for B320-90	27
6.3.8	Reassembly of 17.5:1 Spur Gear Attachment for B320-90	27
7	How to Order Parts	30

Figures

Figure 2.1 – B320 Bevel Gear Operator	7
Figure 2.2 – B320 Nameplate	8
Figure 6.1 – B320-10 and 20 Parts Diagram	17
Figure 6.2 – B320-30 and -40 Parts Diagram	17
Figure 6.3 – B320-50 and -70 Parts Diagram	18
Figure 6.4 – B320-80 Parts Diagram	18
Figure 6.5 – B320-90 Parts Diagram	20
Figure 6.6 – 3:1 SGA Parts Diagram for B320-10 through -40	22
Figure 6.7 – 6.3:1, 10.3:1, and 10.8:1 SGA Parts Diagram for B320-50 through 80	24
Figure 6.8 – 5:1 SGA Parts Diagram for B320-90	26
Figure 6.9 – 17.5:1 SGA Parts Diagram for B320-90	28

Tables

Table 3.1 – Operator Weights	9
Table 5.1 – Lubricant Quantities	14
Table 6.1 – Quantity of Ball Bearings	15
Table 6.2– Common Parts List	19
Table 6.3 – B320-90 Parts List	21
Table 6.4 – 3:1 SGA Parts List for B320-10 through -40	23
Table 6.5 – 6.3:1 , 10.3:1, and 10.8:1 SGA Parts List for B320-50 through 80	24
Table 6.6 – 5:1 SGA Parts List for B320-90	26
Table 6.7 – 17.5:1 SGA Parts List for B320-90	29

1 Introduction

1.1 Purpose

This Installation, Operation and Maintenance Manual (IOM) explains how to install and maintain the B320 bevel gear operator. Information on installation, disassembly, lubrication, and spare parts is provided.

1.2 User Safety

Safety notices in this manual detail precautions the user must take to reduce the risk of personal injury and damage to the equipment. The user must read and be familiar with these instructions before attempting installation, operation, or maintenance. Failure to observe these precautions could result in serious bodily injury, damage to the equipment, void of the warranty, or operational difficulty.

Safety notices are presented in this manual in three forms:

⚠ **WARNING:** Refers to personal safety. Alerts the user to potential danger. Failure to follow warning notices could result in personal injury or death.

⚠ **CAUTION:** Directs the user's attention to general precautions that, if not followed, could result in personal injury and/or equipment damage.

NOTE: Highlights information critical to the user's understanding of the gear operator's installation and operation.

2

Product Capabilities and Features

Designed to make operation of multi-turn valves easier The B320 gear operator makes it easier to both manually operate multi-turn valves and convert to a motorized service.

Built for reliable valve control — whether manual or motorized The B320 offers torque ranges up to 8,000 ft-lb (10,856 N m) and thrust capacities to 325,000 lb (1,445 kN) for any application demanding superior strength and accuracy.

Easily adaptable for other applications The B320 is designed to be configured to each customer's needs:

- Optional handwheel available for manual actuation
- Add a spur gear attachment for greater mechanical advantage
- Couple with an electric actuator from Limitorque for an economical, motorized, multi-turn package

2.1 Initial Inspection and Storage Instructions

⚠ **WARNING:** Read this Installation, Operation and Maintenance Manual carefully and completely before attempting to store the gear operator.

2.2 Product Identification

Figure 2.1 – B320 Bevel Gear Operator

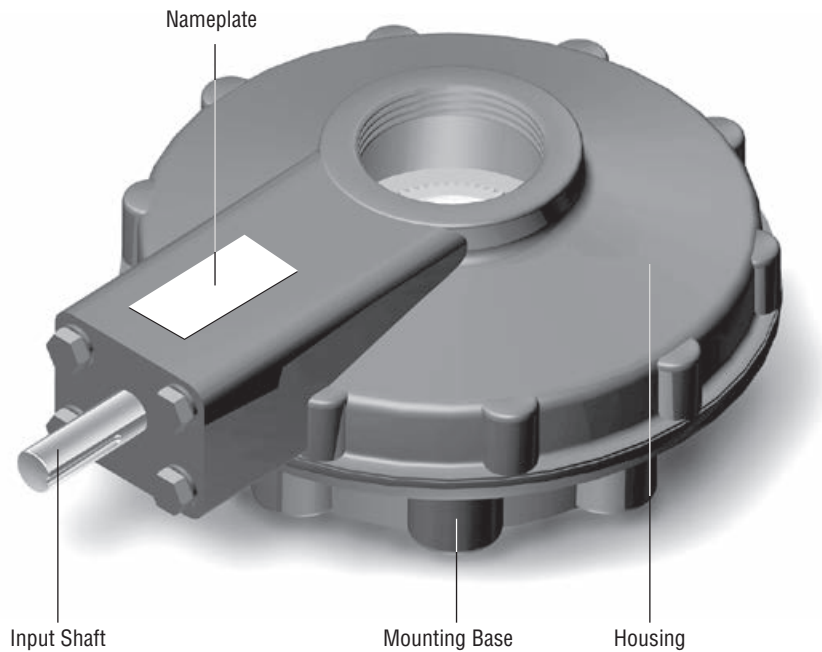

2.3 Inspection and Recording

Upon receipt of the gear operator, inspect the condition of the equipment and record nameplate information.

1. Carefully remove gear operator from shipping carton or skid. Thoroughly examine the equipment for any physical damage that may have occurred during shipment. If damaged, immediately report the damage to the transport company.
2. A nameplate is attached to each gear operator with the following information:
 - Operator Size
 - Limitorque Order Number
 - Ratio
 - Serial Number

Record this information for future reference, for ordering parts or obtaining further information.

Figure 2.2 – B320 Nameplate



2.4 Storage Procedure

NOTE: The following is the recommended storage procedure to retain maximum product integrity during storage. Failure to comply with recommended procedure will void the warranty.

Storage (Less Than One Year)

Operators should be stored in a clean, dry, protected warehouse and should be stored on wooden skids to protect the machined mounting flange. If the operators must be stored outside, they must be covered in polyethylene protection with silica gel crystals to absorb moisture. Input shafts should be rotated every three months to mix lubricant.

3 Operator Weights

The approximate weights of the gear operators, with and without spur gear attachments, are provided below:

Table 3.1 – Operator Weights

Operator	Without SGA		With SGA	
	lb	kg	lb	kg
B320-10	45	21	75	34
B320-20	51	23	80	36
B320-30	57	26	86	39
B320-40	68	31	97	44
B320-50	143	65	198	90
B320-70	254	115	309	140
B320-80	418	190	474	215
B320-90	745	339	875	398

4

Installation Instructions

4.1 Safety Precautions

- ⚠ **WARNING:** Read this Installation, Operation and Maintenance Manual carefully and completely before attempting to install, operate, or troubleshoot the Limitorque operator.
- ⚠ **WARNING:** Potential HIGH PRESSURE vessel — be aware of high-pressure hazards associated with the attached valve or other actuated device when installing or performing maintenance on the operator. Do not remove the operator mounting bolts from the valve or actuated device unless the valve or device stem is secured or there is no pressure in the line.
- ⚠ **WARNING:** For maintenance and/or disassembly of the operator while installed on the valve, ensure that the operator is not under thrust or torque load. If the valve must be left in service, the valve stem must be locked in such a way as to prevent any movement of the valve stem.
- ⚠ **WARNING:** Do not manually operate the operator with devices other than the installed hand-wheel. Using force beyond the ratings of the operator and/or using additive force devices such as cheater bars, wheel wrenches, pipe wrenches, or other devices on the operator handwheel may cause serious personal injury and/or damage to the operator and valve.
- ⚠ **WARNING:** Do not exceed any design limitations or make modifications to this equipment without first consulting Limitorque.
- ⚠ **WARNING:** Use of the product must be suspended any time it fails to operate properly.
- ⚠ **CAUTION:** If a motor actuator is driving the manual operator, do not operate the valve under motor operation without first checking and setting the limit switch setting and checking for correct motor rotation.
- ⚠ **CAUTION:** Do not use replacement parts that are not genuine Flowserve Limitorque parts, as serious personal injury and/or damage to the operator and valve may result.

4.2 Safety Practices

The following check points should be performed to maintain safe operation of the B320 gear operator:

- Set up a periodic operating schedule on infrequently used valves.
- Ensure that the limit and/or torque switches on any electric actuator fitted to the bevel gear operator are correctly and appropriately adjusted.

4.3 Installation

The B320 series of gear operators has been designed to transmit torque as well as thrust. The gear operator can be supplied with a threaded stem nut, keyed stem nut, or a blank stem nut.

4.3.1 Installing an Operator with a Threaded Stem Nut

1. Position operator above the valve stem.
2. Rotate the operator handwheel or wrench nut several turns until there is positive engagement between the valve stem and the operator stem nut.
3. Rotate the handwheel to lower the operator onto the valve until contact has been made with the valve flange.
4. Bolt the gear operator securely to the valve mounting flange.

4.3.2 Installing an Operator with a Blank Stem Nut (B320-10 through -90, one-piece)

1. Remove the thrust ring from the base of the operator.
 - ▲ **CAUTION:** Care must be taken to ensure that the O-ring seals located on the ring are not damaged.
2. Remove the stem nut assembly consisting of a bronze nut and two needle roller bearings with washers.
3. Remove bearings and washers. Place them in a clean and dry area until reassembly.
4. Machine the stem nut to suit the valve stem.
 - ▲ **CAUTION:** Care should be taken to ensure that the clamping devices used during machining do not damage surfaces of the stem nut.
5. Reassemble the operator, reversing steps 1, 2, and 3.
 - a. Install bearings and washers onto the bronze stem nut.
 - b. Install the assembly into the thrust base.
 - c. Bolt the thrust base assembly to the main housing.

- ▲ **CAUTION:** Ensure that no dirt or foreign material enters the operator.

6. Using the specified lubricant, grease the thrust base assembly through the grease fitting. See Section 5 Lubrication, and Figure 6.1, 6.2, 6.3, 6.4 and 6.5 for grease fitting location.
7. Mount the operator on the valve as detailed in Section 4.3.1, Installing an Operator with a Threaded Stem Nut.

4.3.3 Installing an Operator with a Blank Stem Nut (B320-90, two-piece)

(Piece numbers refer to Figure 6.5 and Table 6.3).

1. Remove the key from the bottom of the operator. The key is located between the Thrust Drive Sleeve (piece #117) and the Stem Nut (piece #392). The key is tapped (1/4-20) to provide for removal.
2. Remove the Stem Nut by rotating in the proper direction. The Stem Nut is threaded into the Thrust Drive Sleeve (piece #394). A slot is provided on the end of the Stem Nut to aid in its removal.
3. Thread the Stem Nut to suit the valve stem.
▲ CAUTION: Do not clamp the splined area of the Stem Nut during the tapping operation.
4. Reassemble the operator, reversing steps 1 and 2. Stem Nuts should be positioned flush with the Thrust Drive Sleeve but can be recessed inward approximately 1/4 inch, if so desired. Stem Nuts can also be positioned to extend below the Thrust Drive Sleeve approximately 1/4 inch without jeopardizing the thrust rating of the operator. All Stem Nuts are threaded on the outside diameter using eight threads per inch.
5. Mount the operator on the valve as detailed in Section 4.3.1, Installing an Operator with a Threaded Stem Nut.

5

Lubrication

The B320 bevel gear operators have a sealed gear case, factory-lubricated with grease. No seal can remain absolutely tight at all times. Therefore, it is not unusual to find a very small amount of weeping around shaft seals — especially during long periods of idleness such as storage. Using grease minimizes this condition as much as possible. If a small amount is weeping at start-up, remove it with a clean cloth. Once the equipment is operating on a regular basis, the weeping should stop.

5.1 Lubrication Inspection

Inspect the B320 bevel gear operators for correct lubrication prior to operating — particularly following a storage period. We recommend the operators be checked during an overhaul program.

5.2 Factory Lubricant

The B320 series operator gear case is factory-lubricated with EP-0 lithium soap, mineral base grease, suitable for temperatures from -20°F (-29°C) to 225°F (107°C).

▲ CAUTION: Do not mix lubricants of dissimilar bases.

Table 5.1 – Lubricant Quantities

Operator	Without SGA		With SGA	
	lb	kg	lb	kg
B320-10	0.7	0.3	1.2	0.6
B320-20	0.7	0.3	1.2	0.6
B320-30	1.2	0.6	1.7	0.8
B320-40	1.2	0.6	1.7	0.8
B320-50	2.2	1.0	2.7	1.2
B320-70	4.0	1.8	4.5	2.0
B320-80	4.0	1.8	4.5	2.0
B320-90	4.2	1.9	6.7	3.1

5.3 Minimum Lubricant Qualities Required

The standard lubricants used by Limitorque have been proven to be extremely reliable over years of service. Lubricant substitute may be used; however, Limitorque does require the following lubricant qualities as a minimum.

The lubricant must

- contain an “EP” additive.
- be suitable for the temperature range intended.
- be water- and heat-resistant and non-separating.
- not create more than 8% swell in Buna N or Viton.
- not contain any grit, abrasive, or fillers.
- be slump-prefer NLGI-0 grade.
- not be corrosive to steel gears, balls, or roller bearings.
- have a dropping point above 316°F (158°C) for temperature ranges of -20°F to 150°F (-28°C to 65°C).

6

Disassembly and Reassembly

No special tools are required for assembly/disassembly of the B320 series bevel gear operators.

⚠ **WARNING:** Valve must be in fully opened position with no pressure in the line to perform work on the gear operator.

⚠ **CAUTION:** During disassembly and reassembly, all removed components should be cleaned and placed in an area free of dirt, water, or other foreign material.

⚠ **CAUTION:** Care should be taken in removing the ball bearings located between the bevel gear and thrust housing. These bearings are non-caged, hardened ground balls.

The table below indicates the number of ball bearings utilized by each B320 size.

Table 6.1 – Quantity of Ball Bearings

Operator	Quantity
B320-10	42
B320-20	42
B320-30	57
B320-40	57
B320-50	53
B320-70	74
B320-80	80
B320-90	66

6.1 Disassembly and Reassembly of B320-10 through -80

6.1.1 Disassembly

(Piece numbers refer to Figures 6.1, 6.2, 6.3, and 6.4).

1. Remove Thrust Ring (piece #5). Pull out Stem Nut (piece #4), Washers (piece #7) and Bearings (piece #6).
2. Remove Endcover (piece #20).
3. Slide out Bevel Pinion Shaft/Bearing Subassembly (piece #21, 22, and 23) together with Shims (piece #25).
4. Remove Housing (piece #1) from Base (piece #2).
5. Remove Bevel Gear (piece #3) and Ball Bearings (piece #8).

NOTE: Please note the number and position of each shim.

6.1.2 Reassembly

(Piece numbers refer to Figures 6.1, 6.2, 6.3, and 6.4).

1. Install Ball Bearings (piece #8) and Bevel Gear (piece #3) on Base (piece #2).
2. Attach Housing (piece #1) to Base (piece #2).
3. Slide in Bevel Pinion Shaft/Bearing Subassembly (piece #21, 22, and 23) together with Shims (piece #25).
4. Attach Endcover (piece #20).
5. Insert Thrust Washer (piece #7), Needle Bearing (piece #6) and another Thrust Washer (piece #7).
6. Insert Stem Nut (piece #4)
7. Insert Thrust Washer (piece #7), Needle Bearing (piece #6) and another Thrust Washer (piece #7).
8. Attach Thrust Ring (piece #5).

NOTE: Gasket compound is to be used on all metal/metal faces.

Figure 6.1 – B320-10 and -20 Parts Diagram

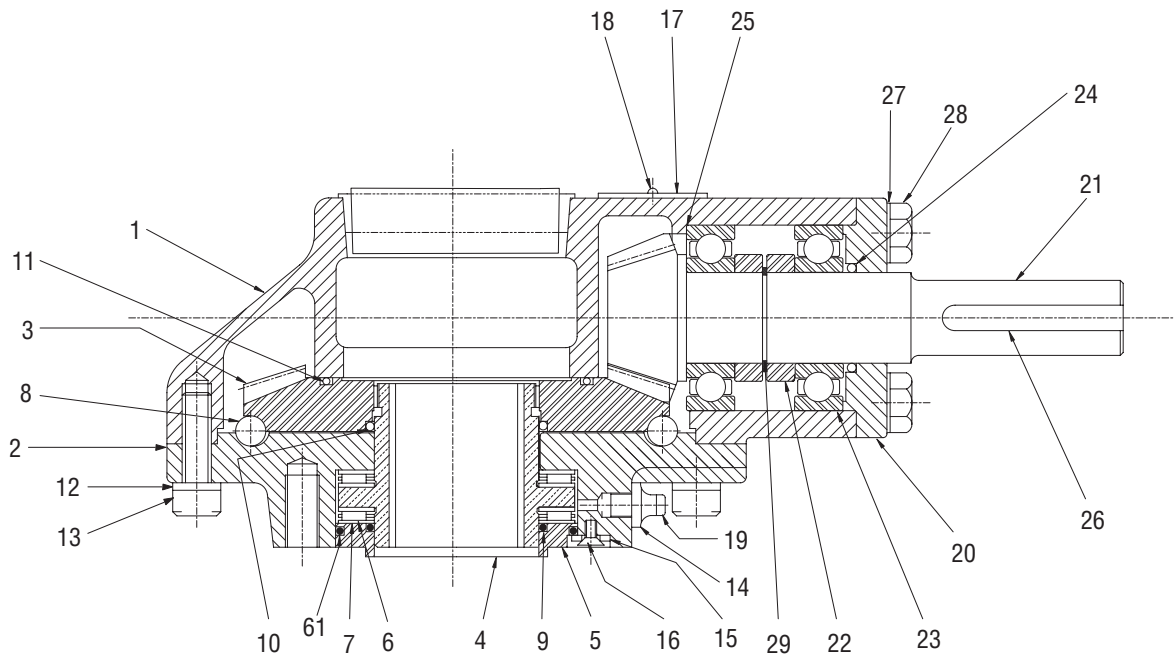

Figure 6.2 – B320-30 and -40 Parts Diagram

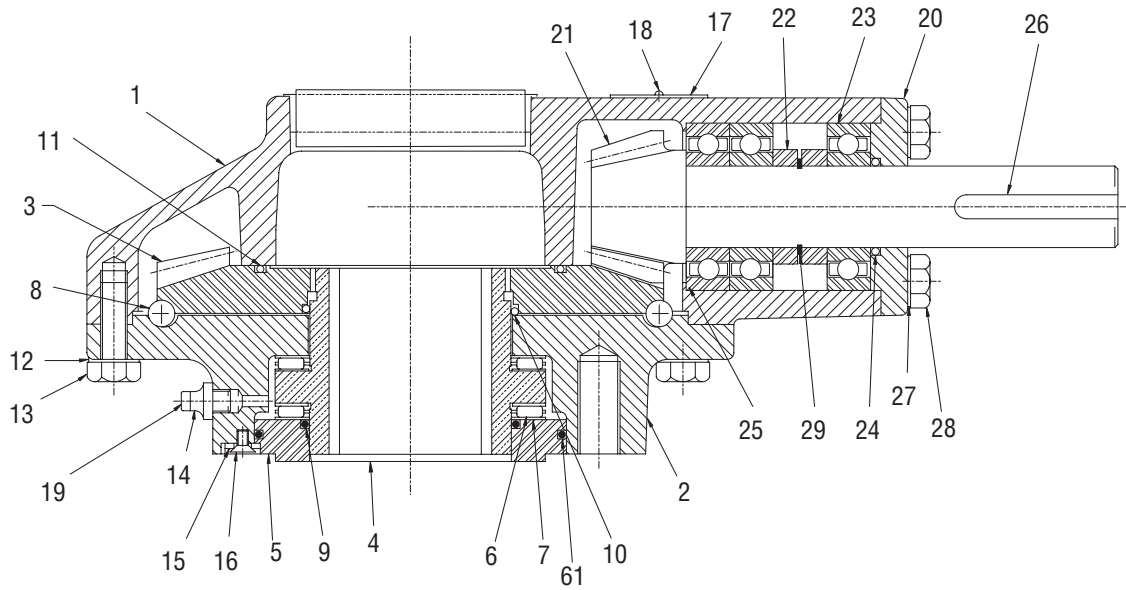

Figure 6.3 – B320-50 and -70 Parts Diagram

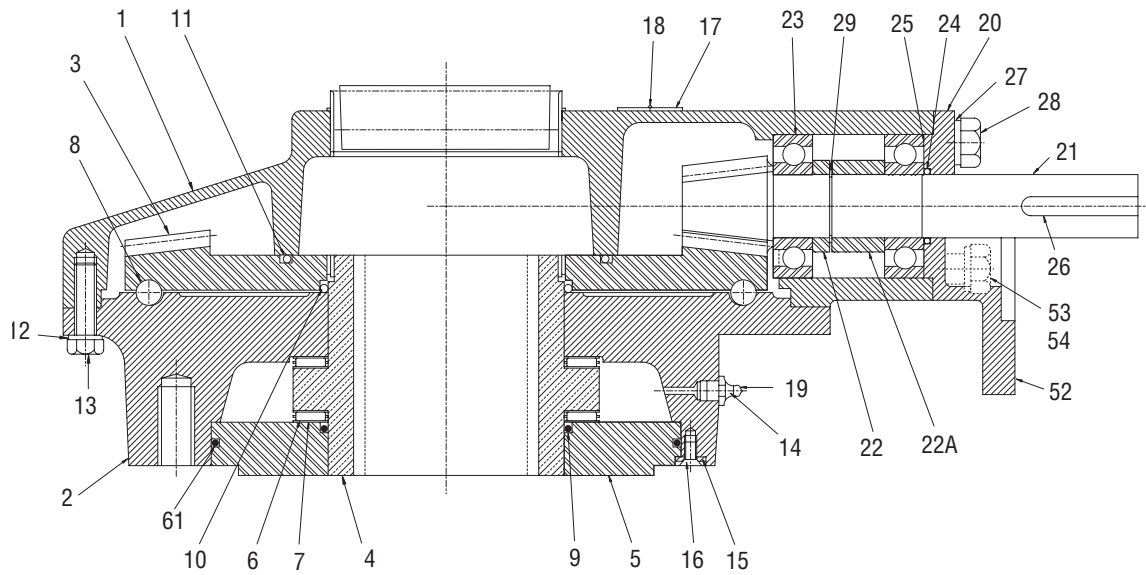

Figure 6.4 – B320-80 Parts Diagram

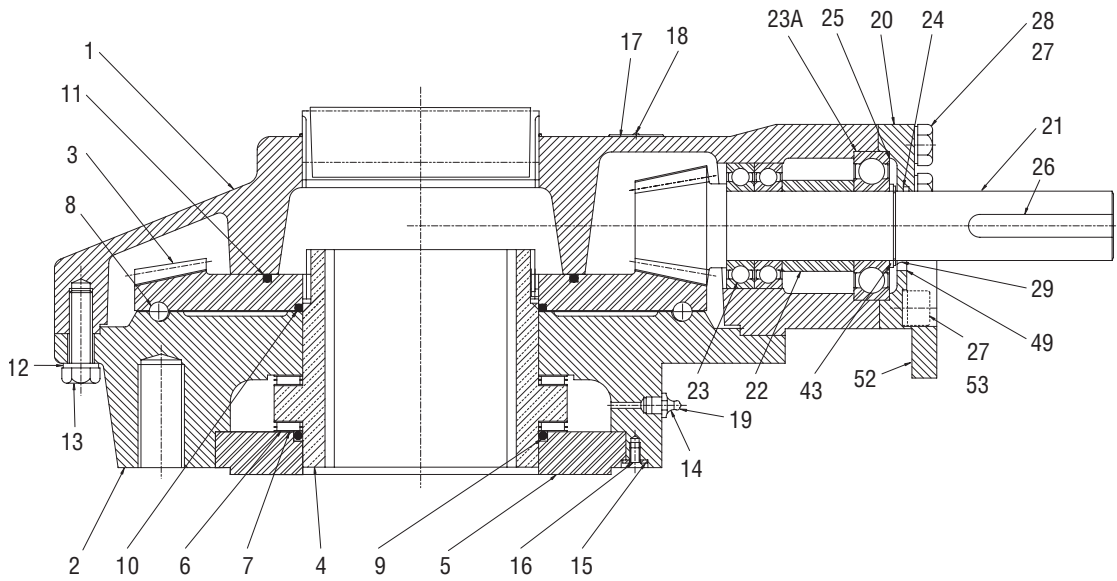

Table 6.2– Common Parts List

Piece	Quantity	Description
1	1	Housing
2	1	Base
3	1	Bevel Gear
4	1	Stem Nut
5	1	Thrust Ring
6	2	Needle Bearing
7	4	Thrust Washer
8	A/R	Ball Bearings
9	1	O-ring
10	1	O-ring
11	1	O-ring
12	A/R	Lockwasher
13	A/R	Hex Head Cap Screw
14	1	Grease Fitting
15	1	Plain Washer
16	1	Flat Head Mach. Screw
17	1	Nameplate
18	2	Drive Screw
19	1	Grease Fitting Cap
20	1	Endcover
21	1	Bevel Pinion
22 (B320-20)	2	Spacer
23 (B320-20)	2	Ball Bearing
22 (B320-40)	2	Spacer
23 (B320-40)	3	Ball Bearing
22 (B320-50)	2	Spacer
23 (B320-50)	2	Ball Bearing
22 (B320-70)	1	Spacer
22A (B320-70)	1	Spacer
23 (B320-70)	2	Spacer
22 (B320-80)	1	Spacer
23 (B320-80)	2	Ball Bearing
23A (B320-80)	1	Ball Bearing
24	1	O-ring
25	A/R	Shim
26	1	Key
27	4	Lockwasher
28	4	Hex Head Cap Screw
29	1	Circlip
43 (B320-80)	1	Washer
52	1	Motorized Adapter
53	1	Lockwasher
54	1	Hex Head Cap Screw
56 (B320-50)	1	Spacer Ring (not shown)
61 (B320-20, -40, -50, -70)	1	O-ring

Note: A/R—as required

6.2 Disassembly and Reassembly of B320-90

6.2.1 Disassembly

(Piece numbers refer to Figure 6.5).

1. Remove Thrust Plate (piece #118) followed by Stem Nut (piece #392, two-piece) and Drive Sleeve (piece #117, 2-piece; piece #394, one-piece) and Roller Bearings (piece #115 and 116).
2. Remove Bevel Cap (piece #94) and withdraw Bevel Pinion/Bearing Subassembly (piece #95, #103 and #104).
3. Remove Bevel Housing (piece #91) from Thrust Housing (piece #114).
4. Remove Bevel Gear/Torque Drive Sleeve subassembly (piece #93 and 96) and Ball Bearings (piece #102).

6.2.2 Reassembly

(Piece numbers refer to Figure 6.5).

1. Install Ball Bearings (piece #102) and Bevel Gear/Torque Drive Sleeve subassembly (piece #93 and 96).
2. Attach Bevel Housing (piece #91) to Thrust Base (piece #114).
3. Attach Bevel Cap (piece #94) and Bevel Pinion/Bearing Subassembly (piece #95, #103 and #104).
4. Install Roller Bearings (piece #115 and 116) and Stem Nut (piece #392, two-piece) and Drive Sleeve (piece #117, two-piece; piece #394, one-piece), followed by Thrust Plate (piece #118).

Figure 6.5 – B320-90 Parts Diagram

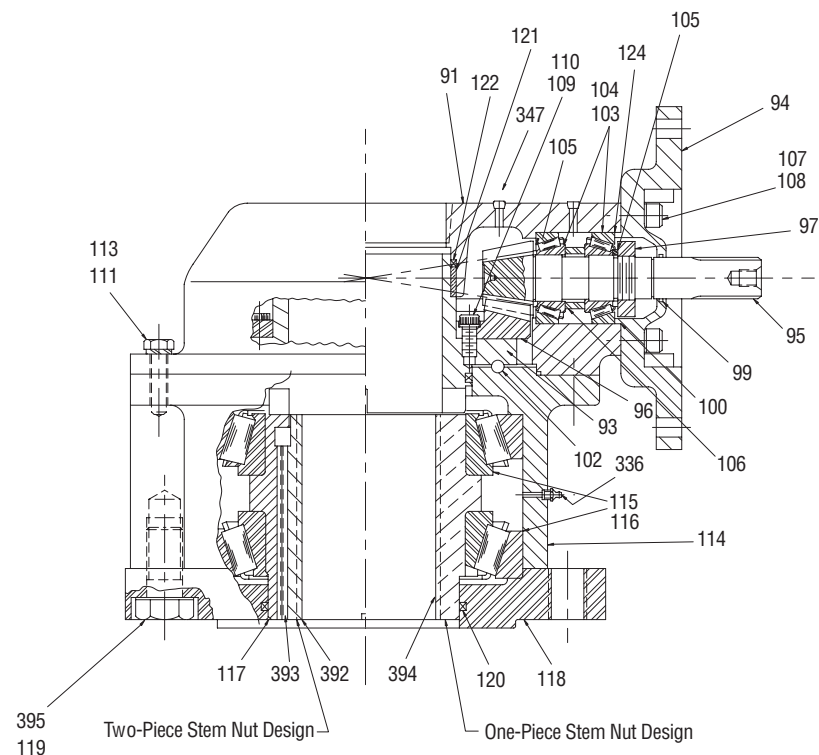

Table 6.3 – B320-90 Parts List

Piece	Quantity	Description
91	1	Bevel Housing
93	1	Torque Drive Sleeve
94	1	Bevel Cap
95	1	Input Shaft/Pinion
96	1	Bevel Gear
97	1	Threaded Collar
99	1	Quad Ring
100	1	O-ring
102	66	Ball Bearing
103	2	Roller Bearing Cone
104	2	Roller Bearing Cup
105	2	Spacer-Pinion
106	1	Spacer-Input Bearing
107	6	Hex Head Cap Screw
108	6	Lockwasher
109	12	Soc Head Cap Screw
110	12	Lockwasher
111	6	Hex Head Cap Screw
113	6	Lockwasher
114	1	Thrust Housing
115	2	Roller Bearing Cone
116	2	Roller Bearing Cup
117	1	Thrust Drive Sleeve (2-pc)
118	1	Thrust Plate
119	8	Hex Head Cap Screw
120	1	Quad Ring
121	1	Bushing
122	1	Quad Ring
336	1	Grease Fitting
347	1	Pipe Plug
392	1	Stem Nut
393	1	Key
394	1	Thrust Drive Sleeve (1-pc)
395	1	Lockwasher

6.3 Disassembly and Reassembly of Spur Gear Attachments

6.3.1 Disassembly of 3:1 Spur Gear Attachment for B320-10 through -40

(Piece numbers refer to Figure 6.6 and Table 6.4).

1. Remove Hex Head Cap Screws(piece #34) and Lockwashers (piece #35).
2. Remove the Spur Gear Cover (piece #31) and O-ring (piece #46), followed by the Input Shaft and Pinion (piece #37), Idler Gear (piece #38), and Output Gear (piece #40).

3. Remove the Snap Ring (piece #29).
4. Remove the Hex Head Cap Screw (piece #28) and Lockwasher (piece #27).
5. Remove the Spur Gear Housing (piece #30).
6. Continue disassembly as detailed in Section 6.1. Disassembly and Reassembly – 320-10 through -80.

6.3.2 Reassembly of 3:1 Spur Gear Attachment for B320-10 through -40

(Piece numbers refer to Figure 6.6 and Table 6.4).

1. Install the Spur Gear Housing (piece #30), using the Hex Head Cap Screw (piece #28) and Lockwashers (piece #27).
2. Install the Snap Ring (piece #29).
3. Install the Output Gear (piece #40), Idler Gear (piece #38), and Input Shaft and Pinion (piece #37).
4. Install the O-ring (piece #46) and Spur Gear (piece #31), using the Hex Head Cap Screws (piece #34) and Lockwashers (piece #35)

Figure 6.6 – 3:1 SGA Parts Diagram for B320-10 through -40

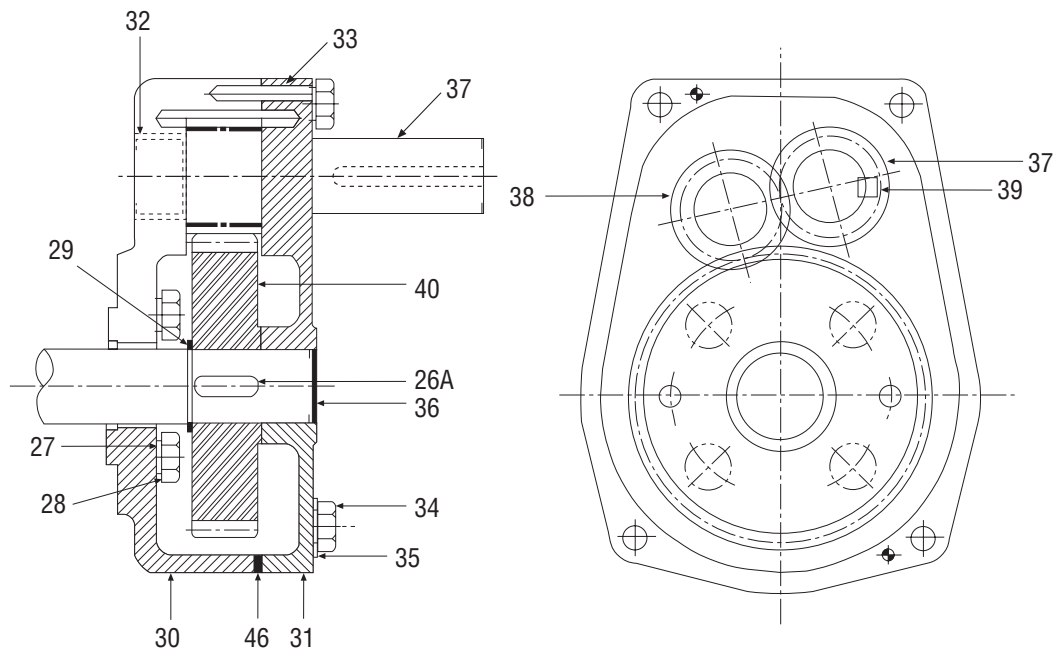

Table 6.4 – 3:1 SGA Parts List for B320-10 through -40

Piece	Quantity	Description
26A	1	Key
27	4	Lockwasher
28	4	Hex Head Cap Screw
29	1	Snap Ring
30	1	Spur Gear Housing
31	1	Spur Gear Cover
32	5	Bushing
33	2	Dowel Pin
34	4	Hex Head Cap Screw
35	4	Lockwasher
36	2	Expansion Plug
37	1	Input Shaft and Pinion
38	1	Idler Gear
39	1	Key
40	1	Output Gear
46	1	O-ring

6.3.3 Disassembly of 6.3:1, 10.3:1, and 10.8:1 Spur Gear Attachments for B320-50, -70, and -80

(Piece numbers refer to Figure 6.7 and Table 6.5).

1. Remove the Hex Head Cap Screws (piece #47) and Lockwashers (piece #35).
2. Remove the End Cover (piece #44) and O-ring (piece #46), followed by the Input Shaft and Pinion (piece #37) and outer Ball Bearing (piece #45).
3. Remove the Hex Head Cap Screw (piece #34) and Lockwasher (piece #35).
4. Remove the Spur Gear Cover (piece #31), followed by the Idler Shaft subassembly (piece #48), inner Ball Bearing (piece #45), and Final Gear (piece #40).
5. Remove the Socket Head Cap Screws (piece #53) and Lockwashers (piece #54).
6. Remove the Spur Gear Housing (piece #30).
7. Continue disassembly as detailed in Section 6.1, Disassembly and Reassembly of B320-10 through -80.

6.3.4 Reassembly of 6.3:1, 10.3:1, and 10.8:1 Spur Gear Attachments for B320-50, -70, and -80

(Piece numbers refer to Figure 6.7 and Table 6.5).

1. Install the Spur Gear Housing (piece #30), using the Socket Head Cap Screws (piece #53) and Lockwashers (piece #54).
2. Install the Final Gear (piece #40), inner Ball Bearings (piece #45), Idler Shaft subassembly (piece #48), and the Spur Gear Cover (piece #31).
3. Install the Spur Gear Cover (piece #31), using the Hex Head Cap Screws (piece #34) and Lockwashers (piece #35).
4. Install the outer Ball Bearing (piece #45) and Input Shaft and Pinion (piece #37).
5. Install the O-ring (piece #46) and End Cover (piece #44), using the Hex Head Cap Screws (piece #47) and Lockwashers (piece #35).

Figure 6.7 – 6.3:1, 10.3:1, and 10.8:1 SGA Parts Diagram for B320-50 through -80

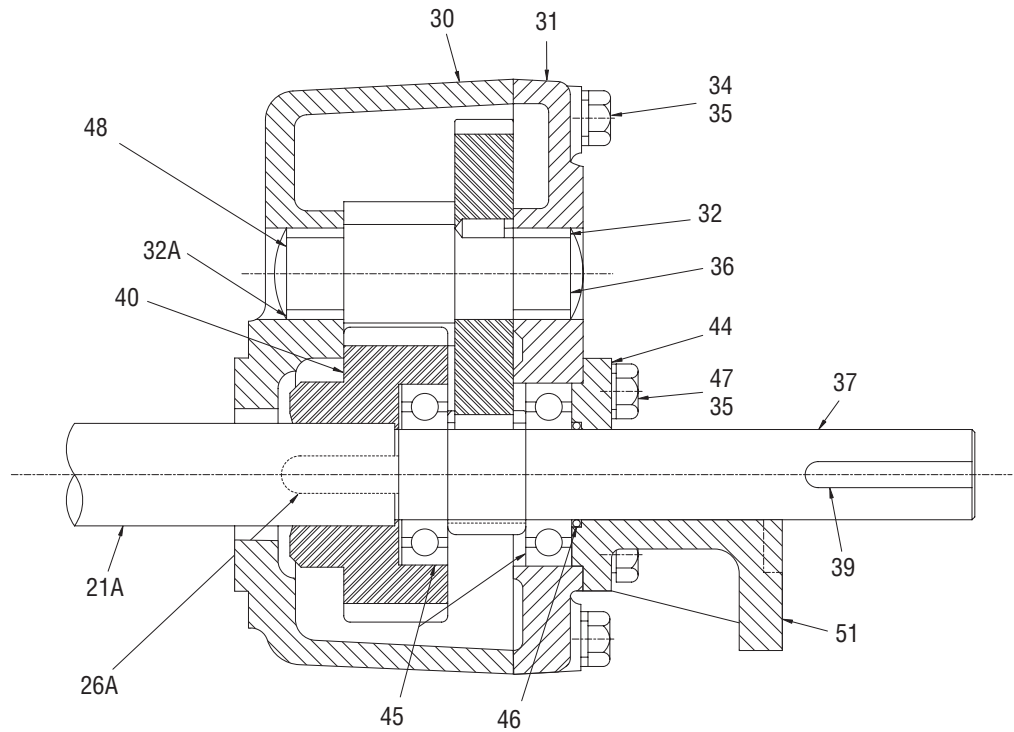

Table 6.5 – 6.3:1, 10.3:1, and 10.8:1 SGA Parts List for B320-50 through -80

Piece	Quantity	Description
21A	1	Spur Pinion
26A	2	Key
30	1	Spur Gear Housing
31	1	Spur Gear Cover
32	1	Bushing
32A	1	Bushing
33	2	Dowel Pin (not shown)
34	8	Hex Head Cap Screw
35	12	Lockwasher
36	2	Plug
37	1	Input Shaft & Pinion
39	1	Key
40	1	Final Gear
44	1	Endcover
45	2	Ball Bearing
46	1	O-ring
47	4	Hex Head Cap Screw
48	1	Idler Shaft Subassembly
51	1	Motorized Adapter (if required)
53	8	Socket Head Cap Screw (internal, not shown)
54	8	Lockwasher (Hi Collar) (internal, not shown)

6.3.5 Disassembly of 5:1 Spur Gear Attachment for B320-90

(Piece numbers refer to Figure 6.8 and Table 6.6).

1. Remove the Socket Head Cap Screws (piece #217) and Lockwashers (piece #216) to remove the Housing (piece #201).
2. Remove the Housing complete with the Input Shaft and Pinion (piece #202) and Idler Gear (piece #203).
3. Remove the Hex Head Cap Screw (piece #215), Lockwasher (piece #214), and Flat Washer (piece #213).
4. Remove the Output Gear (piece #204).
5. Remove the Hex Head Cap Screw (piece #218) and Lockwasher (piece #216).
6. Remove the Adapter Plate (piece #200) and O-ring (piece #211).
7. Continue disassembly as detailed in Section 6.1, Disassembly and Reassembly of B320-90.

6.3.6 Reassembly of 5:1 Spur Gear Attachment for B320-90

(Piece numbers refer to Figure 6.8 and Table 6.6).

1. Install the O-ring (piece #211) and Adapter Plate (piece #200), using the Hex Head Cap Screws (piece #218) and Lockwashers (piece #216).
2. Install the Output Gear (piece #204).
3. Install the Flat Washer (piece #213), Lockwasher (piece #214), and Hex Head Cap Screw (piece #215).
4. Install the Idler Gear (piece #203) and the Input Shaft and Pinion (piece #202) into the Housing (piece #201).
5. Apply liquid gasket to the Adapter Plate flange and install the Housing assembly (piece #210, #202, and #203), using the Socket Head Cap Screws (piece #217) and Lockwashers (piece #216).

Figure 6.8 – 5:1 SGA Parts Diagram for B320-90

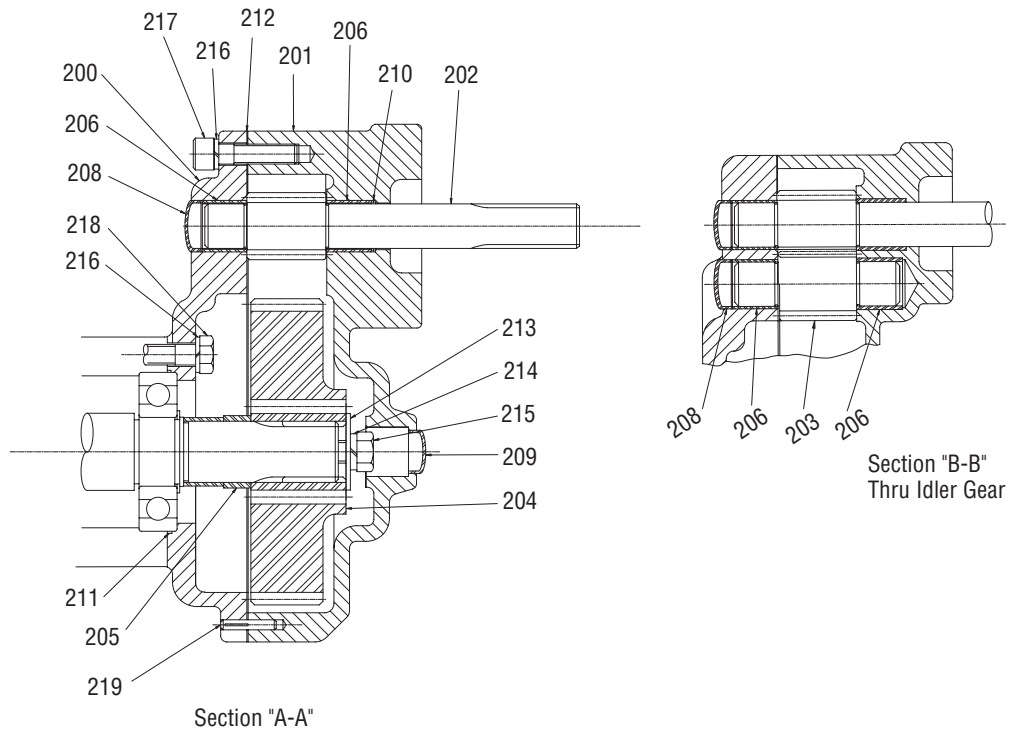

Table 6.6 – 5:1 SGA Parts List for B320-90

Piece	Quantity	Description
200	1	Adapter Plate
201	1	Housing
202	1	Input Shaft and Pinion
203	1	Idler Gear
204	1	Output Gear
205	1	Spacer
206	4	Teflon Bearing
208	2	Expansion Plug
209	1	Expansion Plug
210	1	Quad Ring
211	1	O-ring
212	1	Gasket
213	1	Flat Washer
214	1	Lockwasher
215	1	Hex Head Cap Screw
216	13	Lockwasher
217	7	Socket Head Cap Screw
218	6	Hex Head Cap Screw
219	2	Dowel Pin
347	1	Pipe Plug (not shown)

6.3.7 Disassembly of 17.5:1 Spur Gear Attachment for B320-90

(Piece numbers refer to Figure 6.9 and Table 6.7).

1. Remove Socket Head Cap Screws (piece #220) and Lockwashers (piece #221) to remove the Housing Cover (piece #201). The Input Shaft and Pinion (piece #202, 207, 208 and 211) are removed with the Housing Cover (piece #201).

NOTE: If the Input Shaft is horizontal, exercise caution when removing the Housing Cover. Prepare to support the 2nd Set Input Shaft Assembly (piece# 204, #205, and #206)

2. Remove the 1st Set Output Gear (piece #203), the 2nd Set Input Shaft (piece #204), and the 2nd Set Input Gear (piece #205).
3. Remove the Socket Head Screw (piece #218), Lockwasher (piece #217), and the Flat Washer (piece #216).
4. Remove the 2nd Set Output Gear (piece #206).
5. Remove the Hex Head Cap Screw (piece #222) and Lockwashers (piece #223), and remove the Housing (piece #200) and O-ring (piece #212).
6. Continue disassembly as detailed in Section 6.2, Disassembly & Reassembly – B320-90.

6.3.8 Reassembly of 17.5:1 Spur Gear Attachment for B320-90

(Piece numbers refer to Figure 6.9 and Table 6.7).

1. Install O-ring (piece #212) and Housing (piece #200) using the Hex Head Cap Screws (piece #222) and Lockwashers (piece #223).
2. Install the 2nd Set Output Gear (piece #206).
3. Install the Flat Washer (piece #216), Lockwasher (piece #217), and Socket Head Cap Screws (piece #218).
4. Install the 2nd Set Input Gear (piece #205), 2nd Set Input Shaft (piece #204), and 1st Set Output Gear (piece #203).
5. Apply liquid gasket to the flange surface of the Housing (piece #200), and install the Housing Cover (piece #201) using Lockwashers (piece #221) and Socket Head Cap Screws (piece #220).

Figure 6.9 – 17.5:1 SGA Parts Diagram for B320-90

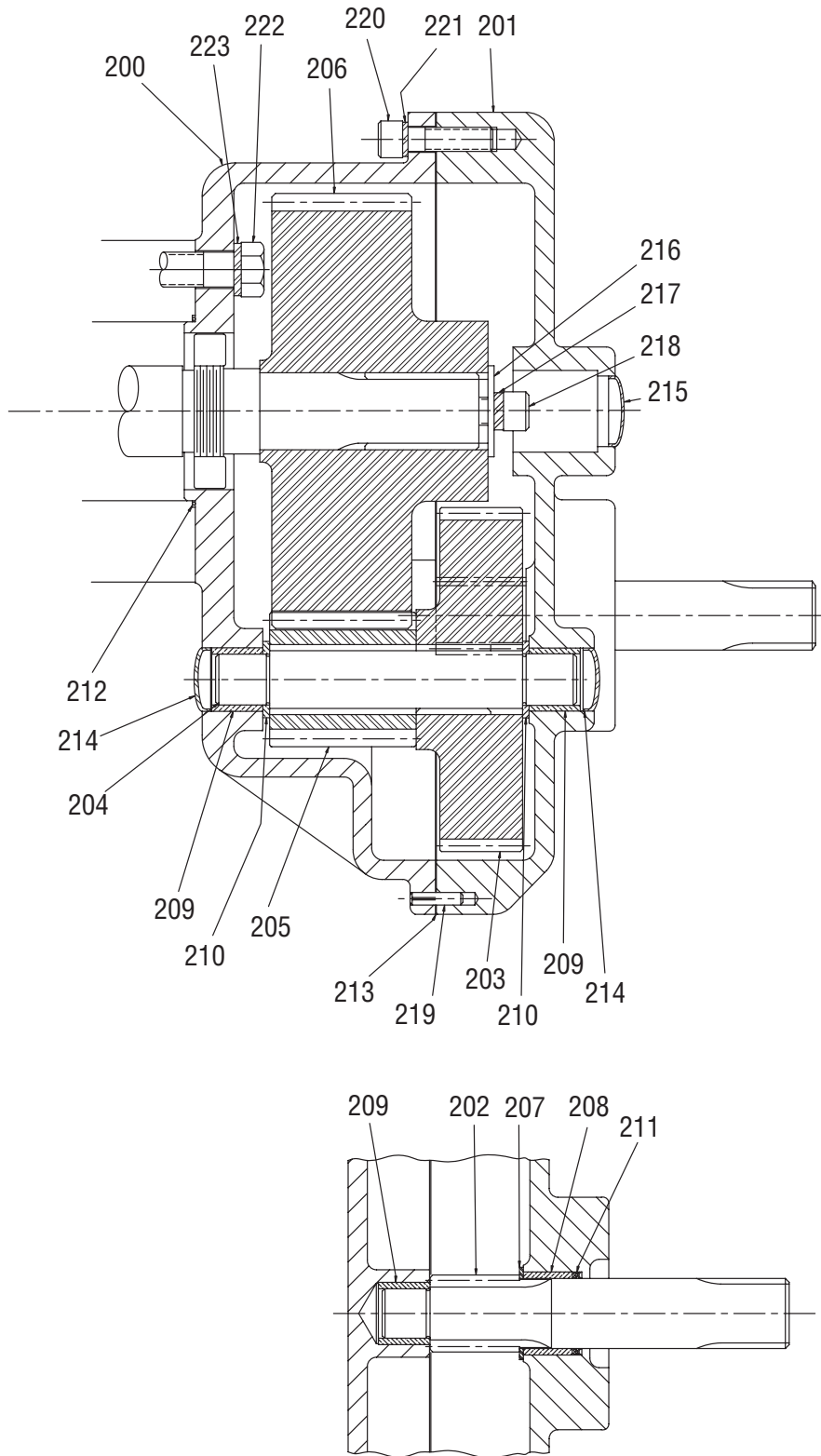

Table 6.7 – 17.5:1 SGA Parts List for B320-90

Piece	Quantity	Description
200	1	Housing
201	1	Housing Cover
202	1	1st Set Input Shaft/Pinion
203	1	1st Set Output Gear
204	1	2nd Set Input Shaft
205	1	2nd Set Input Gear
206	1	2nd Set Output Gear
207	1	Spacer
208	1	Bushing
209	3	Bushing
210	2	Thrust Washer
211	1	Quad Ring
212	1	O-ring
213	1	Gasket
214	2	Expansion Plug
215	1	Expansion Plug
216	1	Flatwasher
217	1	Lockwasher
218	1	Socket Head Cap Screw
219	2	Dowel Pin
220	8	Socket Head Cap Screw
221	8	Lockwasher
222	6	Hex Head Cap Screw
223	6	Lockwasher
347	1	Pipe Plug (not shown)

7

How to Order Parts

To order parts or obtain further information for your Limitorque B320 gear operators, contact your local Limitorque distributor sales office, or:

Flowserve Flow Control
Limitorque Actuation Systems
5114 Woodall Road
P.O. Box 11318
Lynchburg, VA 24506-1318

Telephone 434 528 4400
Fax 434 845 9736
www.flowserve.com/valves

All inquiries or orders must be accompanied by the following information:

1. Actuator Size
2. Limitorque Order Number
3. Limitorque Serial Number

This page is left intentionally blank.



**Flowserve Corporation
Flow Control**

United States

Flowserve Limatorque
5114 Woodall Road
P.O. Box 11318
Lynchburg, VA 24506-1318
Phone: 434-528-4400
Fax: 434-845-9736

England

Flowserve Limatorque
Euro House
Abex Road
Newbury
Berkshire, RG14 5EY
United Kingdom
Phone: 44-1-635-46999
Fax: 44-1-635-36034

Singapore

Limatorque Asia, Pte., Ltd.
12, Tuas Avenue 20
Singapore 638824
Phone: 65-6868-4628
Fax: 65-6862-4940

China

Limatorque Beijing, Pte., Ltd.
RM A1/A2
22/F, East Area, Hanwei Plaza
No. 7 Guanghua Road, Chaoyang
District
Beijing 100004, Peoples Republic
of China
Phone: 86-10-5921-0606
Fax: 86-10-6561-2702

India

Flowserve Limatorque
Plot No. #4, 1 A, Road No. 8, EPIP
Whitefield, Bangalore – 560066
Karnataka
India
Phone: 91-80-40146200
Fax: 91-80-28410286

Italy

Flowserve Limatorque
Fluid Power Systems
Via Rio Vallone 17
20883 Mezzago MB
Italy
Phone: 39-039-620601
Fax: 39-039-62060 213

FCD LMENIM3201-02-AQ Printed in USA. January 2015

**To find your local Flowserve representative,
visit www.flowserve.com or call USA 1 800 225 6989**

Flowserve Corporation has established industry leadership in the design and manufacture of its products. When properly selected, this Flowserve product is designed to perform its intended function safely during its useful life. However, the purchaser or user of Flowserve products should be aware that Flowserve products might be used in numerous applications under a wide variety of industrial service conditions. Although Flowserve can (and often does) provide general guidelines, it cannot provide specific data and warnings for all possible applications. The purchaser/user must therefore assume the ultimate responsibility for the proper sizing and selection, installation, operation, and maintenance of Flowserve products. The purchaser/user should read and understand the Installation Operation Maintenance (IOM) instructions included with the product, and train its employees and contractors in the safe use of Flowserve products in connection with the specific application.

While the information and specifications contained in this literature are believed to be accurate, they are supplied for informative purposes only and should not be considered certified or as a guarantee of satisfactory results by reliance thereon. Nothing contained herein is to be construed as a warranty or guarantee, express or implied, regarding any matter with respect to this product. Because Flowserve is continually improving and upgrading its product design, the specifications, dimensions and information contained herein are subject to change without notice. Should any question arise concerning these provisions, the purchaser/user should contact Flowserve Corporation at any one of its worldwide operations or offices.

© 2015 Flowserve Corporation, Irving, Texas, USA. Flowserve is a registered trademark of Flowserve Corporation.