



## SIHI® LPG Pumping Solutions



*Experience In Motion*



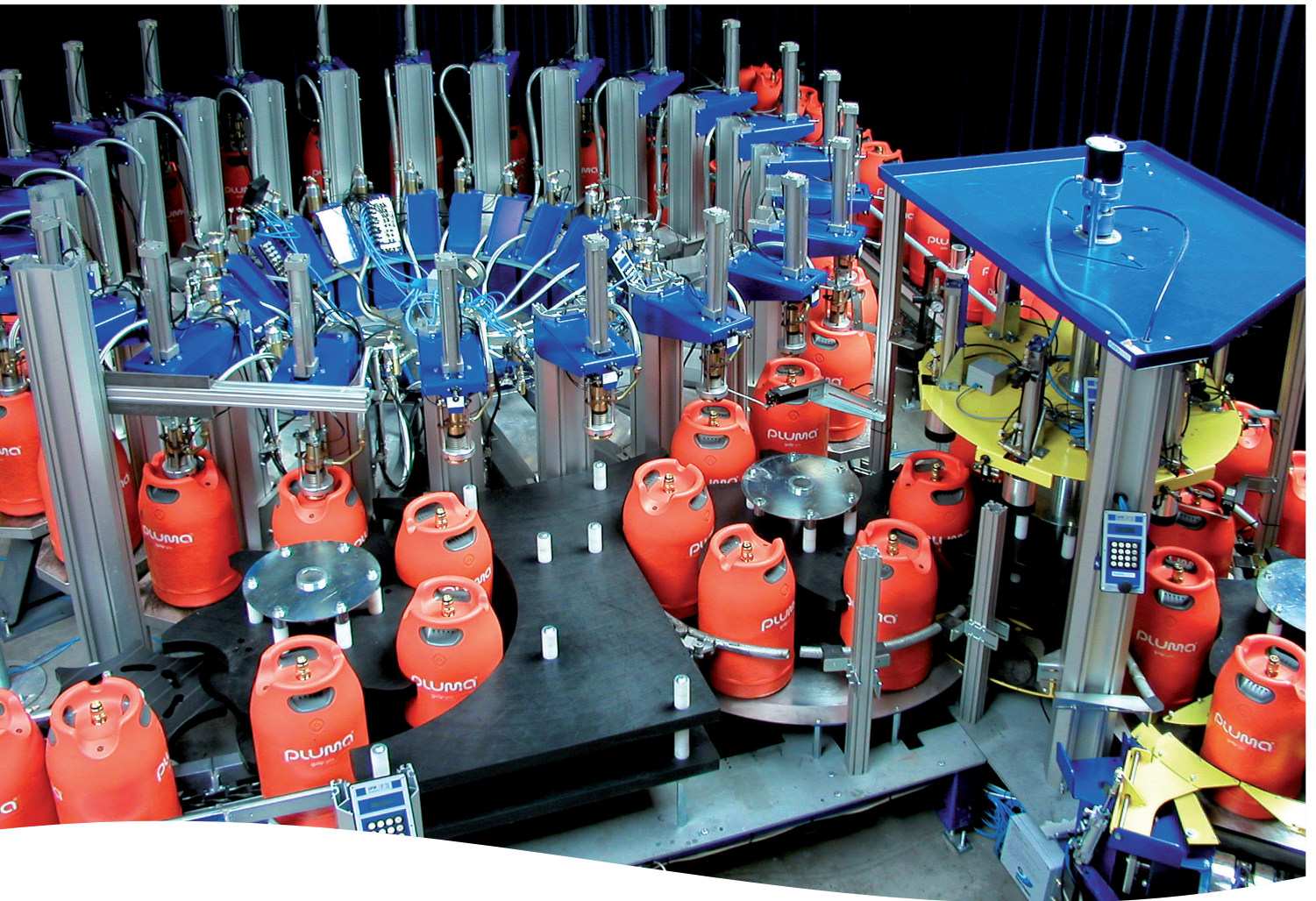

## Designed to perform

Liquefied gases vary in terms of their industrial and domestic uses, as well as the way in which they are produced. Liquefied gases, as defined by DIN 51622, include media such as propane, butane and their derivatives. However, liquefied gases also include others such as carbon dioxide, ammonia and other refrigerant-based components.

Storage, transportation and pumping of such liquefied gases are the keys to successfully handling this media. It is vital that the difference between this set of fluids, when compared to conventional media, is fully understood when specifying equipment. In simple terms, an explosive liquid being pumped at its boiling point needs to be handled with greater care than a less complex liquid far away from its vapor pressure.

When specifying pumping equipment, the user or specifier needs to consider long-term, trouble-free operation and ownership. Primarily, the most crucial point pivots around the vapor pressure of the liquefied gas.





## Key design features of SIHI LPG pumps

- Low NPSH
- High-pressure generation
- Steep pressure-to-flow curve
- Gas handling
- Easy handling
- Safe and easy operation
- Easy maintenance
- Safe working in explosion-proof environment
- Comply with global standards of explosion-proof design

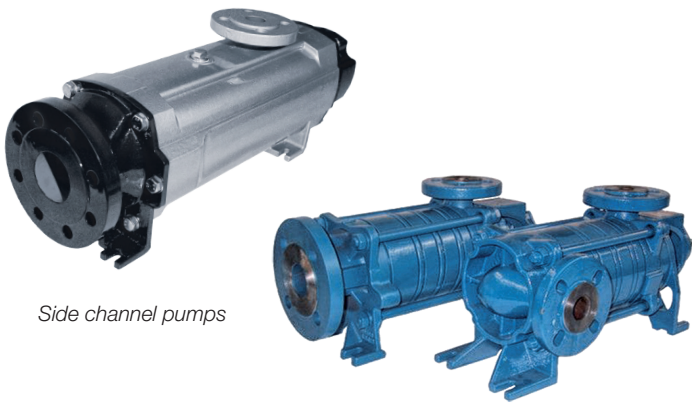

*Side channel pumps*



*Submersible pumps*



*Vertical tank pumps*



*Multistage pumps*

## Solutions for LPG car filling



### CEB vertical tank pumps

Magnetic coupled pumps installed at the top of the underground storage tank with a maximum diameter of 6 m (19.7 ft).

### SM-X submersible pumps

The new submersible SIHI pump combines side channel technology and all the benefits of a canned motor. The pumps are designed to operate under the most severe conditions without any possible risks. The canned motor of the submersible SIHI pump eliminates all maintenance and possible leakage.

### PC-X side channel pumps

The PC-X pump is a new generation of LPG pumps offering a wide range of benefits for the OEM and fuel station. By combining the side channel with an intelligent drive, we have eliminated all possible risk of leaking, misalignment and difficulties during startup. The combination also reduces cost of ownership and minimizes maintenance requirements.

### CEH and SC side channel pumps

Side channel pumps with a special low-NPSH centrifugal impeller stage have self-priming characteristics, which allow them to accommodate entrained gas with ease.

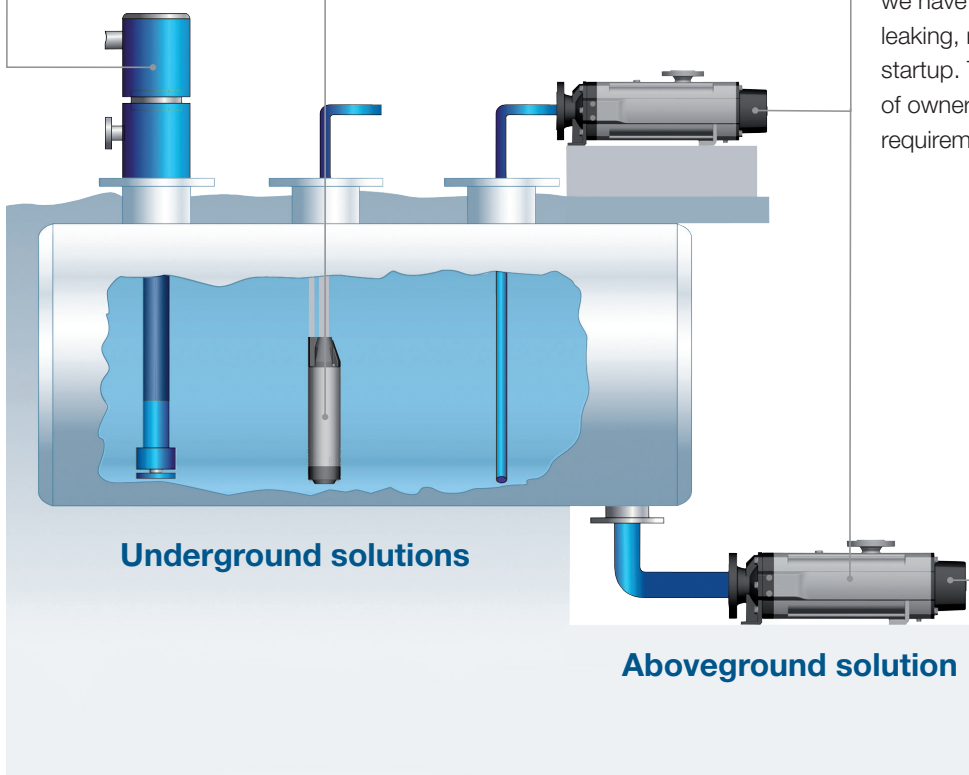



## Solutions for LPG transfer and bottle filling

### UEA

Multistage pumps with a special set of low-NPSH centrifugal impellers, integrated with a single gas handling and priming stage, are used for high-flow applications. With flooded suction, these units are typically used for tanker (off) loading, transfer and bulk storage. The UEA incorporates a priming stage (integral side channel stage), which prevents vapor locking and facilitates self-priming of the pump.

### CEH

Side channel pumps with a special low-NPSH centrifugal impeller stage have self-priming characteristics which accommodate entrained gas with ease.

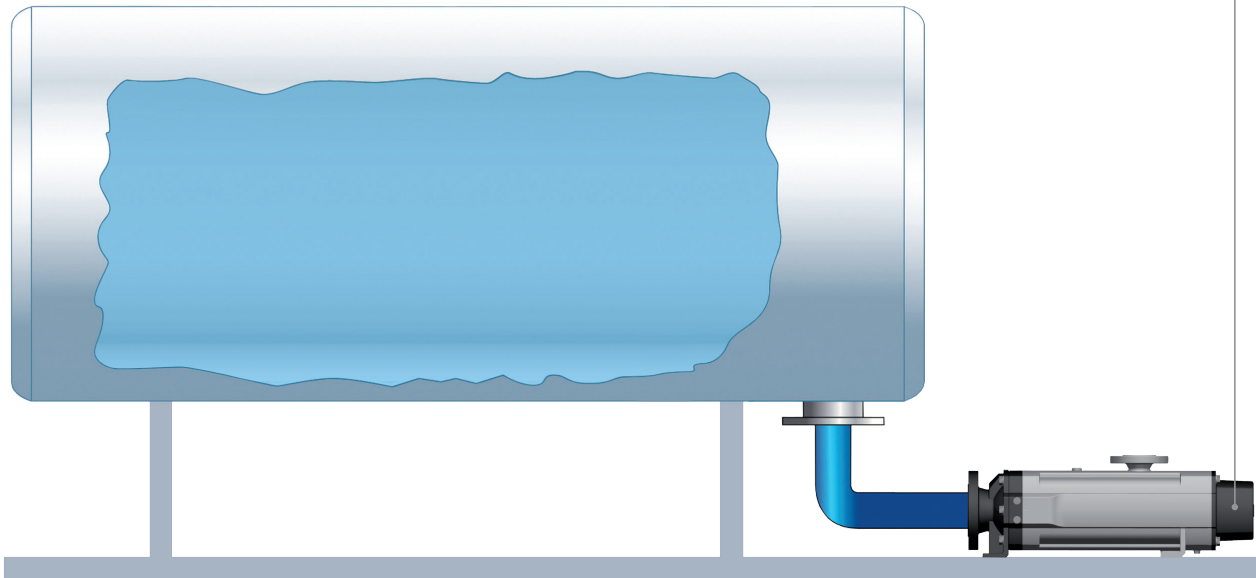

# PC-X side channel pumps

The new SIHI PC-X pumps offer a wide range of benefits for the OEM and fuel station. With our new side channel pump technology combined with the new electronic drive, we have eliminated all possible risk of leaking, misalignment and difficulties during startup. We have also reduced the costs of ownership and maintenance to a very low level due to the fact that there is no need of service liquid to operate the pump, there is no mechanical seal, and that the pump knows how to manage dry running.

The new pump controls itself and is able to deliver easily a classical duty point like 8 bar at 60 l/min for one to two dispensers. In addition to this energy-friendly pump design, all possible safeties are integrated to guarantee a safe and secure operation in all climate conditions. The complete design is ATEX and IECEx approved.

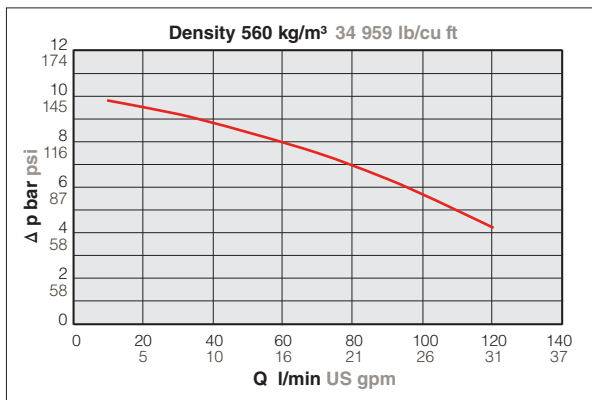

Technical data	PC-X
Output max.	120 l/min (31 US gpm)
Differential pressure	Max. 10 bar (145 psi)
Speed max.	Variable speed
Temperature	-30°C to 50°C (-22°F to 122°F)
Casing pressure	PN 25
Shaft sealing	Sealless canned motor

## NPSH impeller

- Higher tank capacity

## Same flange connection

- Interchangeable

## Side channel technology

- Steep performance curve
- Gas-handling capability

## Same footprint

- Interchangeable

## Canned motor design

- Highest safety
- No sealings

## Intelligent board

- Dry priming
- Power saving
- Easy installation

## Internal cooling

- Continuous operation

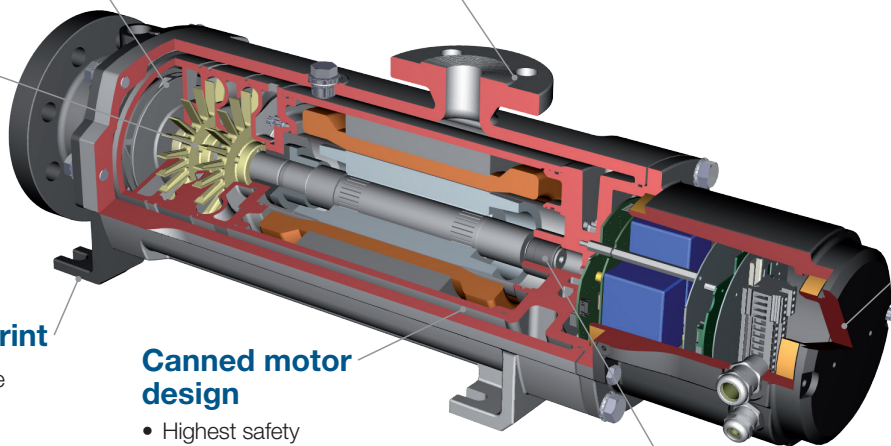



# SM-X submersible pumps

The new SIHI SM-X submersible pump uses the highly renowned side channel technology with all the features and benefits of a normal side channel pump. The submersible pump features a canned motor design, which means no maintenance and possible leakage. The SM-X can deliver LPG to two dispensers and operates at 50- and 60-cycle networks. Its design is ATEX and IECEx approved.

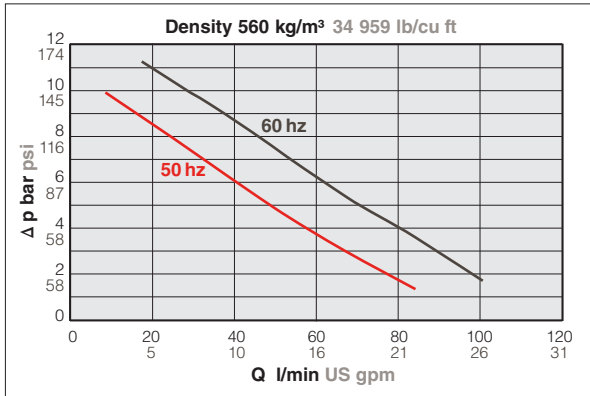

Technical data	SM-X
Output max.	100 l/min (26 US gpm)
Differential pressure	Max. 10 bar (145 psi)
Speed max.	3400 rpm
Temperature	-20°C to 40°C (-4°F to 104°F)
Casing pressure	PN 25
Shaft sealing	Sealless canned motor

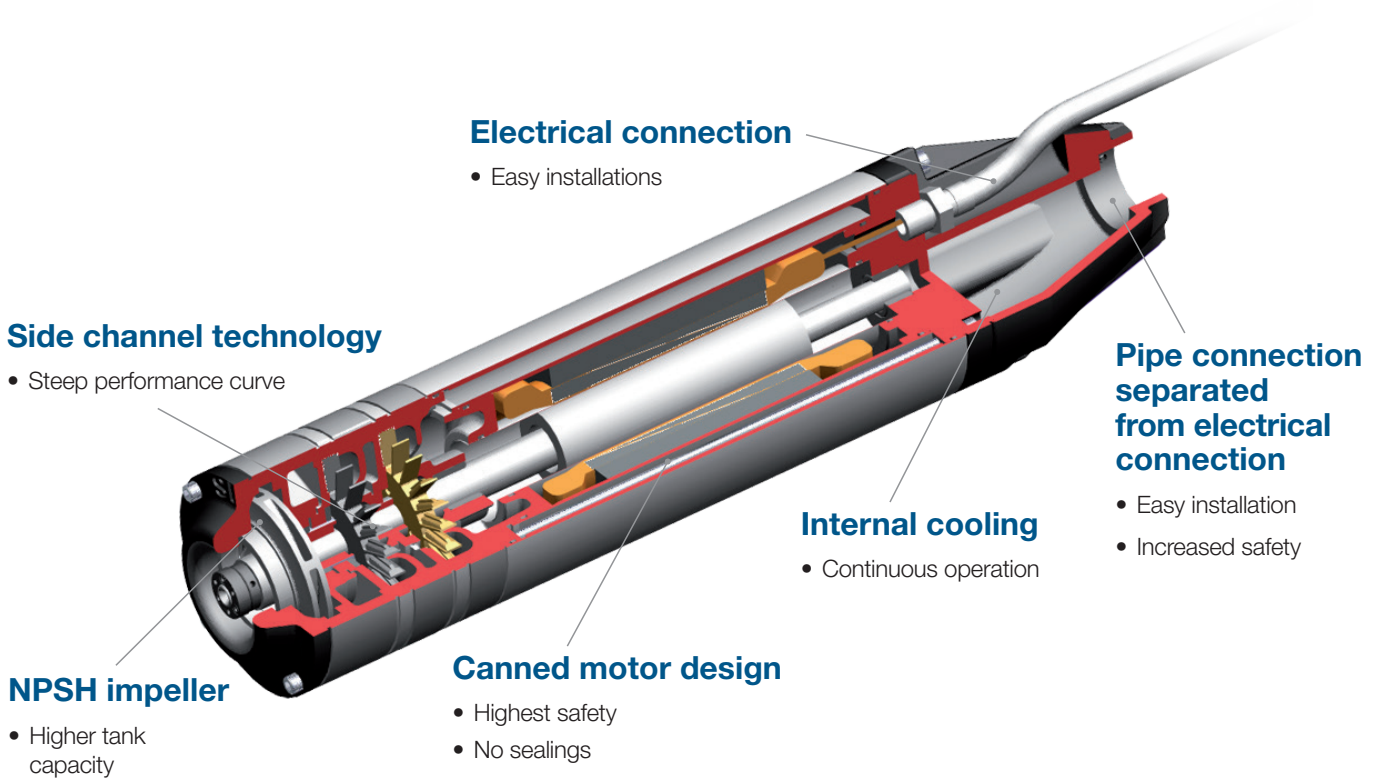

# CEH and SC side channel pumps

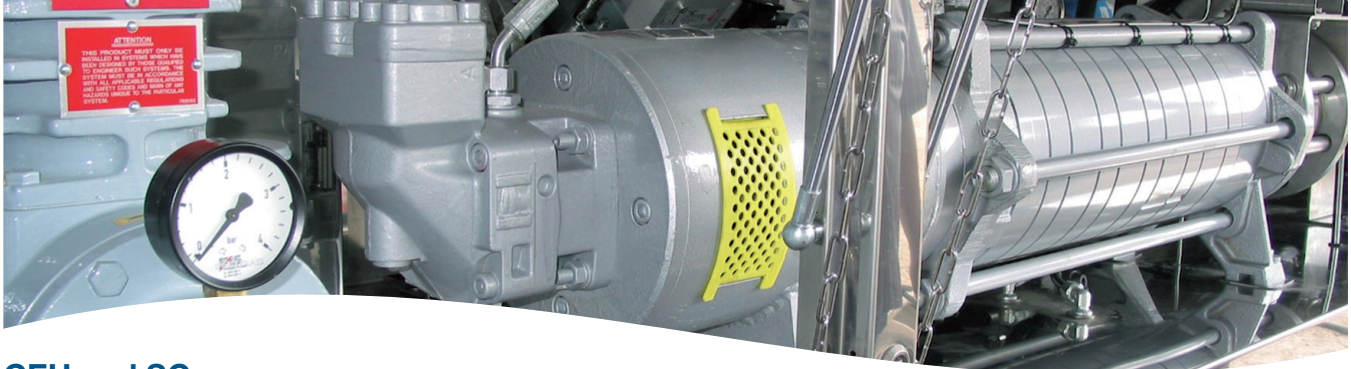

## CEH and SC

The most common combination pump design is of horizontal construction with ring-section multistages and an inline axial suction branch for reduced entry losses. In both the CEH and SC SIHI pump models, an oversized centrifugal impeller is mounted downstream of a flow-harmonizing, extended suction branch. The flow-harmonizing suction branch, together with oversized centrifugal impeller, meets the low-NPSH requirement while extending hydraulic efficiency.

The latter, downstream side channel stage(s) give the pumps vapor, gas and mixed-flow capabilities along with a high discharge pressure. Moreover, the side channel design is inherently a self-priming design.

Compared with other types of pump technologies, these side channel combination pumps offer users incredibly low-suction inlet conditions. NPSH requirements below 0.2 m can even be reached in certain conditions. For the biggest pump sizes, the flow rate can provide to 35 m<sup>3</sup>/h (154 US gpm).

This results in a simplified installation where costs are optimized. With either pump, there is no need to excavate the pump foundation or increase the vessel height. While the side channel stages are oriented in-line with the initial centrifugal stage, this construction ensures that flow is not interrupted or reduced with partial vaporization.

A design with a hydraulic motor has been especially created for truck offloading.

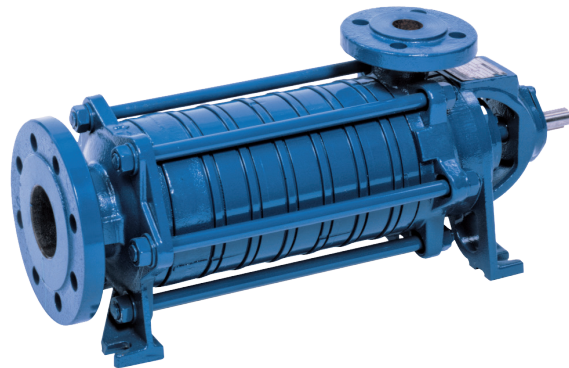

Technical data	CEH	SC
Output max.	580 l/min (153 US gpm)	67 l/min (18 US gpm)
Differential pressure	Max. 40 bar (580 psi)	Max. 14.5 bar (210 psi)
Speed max.	1800 rpm	2900 rpm
Temperature	-20°C to 60°C (-4°F to 140°F)	-20°C to 60°C (-4°F to 140°F)
Casing pressure	PN 40	PN 40
Shaft sealing	Single or double mechanical seal, sealless magnetic coupling	Single mechanical seal



# CEB vertical and UEA multistage pumps

## CEB

Storage tanks with diameters which generally do not exceed 6 m (19.7 ft) can be fitted with vertical tank pumps that have an externally mounted motor. These pumps are mounted on the top flange of the tank with the hydraulic end submerged within the liquid.

The orientation is very similar to the CEH side channel combination pump mounted vertically. The flow-harmonizing hydraulic suction and oversized centrifugal impeller are positioned nearest to the bottom of the inner tank by means of an extension tube. The benefit of this configuration centers upon the hydraulic being in a flooded suction condition.



## UEA

In order to facilitate higher flow rates of liquefied gases, in the region of 200 m<sup>3</sup>/h (880 US gpm), more multistage centrifugal stages can be added. When the balance of stages becomes weighted to a greater number of centrifugal-type impellers, this is known as a *combination pump design*.

Centrifugal combination pumps continue to employ the benefits of the side channel stage, which is mounted downstream of the other impellers toward the discharge.

Consequently, large flows can be pumped very efficiently with the added benefits of self-priming and gas/vapor handling. This pump design features the same design of flow-harmonizing axial inlet, and specially developed first (low) NPSH stage.

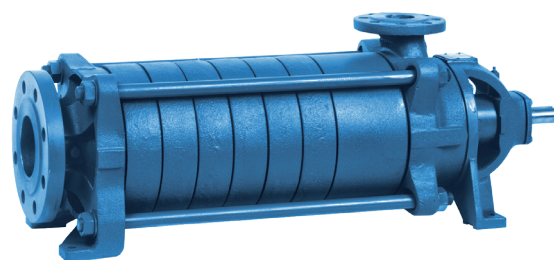

Technical data	CEB	UEA
Output max.	65 l/min (17 US gpm)	3700 l/min (977 US gpm)
Differential pressure	Max. 15 bar (217 psi)	Max. 20 bar (290 psi)
Speed max.	2900 rpm	3600 rpm
Temperature	-40°C to 60°C (-40°F to 140°F)	-40°C to 80°C (-40°F to 176°F)
Casing pressure	PN 40	PN 25/PN 40
Shaft sealing	Sealless magnetic coupling	Single or double mechanical seal

## Efficient LPG pumps





During the various stages of distribution, pumps are required to transfer LPG in order to compensate for the pressure losses in the flow process. Under normal atmospheric conditions, liquefied gases would be gaseous. Depending on the temperature at certain pressures, they can be liquefied.

While liquefied gases have unique fluid characteristics, they are best pumped with equipment that is designed specifically for their application. Conventionally, such liquefied gases require a flooded suction in which to give adequate NPSH, and therefore avoid problems.

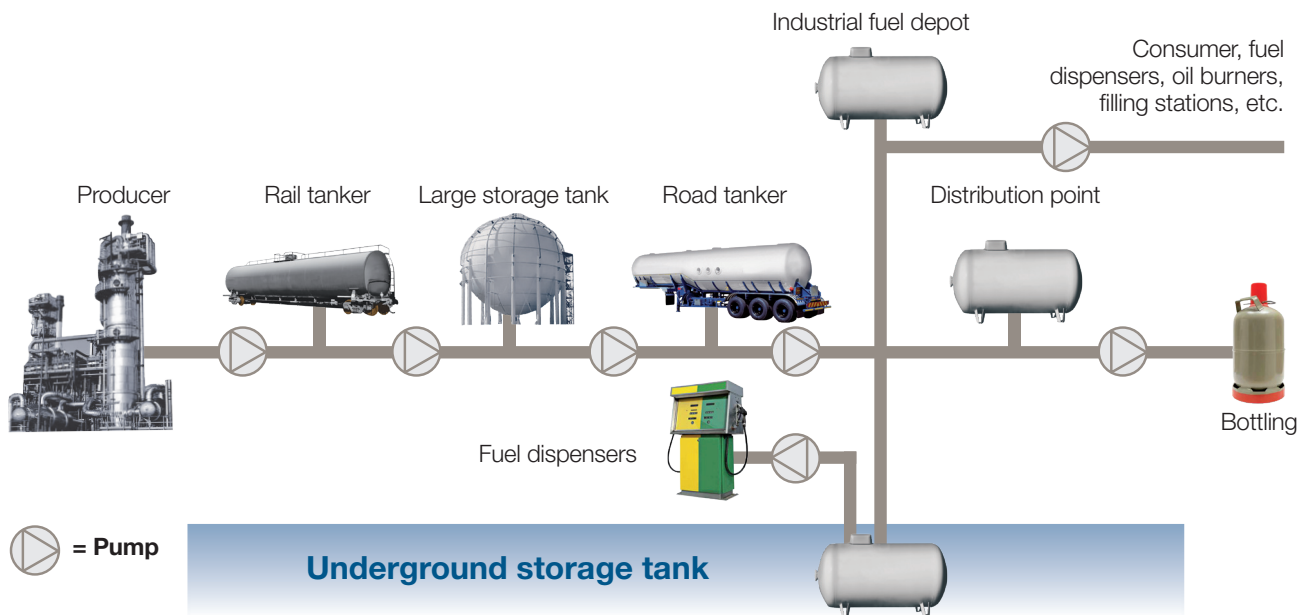



Application		Pump	Installation	
			Underground	Aboveground
Car filling		<b>CEB</b> vertical tank pump	max. 65 l/min (31 US gpm) max. 15 bar (217 psi)	
		<b>SM-X</b> submersible pump	max. 100 l/min (26 US gpm) max. 10 bar (145 psi)	
		<b>PC-X</b> side channel pump	max. 120 l/min (31 US gpm) max. 10 bar (145 psi)	max. 120 l/min (31 US gpm) max. 10 bar (145 psi)
		<b>SC</b> side channel pump		max. 67 l/min (18 US gpm) max. 14.5 bar (210 psi)
Transfer and bottling		<b>UEA</b> multistage pump		max. 3700 l/min (977 US gpm) max. 20 bar (290 psi)
		<b>CEH</b> side channel pump	max. 580 l/min (153 US gpm) max. 40 bar (580 psi)	max. 580 l/min (153 US gpm) max. 40 bar (580 psi)
		<b>PC-X</b> side channel pump	max. 120 l/min (31 US gpm) max. 10 bar (145 psi)	max. 120 l/min (31 US gpm) max. 10 bar (145 psi)



Flowserve Corporation  
5215 North O'Connor Blvd.  
Suite 2300  
Irving, Texas 75039-5421 USA  
Telephone: +1 937 890 5839

Flowserve Corporation has established industry leadership in the design and manufacture of its products. When properly selected, this Flowserve product is designed to perform its intended function safely during its useful life. However, the purchaser or user of Flowserve products should be aware that Flowserve products might be used in numerous applications under a wide variety of industrial service conditions. Although Flowserve can provide general guidelines, it cannot provide specific data and warnings for all possible applications. The purchaser/user must therefore assume the ultimate responsibility for the proper sizing and selection, installation, operation, and maintenance of Flowserve products. The purchaser/user should read and understand the Installation Instructions included with the product, and train its employees and contractors in the safe use of Flowserve products in connection with the specific application.

While the information and specifications contained in this literature are believed to be accurate, they are supplied for informative purposes only and should not be considered certified or as a guarantee of satisfactory results by reliance thereon. Nothing contained herein is to be construed as a warranty or guarantee, express or implied, regarding any matter with respect to this product. Because Flowserve is continually improving and upgrading its product design, the specifications, dimensions and information contained herein are subject to change without notice. Should any question arise concerning these provisions, the purchaser/user should contact Flowserve Corporation at any one of its worldwide operations or offices.

©2018 Flowserve Corporation. All rights reserved. This document contains registered and unregistered trademarks of Flowserve Corporation. Other company, product, or service names may be trademarks or service marks of their respective companies.

**PS-120-2b (A4)** June 2019