



# *USER INSTRUCTIONS*

***LDG Gas Powered Heavy-Duty  
Actuator Series  
Single Acting & Double Acting***

***Installation  
Operation  
Maintenance***

FCD LFENIM0005-00 AQ – 06/16

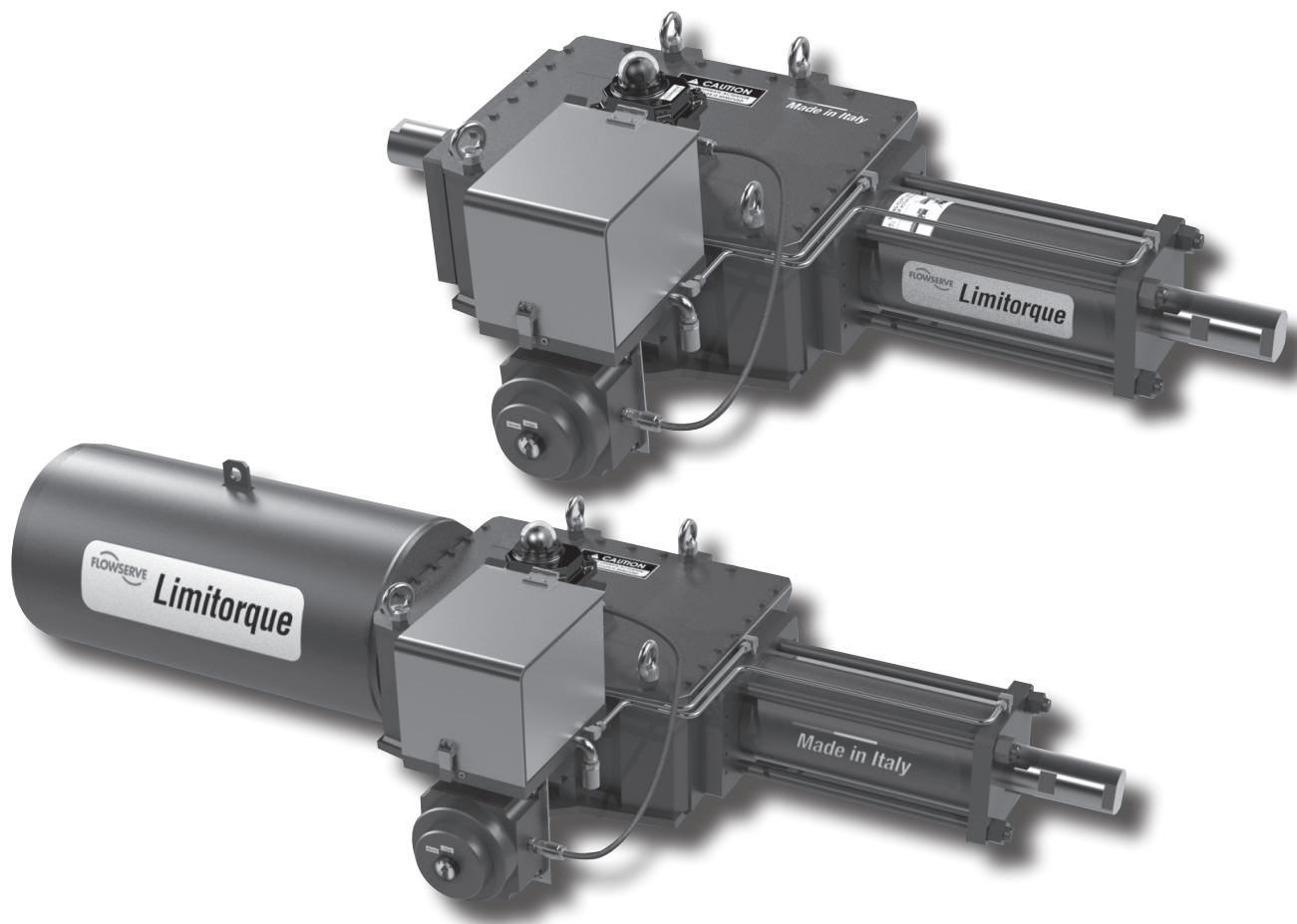

***Experience In Motion***

# Contents

<b>1</b>	<b>Standard Information</b>	<b>4</b>
	Using Flowserve Valves, Actuators and Accessories Correctly	4
1.1	Terms Concerning Safety	4
1.2	General Usage	5
1.3	Protective Clothing	5
1.4	Qualified Personnel	5
1.5	Other Requirements for In-plant Installation	5
1.6	Spare Parts	6
1.7	Service/Repair	6
1.8	Actuator Lifting and Handling	6
1.9	Storage	9
1.10	Valve and Actuator Variations	9
1.11	Unpacking	9
<b>2</b>	<b>Installation Instructions</b>	<b>10</b>
2.1	Valve and Actuator Check	11
2.2	Connection With Valve and Mounting Kit	11
2.3	Travel-stop Bolts and Accessories	12
2.4	Grounding System	12
2.5	Initial Operation	13
2.6	Fail Open and Fail Close Configuration	14
<b>3</b>	<b>Field Conversion</b>	<b>15</b>
3.1	Actuator Disassembled From the Valve	15
3.2	Actuator Connected to the Valve (and the valve can be stroked)	16
<b>4</b>	<b>Maintenance Instructions</b>	<b>18</b>
4.1	General Disassembly Instructions	19
4.2	Spring Container Maintenance	19
4.3	Pneumatic Cylinder Maintenance	21
4.4	Scotch Yoke Housing Maintenance	22
4.5	Spare Parts	23
<b>5</b>	<b>Troubleshooting</b>	<b>24</b>
<b>6</b>	<b>Disposal of Decommissioned Actuators</b>	<b>26</b>
<b>7</b>	<b>Annex</b>	<b>27</b>

# Figures

Figure 1: Lifting Lug for Spring Can Lifting Only	7
Figure 2: Correct Lifting of Pneumatic Single Acting Actuator	7
Figure 3: Use of Eyebolt for the Scotch Yoke Housing Cover	7
Figure 4: Vent Valve Correct Position	7
Figure 5: Correct Lifting Position for Actuator Models LDG-15, -20 and -25	7
Figure 6: Single Acting Actuator Center of Gravity Position	8
Figure 7: Double Acting Actuator Centre of Gravity Position and Lifting Arrangement (sizes LDG 15-20-25)	8
Figure 8: Double Acting Actuator Center of Gravity Position and Lifting Arrangement (sizes LDG 30 and larger)	8
Figure 9: Actuator's Safe Packed Position on Wooden Pallet	9
Figure 10: Fail CW Plate, According to EN 15714-3 Standard	10
Figure 11: Nameplate Sample	10
Figure 12: Standard Nameplate Position	10
Figure 13: Grounding Kit Detail	12
Figure 14: Grounding Kit Assembled	12
Figure 15: Grounding Kit – Exploded View	13
Figure 16: Single Acting Actuator Configuration: Fail Close – Fail Clockwise	14
Figure 17: Single Acting Actuator Configuration: Fail Open – Fail Counter Clockwise	14
Figure 18: Double Acting Actuator Configuration – Close Position	14
Figure 19: Double Acting Actuator Configuration – Open Position	14
Figure 20: Single Acting LDG in Fail Close Configuration With Valve	14
Figure 21: Double Acting LDG With Valve	14
Figure 22: Single Acting Actuator	19
Figure 23: Spring Can Exploded View	20
Figure 24: Exploded View of Pneumatic Cylinder – split ring version	22
Figure 25: Exploded View of Pneumatic Cylinder – threaded piston version	22
Figure 26: Exploded View of Housing	23
Figure 27: Exploded View of Assembling Kit	23
Figure 28: LDG Model Selection Table	28
Figure 29: LDG Weight Selection Table	29
Figure 30: Mounting Interface Dimensions	30
Figure 31: Actuator Orientation/Installation	31

# Tables

Table 1: Spare Parts List for Standard ON/OFF Applications	24
Table 2: Tightening Torques for Screws Without Lubricant (Tie Rods Excluded)	28
Table 3: Tightening Torque Table for Standard Cylinder. Tie Rods Without Lubricant.	28

# 1 Standard Information

## Using Flowserve Valves, Actuators and Accessories Correctly

The following instructions are designed to assist in unpacking, installing and performing maintenance as required on Flowserve products. Product users and maintenance personnel should thoroughly review this bulletin prior to installing, operating or performing any maintenance.

In most cases Flowserve actuators and accessories are designed for specific applications with regard to medium, pressure and temperature. For this reason they should not be used in other applications without first contacting the manufacturer.

### 1.1 Terms Concerning Safety

The safety terms **DANGER**, **WARNING**, **CAUTION** and **NOTE** are used in these instructions to highlight particular dangers and/or to provide additional information on aspects that may not be readily apparent.

 **DANGER:** indicates that death, severe personal injury and/or substantial property damage will occur if proper precautions are not taken.

 **WARNING:** indicates that death, severe personal injury and/or substantial property damage can occur if proper precautions are not taken.

 **CAUTION:** indicates that minor personal injury and/or property damage can occur if proper precautions are not taken.

 **NOTE:** indicates and provides additional technical information, which may not be very obvious, even to qualified personnel.

Compliance with other, not particularly emphasized notes, with regard to transport, assembly, operation and maintenance and with regard to technical documentation (e.g., in the operating instruction, product documentation or on the product itself) is essential, in order to avoid faults, which in themselves might directly or indirectly cause severe personal injury or property damage.

## 1.2 General Usage

The LDG actuator is designed to be operated by high pressure pneumatic fluids, including nitrogen and sweet natural gas.

 **WARNING:** for operation with sour gas consult Flowserve.

LDG actuator standard ambient and operating temperature range is: -29°C to 100°C (-20°F to 212°F).

Low temperature -60°C (-76°F) and high temperature 160°C (320°F) ranges (polar, cold, arid and tropical temperature requirements in accordance with IEC 60721) are available with different materials of construction. In any case please refer to the temperature range field located in the actuator nameplate.

 **NOTE:** For PED certified applications the standard operating temperature range is -20°C to 100°C (-4°F to 212°F). For lower temperature applications the range can be extended to -40°C to +100°C (-40°F to 212°F) or -50°C to +100°C (-58°F to 212°F) with different materials of construction. In any case, please refer to the temperature range located in the actuator nameplate.

 **WARNING:** the allowable pressure range of the supply fluids, as stated on the actuator nameplate must be respected. It is very important to carry out the recommended standard maintenance on all safety components. In case of PED certified cylinders the design pressure of the cylinder is indicated on a specific and separate nameplate: it is necessary to verify that the supply line to the actuator does not exceed the design pressure stated on the cylinder nameplate.

 **NOTE:** The standard supply fluids are high pressure instrument air, nitrogen and sweet natural gas. Different types of fluids may be used only after Flowserve verification. In case of PED certified cylinders the type of fluid is indicated on the specific nameplate on the cylinder.

 **WARNING:** Only use the recommended type of fluid that is indicated on the nameplate (PED cylinders) and/or in the contract.

## 1.3 Protective Clothing

Flowserve products are often used in problematic applications (e.g., extremely high pressures, dangerous, toxic or corrosive media). When performing service, inspection or repair operations, always ensure that the valve and actuator are depressurized and that the valve has been cleaned and is free from harmful substances. In such cases pay particular attention to personal protection (protective clothing, gloves, glasses, etc.).

## 1.4 Qualified Personnel

Qualified personnel are people who, on account of their training, experience, instruction and their knowledge of relevant standards, specifications, accident prevention regulations and operating conditions, have been authorized by those responsible for the safety of the plant to perform the necessary work and who can recognize and avoid possible dangers.

## 1.5 Other Requirements for In-plant Installation

- Pipelines must be correctly aligned to ensure that the valve is not fitted under tension.
- If not expressly agreed, fire protection is not supplied along with the actuator and it must be provided by the user.

 **Note:** the LDG actuator may be supplied with its specific Medium High Pressure Control group (MHPC) assembled on board. In these cases, refer to the appropriate instruction manual provided with the MHPC for additional instructions.

## 1.6 Spare Parts

Use only Flowserve original spare parts. Flowserve cannot accept responsibility for any damages that occur from using spare parts or fastening materials from other manufacturers. If Flowserve products (especially sealing materials) have been in storage for long periods, check these for corrosion or deterioration before using these products. A table with the list of the main spare parts for standard ON/OFF applications with the interval times can be found in Paragraph 4.5 at Table 1.

## 1.7 Service/Repair

To avoid possible injury to personnel or damage to products, safety terms must be strictly adhered to. Modifying this product, substituting non-factory parts, or using maintenance procedures other than as outlined in this instruction could drastically affect performance and be hazardous to personnel and equipment, and may void existing warranties.

Between actuator and valve there are moving parts. To avoid injury, Flowserve provides pinch-point-protection in the form of cover plates. These protections are according to Machine Directive 2006/42/EC recommendations. If these plates are removed for inspection, service or repair, special attention is required. After completing work the cover plates must be refitted.

In addition to the operating instructions and the obligatory accident prevention directives valid in the country of use, all recognized regulations for safety and good engineering practices must be followed.

 **WARNING:** Before products are returned to Flowserve for repair or service, Flowserve must be provided with a certificate which confirms that the product has been decontaminated and is clean. Flowserve will not accept deliveries if a certificate has not been provided (a form can be obtained from Flowserve).

## 1.8 Actuator Lifting and Handling

Only Allen wrenches and hexagonal wrenches of the few sizes are required for the overall operations. The lifting equipment consists of commercial chains and slings of adequate dimensions.

In order to prevent damage to actuator accessories, before starting the lifting operations, ensure that the lifting tools, like chain and clevis hook, are in the correct position and do not interfere with the control panel and related tubing.

 **WARNING:** the LDG actuator may be supplied with its specific Medium High Pressure Control group (MHPC) assembled on board. In these cases, refer to the appropriate instruction manual provided with the MHPC for additional instructions.

 **CAUTION:** Lifting and handling of the actuator should be done by qualified staff and in compliance with the laws and regulations in force.

 **WARNING:** The lifting lugs or eyebolts are appropriate for actuator lifting only. They are not designed to support the combined weight of the valve and actuator assembly together. During the lifting operations do not stand under the actuator. The actuator should be handled with appropriate lifting means. The weight of the actuator is reported on the packing slip and on the overall-dimensions drawing furnished with the documents accompanying the actuator.

For actuator weight, please, refer to Figure 29 in the Annex section. For the general actuator dimensions, please refer to LDG technical bulletin LFENTB0005, available on [www.flowserve.com](http://www.flowserve.com).

**WARNING:** Only for LDG models 30 and larger

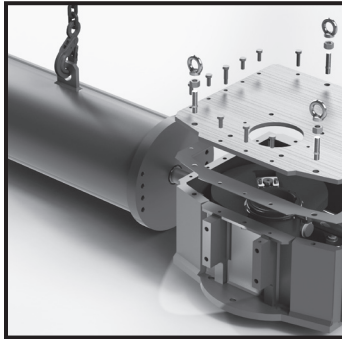

Figure 1: Lifting Lug for Spring Can Lifting Only



**DANGER:** For lifting and handling, use the eyebolts on the housing. The eyebolt on the spring can (for single acting version) is only for the mounting/dismounting steps or eventually for balancing the actuator.

Figure 2: Correct Lifting of Gas Powered Single Acting Actuator

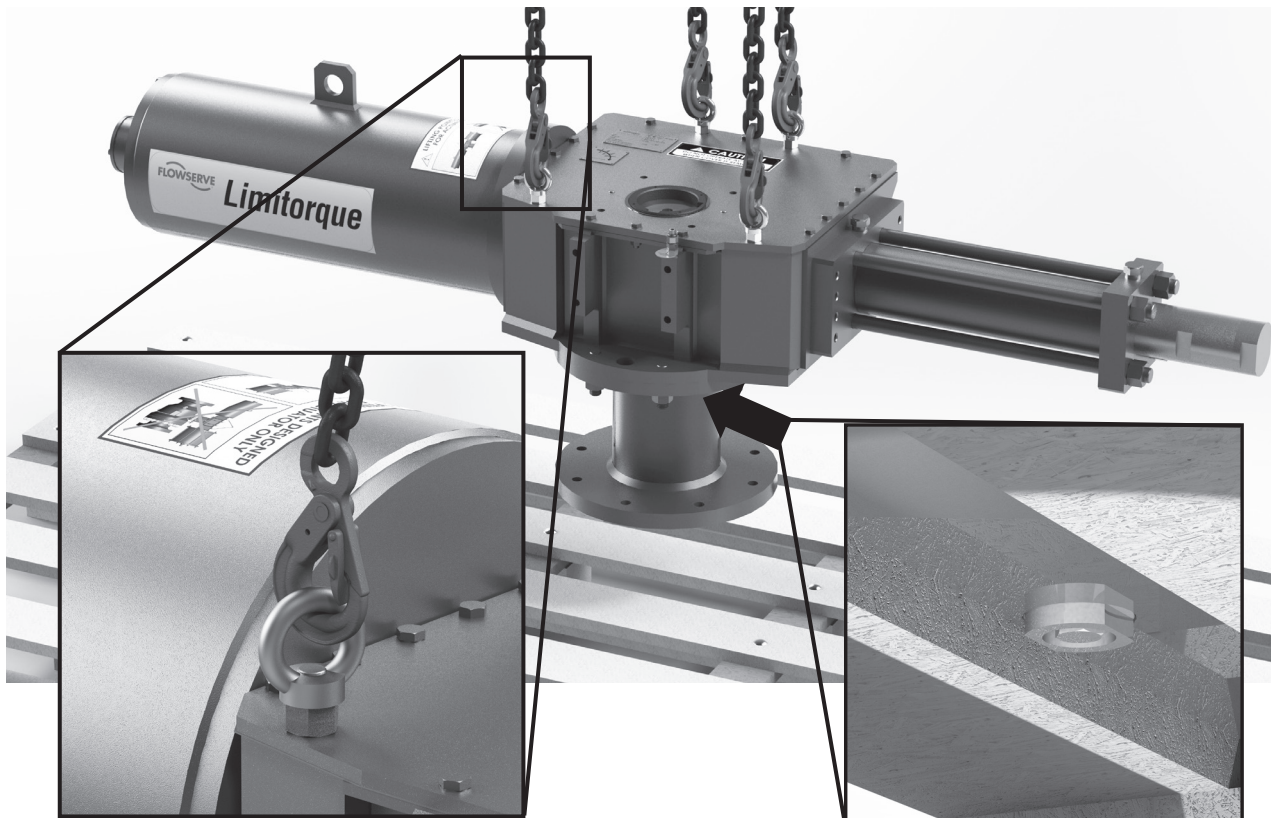

Figure 3: Use of Eyebolt for the Scotch Yoke Housing Cover

Figure 4: Vent Valve Correct Position

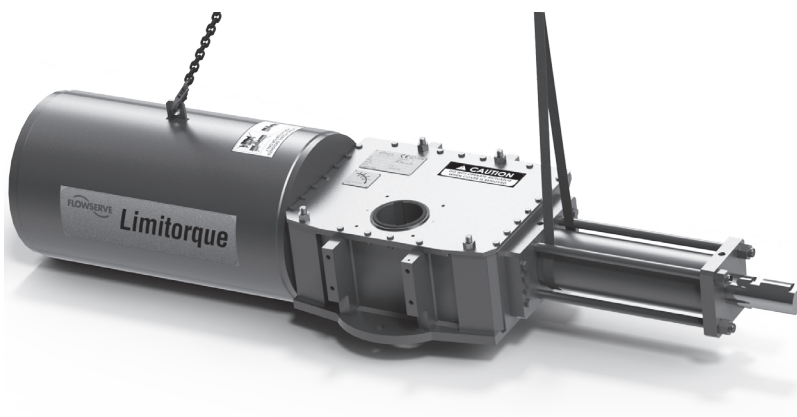

Figure 5: Correct Lifting Position for Actuator Models LDG -15, -20 and -25



**WARNING:** Only for LDG -15, -20 and -25 models.

**⚠ WARNING:** Only for actuator balancing or spring container mounting/dismounting operation.

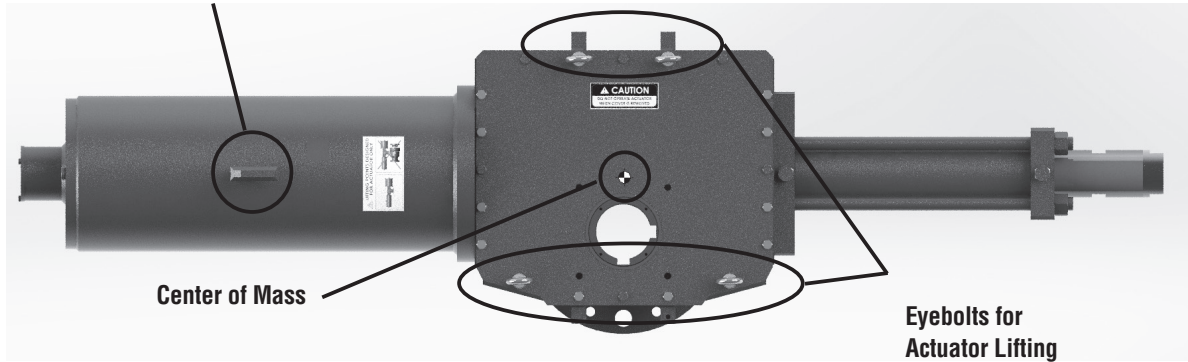

Figure 6: Single Acting Actuator Center of Gravity Position

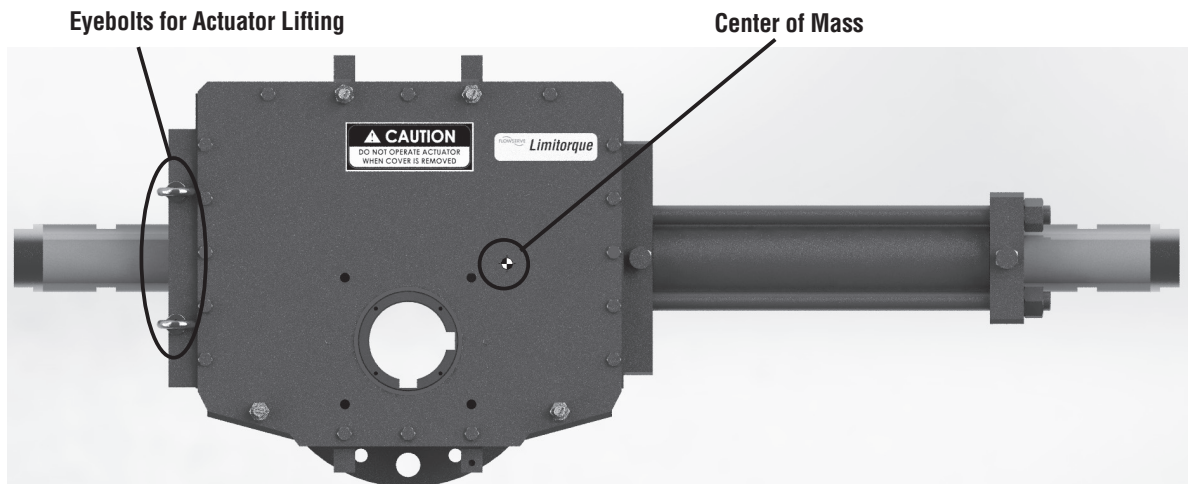

Figure 7: Double Acting Actuator Centre of Gravity Position and Lifting Arrangement (sizes LDG 15-20-25)

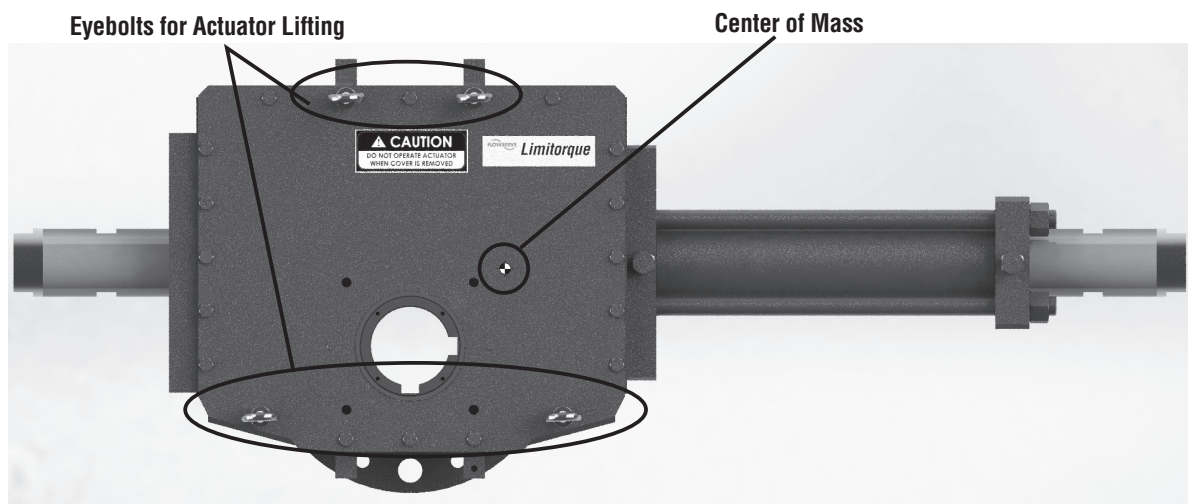

Figure 8 Double Acting Actuator Center of Gravity Position and Lifting Arrangement (sizes LDG 30 and larger)

**⚠ WARNING:** For lifting and handling use the appropriate lifting arrangement, as shown in Figures 2, 3 and 5. Do not lift the actuator with the valve assembled.

**⚠ WARNING:** After transportation, inspect the components to look for any possible damage.



## 1.9 Storage

Flowserve actuators are typically provided with an epoxy resin coating or with other painting systems as agreed with the customer. This means that Flowserve products are well protected from corrosion. Nevertheless, in order to maintain good working conditions and a good finish, until the actuator is installed in the plant, it is necessary to follow a few rules during the storage period:

- Flowserve actuators must be stored adequately in a clean, dry environment.
- Ensure that plastic caps are fitted to protect the pneumatic connections and the cable entries, to prevent the ingress of foreign materials. These caps should not be removed until the product is actually mounted into the system.
- If the storage is outdoors, or if long-term storage is necessary, the plastic protection plugs must be replaced with weatherproof metal plugs.
- The actuator must be placed on a wooden pallet, in order to not damage the coupling base and avoid the other surfaces resting on the ground.

In case of long-term storage, additionally perform the following measures:

- Coat the coupling parts (spool piece base, flanges, bushings, joints) with protective oil or grease.
- If possible, blank off the spool piece base flange with a protection disk.
- Provide a tarpaulin cover or some other means of protection, especially if the storage is outdoors.

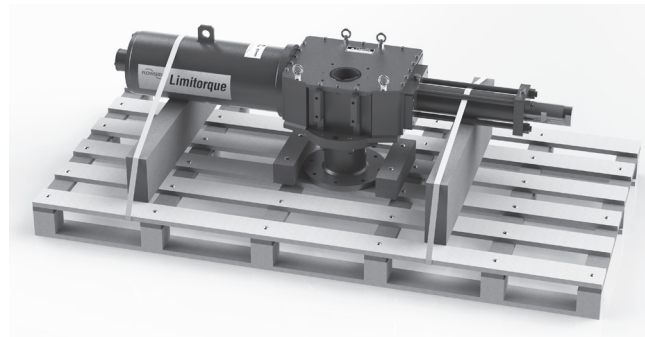

Figure 9: Actuator's Safe Packed Position on Wooden Pallet

## 1.10 Valve and Actuator Variations

These instructions cannot claim to cover all details of all possible product variations, nor can they provide information for every possible example of installation, operation or maintenance. This means that the instructions normally include only the directions to be followed by qualified personnel where the product is being used for its defined purpose. If there are any uncertainties in this respect, particularly in the event of missing product-related information, clarification must be obtained via the appropriate Flowserve sales office.

## 1.11 Unpacking

- Each delivery includes a packing slip. When unpacking, check all delivered actuators and accessories using this packing slip.
- Report transportation damage to the carrier immediately.
- In case of discrepancies, contact your nearest Flowserve location.
- If necessary, retouch minor damage to the paint coating which may have occurred during transport or storage.



**WARNING:** Ensure that the addendum “ATEX/PED/Machinery Directive Manual” accompanies this manual, when the actuator is under one (or more) of the following European Directives:

**2006/42/EC - MACHINERY DIRECTIVE**

**94/9/EC - ATEX DIRECTIVE**

**97/23/EC - PED DIRECTIVE**

**IF THE “ATEX/PED/MACHINERY DIRECTIVE MANUAL” IS NOT IN YOUR HANDS, CONTACT FLOWSERVE.**



**WARNING:** When the actuator has SIL requirements, ensure that the “LDG Series Safety Manual” (Functional Safety and SIL Certification) accompany this manual and is referred to for equipment usage.

# 2 Installation Instructions

The LDG Series is a fully modular design, Scotch yoke actuator, with mounting base dimensions in compliance with ISO 5211 (refer to Figure 30: Mounting Interface Dimensions in Annex Section for details of exacts coupling). It may also be customized, if required.

The LDG gas powered Scotch yoke spring return actuators adopt a push-to-compress spring design.

**! WARNING:** Actuator operation/pressure limitations must be in accordance with data reported on actuator nameplate.

Figure 10:  
Fail CW Plate, According to  
EN 15714-3 Standard



Figure 11:  
Nameplate Sample

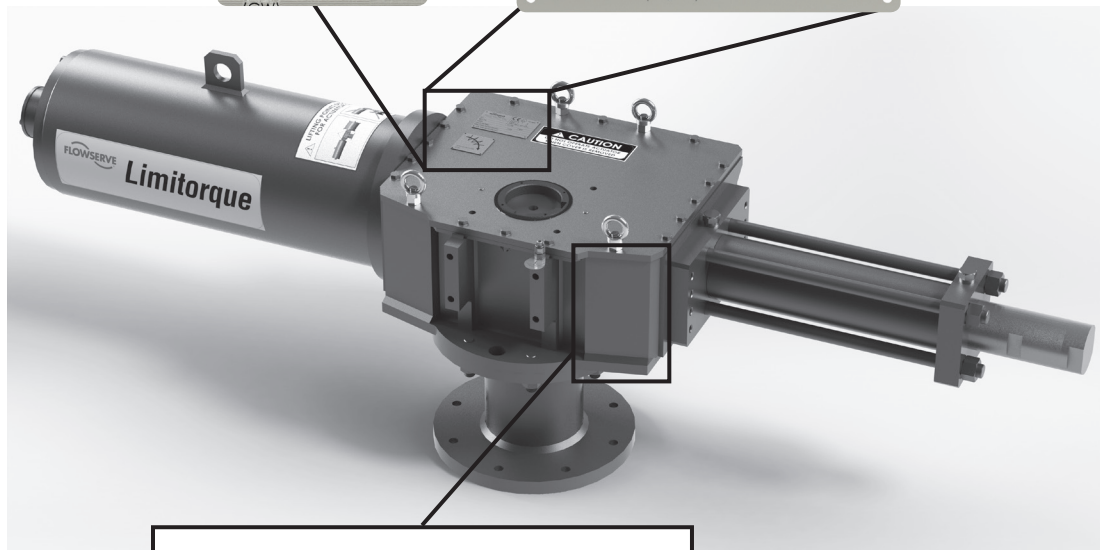
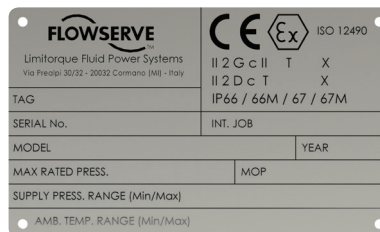

The Flowserve nameplate is normally situated on the cover of the Scotch yoke housing; if it's not possible, it could be situated in the front zone or in the rear zone of the Scotch yoke housing.

Figure 12: Standard Nameplate Position

**! NOTE:** The sense of rotation is defined by a dedicated plate, shown in Figure 10, in accordance with the EN 15714-3.

## 2.1 Valve and Actuator Check



**DANGER:** Before installation check the order-no., serial-no. and/or the tag-no. to ensure that the valve/ actuator is correct for the intended application.

Before mounting the actuator to the valve, manually open and close valve (if possible), to ensure it is not stuck. Be sure valve and actuator rotate in the same direction and are in the same position (i.e., valve closed, actuator closed). The assembly position of the actuator, with reference to the valve, has to be in accordance with the plant requirements.

## 2.2 Connection With Valve and Mounting Kit

The LDG actuator may be supplied with the spool piece already assembled. To assemble the actuator onto the valve, perform the following steps:

- 2.2.1 Check the mounting surfaces, the stem adaptor and the spool piece to assure proper fit. Clean the flanges of the valve and spool piece to remove oils and greases since the torque is transmitted by friction. Also, remove any rust that may have occurred during storage.
- 2.2.2 Secure the valve in the closed/open fail safe position, if possible with the stem vertical. Lubricate the valve stem in order to ease the assembly. Place the stem adaptor on the valve stem.
- 2.2.3 Lift the actuator by the special lift points (eyebolts), using a proper lifting system. Position the actuator over the valve and lower to engage the stem adaptor to the actuator bore. Continue to lower until the spool piece sits on valve mounting surface. This coupling has to take place without force and only with the weight of the actuator. The mounting bolts (or studs) of the valve should easily fit into the bolt holes of the spool piece without any binding. If needed, turn or stroke the actuator a few degrees and/or adjust the actuator travel-stops.
- 2.2.4 The mounting nuts (or bolts) connecting the base of the spool piece to the valve flange must be evenly tightened according to tightening torque table without lubricant (Table 2 in Annex section).

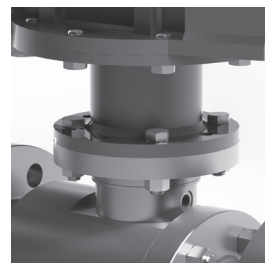
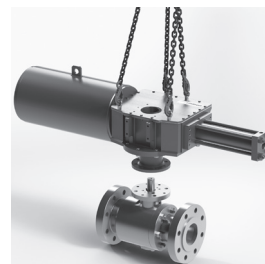
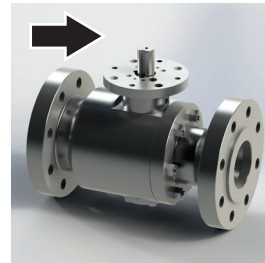
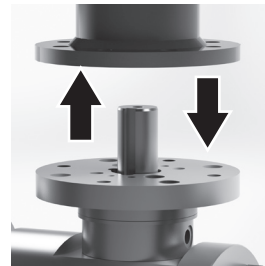

Alternatively, the coupling between valve and actuator can be direct, without the need of a spool piece. In these cases, Flowserve can provide an intermediate adaptor flange (fitted under the actuator base) and a special bushing to be inserted into the yoke bore.

- ⚠ **WARNING:** In case of spool piece (or adaptor flange) installation by the client, it is mandatory to refer to Figure 30, “Mounting Interface Dimensions” in Annex section, or to follow more specific instructions included in the job documentation supplied along with the actuator. These assembling instructions include details of prescribed stud bolts and their maximum allowable threaded length, in addition to the Loctite type to be used for perfect sealing of the Scotch yoke housing.
- ⚠ **CAUTION:** The actuator lifting and handling should be carried out by qualified staff and in compliance with the laws and provisions in force.
- ⚠ **WARNING:** The lifting lugs or eyebolts are appropriate for actuator lifting only. They are not designed to support the combined weight of the valve and actuator assembly together. During the lifting operations do not stand under the actuator. The actuator should be handled with appropriate lifting means. The weight of the actuator is reported on the packing slip and on the overall-dimensions drawing furnished with the documents accompanying the actuator.

## 2.3 Travel-stop Bolts and Accessories

All actuated valves require accurate travel-stop adjustments at both ends of the stroke to obtain optimum performance and valve seat life. Adjust the travel-stop bolts of the actuator for the proper open and close valve positions, per valve manufacturer’s recommendations.

The LDG actuators have travel-stop adjustments in both the clockwise and counter-clockwise directions. The +/- 5-degree adjustment feature provides shaft rotation from 80 to 100 degrees overall.

The adjustment of the travel-stops is performed in accordance with the following steps. Refer to Figures 23, 24 and 25.

Pneumatic cylinder stop (25): Loosen the seal nut (if present) with a proper wrench. Screw or un-screw the stop (25), using a proper Allen key, while keeping the seal nut stationary. Tighten the seal nut.

Spring container stop (7): Remove the spring container end flange (11) after unscrewing the hex screws (10). Screw or unscrew the end stop (7) to the desired position, using a proper Allen key. Replace the end flange and tighten the hex screws.

Pneumatic stroke the actuator several times to assure proper operation. The stem adaptor should not bind during operation. If the actuator is equipped with a switch, positioner or other accessories, adjust them at this time.

## 2.4 Grounding System

For the actuator earthing, use the grounding kit, shown in Figures 13, 14 and 15:

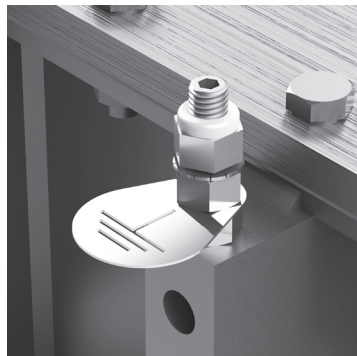

Figure 13: Grounding Kit Detail

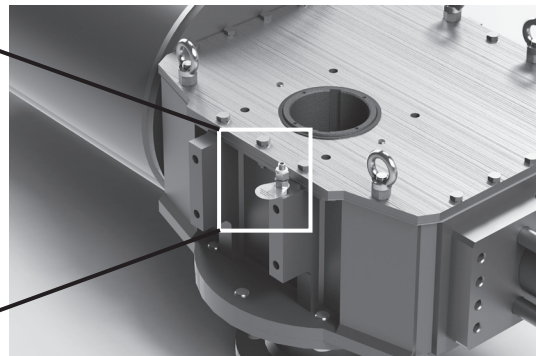

Figure 14: Grounding Kit Assembled

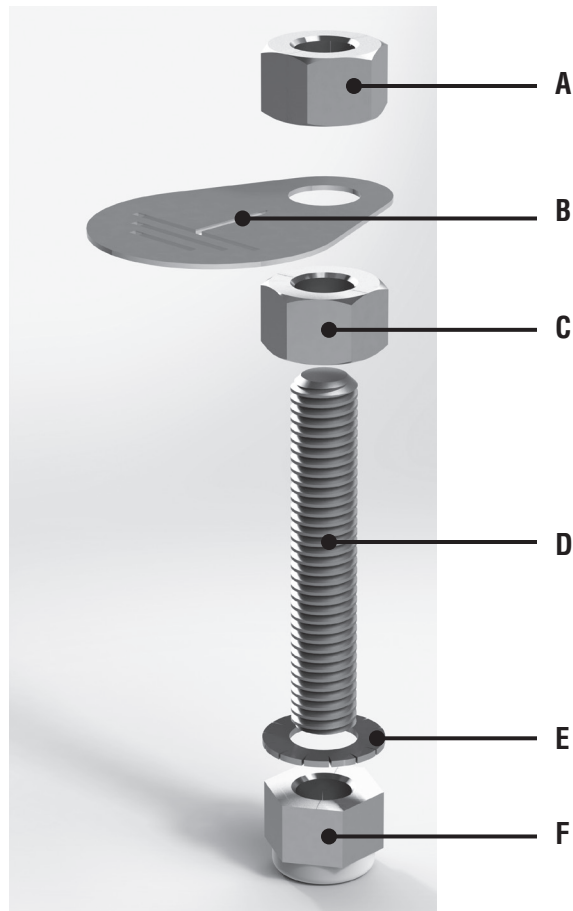

Figure 15: Grounding Kit – Exploded View

Letter	Description
A	High Nut
B	Ground Nameplate
C	High Nut
D	Grub Screw
E	Lock Washer
F	High Locking Nut With Nylon Insert

## 2.5 Initial Operation

Before initial operation of the actuator, perform the following checks:

- Check that all electrical supply, control and signal lines are properly connected, according to the appropriate plant or facility procedures.
- Check that the pressure and quality of the supply fluids are as prescribed.
- Check the absence of leaks in the pneumatic connections. If necessary, tighten the pipe fittings.
- Check that the environmental conditions are compatible with the design conditions. For information, contact Flowserve.

## 2.6 Fail Open and Fail Close Configuration

The actuator is designed to work in both configurations: fail open and fail close. For conversion from one configuration to the other, refer to next paragraph.

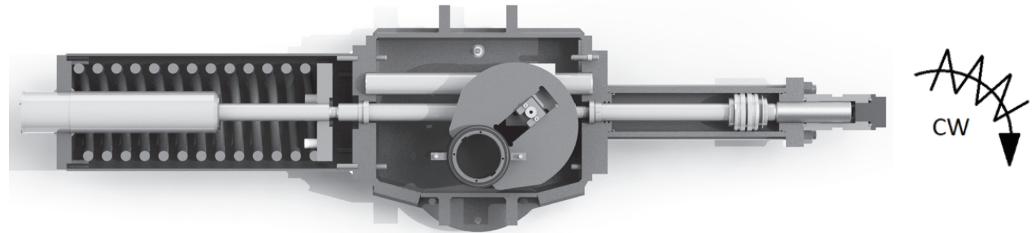

Figure 16: Single Acting Actuator Configuration: Fail Close – Fail Clockwise

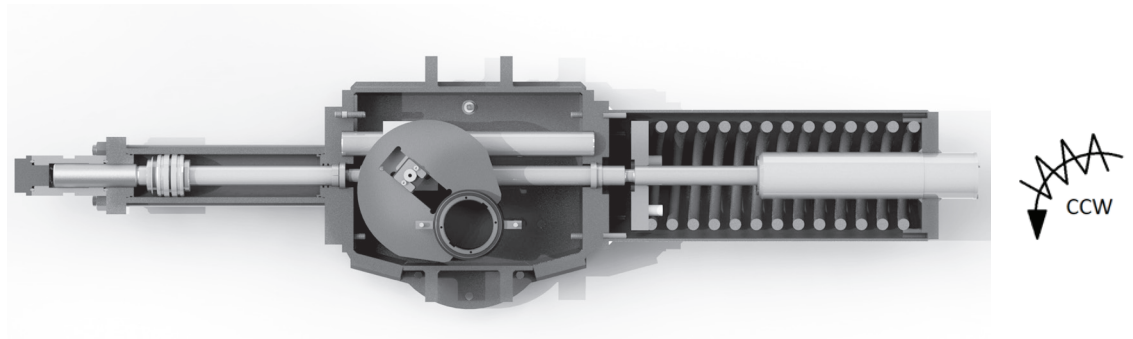

Figure 17: Single Acting Actuator Configuration: Fail Open – Fail Counter Clockwise

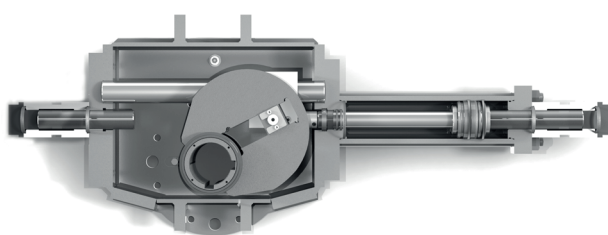

Figure 18: Double Acting Actuator Configuration – Close Position

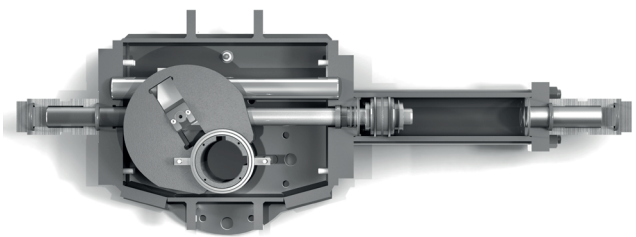

Figure 19: Double Acting Actuator Configuration – Open Position

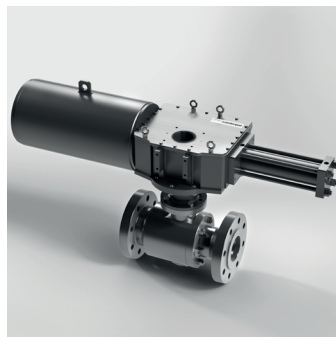

Figure 20: Single Acting LDG in Fail Close Configuration With Valve

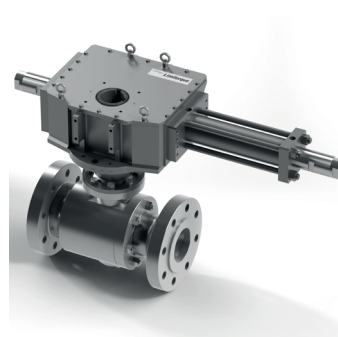

Figure 21: Double Acting LDG With Valve Close Configuration

# 3 Field Conversion

## Field Conversion From Fail CW to Fail CCW or Vice Versa (for Spring Return Actuators)

**! NOTE:**

- The actuator designation needs to be suitably changed on the nameplate.
- An additional adapter is required for field conversion from Fail CW to CCW and vice versa.

There are two different situations, requiring different sequences of instructions: in the first situation, the actuator is already disassembled from the valve. The second situation regards the conversion with the actuator assembled on the valve. The reference drawings are Figures 23 to 27.

### 3.1 Actuator Disassembled From the Valve



**WARNING:** Ensure that the pneumatic connection ports of the cylinder are disconnected. Also make sure that all pneumatic supplies to the control unit and all power supplies are disconnected. Finally, make sure that the actuator is in fail safe position, i.e., that it is not locked in a position with the spring compressed by means of locking devices.

3.1.1 Unscrew and remove the end stop (25) from the pneumatic cylinder. For removing the stop, refer to paragraph 2.3. If necessary, feed the pneumatic cylinder from the port on the head flange (19) at minimum necessary pressure to facilitate the movement of the Scotch yoke and assure the total retraction of the piston rod (20). Remove the pressure. In this way the spring is fully extended.

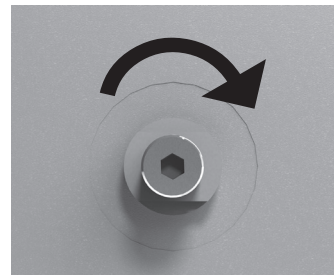

3.1.2 Remove the cover (46) from the housing by unscrewing all of the locking components: hex screws (45), hex head shoulder bolts (44) and eyebolts (42) plus upper nuts (43). Leave the studs (41) screwed into the housing (51).

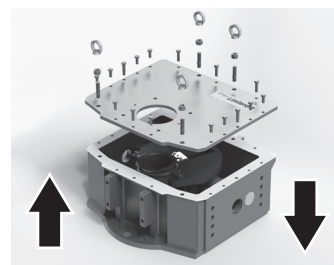

- 3.1.3 Remove the spring can, carefully following the instructions given in paragraph 4.2. Manually rotate the Scotch yoke (36) counterclockwise (or clockwise, depending on the original fail configuration) up to a position of approximately 45°. Locate the studs (57) that connect the housing to the pneumatic cylinder. With the Scotch yoke rotated of 45°, it is possible to easily access these studs. Carefully unscrew the nuts (56) and the studs (57). Pull out the whole pneumatic cylinder (the stem is fully retracted).

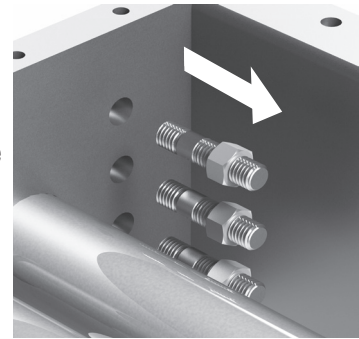

⚠ **NOTE:** Take care during removal, so as not to damage the piston rod or the stud threads.

- 3.1.4 Change the adapters. Replace the adapters (54 and 55) designed for fail close (open) action, with the new ones designed for the opposite action.

⚠ **NOTE:** Take care to choose the adapter kit suitable for the Scotch yoke type in use (symmetric or canted). Refer to point 3.2.7.

Reassemble the pneumatic cylinder with adapter, using the reverse procedure as described in paragraph 4.3.

⚠ **NOTE:** You can identify the cylinder adapter to the spring can adapter through the three grub screws (53).

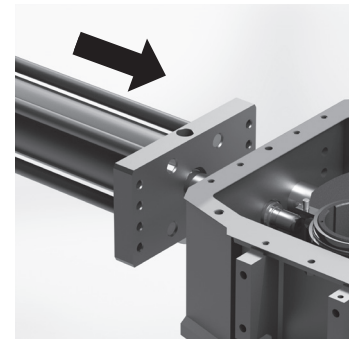

- 3.1.5 Manually rotate the Scotch yoke (36) until the guide block (48) is in contact with the piston rod adapter (54), in correspondence of the relevant slot.

Reassemble the spring can, as instructed in paragraph 4.2. Reposition the cover, taking care to replace the cover gasket (47). Readjust the stops, as instructed in paragraph 2.3. Repeatedly operate the actuator to check the functioning in the new fail configuration.

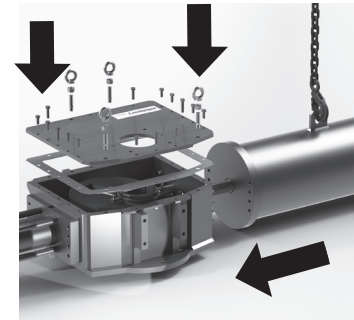

## 3.2 Actuator Connected to the Valve (and the valve can be stroked)

⚠ **NOTE:** If the valve cannot be rotated, due to the requirements of the plant, the actuator must be removed from the valve following the instructions given in paragraph 2.2. In this case, use the procedure described in paragraph 3.1. The actuator should be reinstalled in the same position of the valve.

⚠ **WARNING:** Make sure that all pneumatic supplies to the control unit and all power supplies are disconnected and if necessary, remove the control panel and accessories from the actuator. Finally, make sure that the actuator is in fail position, i.e., that it is not locked in a position with the spring compressed by means of locking devices.

- 3.2.1 Connect the pneumatic supply directly to the cylinder pneumatic port on the end flange and apply the minimum necessary pressure to move the actuator to approximately 45°. If the actuator is provided with a manual override, you can use it to perform this operation.

- 3.2.2 Measure the position of the spring can end stop (7), remove it, and then lock the spring in the compressed position by means of a special tool (provided by Flowserve upon request) for this maintenance. The tool is to be installed in the opening of the spring can end flange (11) where the spring-end travel-stop has been removed. Screw the special tool to the spring shaft and follow other detailed instructions provided with the special tool. Remove pressure from the hydraulic cylinder.





**WARNING:** At this point the spring is compressed and the spring module contains a large quantity of stored energy. Failure to properly engage the retaining device or failure to handle the spring carefully could result in release of the spring with potential damage to equipment or injury to personnel.

- 3.2.3 Unscrew and remove the travel-stop of the pneumatic cylinder (25). For removing the stop, refer to paragraph 2.3. Feed the pneumatic cylinder from the port on the head flange (19) at minimum necessary pressure up to totally retract the piston rod (20).
- 3.2.4 Remove the cover (46) from the Scotch yoke housing by unscrewing all of the locking components: hex screw (45), hex head shoulder bolts (44) and eyebolts (42) plus upper nuts (43). Leave the studs (41) screwed into the Scotch yoke housing (51).
- 3.2.5 Remove the spring can, carefully following the instructions given in paragraph 4.2.
- 3.2.6 Locate the studs (57) that connect the Scotch yoke housing to the cylinder. With the Scotch yoke (36) rotated 45°, it is possible to easily access these studs. Carefully unscrew the nuts (56). Pull out the whole pneumatic cylinder. The stem has to be fully retracted.



**NOTE:** Take care during removal, so as not to damage the piston rod or the stud threads.

- 3.2.7 Change the adapters. Replace the adapters (54 and 55) designed for fail close (open) action, with the new ones designed for the opposite action. Take care to choose the adapter kit suitable for the Scotch yoke type in use (symmetric or canted). The guide block (48) of the symmetric Scotch yoke is marked with the “S” letter on the top face, while the guide block of the canted Scotch yoke is marked with a “C” letter on the top face, as shown in the pictures at right.



**NOTE:** The spring can adaptor (55) and cylinder adaptor (54) can be inserted in the guide block in one way only, pending on the Fail Close (CW) or Fail Open (CCW) configuration. Component numbers are referred to in Figures 26 and 27.

- 3.2.8 Reassemble the spring can, as instructed in paragraph 4.2.
- 3.2.9 Reassemble the pneumatic cylinder with adapter, following the reverse procedure as described in point 4.3.
- 3.2.10 Apply the minimum pressure necessary to the pneumatic cylinder from the port on the end flange (27) until the piston rod moves the guide block (48) and partially compresses the spring. In this condition it will be possible to remove the special tool from the spring can.
- 3.2.11 Remove the pressure, checking that the actuator goes in the correct new fail safe position.
- 3.2.12 Reposition the cover, taking care to replace the cover gasket (47).
- 3.2.13 Readjust the travel-stops, as instructed in paragraph 2.3.

# 4 Maintenance Instructions

LDG Series actuators are designed to offer the greatest ease of operation during assembly, disassembly and maintenance. The maintenance and disassembly do not require special equipment or special or large wrenches. Furthermore, the joints among the moving parts of the actuator are made exclusively through pins and not using bolts that require tightening with specific torques.

LDG actuators do not need maintenance for long periods, even if they are working in severe conditions. The LDG actuator features a 25-year design life depending on service conditions, proper installation, operating and maintenance. In order to achieve this industry-leading design life, in-field maintenance is prescribed to be performed every six years of operations

However, if the actuator operation happens infrequently, it is recommended to periodically check the actuator, performing the following steps:

- In the plants where it is possible, carry out a few opening and closing operations, involving all the control unit components, checking that the actuator operates correctly and within the required stroking times.
- Check that all the signals (pneumatic and electric) arriving at the actuator are correct and that the supply fluid pressure is within the required range. Check for the absence of leaks in the pneumatic connections. If necessary, tighten the pipe fittings.
- Check the paint coating. If some areas are damaged due to accidental events, retouch them according to the paint specifications.

In case of scheduled preventive maintenance, or following accidental events, refer to the following maintenance instructions regarding the main actuator components (pneumatic cylinder and housing).

The actuator is furnished with lubricant sufficient for all its life cycle. In case of scheduled or extraordinary maintenance, it is possible to lubricate the parts of the housing with the following greases:

**For standard temperature conditions  
(-29°C/-20°F to +100°C/212°F)\***

<i>Oil Characteristics</i>	
Viscosity grade	220
Kinematic Viscosity at 40° [mm <sup>2</sup> /s]	222
Pour point [°C]	-39°

\* Oil suggested: Shell OMALA S4WE 220 or equivalent

**For low temperature conditions  
(down to -60°C/-76°F)\***

<i>Grease Characteristics</i>		
Worked Penetration	[dmm]	296
Dropping Point ASTM	[°C]	260
Base Oil Viscosity at -40°C		1150

\* Grease suggested: AEROSHELL 7 or equivalent

For different conditions, contact Flowserve.

## 4.1 General Disassembly Instructions

The LDG Series actuator is available in two different configurations, single acting and double acting, composed by the main parts shown in Figure 22: Single Acting Actuator.

- 4.1.1 Disconnect all pneumatic and electrical supplies from actuator.
- 4.1.2 If removal of the actuator from the valve is necessary, before dismounting the actuator remove all accessories from actuator. For removal of the Medium-High Pressure Control group MHPC where present, refer to the relevant instruction manual
- 4.1.3 The reference drawings for the instructions reported in the following paragraphs are the exploded views of single acting and double acting actuators, included as Figures 23 to 27.

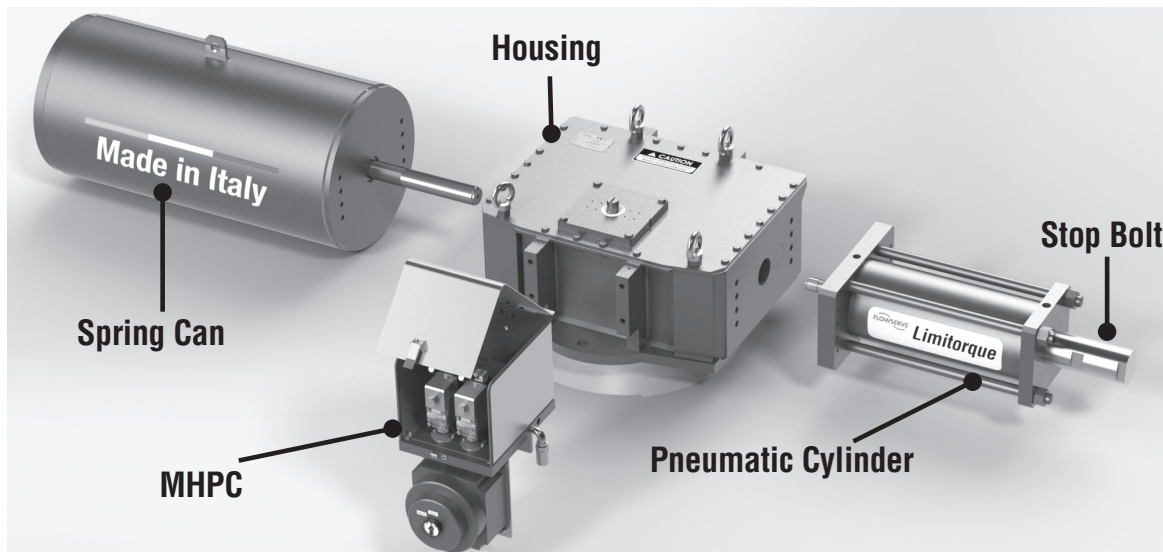

Figure 22: Single Acting Actuator

## 4.2 Spring Container Maintenance

The spring container does not require maintenance. The lubricating of internal parts is carried out during the assembly and is not necessary during the normal life of the actuator. The substitution of the spring container is not expected over the entire actuator life. However, accidental events may result in damage to this component. In these cases, proceed as described in the following steps.

The spring container is a single welded module. In case of damage, the whole container must be disassembled from the actuator and replaced with a new one equal to the original.

The removal of the spring container from the actuator has to be performed through the following steps. The reference drawing is Figure 23.

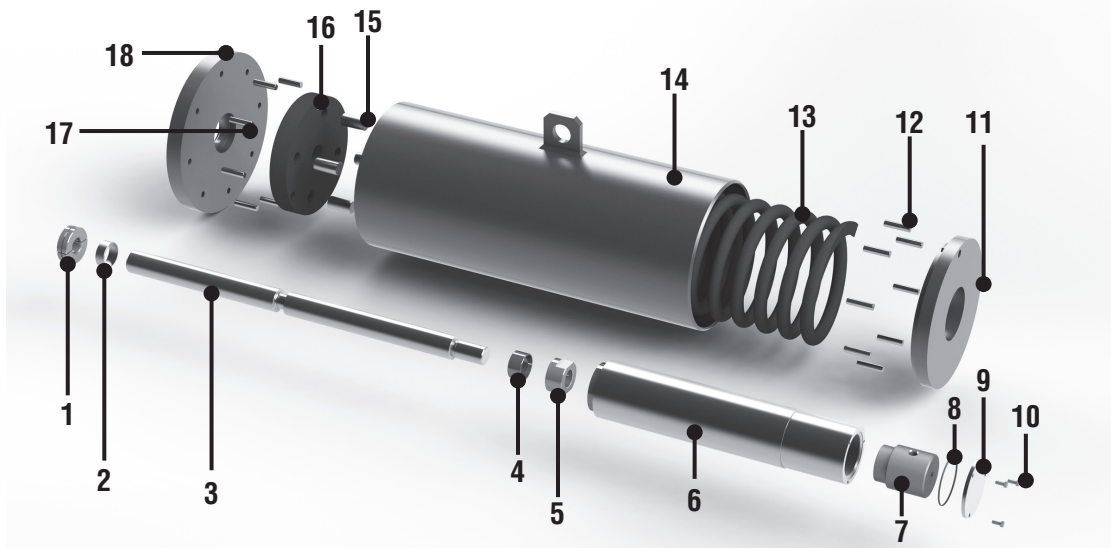

Figure 23: Spring Can Exploded View

Number	Description	Number	Description	Number	Description
1	Split Ring	7	Spring Stop Bolt	13	Spring
2	Bushing	8	O-Ring	14	Spring Can
3	Spring Rod	9	Stop Bolt Cap	15	Bar Pin
4	Bushing	10	Hex Screw	16	Spring Plate
5	Spring Rod End Nut	11	Spring Can End Flange	17	Bar Pin
6	Spring Guide	12	Bar Pin	18	Spring Can Head Flange

**WARNING:** Ensure that the pneumatic connection ports of the cylinder are disconnected. Also make sure that all pneumatic supplies to the control unit and all power supplies are disconnected. Finally, make sure that the actuator is in the fail safe position.

4.2.1 Unscrew and remove the travel-stop of the pneumatic cylinder (25). For removing the stop, refer to paragraph 2.3. If necessary, feed the pneumatic cylinder from the port on the head flange (27) at minimum necessary pressure to facilitate the movement of the Scotch yoke and assure the total retraction of the piston rod (20). Remove the pressure. This way the spring is fully extended.

4.2.2 Remove the cover (46) from the housing by unscrewing all of the locking components: hex screw (45), hex head shoulder bolts (44) and eyebolts (42) plus upper nuts (43). Leave the studs (41) screwed into the Scotch yoke housing (51).

4.2.3 Hook and hold in tension the spring container using the specific lifting lug located on the top of the spring can (shown in the picture). Care should be taken to choose a lifting system suitable for the weight of the spring container. Locate the studs (57) that connect the Scotch yoke housing with the spring container. Carefully un-screw the nuts (56) and the studs (57). Pull out the whole spring container.

**NOTE:** Take care to horizontally support the spring module during removal, so as not to damage the spring rod or the stud threads.

4.2.4 Before reassembling the new spring module to body, make sure stud threads are free of any dirt, shavings, or other debris. Clean threads with rag and solvent if required, and lubricate threads with an anti-seize compound. Assemble the new spring can, following the reverse procedure as described in points 4.2.3 to 4.2.5. Readjust the travel stop (25) of the pneumatic cylinder, as instructed in paragraph 2.3.

## 4.3 Pneumatic Cylinder Maintenance

The standard pneumatic cylinder maintenance mainly consists in the replacement of all parts that may degrade over time, even in the absence of faults. These components are the O-rings and the sliding elements of the piston.

The substitution of cylinder components (or of the whole cylinder) is not expected over the entire actuator life. However, accidental events may result in damage to these components. In these cases, proceed as described in the following steps.

There are two possible types of maintenance: standard maintenance which can be performed in the field without the need to remove the pneumatic cylinder from the actuator, and a more thorough one, following unexpected events, which often can be performed only after removing the cylinder from the actuator.



**DANGER:** Do not attempt this maintenance operation with cylinder under pressure.

### Standard In-field maintenance

The reference drawings are Figures 24/25.



**WARNING:** Before performing any maintenance operation on the cylinder it's mandatory to remove the pressure inside the cylinder. Ensure that the pneumatic connection ports of the cylinder are disconnected. Also make sure that all pneumatic supplies to the control unit and all power supplies are disconnected. Make sure that the actuator is in the fail position, i.e., that it is not locked in a position with the spring compressed by means of a special tool.



**WARNING:** Use the pneumatic cylinder only for its intended function.



**NOTE:** During the maintenance operation inside the cylinder, carry out a visual examination of the internal parts of the cylinder in order to guarantee their integrity.

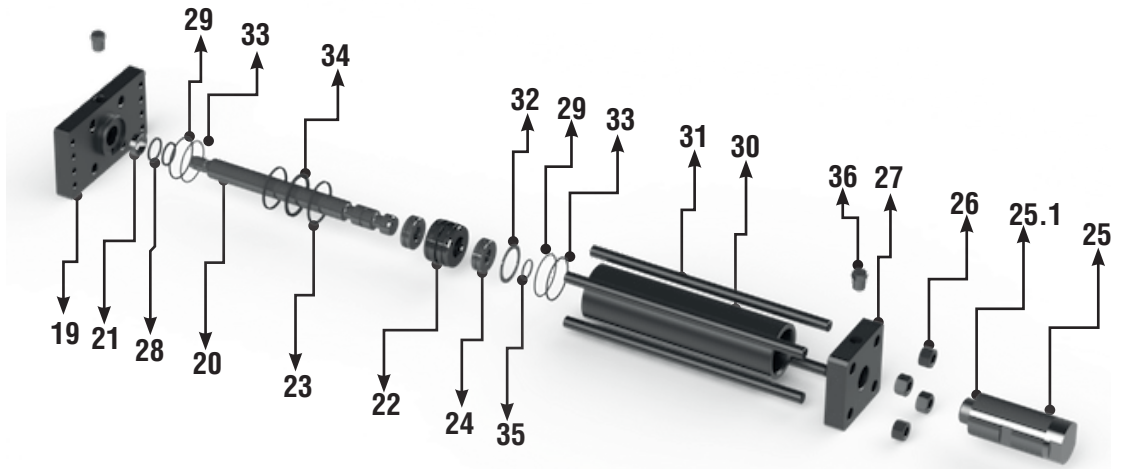

Figure 24: Exploded View of Pneumatic Cylinder – split ring version

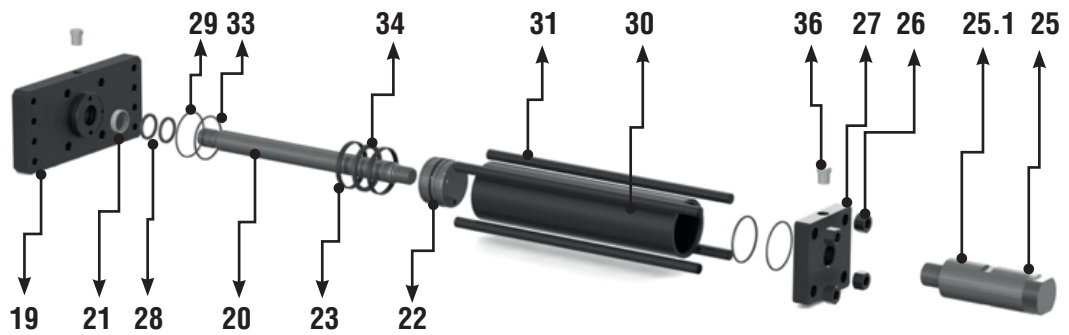

Figure 25: Exploded View of Pneumatic Cylinder – threaded piston version

Number	Description	Spare Parts*	Number	Description	Spare Parts*
19	Cylinder Head Flange		28	O-Ring (x2)	X
20	Piston Rod		29	Parback Ring (x2)	X
21	Bushing	X	30	Tube	
22	Piston		31	Tie Rod	
23	Guide Ring (x2)	X	32	Spiral Retaining Shaft Ring	
24	Split Ring		33	O-Ring	X
25	Stop Bolt Assembly		34	Seal	
25,1	Stop Bolt Protection		35	O-Ring	
26	Hex Nut (High)		36	Plugs	
27	Cylinder End Flange				

\* Standard maintenance spare parts for on/off applications

Perform the following steps:

- 4.3.1 If necessary, feed the pneumatic cylinder from the port on the head flange (19) at minimum necessary pressure to facilitate the movement of the Scotch yoke and assure the total retraction of the piston rod (20). In this way the spring is fully extended. Unscrew and remove the travel stop of the pneumatic cylinder. For removing the stop, refer to the indications given in paragraph 2.3.
- 4.3.2 Remove at least two of the tie rods (31) positioned on the upper part of the cylinder by unscrewing the nuts on the sides of the end flange and of the head flange (or unscrewing the tie rods from the head flange if threaded into the flange.) This operation provides two free holes to be used for lifting the end flange (27). Screw two male eyebolts in these two holes and connect the end flange to a lifting system. Care should be taken to choose a lifting system suitable for the weight of the cylinder. Refer to the weight table shown in Figure 29. Remove all other tie rods (31), following the same procedure described in point 4.3.2. Then carefully remove the end flange (27) from the tube (30).
- 4.3.3 Finally, remove the tube (30). Take care not to scratch or dent the honed and plated inner surface of the tube. Remove the O-rings (28) from the flange; remove the O-ring of the piston (33) and finally the guide tapes (23) from the piston. Clean all surfaces of piston and flanges in contact with these components with rag and solvent. Brush the O-ring grooves with a light oil film and install the new O-rings. Spread a thin layer of grease on the bottom of the guide tape grooves and install the new guide tapes (23). Clean the internal surface of the tube (30) and lubricate with a protective oil film.
- 4.3.4 Reassemble the parts of the cylinder with the reverse procedure as described from points 4.3.2 to 4.3.5. The tie rods should be tightened using a torque wrench, alternating between opposite holes, applying a torque according to Table 3 included in the Annex section. Readjust the stops as instructed in paragraph 2.3.

## 4.4 Scotch Yoke Housing Maintenance

Standard maintenance of the Scotch yoke housing may take place in the field, without the need to disassemble the spring container or the pneumatic cylinder. Perform the following steps. The reference drawings are Figures 27.

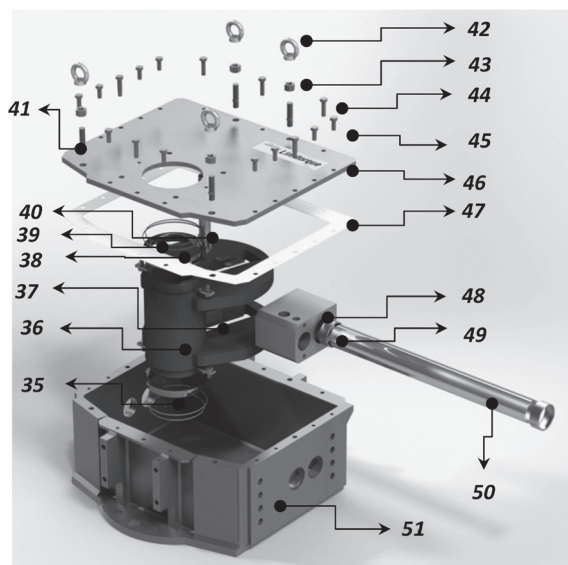

Figure 26: Exploded View of Housing

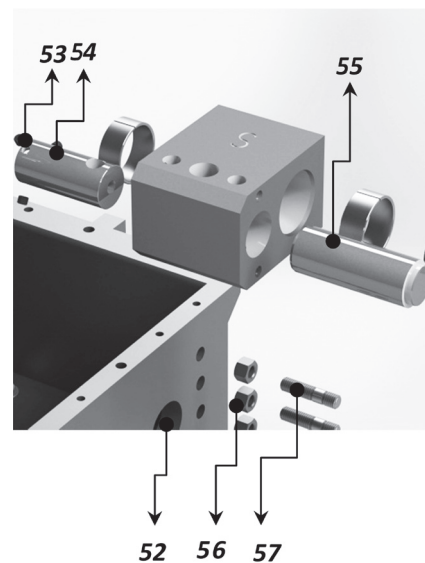

Figure 27: Exploded View of Assembling Kit

Number	Description	Spare Parts*	Number	Description	Spare Parts*
35	Bushing		44	Hex Head Shoulder Bolt	
36	Scotch Yoke		45	Hex Head Screw	
37	Slider Block (x2)		46	Cover	
38	O-Ring	X	47	Cover Gasket	X
39	O-Ring	X	48	Guide Block	
40	Guide Pin		49	Bushing	
41	Stud		50	Guide Bar	
42	Eyebolt		51	Housing	
43	Hex Nut (High)				

\* Standard maintenance spare parts for on/off applications

4.4.1 Remove the position indicators or other accessories, if fitted. Remove the cover (46) from the Scotch yoke housing by unscrewing all the locking components: hex screw (45), hex head shoulder bolts (44) and eyebolts (42) plus upper nuts (43). Leave the studs (41) screwed into the Scotch yoke housing (51). Remove the worn internal O-ring (39) of the bushing (35) inserted in the cover (46). Clean the O-ring groove and the sliding area of the bushing and after having brushed these surfaces with a light oil film, install the new internal O-ring (39).

4.4.2 Apply a generous layer of grease on the sliding surfaces of the accessible moving parts inside the housing. In particular, grease the guide bar (50) and the surfaces of the slots of the wings of the Scotch yoke (36), in which the slider blocks (37) run. Reposition the cover, taking care to replace the cover gasket (47).

Number	Description
52	Centering Ring
53	Grub Screw
54	Cylinder Adaptor
55	Spring Can Adaptor
56	Hex Nut (High)
57	Stud
58	Guide Adapter Pin <sup>1</sup>
59	Hex Head Screw <sup>1</sup>

<sup>1</sup> Only in double acting actuator

The design of LDG actuators features ease of on-site maintenance and an increased actuator life cycle. For this reason, appropriate procedures and equipment have been prepared, in order to allow the replacement of all parts of the Scotch yoke without the need to disassemble the actuator from the valve. For these operations, contact Flowserve.



**NOTE:** The spring can pneumatic cylinder and control group cylinder must be removed before disassembling the Scotch yoke housing.

## 4.5 Spare Parts

The main spare parts and the interval time for standard ON/OFF applications are listed in the table below. Part numbers are referred to in Figures 23 to 27.

Number	Description	Maintenance	Interval Times
21	O-Ring	6 years	1800 cycles
23	Tape Guide		
28	O-Ring		
29	Back-up Ring		
33	O-Ring		
38	O-Ring		
39	O-Ring		
47	Cover Gasket		

24 Table 1: Spare Parts List for Standard ON/OFF Applications



**WARNING:** It is recommended to follow the regular maintenance interval times indicated in Table 1.



# 5 Troubleshooting

To prevent the actuator from not properly functioning or low performance, first ensure that the installation and the adjustment operations are carried out completely in accordance with this manual.

 **WARNING:** When attempting to identify faults, it is very important to observe all the regulations and instructions about safety. Read all the paragraphs of this manual concerning maintenance before opening for inspection or starting to repair any actuator components. If in doubt, choose **SAFETY FIRST**.

The following table lists potential problems along with corresponding causes and possible solutions. If a malfunction cannot be identified and eliminated using the table, please contact a Flowserve representative.

Troubleshooting Table		
Problem	Possible Cause	Solution
The actuator does not move.	Actuator has not been properly installed.	Check that all the pneumatic connections and components have been installed correctly, and are in accordance with the actuator operating mode.
		Check that the actuator is properly connected to the valve and that there aren't problems in the mounting kit.
	Supply pressure problems.	Check that sufficient supply pressure is available at actuator inlet port. If possible, place a gage in line and monitor the pressure level, in order to discover unexpected pressure drops.
	Problems in the Medium-High Pressure Control (MHPC) group(if present).	Check the correct functioning of the control group. In particular, check all the hydraulic and electric connections.
		Check the correct level of supply voltage for solenoid valves and other electrical/electronic components.
	The valve is blocked.	Check that valve is free to rotate. If necessary, disassemble the actuator from the valve.
	Exhaust port(s) obstructed	Screw cap(s) must be disengaged. Ensure vent ports are free. If not, clean them of any obstructions and clean the dust excluders, if present.
Problems with lubricants.	Ensure that the actuator is properly lubricated, and that there is no solidified grease among sliding parts or rotating parts. If actuator lubrication is inadequate or improper, apply a uniform lubricant layer. Follow the instructions for center body and cylinder maintenance (par. 4.3). Consult Flowserve for proper oil and grease to be used.	

Troubleshooting Table		
Problem	Possible Cause	Solution
The actuator does not move.	A moving part is seized up.	Check if any moving part is blocked. If so, follow the maintenance instructions given in paragraphs 4.2, 4.3 and 4.4.
	Leakages of the pneumatic cylinder.	A significant gas leak may prevent the actuator from operating. Ensure that there aren't any leaks in the pneumatic cylinder toward the outside. Check also that there are not leaks across the piston. If leaks are present, follow the cylinder maintenance instructions given in paragraph 4.3.
	The actuator model is not the correct one, or is not suitable for the plant conditions.	Check the actuator nameplate and the plant requirements. If there are mismatches, contact Flowserve Service Department.
	Spring problems (if actuator is a single acting model).	Check the proper functioning of the spring can. If problems are found, contact the Flowserve Service Department.
		Perform the following test: disassemble the actuator from the valve and measure the minimum pressure values necessary to move and compress the spring. Compare the measured values with the ones reported on the Testing Certificate. If there are significant differences you should contact Flowserve Service Department.
A lockout device has been inserted and forgotten in that position.	Disconnect the lockout module.	
The valve does not shut off properly and there are leaks.	The actuator is not correctly adjusted.	Adjust the end stops of the pneumatic cylinder and of the spring can until the valve is leak-tight across the seat. Follow the instructions given in the paragraph about Travel-stop bolts (2.3).
The valve does not fully perform the stroke, during opening or closing.	The actuator is not correctly adjusted.	As above, check the position of the end stop in opening and closing direction. If necessary, adjust them. Follow the instructions given in paragraph 2.3.
	Actuator torque lower than required.	In order to do a check it is necessary to perform the following test: disassemble the actuator from the valve and measure the minimum pressure values necessary to move and compress the spring (if the actuator is a single acting model) or the minimum values necessary to move the actuator yoke and perform a stroke (for double acting models). Compare the measured values with the ones reported on the Testing Certificate. If there are significant differences you should contact Flowserve Service Department.
During the stroke the actuator exhibits excessive amounts of backlash.	Some components are excessively worn.	Identify and replace these components, according to the procedure described in paragraphs 4.2, 4.3 and 4.4.
In case of other problems not listed in this table, you should contact the Flowserve Service Department.		

# 6 Disposal of Decommissioned Actuators

 **WARNING:** Before disassembling the actuator from the valve and before any decommissioning activity ensure that the pneumatic connection ports of the cylinder are disconnected and open to the ambient. Also make sure that power and pneumatic supplies are turned off, and bleed any pressurized parts of the actuator, control panel and pneumatic tubing (including air tanks, if present). Verify that the actuator is in fail safe position, i.e., that it is not locked in a position with the spring compressed by means of locking devices.

Spring return actuators that are to be decommissioned permanently must have the stored energy in the spring neutralized. For Limitorque actuators, the spring module can be safely disassembled from the actuator if the supply pressure has been removed and the actuator is in its fail safe position: in fact, in this condition, any residual spring preload is not transmitted to the actuator. To disassemble the spring module from the actuator, follow the instructions provided at Paragraph 4.1 of this manual.

Once the spring module is disassembled from the actuator, the spring inside the spring module can be neutralized in different ways depending on the equipment available on-site. Please contact your Flowserve Limitorque representative to receive a dedicated procedure for spring module disposal, in order to safely perform this operation in the most appropriate way according to available equipment and tools.

 **WARNING:** Failure to neutralize the spring contained in the actuator's spring module or to follow these instructions could lead to injury to personnel or property damage.

No other specific actions need be taken on other portions/parts of the actuator for decommissioning. To disassemble the pneumatic cylinder and Scotch-yoke housing, follow the instructions provided respectively at Paragraphs 4.2 and 4.3 of this manual.

All disassembled parts of the actuator shall be separated according to their material type (metal, rubber, plastic, oil and grease, electric and electronic equipment ...). Dispose them with support of differentiated waste collection sites, as provided for by the laws and provisions in force.

# 7 Annex

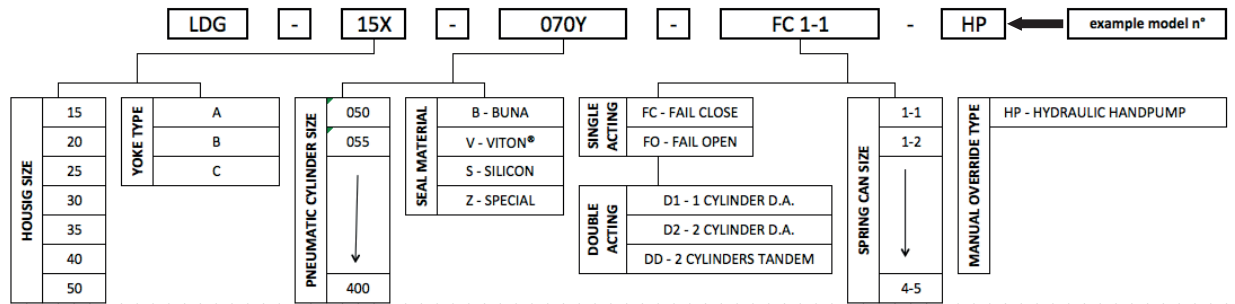

Figure 28: LDG Model Selection Table

Screw Diameter	Torque [Nm]
M3	1.1
M4	2.5
M5	5.0
M6	8.6
M8	21.0
M10	42.0
M12	72.0
M14	116.0
M16	180.0
M18	250.0
M20	354.0
M22	487.0
M24	609.0
M27	901
M30	1222
M33	1660
M36	2131
M39	2766
M42	3414
M45	4273
M48	5161
M52	6646
M56	8277
M60	10283
M64	12373

Tie Rods Diameter	Torque [Nm]
M16	135
M20	280
M24	465
M27	750
M30	1000
M33	1270
M36	1480

Table 3: Tightening Torque Table for Standard Cylinder. Tie Rods Without Lubricant.



LPS/LDG/LGO/LHS/LHH Series Coupling Dimensions													
Model	ISO 5211 Flange interface (reference)	ØA	B	C	Number of holes n	Hole Diameter ØD	P.C.D. [mm][inch]	F	ØG	ØH	I	L	P
LPS/LDG/LGO/LHS/LHH 15	F16	65	10	70.6	4	M20	165 (6.50)	18	86	78	161	8	155
LPS/LDG/LGO/LHS/LHH 20	F25	86	12	91.6	8	M16	254 (10)	16	1301	12	178	4.5	205
LPS/LDG/LGO/LHS/LHH 25	F30	1001	8	108.8	8	M20	298 (11.73)	18	150	133	201	6	230
LPS/LDG/LGO/LHS/LHH 30	F35	1302	8	138.6	8	M30	356 (14.02)	28	168	152	261	10	305
LPS/LDG/LGO/LHS/LHH 35	F40	150	36	166.8	8	M36	406 (15.98)	33	199	185	323	9	405
LPS/LDG/LGO/LHS/LHH 40	F48	185	45	205.8	12	M36	483 (19.02)	38	244	230	338	10	450
LPS/LDG/LGO/LHS/LHH 50	F60	230	50	252.8	20	M36	603 (23.74)	48	292	275	500	18	550

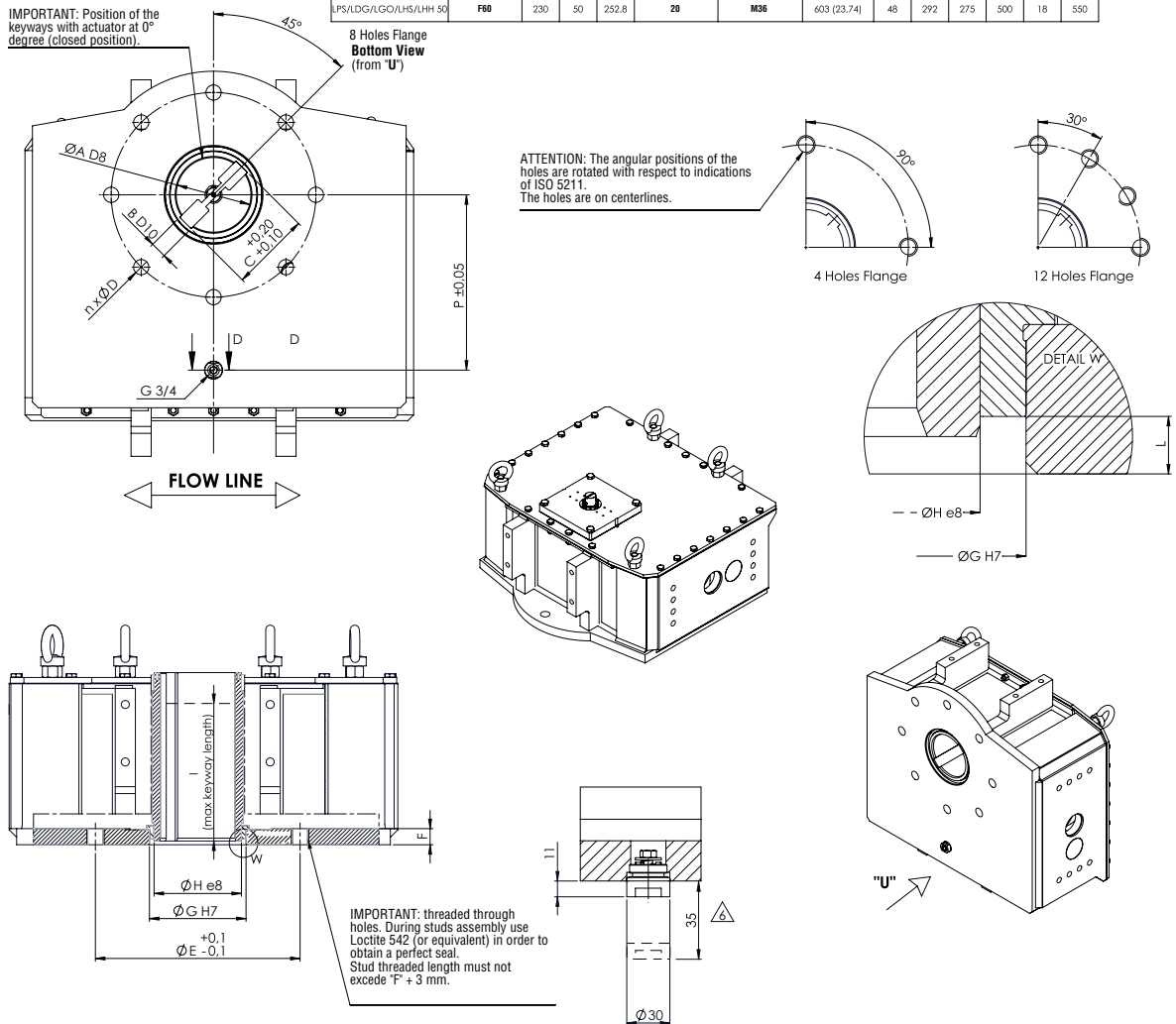

Actuator Size	ISO 5211 Flange Interface (Reference)	N. of Holes	P.C.D. [mm (Inch)]	Note
LDG-15	F16	4	165 (6.50)	• Holes in line with axis of actuator (NOT off-center)
LDG-20	F25	8	254 (10.00)	
LDG-25	F30	8	298 (11.73)	
LDG-30	F35	8	356 (14.02)	
LDG-35	F40	8	406 (15.98)	
LDG-40	F48	12	483 (19.02)	

Figure 30: Mounting Interface Dimensions

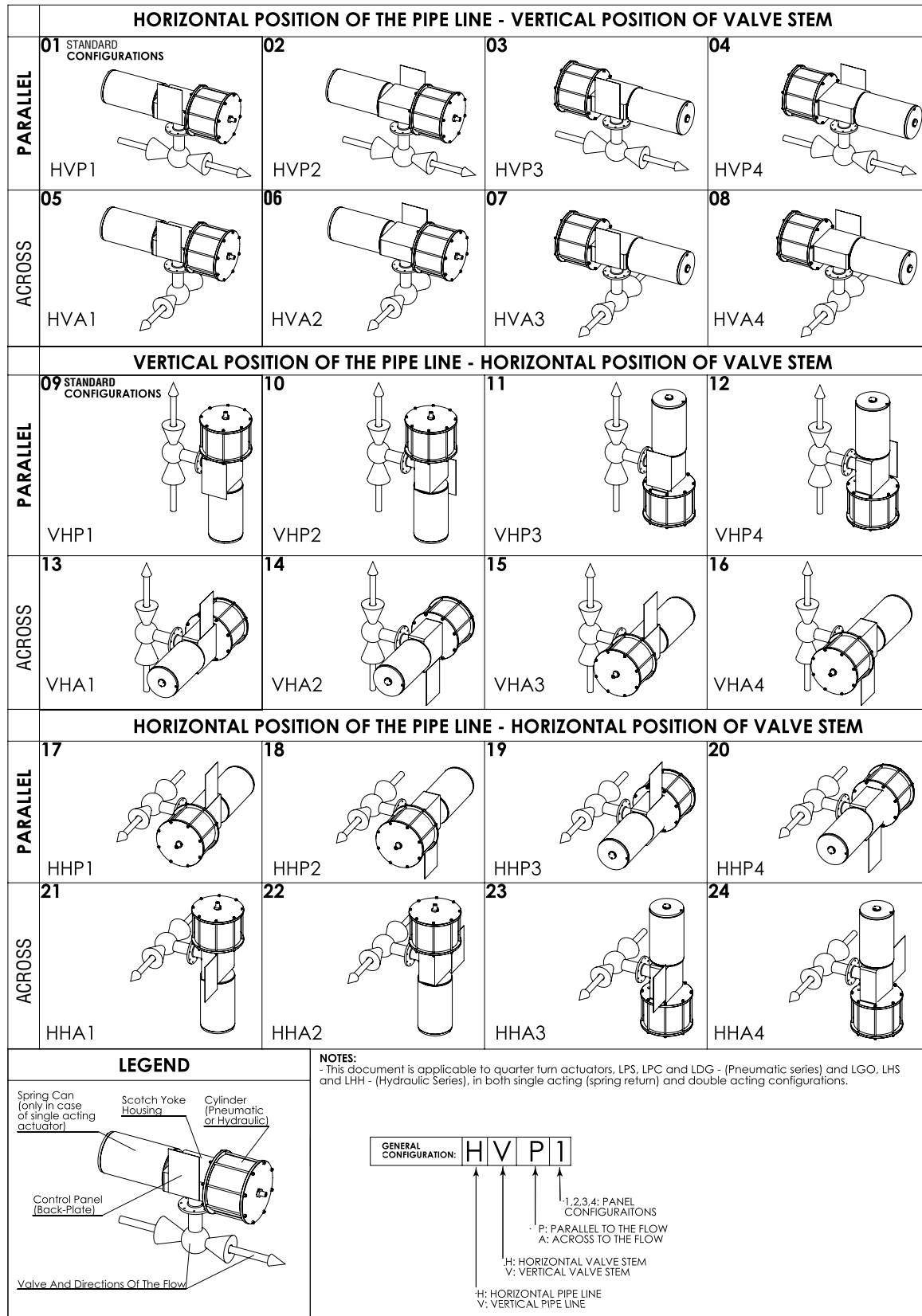

Figure 31: Actuator Orientation/Installation



**Flowserve Limitorque  
Fluid-Power Product Sales**

via Rio Vallone 17  
20883 Mezzago MB  
Italy  
Fax: +39 039 62060 213  
Phone: +39 620 601 200  
Email: [limitorque@flowserve.com](mailto:limitorque@flowserve.com)

**Flowserve Limitorque  
Fluid-Power Product  
Manufacturing and Operations**

via Rio Vallone 17  
20883 Mezzago MB  
Italy  
Fax: +39 039 62060 213  
Phone: +39 620 601 200  
Email: [limitorque@flowserve.com](mailto:limitorque@flowserve.com)

**Flowserve Limitorque  
Fluid-Power Product  
Research and Development**

Via Belizzi 40/42  
29122 Piacenza, PC  
Italy  
Email: [limitorque@flowserve.com](mailto:limitorque@flowserve.com)

**To find your local Flowserve representative,  
visit [www.flowserve.com](http://www.flowserve.com) or call:  
USA +1 800 225 6989  
International +1 972 910 0774**

FCD LFENIM0005-00 AQ 06/16 © 2016 Flowserve Corporation.

Flowserve Corporation has established industry leadership in the design and manufacture of its products. When properly selected, this Flowserve product is designed to perform its intended function safely during its useful life. However, the purchaser or user of Flowserve products should be aware that Flowserve products might be used in numerous applications under a wide variety of industrial service conditions. Although Flowserve can (and often does) provide general guidelines, it cannot provide specific data and warnings for all possible applications. The purchaser/user must therefore assume the ultimate responsibility for the proper sizing and selection, installation, operation, and maintenance of Flowserve products. The purchaser/user should read and understand the Installation Operation Maintenance (IOM) instructions included with the product, and train its employees and contractors in the safe use of Flowserve products in connection with the specific application.

While the information and specifications contained in this literature are believed to be accurate, they are supplied for informative purposes only and should not be considered certified or as a guarantee of satisfactory results by reliance thereon. Nothing contained herein is to be construed as a warranty or guarantee, express or implied, regarding any matter with respect to this product. Because Flowserve is continually improving and upgrading its product design, the specifications, dimensions and information contained herein are subject to change without notice. Should any question arise concerning these provisions, the purchaser/user should contact Flowserve Corporation at any one of its worldwide operations or offices.

© 2016 Flowserve Corporation, Irving, Texas, USA. Flowserve is a registered trademark of Flowserve Corporation.