



# Edward<sup>®</sup> Equiwedge<sup>™</sup> Forged Gate Valve



*Experience In Motion*

# Superior sealing performance. Improved process integrity and productivity.

The higher operating pressures and temperatures of today's supercritical and ultra-supercritical coal and combined cycle power plants place greater demands on flow control equipment. The Edward Equiwedge gate valve from Flowserve is engineered to handle the difficult operating conditions found in these and other critical service applications.

The Edward Equiwedge forged gate valve is the culmination of 100 years of experience engineering flow control equipment for power generation and other infrastructure industries. It delivers superior sealing performance and reliability, improving process integrity and plant efficiency.

## Hybrid design provides superior sealing performance

The key to the Equiwedge valve's exceptional sealing ability is its hybrid design. Incorporating the best design elements of a parallel slide gate valve and a flexible wedge gate valve, the Equiwedge valve effectively minimizes leakage across the seats. It reduces steam loss, which can affect productivity and profit.

The design utilizes two independent wedges (gates) that provide the required flex to accommodate for distortion loads. This feature also reduces thermal binding, wear and stress on valve components, greatly increasing equipment longevity and reducing maintenance costs.

## Forged reliability with optimized weight

Machined from a single piece of forged material without any fabrication welds, the Edward Equiwedge gate valve is extremely robust and reliable. The risk of body failure due to poor welding practices is greatly reduced and safety is greatly improved.

The valve's construction marries the design criteria and allowable stress levels of EN 12516-2 with the ASME B16.34 design standard to selectively increase valve wall thicknesses in critical areas. The outcome is a valve design that provides strength where it is needed most, while optimizing weight. Weight reduction is important, as it lowers the level — and therefore cost — of pipe supports.

As a result, the Equiwedge gate valve is an effective solution for applications in which maximum performance, reliability and safety are required and valve weight is a concern.

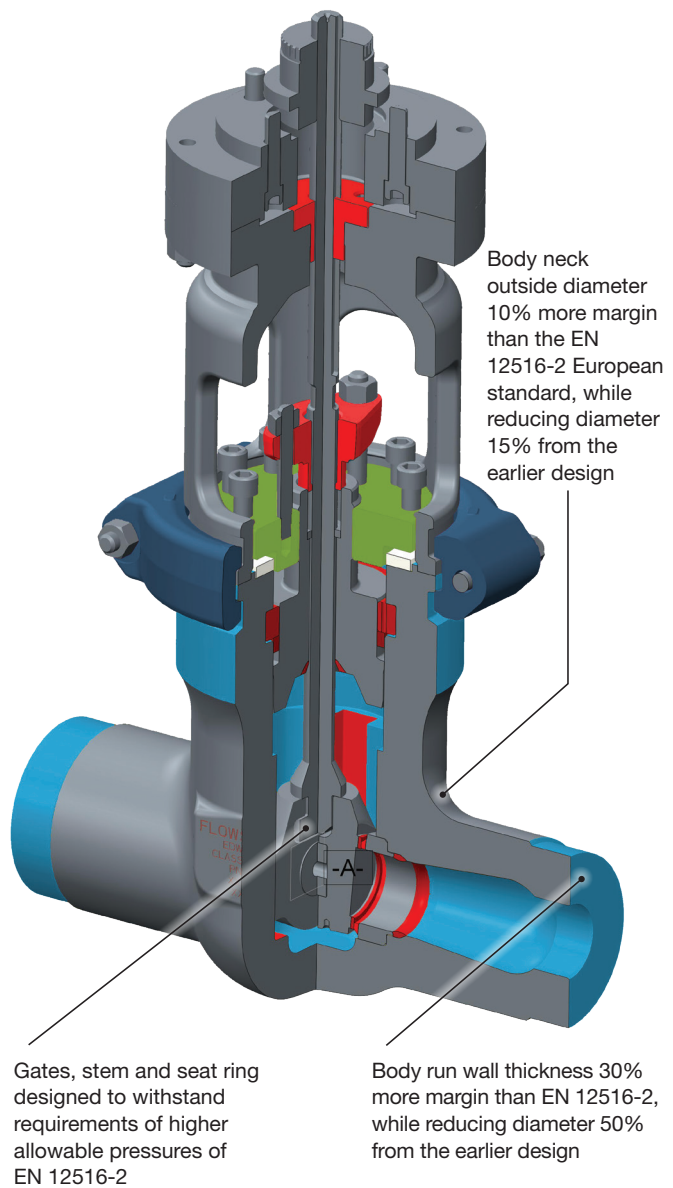

## Typical applications

The Equiwedge gate valve is well-suited for numerous applications in supercritical and ultra-supercritical power plants. (See table and diagram below.) Other Flowserve Edward, Valtek® and McCANNA™ brand valves round out the critical valve applications found in those plants.

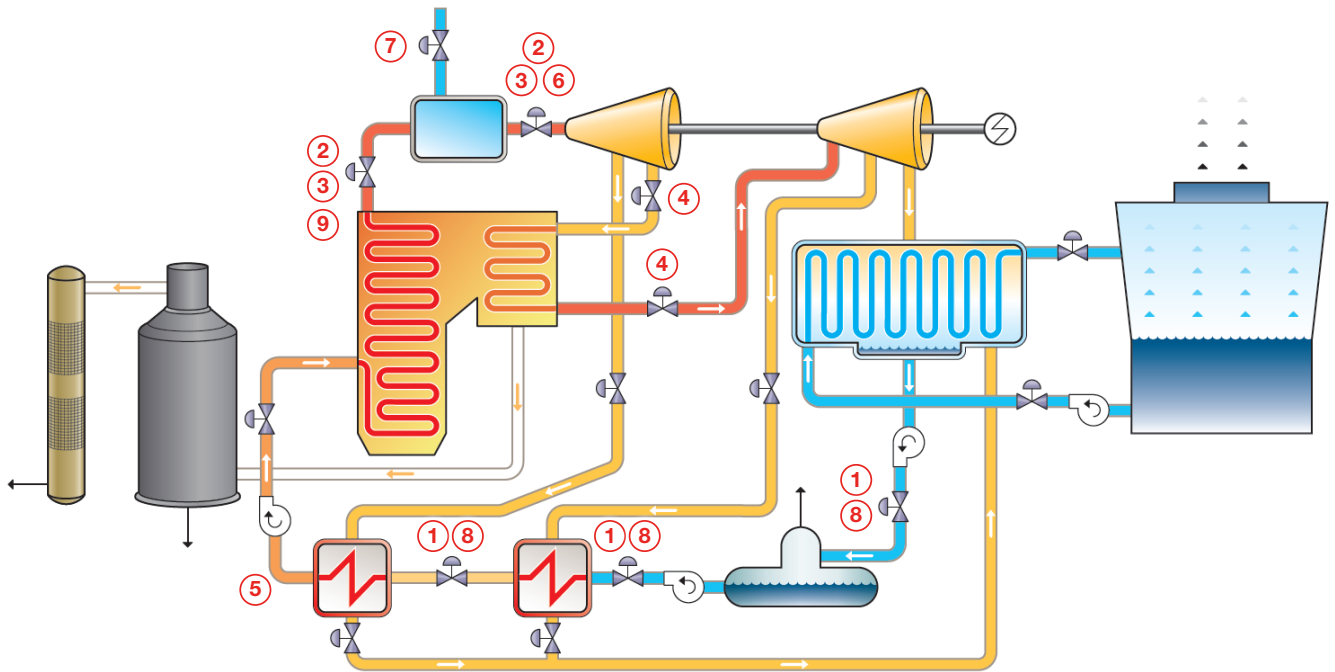

Pos.	Application	Recommended Products
1	Feedwater stop and check valves	Edward Equiwedge, Edward Flite-Flow®
2	Main steam stop valve	Edward Equiwedge
3	Main steam check valve	Edward Flite-Flow
4	Reheat stop valve	Edward Equiwedge
5	Economizer stop valve	Edward Equiwedge
6	Startup/steam bypass valve	Edward Equiwedge
7	Boiler, turbine, steam line drain valve	Edward Univalve®
8	Control valves	Valtek Series
9	Emergency shutdown valves	McCANNA

# Sealing assurance ... even at low differential pressures

The Edward Equiwedge gate valve uses a two-piece flexible wedge sealing system. Wedging action provides tight seat sealing without sticking, even at low differential pressures.

Wedge guide area and strength enable the capability to support high differential pressures with the valve partially open, so Equiwedge gate valves can be opened or closed under “blowdown” conditions. Bypasses are not required if full differential is specified for actuator sizing.

## Two-piece wedge

The two-piece wedge design of the Equiwedge gate valve permits maximum independence and flexibility for good scalability and freedom from sticking.

Wedge and body seat wear is minimized, since the seating surfaces are in contact less than 5% of the total travel. The wedge halves are free to align with the seats, even when they are tilted or rotated due to thermal effects or piping loads. Resistance to thermal binding assures opening with a torque or load less than design closing load.

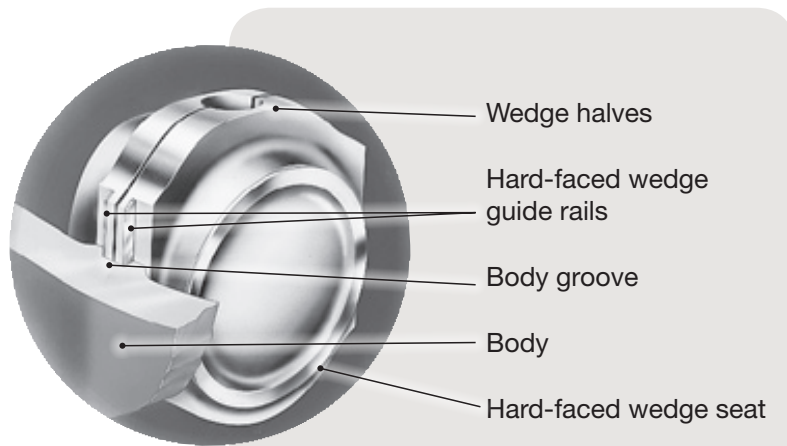

## Guiding system

The two flexible wedge halves are guided by grooves in the body. The body grooves extend high in the body neck region, so the wedge assembly is both trapped and fully guided when in the open position.

Body grooves are hard-faced for critical service valves.

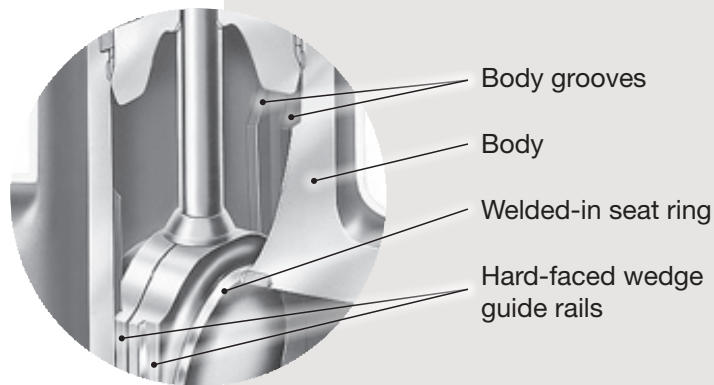

## Captured stem

The two-piece wedge design of the Equiwedge gate valve enables the use of a simple but reliable captured stem connection. The integral stem head pocket is the strongest gate/stem interface. It provides flexibility while ensuring a robust connection. Lighter and more compact than bolt-on flanges and not subject to binding stresses often associated with threaded connections, the captured stem is easier to actuate and maintain.

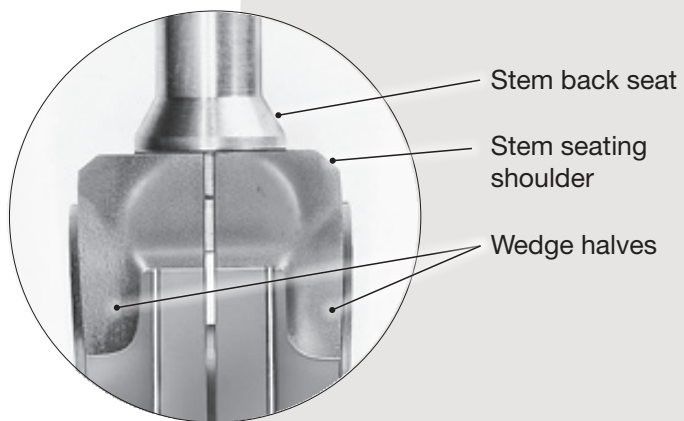

## Spacer ring

In the closed position, the wedge halves are separated the proper amount by a spacer ring that provides controlled deflection from stem loading.

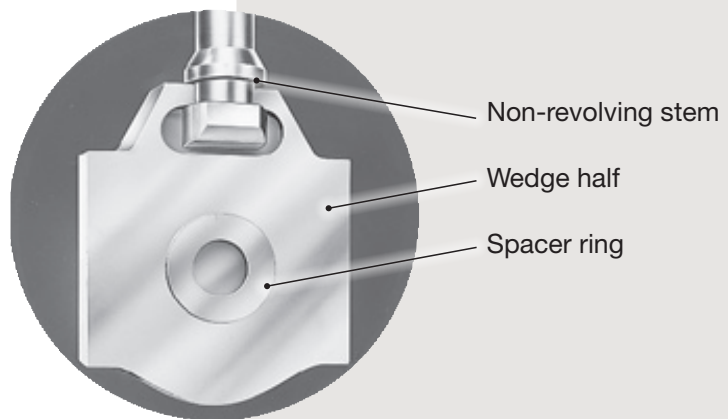



# Features and benefits

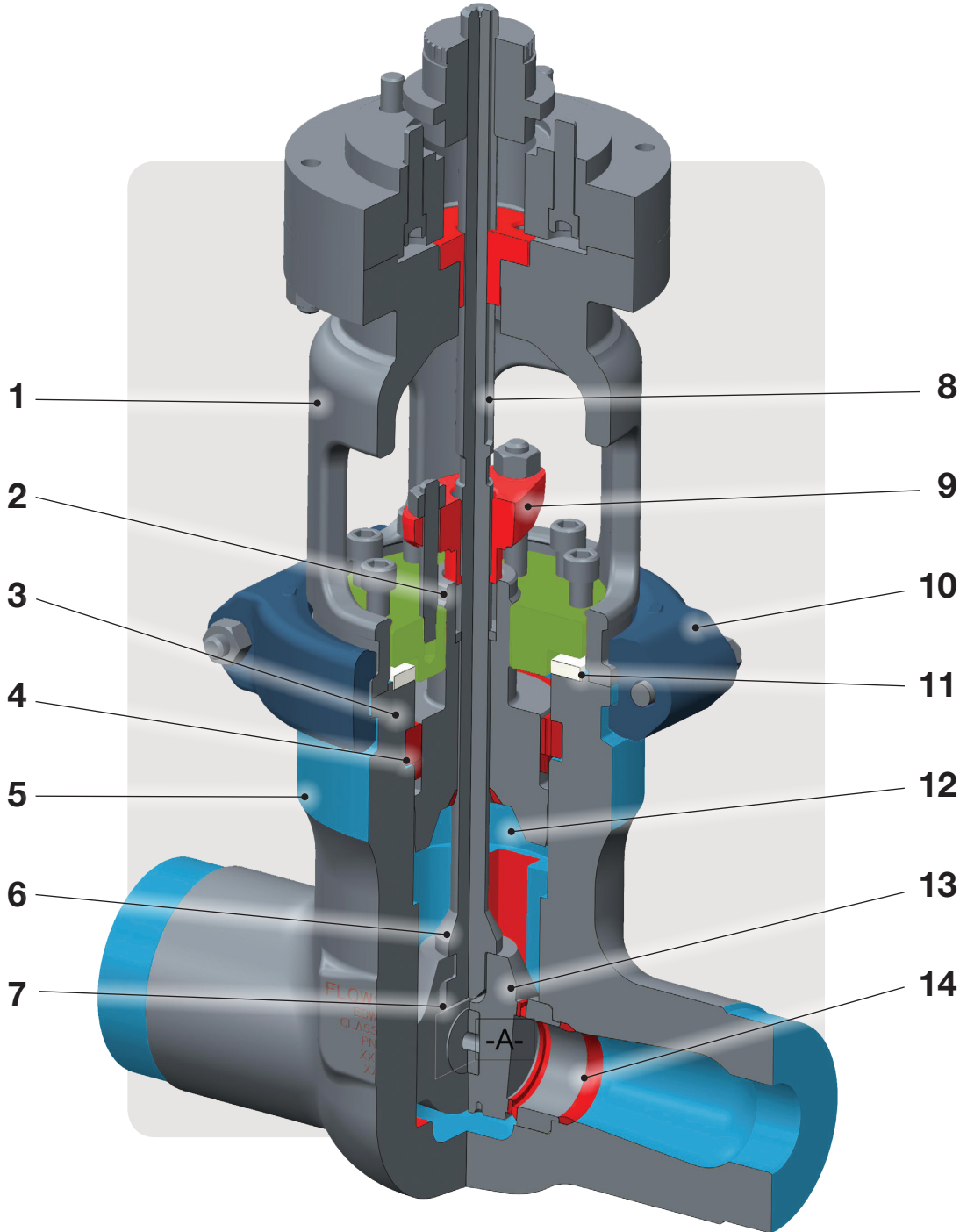

1. **Yoke** — the yoke is designed for ready access to the packing chamber.
2. **Packing and junk ring** — utilizes flexible graphite packing material with anti-extrusion rings for optimum sealability and life.
3. **Extended bonnet design** — further separates the packing chamber from fluid flow area for longer packing life.
4. **Composite pressure seal gasket** — preloaded, pressure-energized design, for long, reliable service.
5. **Body** — rugged single-piece forged steel body provides maximum flow efficiency. Information on alternate materials can be obtained through your Flowserve representative.
6. **Conical stem back seat** — Cone-on-cone design provides a reliable sealing geometry that operates over many valve cycles without leakage.
7. **Body guiding system** — holds the wedge halves together and absorbs thrust loads due to line flow. Integral hard-faced guide system components reduce friction and prevent galling for longer valve life.
8. **Stem** — has ACME threads, is machined to a fine finish, and is heat treated for improved strength and hardness to resist wear.
9. **Packing gland** — made of alloy steel and retained against the stuffing box pressure by an easy-to-maintain stud and heavy-hex nut assembly.
10. **Yoke lock ring** — permits easier field maintenance of upper structure without disturbing pressure-containing parts.
11. **Bonnet retaining ring** — assures an effective, tight seal by pulling the bonnet and gasket together at the pressure seal.
12. **Bonnet back seat** — especially hard-faced to assure long-term sealability.
13. **Two-piece wedge assembly** — allows each wedge half to flex and adjust independently to compensate for body distortions caused by thermal changes or pipe bending stresses.
14. **Welded-in seat ring with hard-faced seat** — assures better wear and longer valve life. Seat ring is welded into the valve body to prevent leakage.

# Dimensions and weights

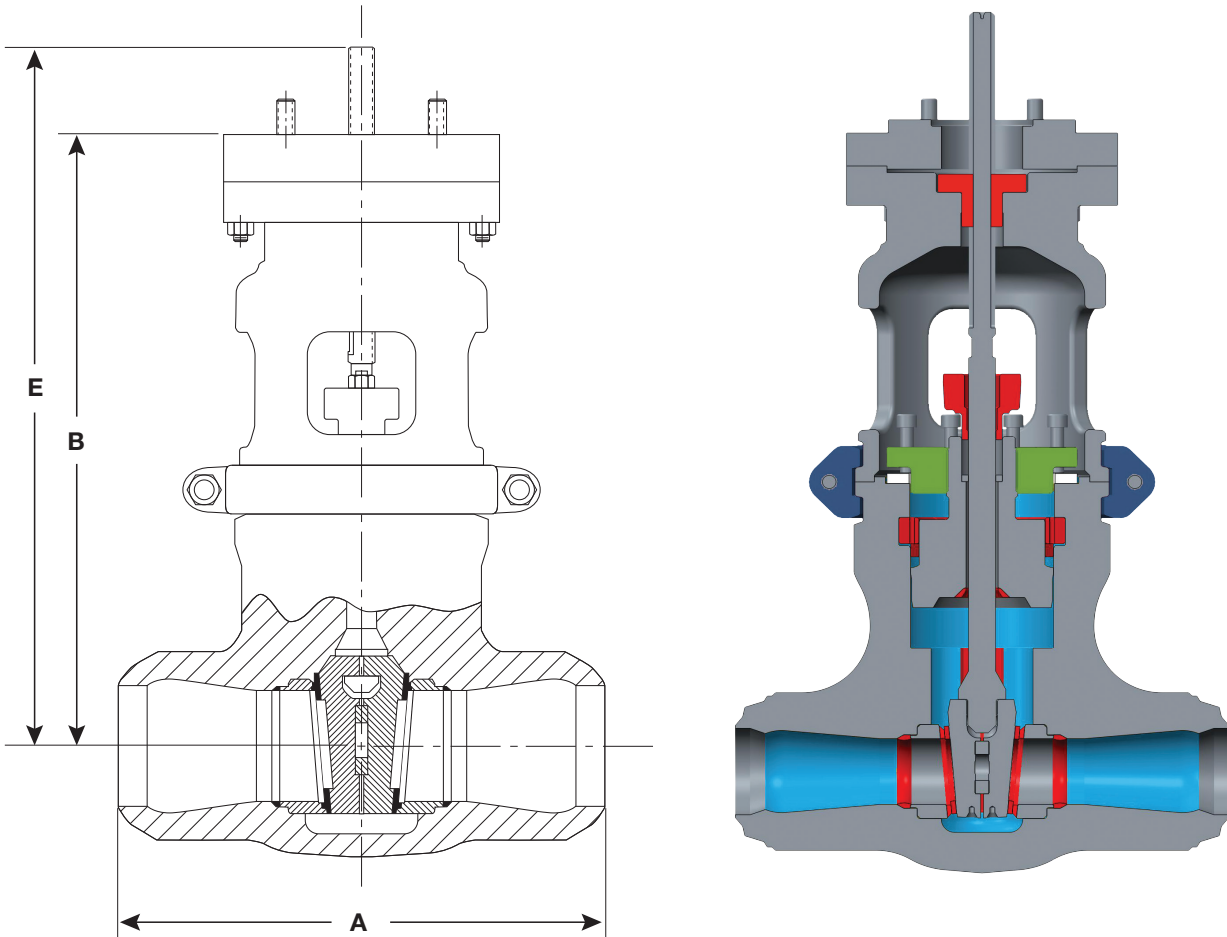

## Pressure class 1500 (B16.34), Series 2200 (EN 12516-2) – Regular and Venturi patterns

Fig No. 21511Y/32211Y

Dimension	Size, NPS (DIN)									
	4 (100)	6 (150)	8 (200)	10 (250)	12 (300)	14 (350)	16 (400)	18 (450)	20 (500)	22 (550)
A - End-to-end (welding**), in (mm)	*	*	*	*	*	*	47 (1194)	*	*	*
B - Center-to-actuator mounting, in (mm)	*	*	*	*	*	*	55.9 (1419)	*	*	*
E - Center-to-top of stem (open), in (mm)	*	*	*	*	*	*	77.1 (1959)	*	*	*
Weight (without actuator), lb (kg)	*	*	*	*	*	*	7685 (3500)	*	*	*

\* Consult Flowserve representative for figure numbers and applicable dimensions.

\*\* Buttweld ends



## Pressure class 2500 (B16.34), Series 3600 (EN 12516-2)—Regular and Venturi patterns

Fig No. 22511Y/33611Y

Dimension	Size, NPS (DIN)									
	4	6	8	10	12	14	16	18	20	22
	(100)	(150)	(200)	(250)	(300)	(350)	(400)	(450)	(500)	(550)
A - End-to-end (welding**), in (mm)	18 (457)	24 (610)	30 (762)	36 (914)	41 (1041)	44 (1118)	49 (1245)	49 (1245)	62 (1575)	64 (1626)
B - Center-to-actuator mounting, in (mm)	24.8 (629)	33.2 (843)	38.4 (974)	46.1 (1170)	50.5 (1283)	55 (1396)	63.3 (1608)	68.7 (1746)	*	80.5 (2045)
E - Center-to-top of stem (open), in (mm)	32.1 (815)	43.8 (1113)	51.2 (1300)	62.9 (1598)	71.5 (1815)	73.7 (1872)	84.0 (2134)	92.1 (2340)	*	108.9 (2765)
Weight (without actuator), lb (kg)	450 (225)	1245 (575)	2225 (1025)	3880 (1775)	5620 (2550)	7398 (3375)	11 560 (5244)	15 285 (6950)	*	27 615 (12 550)

\* Consult Flowserve representative for figure numbers and applicable dimensions.

\*\* Buttweld ends

## Series 2700 (EN 12516-2)—Regular and Venturi patterns

Fig No. 32711Y

Dimension	Size, NPS (DIN)									
	4	6	8	10	12	14	16	18	20	22
	(100)	(150)	(200)	(250)	(300)	(350)	(400)	(450)	(500)	(550)
A - End-to-end (welding**), in (mm)	*	*	*	*	*	*	47 (1194)	53 (1346)	58 (1473)	67 (1702)
B - Center-to-actuator mounting, in (mm)	*	*	*	*	*	*	54.8 (1392)	56.9 (1445)	65.2 (1656)	71.1 (1806)
E - Center-to-top of stem (open), in (mm)	*	*	*	*	*	*	74.2 (1885)	78.0 (1981)	87.7 (2228)	96.3 (2446)
Weight (without actuator), lb (kg)	*	*	*	*	*	*	4975 (2257)	7655 (3472)	10 960 (4971)	14 165 (6425)

\* Consult Flowserve representative for figure numbers and applicable dimensions.

\*\* Buttweld ends

## Flow coefficients

### Pressure class 1500 (PN 260)

255.3 bar @ 38°C (3705 psi at 100°F)

Regular Port Configuration							
Fig. No. 21511Y Stop Valves							
SIZE		C <sub>v</sub>	FL	XT	KI	d	
NPS	DN						
16	400	12 000	0.39	0.08	0.02	13	330

Venturi Port Configuration							
Fig. No. 21511BY Stop Valves							
SIZE		C <sub>v</sub>	FL	XT	KI	d	
NPS	DN						
18x16x18	450x400x450	11 000	0.37	0.08	0.02	14.62	371

### Pressure class 2500 (PN 420)

425.5 bar @ 38°C (6170 psi at 100°F)

Regular Port Configuration							
Fig. No. 22511Y, 24411Y Stop Valves							
SIZE		C <sub>v</sub>	FL	XT	KI	d	
NPS	DN						
4	100	340	0.59	0.19	0.04	2.87	72.9
6	150	910	0.61	0.19	0.05	4.37	111
8	200	1850	0.51	0.14	0.04	5.75	146
10	250	2950	0.48	0.12	0.03	7.25	184
12	300	4350	0.46	0.11	0.03	8.82	219
14	350	5150	0.47	0.12	0.03	9.5	241
16	400	7050	0.46	0.11	0.03	10.87	276
18	450	8950	0.46	0.11	0.03	12.25	311
20	500	11 500	0.45	0.11	0.03	13.5	343
22	550	14 000	0.45	0.11	0.03	14.87	378

Venturi Port Configuration							
Fig. No. 22511BY, 24411BY Stop Valves							
SIZE		C <sub>v</sub>	FL	XT	KI	d	
NPS	DN						
8x6x8	200x150x200	1000	0.44	0.12	0.04	5.75	146
10x8x10	250x200x250	1650	0.46	0.14	0.04	7.25	184
12x10x12	300x250x300	2750	0.43	0.11	0.03	8.62	219
14x12x14	350x300x350	3900	0.46	0.13	0.03	9.5	241
16x14x16	400x350x400	4850	0.44	0.12	0.03	10.87	276
18x16x18	450x400x450	6450	0.43	0.11	0.03	12.25	311
20x18x20	500x450x500	8200	0.44	0.12	0.03	13.5	343
22x20x22	550x500x550	11 500	0.39	0.1	0.03	14.87	378
24x20x24	600x500x600	10 500	0.39	0.1	0.03	16.25	413
26x22x26	650x550x650	13 000	0.39	0.09	0.02	17.62	448

## Series 2700 (EN 12516-2)

136.2 bar @ 38°C (1973 psi at 100°F)

Regular Port Configuration							
Fig. No. 32711Y Stop Valves							
SIZE		C <sub>v</sub>	FL	XT	KI	d	
NPS	DN						
16	400	7050	0.46	0.11	0.03	10.87	276
18	450	8950	0.46	0.11	0.03	12.25	311
20	500	11 500	0.45	0.11	0.03	13.5	343
22	550	14 000	0.45	0.11	0.03	14.87	378

Venturi Port Configuration							
Fig. No. 32711BY Stop Valves							
SIZE		C <sub>v</sub>	FL	XT	KI	d	
NPS	DN						
18x16x18	450x400x450	6450	0.43	0.11	0.03	12.25	311
20x18x20	500x450x500	8200	0.44	0.12	0.03	13.5	343
22x20x22	550x500x550	11 500	0.39	0.1	0.03	14.87	378
24x20x24	600x500x600	10 500	0.39	0.1	0.03	16.25	413
26x22x26	650x550x650	13 000	0.39	0.09	0.02	17.62	448



#### **Headquarters**

Flowserve Corporation  
5215 North O'Connor Blvd.  
Suite 2300  
Irving, Texas 75039-5421 USA  
Telephone: +1 937 890 5839

#### **USA**

Flowserve Corporation  
1900 South Saunders Street  
Raleigh, NC 27603  
Phone: +1 919 832 0525  
Fax: +1 919 831 3369

**EVENBR1010-02 (A4)** September 2018

Flowserve Corporation has established industry leadership in the design and manufacture of its products. When properly selected, this Flowserve product is designed to perform its intended function safely during its useful life. However, the purchaser or user of Flowserve products should be aware that Flowserve products might be used in numerous applications under a wide variety of industrial service conditions. Although Flowserve can provide general guidelines, it cannot provide specific data and warnings for all possible applications. The purchaser/user must therefore assume the ultimate responsibility for the proper sizing and selection, installation, operation, and maintenance of Flowserve products. The purchaser/user should read and understand the Installation Instructions included with the product, and train its employees and contractors in the safe use of Flowserve products in connection with the specific application.

While the information and specifications contained in this literature are believed to be accurate, they are supplied for informative purposes only and should not be considered certified or as a guarantee of satisfactory results by reliance thereon. Nothing contained herein is to be construed as a warranty or guarantee, express or implied, regarding any matter with respect to this product. Because Flowserve is continually improving and upgrading its product design, the specifications, dimensions and information contained herein are subject to change without notice. Should any question arise concerning these provisions, the purchaser/user should contact Flowserve Corporation at any one of its worldwide operations or offices.

©2018 Flowserve Corporation. All rights reserved. This document contains registered and unregistered trademarks of Flowserve Corporation. Other company, product, or service names may be trademarks or service marks of their respective companies.