



HSH Series

Balanced high-pressure pusher seal



Experience In Motion

HSH seals are built for extended reliability in high-pressure, high-speed and highly viscous services such as mainline crude oil pipeline pumps. HSH seals are balanced, flexible stator cartridge seals with drive mechanisms and seal face geometries engineered for high torque loads and long-term performance. The HSH seal is fully compliant with API 682 Type A requirements.

High performance meets broad capability

Typically, high-duty seals are custom designed to fit specific pieces of equipment and operating conditions. The HSH seal breaks this tradition by providing the widest standard operating range in terms of size, speed and pressure-handling capability of any Flowserve pump seal. All of this performance is included in a seal cartridge which fits in the standard seal chamber dimensions of API 610 pumps without requiring any equipment modifications.

When large, high-energy pumps are utilized in pipelines or inside petrochemical plants, refineries and power plants, the HSH seal can be deployed to handle the associated high torque loads, pressures and surface speeds.

From boiler feed water to crude oil and light hydrocarbons, the HSH seal is easily configured to cover the vast majority of moderate and high-duty services.

Available precision face topography waves enable the sealing of fluids with phase changes.

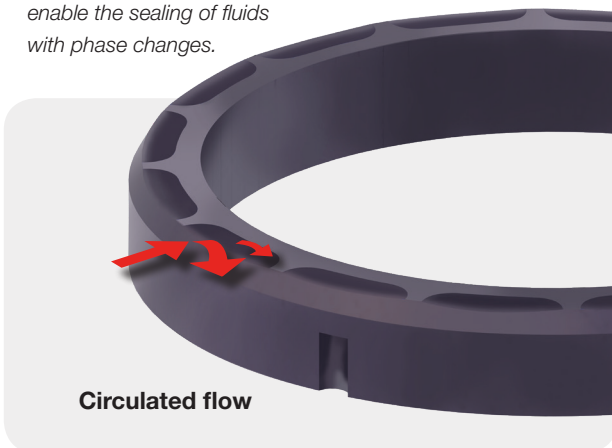

Applications

- Crude oil
- Bitumen
- Produced water
- Boiler feed water
- Liquefied natural gas, ethane and ethylene
- Amine
- Middle distillates
- Seawater
- Ammonia

Available high-pressure drives

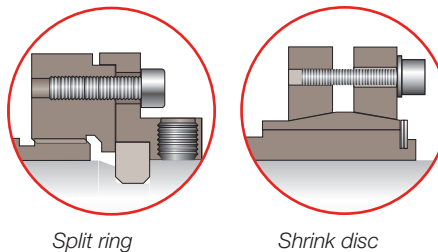

Available configurations

HSH

Arrangement 1 single seal
(common Piping Plans 11, 13, 23, 32, 62)

HSH/HSH

Arrangement 2 unpressurized dual-liquid buffer seal face-to-back configuration (common Piping Plans 52, 55)

HSH/GSL

Arrangement 2 unpressurized dual seal with dry running containment seal (common Piping Plans 72, 75, 76)

HSH/HSH

Arrangement 3 pressurized dual-liquid barrier seal face-to-face configuration (common Piping Plans 53A, 53B, 53C, 54)

Features and benefits

Multiport flush design improves heat dissipation for uniform face cooling

A standard distribution ring connected to the seal's flush port and located co-axially with the sealing interface improves the cooling efficiency of Piping Plans 11, 14, 21, 31 and 32 by injecting the flush flow 360 degrees around the seal faces.

Withstand high torque with heavy-duty, anti-rotation lugs engaged in seal face

High torque-capable, anti-rotation lugs along the length of the stationary seal face distribute contact loads, minimize distortion, and lower wear, especially for high viscosities.

Designed for high speeds and large shaft diameters

Flexible stator design with Alloy C-276 springs allows high-speed operation and is better able to tolerate out-of-square misalignment of the pump shaft to the seal chamber face.

Low drag rotating element minimizes turbulence around the seal faces and seal-generated heat from fluid shearing.

Designed for high pressures

Thick cross-section seal faces are designed with proven FEA techniques to minimize deflections and stresses for reliable, low-leakage operation.

A block-style rotating seal face is mounted squarely against a lapped support surface and driven by equally distributed pins to stabilize the effects of mechanical and thermal loads.

Part interchangeability between single and dual seal arrangements

Minimizes inventory requirements and maximizes design flexibility.

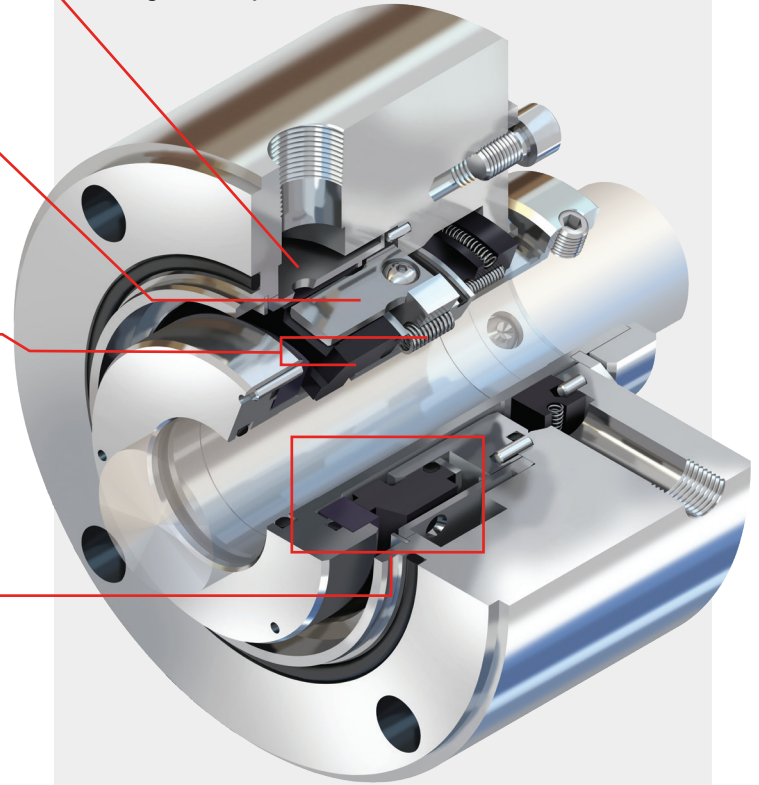

Single HSH seal model with floating segmented throttle bushing outboard

Reliability-enhancing features from the custom options library meet specific customer needs

HSH Series seals can be configured with a number of additional features, including:

- Flow-circulating devices
- Isolating seal chamber throat bushings
- Wear-resistant overlays for metal parts
- Secondary containment devices
- High-pressure sleeve drive collars
- Thermal isolation devices and cooling jackets

Materials of construction

Rotating face

Silicon carbide, tungsten carbide, diamond coating

Stationary face

Silicon carbide, carbon, diamond coating

Metal components

316 stainless steel, 17-4 PH stainless steel, Alloy C-276

Gaskets

Fluoroelastomer, perfluoroelastomer

Springs

Alloy C-276

Bushing

Carbon

Operating parameters

Dynamic pressure

to 103.4 bar (1500 psi)

Static pressure

to 206.8 (3000 psi)

Temperatures

-40°C to 260°C (-40°F to 500°F)

Specific gravity

0.3 and higher

Surface speed

to 46 m/s (150 fps)

Shaft sizes

25.4 to 156 mm
(1.000 to 6.125 in)

Available arrangements

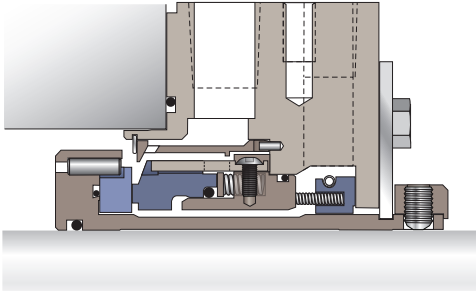

Arrangement 1 HSH single seal with floating balanced segmented throttle bushing for secondary containment

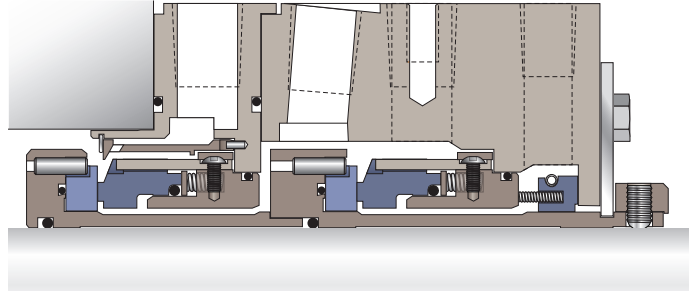

Arrangement 2 HSH/HSH unpressurized dual seal with liquid buffer fluid provides near-zero emissions sealing

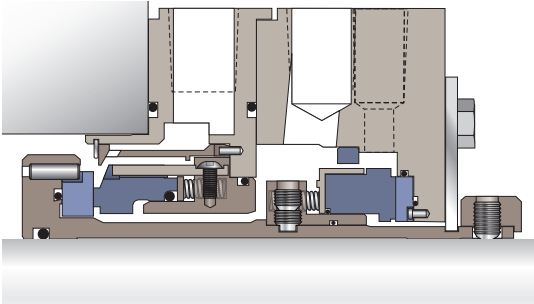

Arrangement 2 HSH/GSL unpressurized dual seal with gas buffer fluid provides near-zero emissions sealing

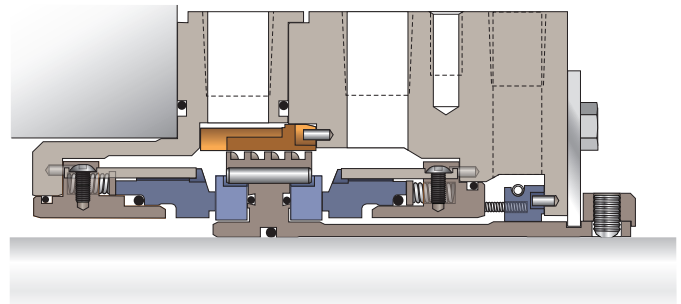

Arrangement 3 HSH/HSH face-to-face pressurized dual seal with barrier fluid provides zero-emissions sealing and reverse pressurization containment capability

Headquarters

Flowserve Corporation
5215 North O'Connor Blvd.
Suite 2300
Irving, Texas 75039-5421 USA
Telephone: +1 937 890 5839

USA and Canada

Kalamazoo, Michigan USA
Telephone: +1 269 381 2650

Europe, Middle East, Africa

Etten-Leur, The Netherlands
Telephone: +31 765 028 200

Asia Pacific

Singapore
Telephone: +65 6544 6800

Latin America

Mexico City
Telephone: +52 55 5567 7170

SSFLY000074 (EN/A4) October 2019

Flowserve Corporation has established industry leadership in the design and manufacture of its products. When properly selected, this Flowserve product is designed to perform its intended function safely during its useful life. However, the purchaser or user of Flowserve products should be aware that Flowserve products might be used in numerous applications under a wide variety of industrial service conditions. Although Flowserve can provide general guidelines, it cannot provide specific data and warnings for all possible applications. The purchaser/user must therefore assume the ultimate responsibility for the proper sizing and selection, installation, operation, and maintenance of Flowserve products. The purchaser/user should read and understand the Installation Instructions included with the product, and train its employees and contractors in the safe use of Flowserve products in connection with the specific application.

While the information and specifications contained in this literature are believed to be accurate, they are supplied for informative purposes only and should not be considered certified or as a guarantee of satisfactory results by reliance thereon. Nothing contained herein is to be construed as a warranty or guarantee, express or implied, regarding any matter with respect to this product. Because Flowserve is continually improving and upgrading its product design, the specifications, dimensions and information contained herein are subject to change without notice. Should any question arise concerning these provisions, the purchaser/user should contact Flowserve Corporation at any one of its worldwide operations or offices.

©2019 Flowserve Corporation. All rights reserved. This document contains registered and unregistered trademarks of Flowserve Corporation. Other company, product, or service names may be trademarks or service marks of their respective companies.